

**TECHNICAL MANUAL**

**AVIATION UNIT AND AVIATION  
INTERMEDIATE MAINTENANCE MANUAL**

**CH-47D HELICOPTER**

This manual together with TM 55-1520-240-23-1, TM 55-1520-240-23-2, TM 55-1520-240-23-3, TM 55-1520-240-23-4, TM 55-1520-240-23-5, TM 55-1520-240-23-6, TM 55-1520-240-23-7, TM 55-1520-240-23-8, TM 55-1520-240-23-9, TM 55-1520-240-23-11, supersedes TM 55-1520-240-23-1, TM 55-1520-240-23-2, TM 55-1520-240-23-3, TM 55-1520-240-23-4, TM 55-1520-240-23-5, TM 55-1520-240-23-7, TM 55-1520-240-23-8, TM 55-1520-240-23-9, TM 55-1520-240-23-10, 10 May 1983, and TM 55-1520-240-23-6, 6 May 1983, including all changes.

DISTRIBUTION STATEMENT A: Approved for public release; distribution is unlimited.



CHANGE  
NO. 1

HEADQUARTERS  
DEPARTMENT OF THE ARMY  
WASHINGTON, D.C., 30 SEPTEMBER 2003

Aviation Unit and Aviation Intermediate  
Maintenance Manual

**CH-47D HELICOPTER**

DISTRIBUTION STATEMENT A: Approved for public release; distribution is unlimited.

TM 55-1520-240-23-10, 19 September 2002, is changed as follows:

1. Remove and insert pages as indicated below. New or changed text material is indicated by a vertical bar in the margin. An illustration change is indicated by a miniature pointing hand.

**Remove pages**

A/(B blank)  
i and ii  
12-19 through 12-22  
12-25 through 12-30  
12-85 through 12-88  
12-93 through 12-96  
12-97 and 19-98  
12-99 and 12-100  
13-103 and 13-104  
16-95 and 16-96  
16-149 and 16-150  
-----  
-----  
-----

**Insert Pages**

A/(B blank)  
i and ii  
12-19 through 12-22  
12-25 through 12-30  
12-85 through 12-88  
12-93 through 12-96  
-----  
(12-99 blank)/12-100  
13-103 and 13-104  
16-95 and 16-96  
16-149 and 16-150  
16-250.1 through 16-250.9  
16-250.10 blank  
16-250.11 through 16-250.58

2. Retain this sheet in front of the manual for reference purposes.

TM 55-1520-240-23-10

C1

By Order of the Secretary of the Army:

Official:

**PETER J. SCHOOMAKER**  
General, United States Army  
Chief of Staff

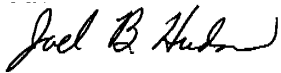

**JOEL B. HUDSON**  
Administrative Assistant to the  
Secretary of the Army  
0320903

DISTRIBUTION

To be distributed in accordance with Initial Distribution Number (IDN) 311199, requirements for TM 55-1520-240-23-10.

## WARNING AND FIRST AID DATA.

For artificial respiration and other first aid data, refer to FM 21-11.

Personnel performing instructions involving operations, procedures, and practices which are included or implied in this technical manual shall observe the following instructions. Disregard of these warnings and precautionary information can cause serious injury, illness, death, or an aborted mission.

### WARNING

An operating procedure, practice, etc., which if not correctly followed, could result in personal injury or loss of life.

### CAUTION

An operation procedure, practice, etc., which if not strictly observed, could result in damage to or destruction of equipment.

### NOTE

An operating procedure, condition, etc., which is essential to highlight.

### WARNING

## Cleaning Solvents

Those areas of skin and clothing that come in contact with cleaning solvents should be thoroughly washed immediately.

Saturated clothing should be removed immediately.

Areas in which cleaning solvents are used should be adequately ventilated to keep vapors to a minimum.

If cleaning solvents contact the eyes, nose, or ears, flush them with generous quantities of water, and then seek medical attention immediately.

### WARNING

## Electrical and Electronic Equipment Maintenance

Do not wear rings, watches, or metal jewelry when working around electrical equipment. Serious burns can result.

Be careful when working on 150- and 300-vdc circuits and on ac generator 115- and 200-vac outputs. Serious burns can result.

**WARNING**

### **Dangerous Static Charges**

Ground the helicopter during parking, fueling, or defueling. Sparks can cause fuel vapor to ignite.

**WARNING**

### **Dangerous Voltages at Antenna Terminals**

Be careful when working near antenna or antenna terminals. Radio frequency (rf) voltages exist at those points when transmitters are operating. Contact with radiating antennas can cause serious rf burns.

**WARNING**

### **Poisonous Carbon Monoxide Fumes**

Toxic carbon monoxide fumes may be present inside the helicopter whenever engines or APU are operating with cargo ramp open. Ventilate the cockpit.

**WARNING**

### **Corrosive Battery Electrolyte (Potassium Hydroxide)**

The electrolyte used in nickel-cadmium batteries contains potassium hydroxide which is a caustic substance.

Contact with skin or eyes will cause burns.

Use rubber gloves, rubber apron, and protective eye covering or face shield when handling battery.

If personal contact with electrolyte occurs, flush immediately with large amounts of only clean water. Get medical attention immediately.

**WARNING**

### **Explosive Battery Hazard**

Before removing or installing battery, make sure battery switch is OFF and battery has cooled down if overheated.

Connecting or disconnecting battery connector while battery is under load may cause explosion or electrical arcing resulting in injury to personnel.

**WARNING****Electrolyte Contamination**

Separate nickel cadmium batteries and lead-acid type batteries as far as possible from each other.

Do not let anything associated with a lead-acid battery, including air, come in contact with a nickel-cadmium battery or its electrolyte. Sulfuric acid fumes from a lead-acid battery could result in damage to a nickel-cadmium battery leading to battery failure and a hazard to personnel.

Do not use same tools or protective clothing for both types of batteries.

If sulfuric acid has been somehow mixed with electrolyte in the battery, the upper areas of the battery cells will appear green in color indicating battery failure or damage and potential danger to personnel unless replaced.

**WARNING****Acids and Alkalines**

Do not add water to acid. A violent action will result. Add acid to water in small quantities.

Rust stripper is an alkaline solution.

Avoid skin contact. Wear protective clothing. Wash thoroughly after using.

**WARNING****Windshield Rain Repellent**

Do not let windshield rain repellent contact open flame. Deadly hydrogen fluoride gas could be generated.

Wash hands with soap and water after handling repellent.

**WARNING****Antiseize Compounds**

Some antiseize compounds are irritants. Avoid inhaling fumes and contact with skin.

Wear protective clothing. Wash thoroughly after using.

**WARNING**

### **Paints, Varnishes, Dopes, Thinners, and Lubricants**

These materials are generally highly flammable and may be irritants. Work in a well-ventilated area away from open flames.

Avoid inhaling fumes and prolonged contact with skin. Wash thoroughly after using.

**WARNING**

### **Epoxy Resins, Cements, and Adhesives**

These materials may contain toxic or irritating substances. They may also be flammable. Work in a well-ventilated area away from open flames.

Wear protective clothing. Avoid contact with skin. Wash thoroughly after using.

**WARNING**

### **Radiation Hazard**

Some instruments contain radioactive material. Do not try to disassemble these instruments. They present no radiation hazard unless seal is broken.

If you think seal is broken, do not remove instrument from helicopter before consulting Base Radioactive Protection Officer (AR 40-15).

Use a beta-gamma radiac meter AN/PDR-27 or equivalent to determine if instrument contains radioactive material (radium).

**WARNING**

### **Fire Extinguishing Agents**

Monobromotrifluoromethane ( $\text{CF}_3\text{Br}$ ) is highly volatile but is not easily detected by smell. It is not toxic, but reduces oxygen available for proper breathing.

If liquid  $\text{CF}_3\text{Br}$  contacts skin, it can cause frostbite or low temperature burns.

If agent touches eyes or skin, immediately flush affected area with running water. Get medical attention.



**WARNING****Noise**

Sound pressure levels in this helicopter during some operating conditions exceed the Surgeon General's hearing conservation criteria (TB MED 251).

Hearing protection devices, such as aviator helmet or ear plugs, shall be worn by all personnel in and around the helicopter during operation.

**WARNING****FOD**

Make sure area is clear of foreign objects before closing access doors, panels, and fairings.

If area is not clear, damage to components or systems could result in personal injury or death.

**WARNING****JP-4/JP-5/JP-8 Fuel MIL-T-5624**

Fuel is flammable. Do not use near welding areas, open flames, or on very hot surfaces.

Use only with adequate ventilation.

Avoid prolonged or repeated contact with skin. Prolonged contact may cause drying and irritation of skin.

Remove saturated clothing immediately.

Do not smoke when handling fuel.

Do not take internally.

Store in approved, metal safety containers.

**WARNING****Lubricating Oils MIL-L-23699 or MIL-L-7808**

If oil is decomposed by heat, toxic gases are released.

Prolonged contact with liquid or mist may cause dermatitis and irritation.

If there is prolonged contact with skin, wash affected area with soap and water. If oil contacts eyes, flush with water immediately. Remove saturated clothing.

If swallowed, do not try to vomit. Seek immediate medical attention.

When handling liquid oil, wear rubber gloves. If prolonged contact with mist is likely, wear approved respirator.

**WARNING**

### **Lifting Components With Hoist**

Lifting or hoisting of components shall only be done by designated personnel.

The load capacity rating shall be clearly marked on hoist. Do not exceed load rating.

Inspection and testing for cracks or defects in hoist system shall be performed on a regular basis.

Before lifting, alert personnel in immediate areas.

Before lifting, balance the load.

Do not stand under load while it is being moved from one area to another on a hoist.

Do not stand under load to do maintenance work.

When positioning or stowing the cargo hook, do not grasp the hook assembly by the synchronizing assembly shaft. Serious injury can result. The strap handle is to be used when positioning or stowing the hook.

**WARNING**

### **Hydraulic Pressures**

High pressures used in testing hydraulic components can cause line rupture or component failure.

Only qualified personnel shall operate, service, and maintain hydraulic test equipment.

Use heavy plastic shielding at least 5/8-inch thick when applying pressures over 250 psi to prevent injury to personnel.

**WARNING**

### **Hydraulic Fluid**

Hydraulic fluid is toxic. It can irritate skin and eyes and cause burns. When fluid is decomposed by heating, it releases toxic gases.

Avoid inhaling. Use only with adequate ventilation. If prolonged contact with mist is likely, wear an appropriate respirator.

Avoid contact with skin, eyes, or clothing. Wear rubber gloves if handling liquid.

In case of contact with the skin, immediately wash skin with soap and water. In case of contact with eyes, flush them immediately with clear water and get medical attention.

If liquid is swallowed, do not induce vomiting. Get immediate medical attention.

**WARNING**

### **Compressed Air**

Do not use more than 30 psi compressed air for cleaning purposes. Debris propelled under pressure can cause injury to eyes.

Use eye protection to prevent injury to personnel.

**WARNING**

### **Flare Dispenser**

Flares can accidentally fire, sometimes from stray voltage. Injury or death can result.

Remove all electrical power from helicopter before installing loaded payload module on dispenser assembly.

Keep hands and face away from end of payload module during installation.

**WARNING**

### **Maintenance Platforms/Workstands**

Use only authorized maintenance platforms/workstands, or other approved locally procured stands and restraint equipment, when working above 10 feet on helicopters in a nontactical environment. Otherwise, personnel injury could result from accidental falls.

**WARNING**

### **Black Light Inspection Eyewear**

Do not wear eyeglasses having light sensitive lenses while performing magnetic particle (black light) or fluorescent penetrant inspections.

Such lenses have a 16 to 45 percent light transmission loss.

Wearing them can result in failure to detect flaws and cracks under ultraviolet light.

**WARNING**

### **Cadmium-Plated Tools**

Use only chrome-plated or unplated steel tools when working on the helicopter.

Cadmium or zinc-plated tools are not permitted, since these platings are prone to chipping and flaking. The chips and flakes could cause corrosion or fluid contamination.

All tools, regardless of plating type, shall be serviceable and free of chipping.



## LIST OF EFFECTIVE PAGES

Insert latest changed pages; dispose of superseded pages in accordance with regulations.

NOTE: On a changed page, the portion of the text affected by the latest change is indicated by a vertical line, or other change symbol, in the outer margin of the page. Changes to illustrations are indicated by miniature pointing hands. Changes to wiring diagrams are indicated by shaded areas.

Dates of issue for original and changed pages are:

Original	19 September 2002
Change 1	30 September 2003

Page No.	*Change No.	Page No.	*Change No.
Title .....	0	13-8 blank .....	0
a through g .....	0	13-9 – 13-102 .....	0
h blank .....	0	13-103 and 13-104 .....	1
A .....	1	13-105 – 13-183 .....	0
B blank .....	1	13-184 blank .....	0
i .....	1	14-1 – 14-58 .....	0
ii .....	0	15-1 – 15-3 .....	0
12-1 – 12-3 .....	0	15-4 blank .....	0
12-4 blank .....	0	15-5 – 15-42 .....	0
12-5 – 12-19 .....	0	16-1 – 16-7 .....	0
12-20 .....	1	16-8 blank .....	0
12-21 .....	0	16-9 – 16-94 .....	0
12-22 .....	1	16-95 .....	1
12-23 and 12-24 .....	0	16-96 – 16-149 .....	0
12-24 blank .....	0	16-150 .....	1
12-25 .....	0	16-151 – 16-223 .....	0
12-26 .....	1	16-224 blank .....	0
12-27 .....	0	16-225 – 16-249 .....	0
12-28 and 12-29 .....	1	16-250 blank .....	0
12-30 – 12-79 .....	0	16-250.1 – 16-250.9 .....	1
12-80 blank .....	0	16-250.10 blank added ..	1
12-81 – 12-84 .....	0	16-250.11 – 16-250.58 ...	1
12-85 – 12-88 .....	1	16-251 – 16-261 .....	0
12-89 – 12-92 .....	0	16-262 blank .....	0
12-93 – 12-96 .....	1	16-263 – 16-331 .....	0
12-97 and 12-98 deleted .	1	16-332 blank .....	0
12-99 blank .....	1	16-333 – 16-351 .....	0
12-100 .....	1	16-352 blank .....	0
12-101 – 12-111 .....	0	16-353 – 16-386 .....	0
12-112 blank .....	0		
13-1 – 13-7 .....	0		

\*Zero in this column indicates an original page.



**AVIATION UNIT AND AVIATION  
INTERMEDIATE MAINTENANCE MANUAL  
CH-47D HELICOPTER**

**REPORTING ERRORS AND RECOMMENDING IMPROVEMENTS**

You can improve this manual. If you find any mistakes or if you know of a way to improve these procedures, please let us know. Mail your letter or DA Form 2028 (Recommended Changes to Publications and Blank Forms) located in the back of this manual, directly to: Commander, U.S. Army Aviation and Missile Command, ATTN: AMSAM-MMC-MA-NP, Redstone Arsenal, AL 35898-5000. A reply will be furnished to you. You may also provide DA Form 2028 information to AMCOM via e-mail, fax, or the World Wide Web. Our fax number is: DSN 788-6546 or Commercial 256-842-6546. Our e-mail address is: 2028@redstone.army.mil. Instructions for sending an electronic 2028 may be found at the back of this manual immediately preceding the hard copy 2028. For the World Wide Web use: <https://amcom2028.redstone.army.mil>.

**DISTRIBUTION STATEMENT A: Approved for public release; distribution is unlimited.**

**TABLE OF CONTENTS**

		PAGE NO.
<b>VOLUME</b>	<b>X</b>	
CHAPTER	12 UTILITY SYSTEMS .....	12-1
Section	I Windshield and Anti-Icing System Description and Theory of Operation .....	12-1
Section	II Windshield Anti-Icing System .....	12-5
Section	III Fire Detection and Extinguishing Systems Description and Theory of Operation .....	12-19
Section	IV Fire Detection and Extinguishing Systems .....	12-25
Section	V Windshield Wiper System Description and Operation .....	12-81
Section	VI Windshield Wiper System .....	12-83
CHAPTER	13 ENVIRONMENTAL CONTROLS .....	13-1
Section	I Environmental System Description and Theory of Operation .....	13-1
Section	II Environmental System .....	13-9
CHAPTER	14 HOISTS AND WINCHES .....	14-1
Section	I Cargo Handling System Description and Theory of Operation .....	14-1
Section	II Cargo Handling System .....	14-7
CHAPTER	15 AUXILIARY POWER UNIT .....	15-1
Section	I Auxiliary Power Unit Description and Sequence of Operation .....	15-1
Section	II Auxiliary Power Unit .....	15-5
CHAPTER	16 MISSION EQUIPMENT .....	16-1
Section	I Cargo Carrying Hook System Description and Theory of Operation .....	16-1
Section	II Cargo Carrying Hook System .....	16-9
Section	III Paratroop and Cargo Drop Equipment Description and Operation ..	16-211

\*This manual together with TM 55-1520-240-23-1, TM 55-1520-240-23-2, TM 55-1520-240-23-3, TM 55-1520-240-23-4, TM 55-1520-240-23-5, TM 55-1520-240-23-6, TM 55-1520-240-23-7, TM 55-1520-240-23-8, TM 55-1520-240-23-9, TM 55-1520-240-23-11, supersedes TM 55-1520-240-23-1, TM 55-1520-240-23-2, TM 55-1520-240-23-3, TM 55-1520-240-23-4, TM 55-1520-240-23-5, TM 55-1520-240-23-7, TM 55-1520-240-23-8, TM 55-1520-240-23-9, TM 55-1520-240-23-10, 10 May 1983, and TM 55-1520-240-23-6, 6 May 1983, including all changes.

			PAGE NO.
Section	IV	Paratroop and Cargo Drop Equipment . . . . .	16-213
Section	V	Flare Dispenser System Description and Theory of Operation . . . . .	16-225
Section	VI	Flare Dispenser System . . . . .	16-229
Section	VI.1	An/Ale-47 Countermeasures Dispenser System (CMDS) Description and Theory Of Operation . . . . .	16-250.1
Section	VI.2	An/Ale-47 Countermeasures Dispenser System (CMDS) . . . . .	16-250.11
Section	VII	Litter Provisions Description and Operation . . . . .	16-251
Section	VIII	Litter Provisions . . . . .	16-253
Section	IX	Seat Armor Provisions Descriptions . . . . .	16-263
Section	X	Seat Armor Provisions . . . . .	16-265
Section	XI	Ski Provisions Description . . . . .	16-305
Section	XII	Ski Provisions . . . . .	16-307
Section	XIII	Head Up Display Description and Operation . . . . .	16-329
Section	XIV	Head Up Display . . . . .	16-335
Section	XV	Extended Range Fuel System (ERFS II) Description and Operation . . . . .	16-347
Section	XVI	Extended Range Fuel System (ERFS II) . . . . .	16-349
Section	XVII	Engine Air Particle Separator System (EAPS) Provisions Description and Operation . . . . .	16-355
INDEX		See Volume XI	



# **CHAPTER 12**

# **UTILITY SYSTEMS**

## **SECTION I**

### **WINDSHIELD AND ANTI-ICING SYSTEM DESCRIPTION AND THEORY OF OPERATION**

**DESCRIPTION**

The windshield anti-icing system operates independently on the three cockpit windshields. The pilot's and copilot's windshields have anti-icing and anti-fogging systems. The center windshield has an anti-fogging system only.

The total system consists of the three windshields, three switches on the overhead panel, and three relays and control boxes behind the nose dynamic absorber. Each windshield is made of laminated layers with an embedded temperature sensor. The inner surface of the outside layer is a transparent heating element. When the switch is operated, current passes through the transparent element, heating the windshield.

Electrical circuits for the three windshields are identical, except that the cut-in temperature for the center windshield is lower.

**THEORY OF OPERATION**

When any of the windshield switches on the ANTI-ICE overhead panel is moved to ON, **28 vdc** is applied to the

temperature controller for the associated windshield. If the temperature of the windshield, as sensed by an imbedded sensor, is below **90°F (32°C)** (pilot's or copilot's windshield) or **80°F (27°C)** (center windshield), relay K1 in the controller is energized, applying **115 vac** to the heating element in the windshield.

As windshield temperature increases, resistance within the sensor also increases. When the temperature reaches **110°F (43°C)**, sensor resistance is high enough to reenergize the anti-ice power relay, cutting off power to the heating element. When the windshield cools, the sensor reenergizes the relay and current flows again to the heating element.

Power for the pilot's and center windshield comes from the No. 2 ac bus. Power for the copilot's windshield comes from the No. 1 ac bus. Temperature control of the pilot's and center windshield is through the No. 2 dc bus. Control of copilot's windshield temperature is through the No. 1 dc bus.

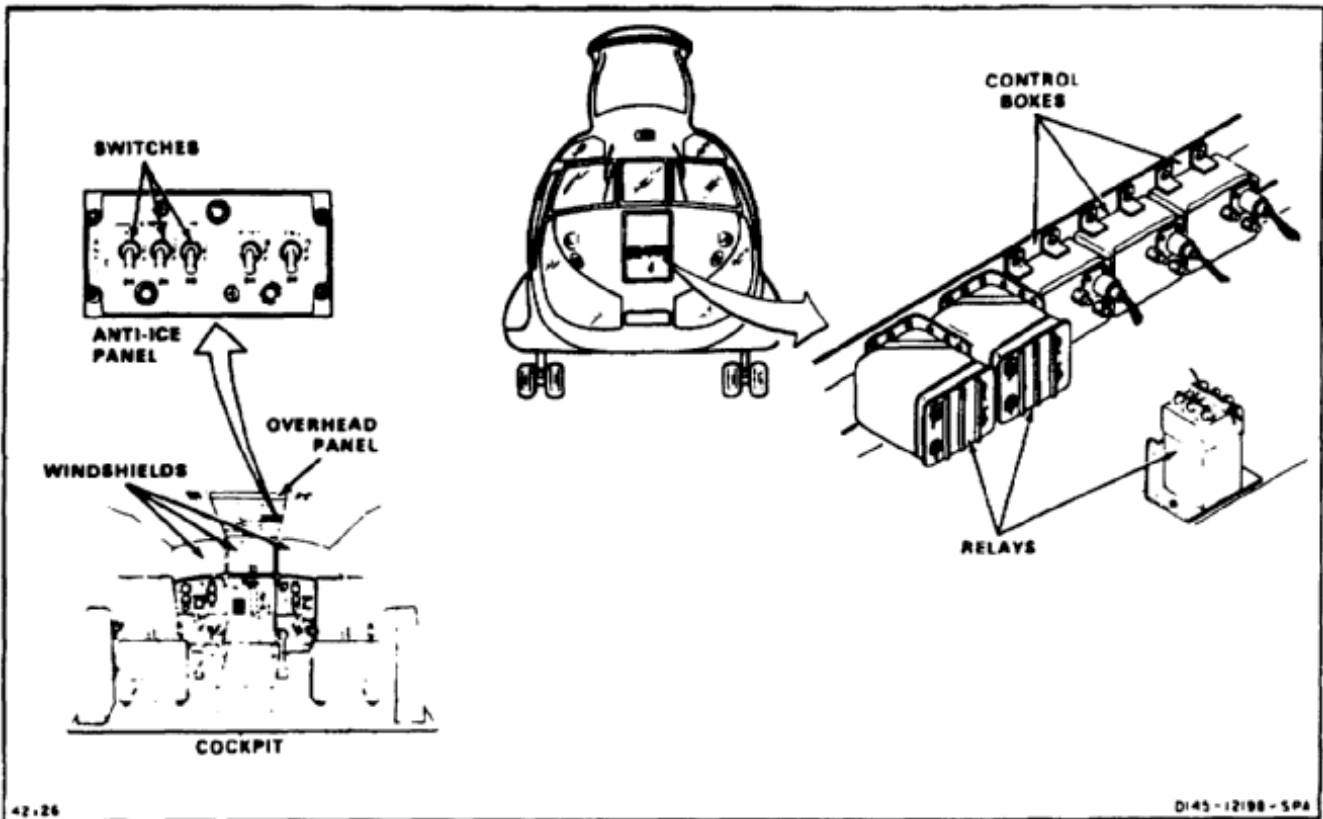

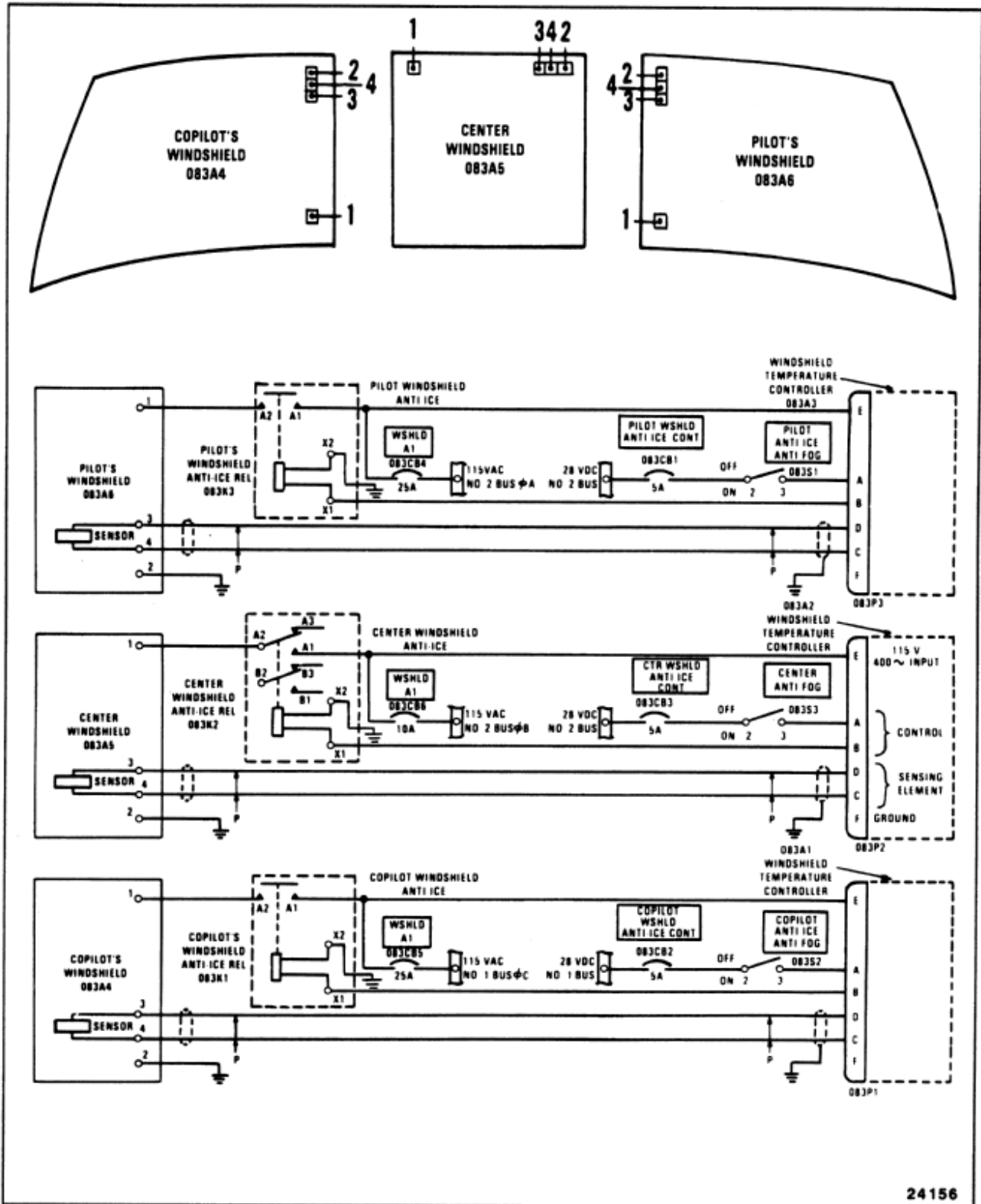

END OF TASK



**SECTION II**  
**WINDSHIELD ANTI-ICING SYSTEM**

INITIAL SETUP

**Applicable Configurations:**

All

**Tools:**

Electrical Repairer's Tool Kit, NSN 5180-00-323-4915  
Multimeter

**Materials:**

None

**Personnel Required:**

Aircraft Electrician

**References:**

TM 55-1520-240-23P

**Equipment Condition:**

Battery Disconnected (Task 1-39)  
Electrical Power Off  
Hydraulic Power Off

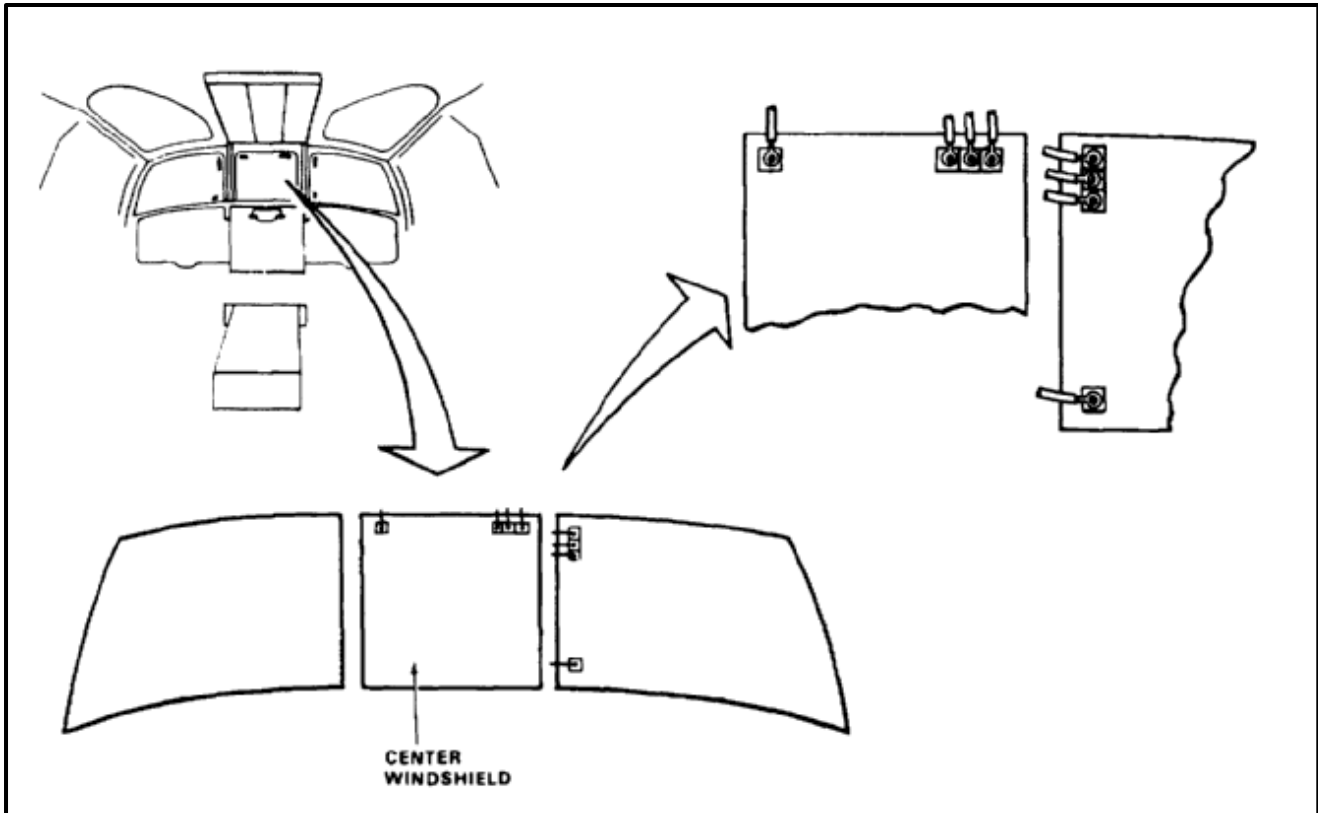

**PILOT'S OR COPILOT'S WINDSHIELD HEATING ELEMENT**

**NOTE**

Heating element cannot be seen. It is built into windshield.

Procedure is same to test pilot's or copilot's windshield, pilot's windshield is shown here.

1. Remove screw (1), lockwasher (2), and flat washer (3) from terminal (4). Disconnect wire (5).
2. Measure resistance between terminals (4 and 6). Resistance shall be as follows:

Part No.	Vendor	Resistance (ohms)
114SS601	All	5.6 to 7.6
114SS604	PPG	9.5 to 13.5
114SS604	Sierracin	6.0 to 9.0

Vendor identification is at upper edge of windshield.

3. Connect wire (5) to terminal (4). Install flat washer (3), lockwasher (2), and screw (1).

**CENTER WINDSHIELD HEATING ELEMENT**

4. Remove screw (1), lockwasher (2), and flat washer (3) from terminal (7). Disconnect wire (8).
5. Measure resistance between terminals (7 and 9). On windshields 114SS602 or 114SS604 series, resistance shall be **39.8 to 53.8 ohms**.
6. Connect wire (8) to terminal (7). Install flat washer (3), lockwasher (2), and screw (1).

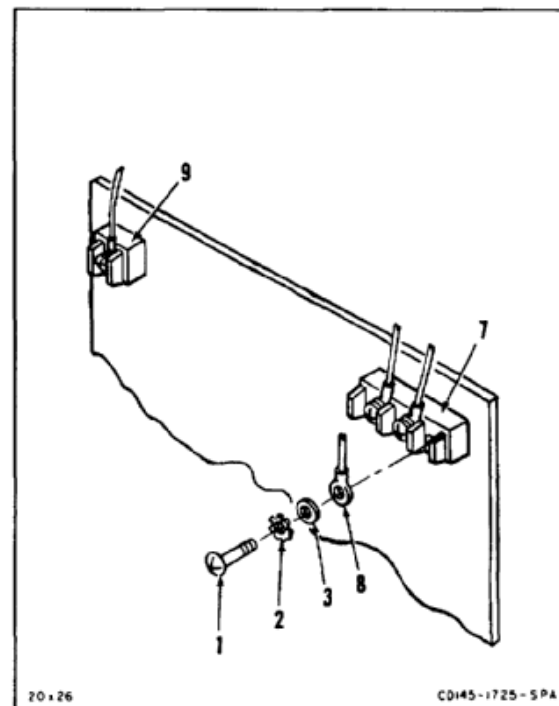
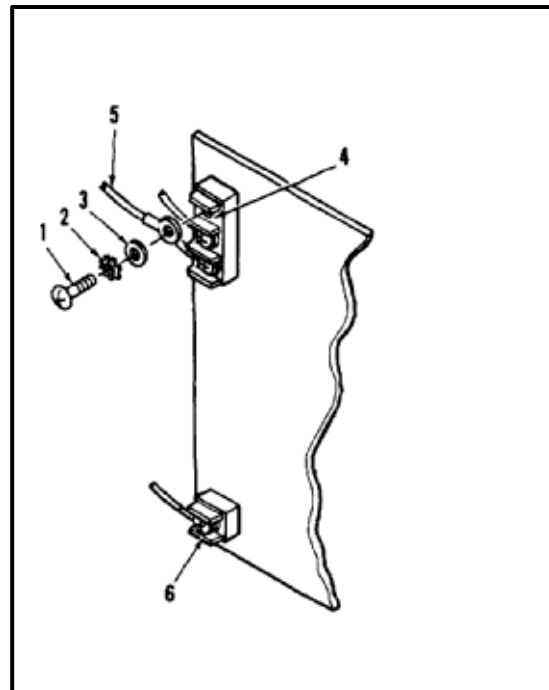

ZO 26

CDI45-1725-SPA

**PILOT'S OR COPILOT'S WINDSHIELD SENSING ELEMENT**

**NOTE**

Sensing element is embedded in windshield.

Windshield must not be in direct sun when reading temperature on FAT thermometer.

Procedure is same to test pilot's or copilot's windshield. Pilot's windshield is shown here.

7. Remove screw (1), lockwasher (2), and flat washer (3) from terminal (10). Disconnect wire (11).
8. Measure resistance between terminals (10 and 12). Resistance shall be as below for windshield temperature.

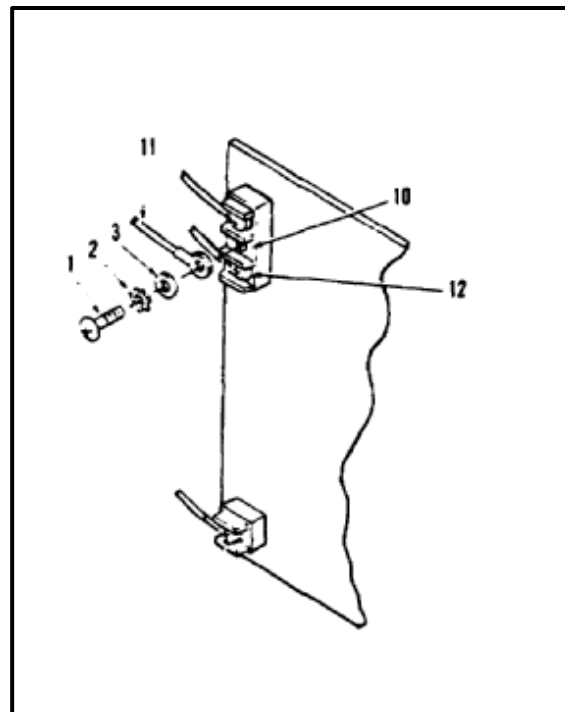

<b>If Temperature is:</b>	<b>Resistance Shall Be: (ohms)</b>
31° to 40°C (87° to 104°F)	318-340
21° to 30°C (69° to 86°F)	305-330
11° to 20°C (51° to 68°F)	289-321
1° to 10°C (33° to 50°F)	275-310
-9° to 0°C (15° to 32°F)	259-301
-19° to -10°C (-3° to 14°F)	245-290
-29° to -20°C (-21° to -4°F)	228-282

9. Connect wire (11) to terminal (10). Install flat washer (3), lockwasher (2), and screw (1).



**CENTER WINDSHIELD ANTI-FOGGING ELEMENT****NOTE**

Windshield must not be in direct sun when reading temperature on FAT thermometer.

10. Remove screw (1), lockwasher (2), and flat washer (3) from terminal (13). Disconnect wire (14).
11. Measure resistance between terminals (13 and 15). Resistance shall be as listed under step 8 for windshield temperature.
12. Connect wire (14) to terminal (13). Install flat washer (3), lockwasher (2), and screw (1).

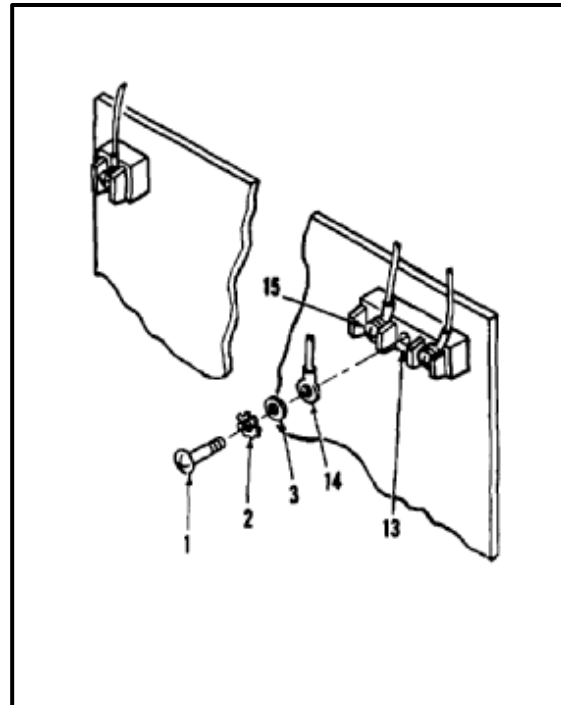
**FOLLOW-ON MAINTENANCE:**

None

END OF TASK

INITIAL SETUP

**Applicable Configurations:**

All

**Tools:**

Electrical Repairer's Tool Kit, NSN 5180-00-323-4915

**Materials:**

None

**Personnel Required:**

Aircraft Electrician

**Equipment Condition:**

Battery Disconnected (Task 1-39)

Electrical Power Off

Nose Dynamic Absorber Removed (Task 2-139)

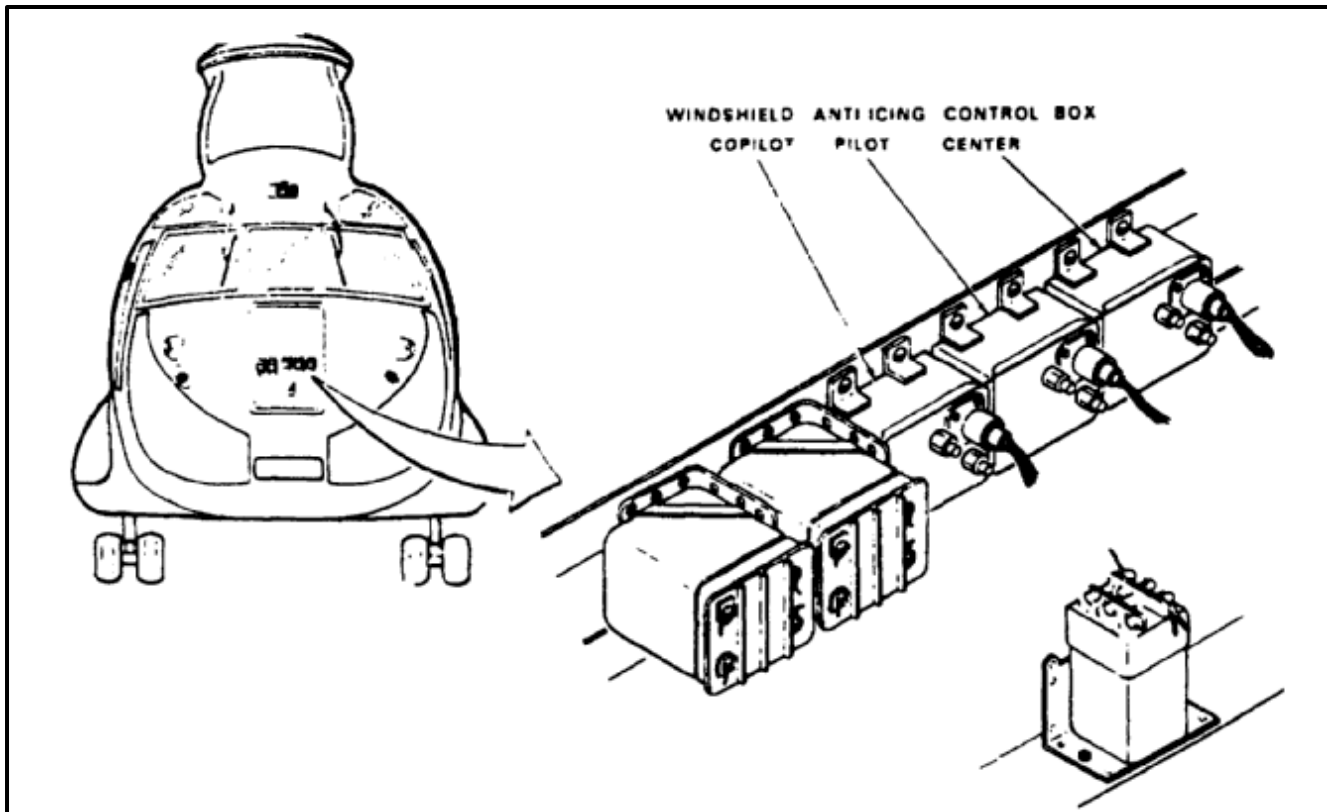

**NOTE**

Pilot, copilot, and center windshield anti-icing control boxes are in nose enclosure behind dynamic absorber. Removal procedure is same for all three. Center windshield anti-icing control box is shown here.

1. Disconnect electrical plug (1) from control box (2).

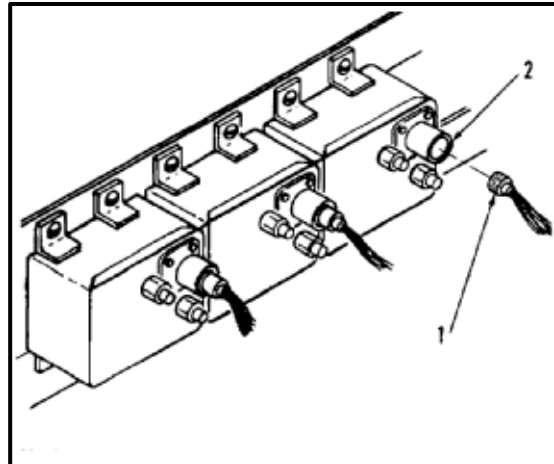

2. Remove four screws (3) and washers (4).

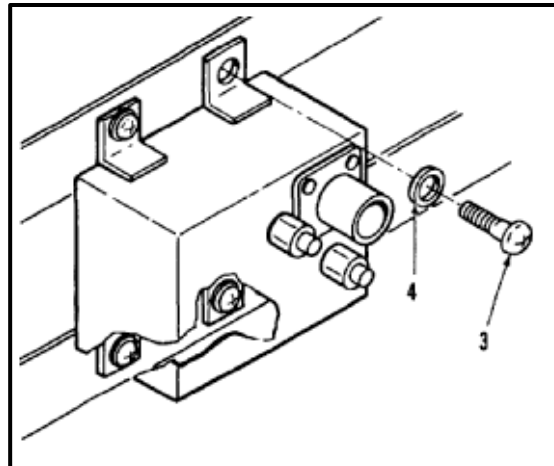

3. Remove control box (2).

**FOLLOW-ON MAINTENANCE:**

None

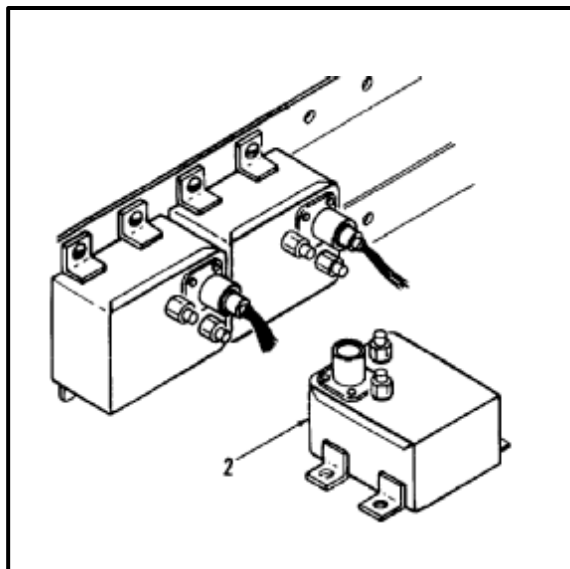

END OF TASK

INITIAL SETUP

**Applicable Configurations:**

All

**Tools:**

Electrical Repairer's Tool Kit, NSN 5180-00-323-4915

**Materials:**

None

**Personnel Required:**

Aircraft Electrician  
Inspector

**References:**

TM 55-1520-240-23P

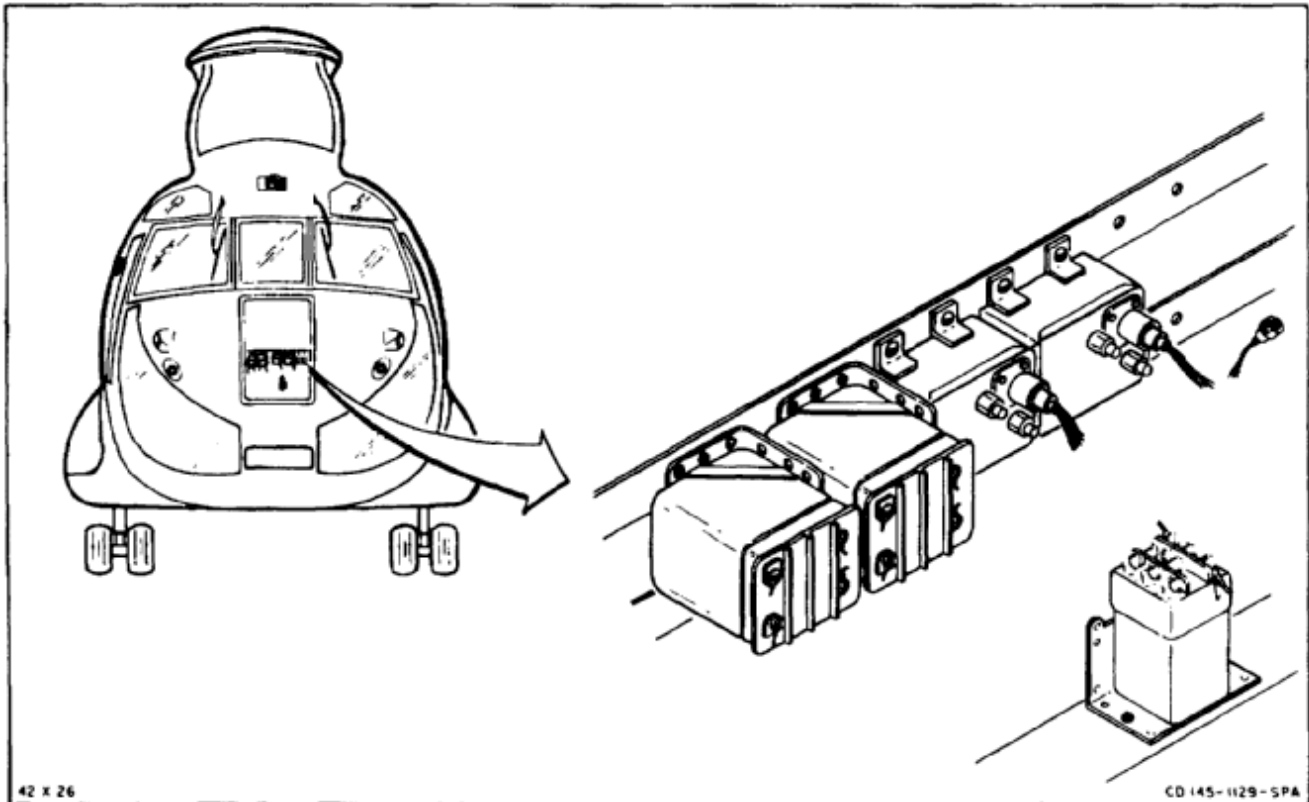

**NOTE**

Pilot, copilot, and center windshield anti-icing control boxes are in nose enclosure behind dynamic absorber. Installation procedure is same for all three. Center windshield anti-icing control box is shown here.

1. Position anti-icing control box (1) on structure (2) inside nose enclosure.
2. Install four screws (3) and washers (4).
3. Connect electrical plug (5) to control box (1).

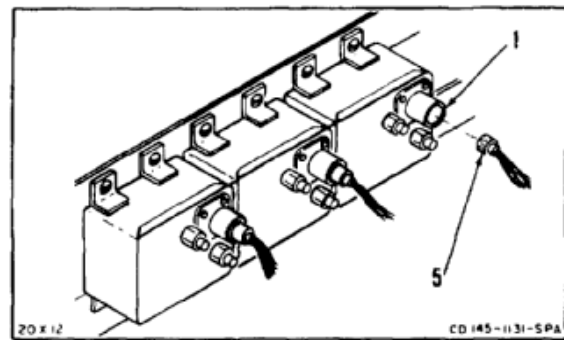
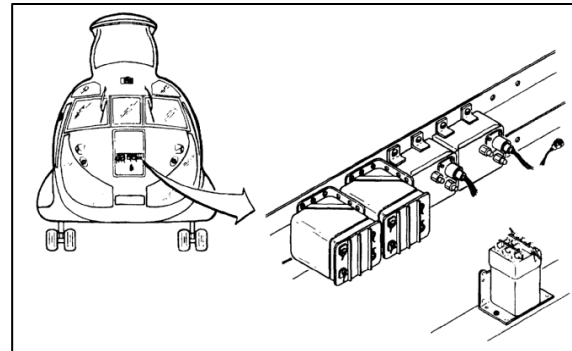
**INSPECT****FOLLOW-ON MAINTENANCE:**

Perform operational check (TM 55-1520-240-T).  
Install nose dynamic absorber (Task 2-143).

END OF TASK

INITIAL SETUP

**Applicable Configurations:**

All

**Tools:**

Electrical Repairer's Tool Kit, NSN 5180-00-323-4915

**Materials:**

Paper Tags (E264)

**Personnel Required:**

Aircraft Electrician

**Equipment Condition:**

Battery Disconnected (Task 1-39)

Electrical Power Off

Nose Dynamic Absorber Removed (Task 2-139)

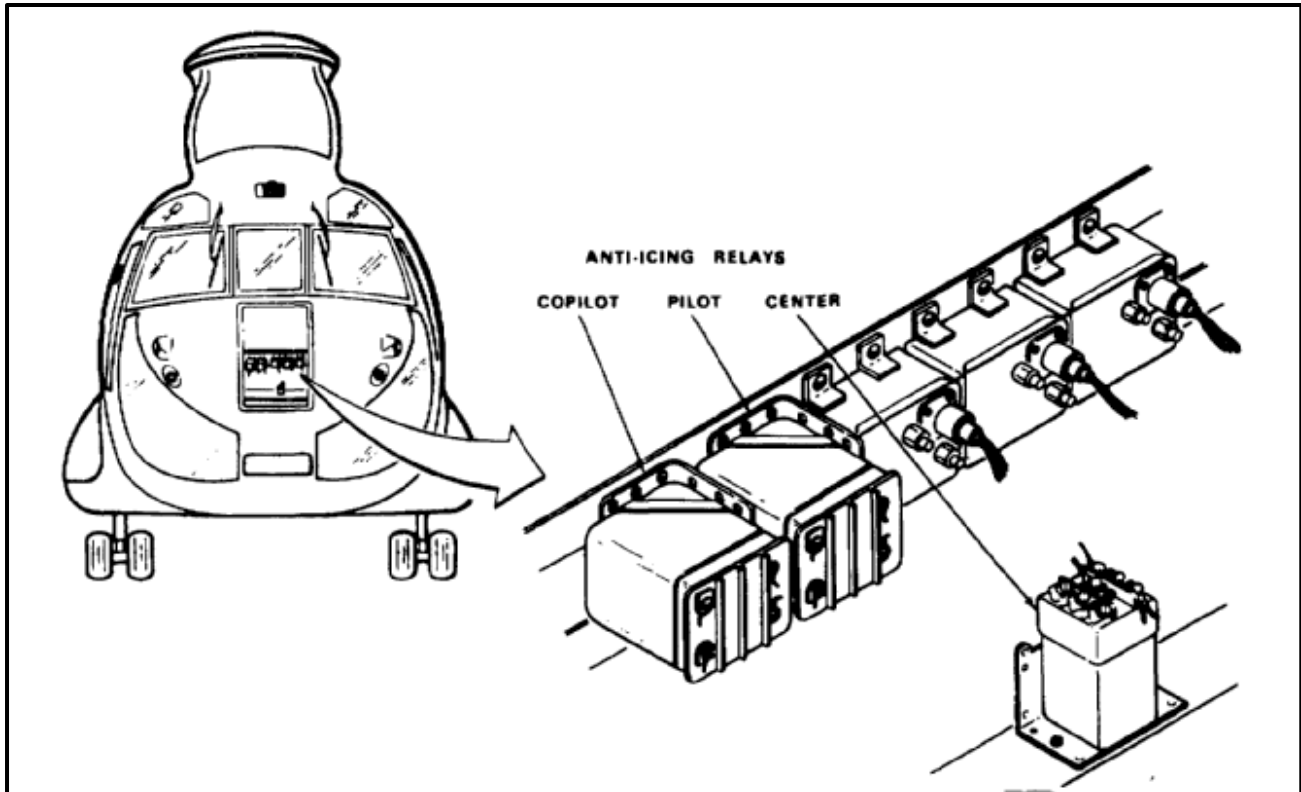

**NOTE**

Pilot and copilot anti-icing relays and center windshield anti-icing relay are removed differently. If removing pilot or copilot relay, perform steps 1 thru 3. If removing center windshield relay, perform steps 4 thru 6.

**PILOT AND COPILOT ANTI-ICING RELAYS****NOTE**

Pilot and copilot anti-icing relays are in nose enclosure, behind dynamic absorber. Removal procedure is same for both. Pilot anti-icing relay is shown here.

1. Tag and disconnect four wires (1) from relay (2) by removing four screws (3), lockwashers (4), and flat washers (5).
2. Remove four mounting screws (6) and washers (7).
3. Remove relay (2).

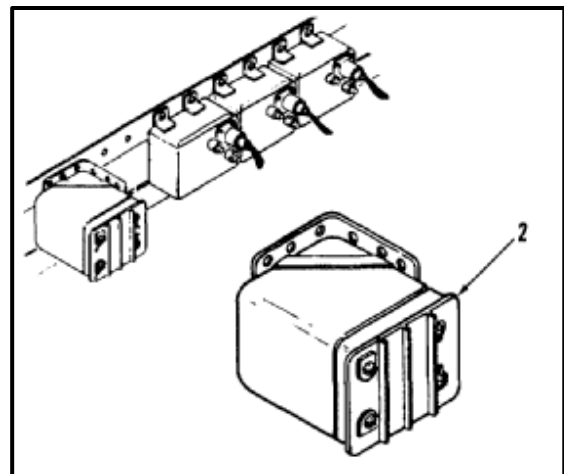
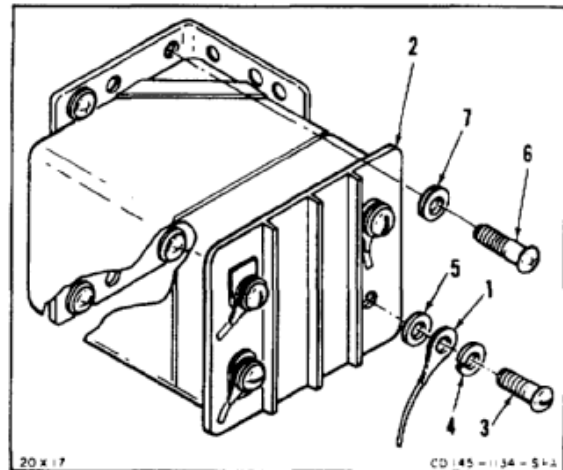

**CENTER WINDSHIELD ANTI-ICING RELAY****NOTE**

Center windshield anti-icing relay is in nose enclosure behind dynamic absorber.

4. Tag and disconnect five wires (8) from relay (9) by removing four screws (10) and washers (11).
5. Remove two screws (12) and washers (13).
6. Remove relay (9).

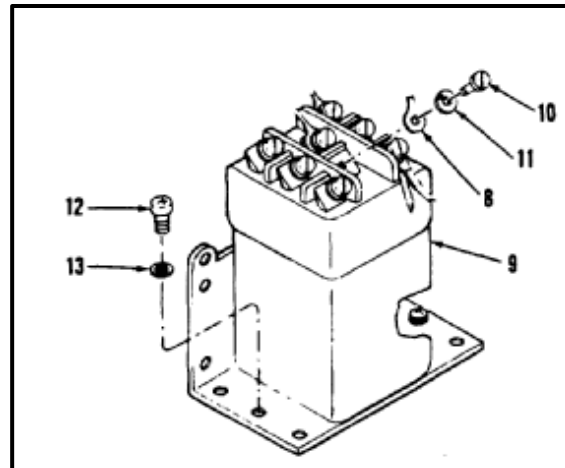
**FOLLOW-ON MAINTENANCE:**

None

END OF TASK



**12-6 INSTALL WINDSHIELD ANTI-ICING RELAYS**

12-6

**INITIAL SETUP****Applicable Configurations:**

All

**Tools:**

Electrical Repairer's Tool Kit, NSN 5180-00-323-4915

**Materials:**

None

**Personnel Required:**Aircraft Electrician  
Inspector**References:**

TM 55-1520-240-23P

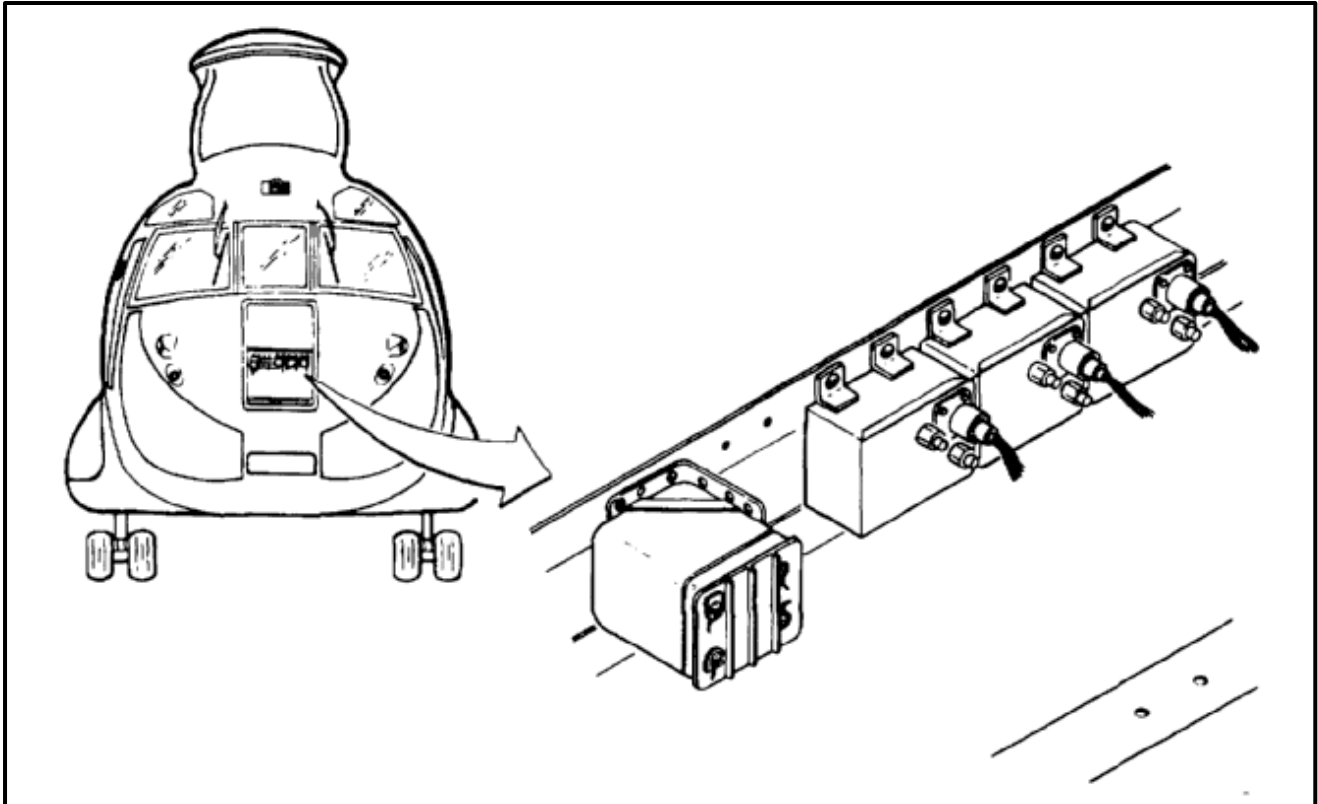

**NOTE**

Pilot and copilot anti-icing relays and center windshield anti-icing relay are installed differently. If installing pilot or copilot relay, perform steps 1 thru 3. If installing center windshield relay, perform steps 4 thru 6.

**PILOT AND COPILOT ANTI-ICING RELAYS****NOTE**

Pilot and copilot anti-icing relays are in nose enclosure, behind dynamic absorber. Installation procedure is same for both.

1. Position relay (1) on mounting structure (2) inside nose enclosure.
2. Install four screws (3) and washers (4).
3. Connect four electric wires (5) to relay (1) and install four flat washers (6), lockwashers (7), and screws (8). Remove tags from wires.

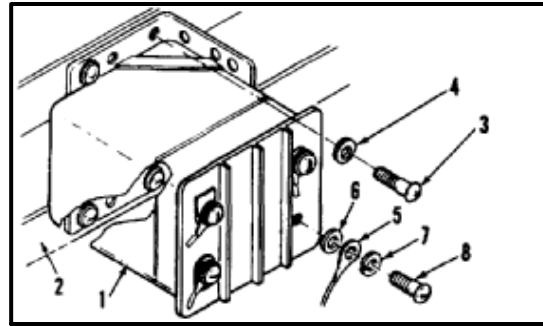
**CENTER WINDSHIELD ANTI-ICING RELAY****NOTE**

Center windshield anti-icing relay is in nose enclosure behind dynamic absorber.

4. Position relay (9) inside nose enclosure.
5. Install two screws (10) and washers (11).
6. Connect five wires (12) to relay (9) and install four washers (13) and screws (14). Remove tags from wires.

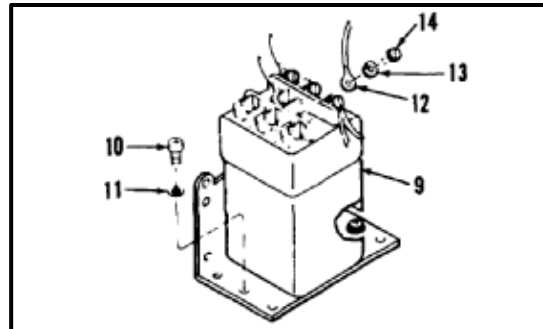
**INSPECT****FOLLOW-ON MAINTENANCE:**

Perform operational check (TM 55-1520-240-T).  
Install nose dynamic absorber (Task 2-143).

END OF TASK

**SECTION III**  
**FIRE DETECTION AND EXTINGUISHING SYSTEMS**  
**DESCRIPTION AND THEORY OF OPERATION**

**FIRE DETECTION SYSTEM DESCRIPTION**

The fire detection system consists of a fire detection loop routed around each engine, a control unit for each of the two loops, and a test switch and indicator lights in the cockpit.

Each fire detection loop consists of three sensing elements joined by connectors. Each element consists of a thin metallic tube with a wire running through the center, insulated from the tubing by a salt embedded in a ceramic matrix. The resistance of the insulating salt drops and the salt becomes conductive at about **575°F (300°C)**. The tubing is connected to ground. The central wire is connected to the control unit. The three elements have a combined length of about **19 feet**.

The two control units are mounted in the cabin at STA 482.00 left and right. Each unit contains an ac-powered magnetic amplifier and a dc test circuit. Each unit is connected to its respective fire detection loop. The units are sealed, and maintenance is limited to replacement.

A fire indicating light for each engine is located in the respective fire extinguisher handle on the cockpit center instrument panel. A test switch between the fire pull handles allows the light and electrical circuits to be checked.

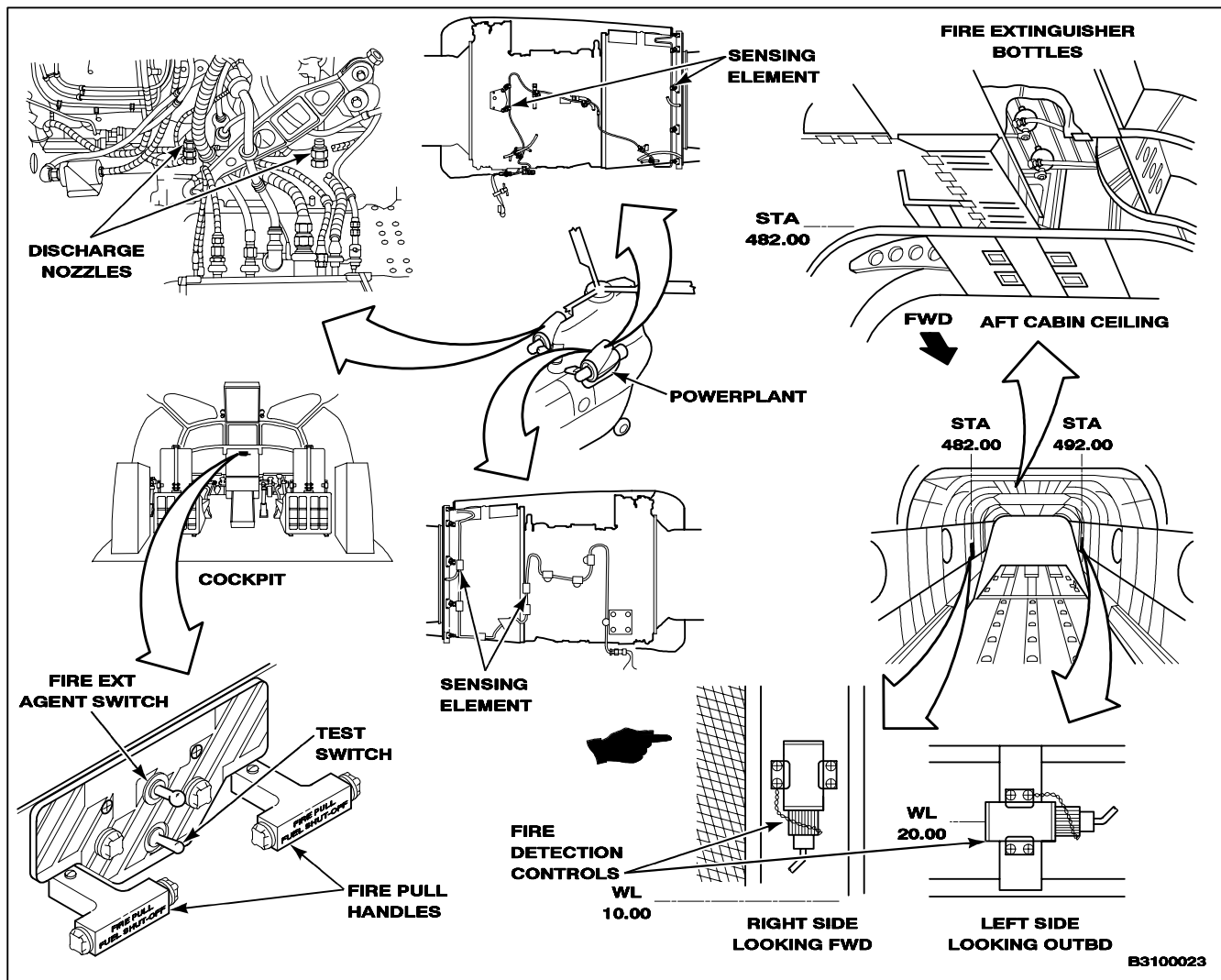

### THEORY OF OPERATION

Under normal conditions, the circuit within the magnetic amplifier of a control unit is in balance and no current flows to the warning lights. When the engine compartment temperature around the sensing element reaches about **575°F (300°C)**, indicating a fire, the insulating material between the sensing element tubing and the internal wire becomes conductive, allowing current to pass through the control unit to the appropriate warning light in the cockpit.

When the test switch on the center instrument panel is operated, **28 vdc** is delivered to the control units. Within each control unit, a relay operates to ground the system, lighting the warning lamps in the fire pull handles.

### FIRE EXTINGUISHING SYSTEM DESCRIPTION

Two containers filled with fire extinguishing agent are mounted in the base of the pylon, between the engines. In case of an engine fire, extinguishing agent within the containers can be discharged independently to the affected engine from the cockpit.

The system includes the two fire extinguishing agent containers, four discharge nozzles (one to each engine from each bottle), controls and switches in the cockpit, and associated tubing, wiring, and circuit breakers.

Each container is a metal sphere that holds a three-pound charge of non-toxic extinguishing agent. The agent is pre-charged with nitrogen at **600 psi** monitored by a gauge on the bottle. Separate lengths of tubing lead from the bottle to each engine, ending in a pair of discharge nozzles in each engine compartment. The two containers share the nozzles at each engine. The discharge paths are kept separate by a double check valve tee where the tubing from each container joins.

Discharge of extinguishing agent to the engines is controlled by two pull handles, one for each engine, and a toggle switch on the center instrument panel. Pulling a handle shuts off fuel to that engine and arms the circuit to the containers. Selecting one of the containers with the switch discharges extinguishing agent from that container to the affected engine. The remaining container may be discharged into the same or the opposite engine as required.

Electrical power for the system is supplied from the **28 vdc** No. 1 or No. 2 flight essential bus through circuit breakers in the No. 1 and No. 2 power distribution panels.

### THEORY OF OPERATION

When the fire detection system lights the warning lamps in either fire pull handle, the extinguishing system for the affected engine can be armed for operation by pulling out the lighted handle. When this is done, the following sequence of events occurs:

- a. Current from the **28 vdc** flight essential buses is directed by a switch through the engine fuel shutoff circuit breaker to close the engine fuel valve. This shuts off fuel to the affected engine.
- b. At the same time, the selector switch between the fire pull handles is armed. When the switch is operated to select a container, an explosive cartridge at that bottle is fired. This breaks a brittle retaining disc, releasing extinguishing agent from the bottle through the tubing to the two discharge nozzles at the affected engine.

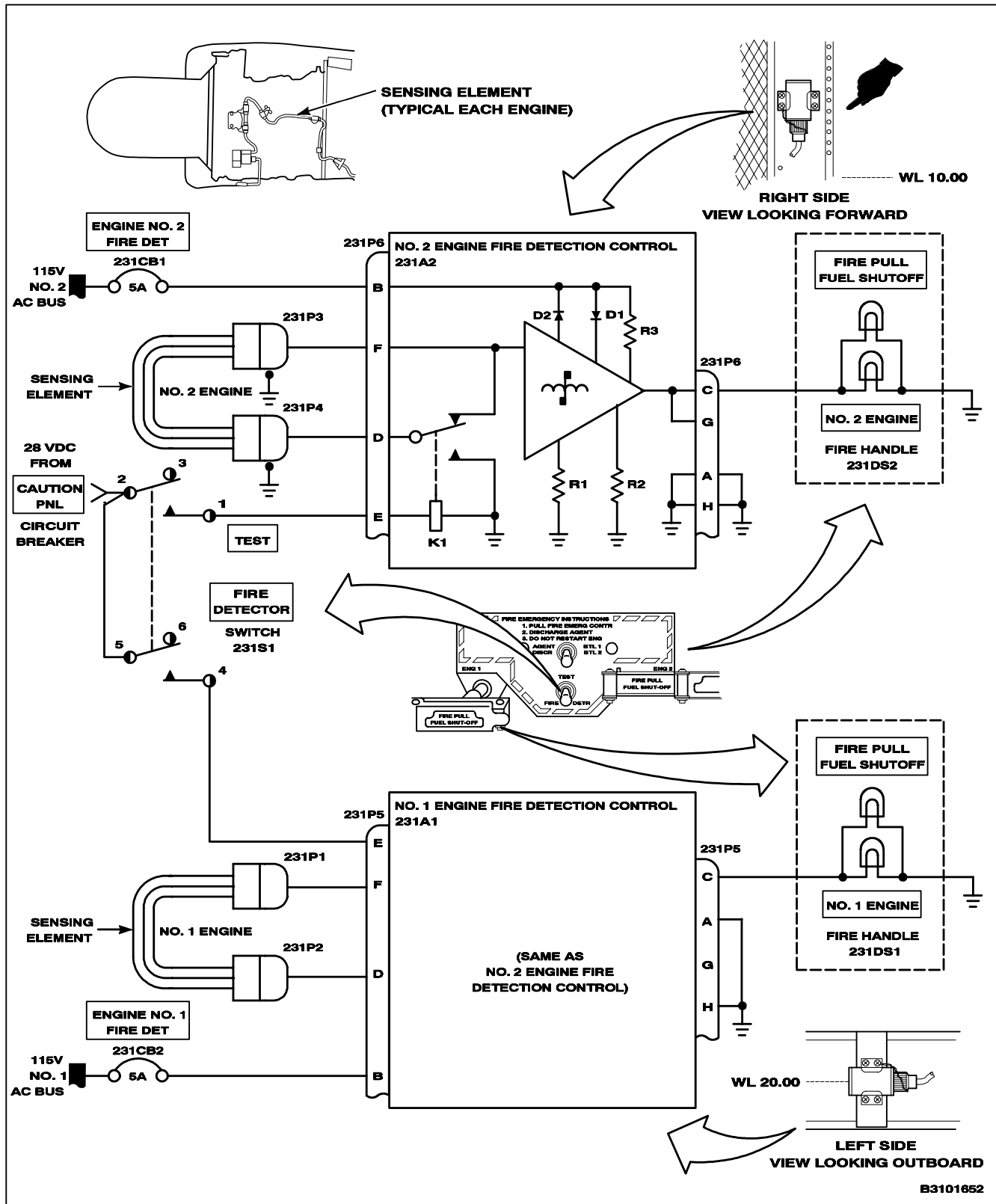

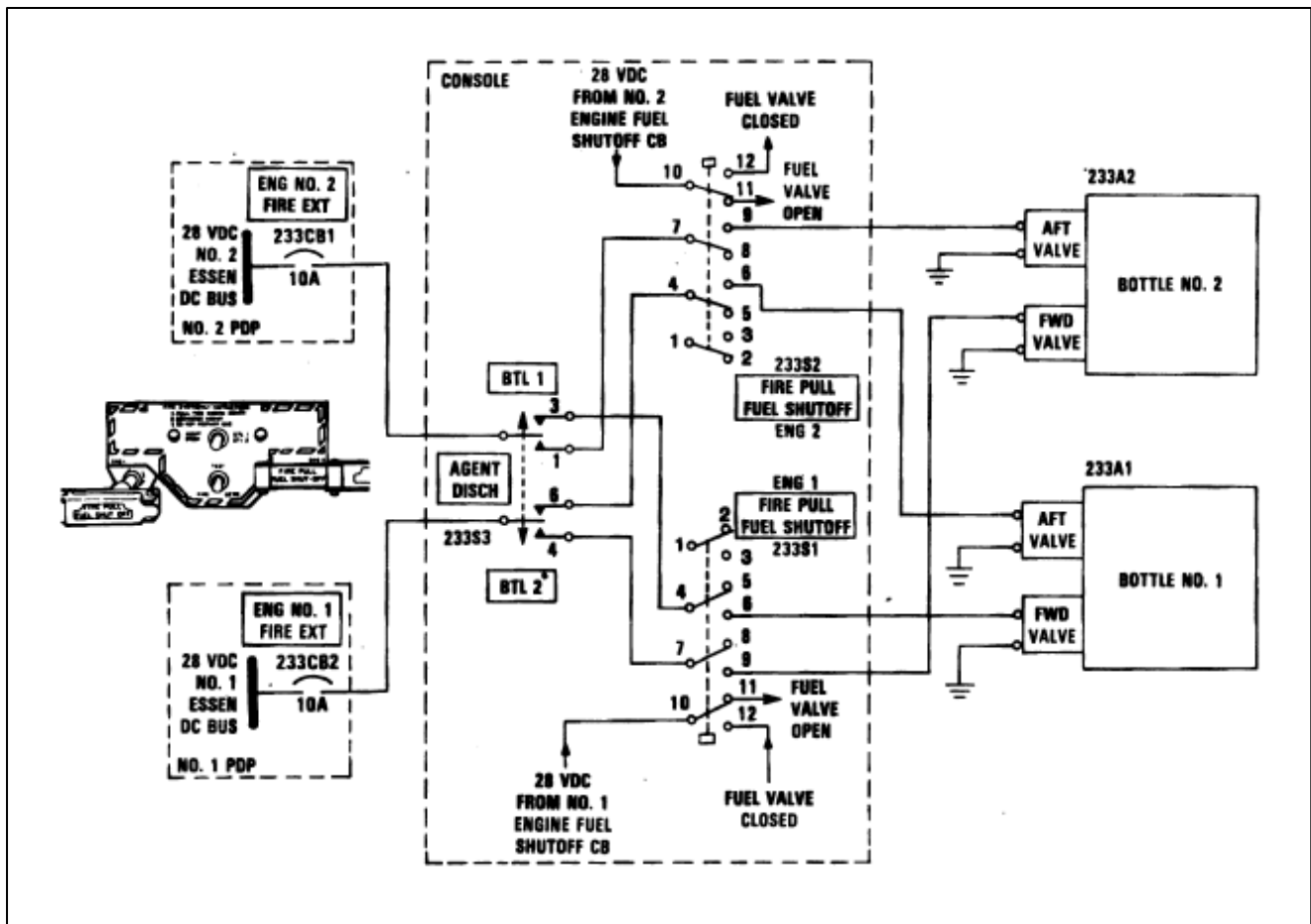

END OF TASK





**SECTION IV**  
**FIRE DETECTION AND EXTINGUISHING SYSTEMS**

INITIAL SETUP

**Applicable Configurations:**

All

**Tools:**

Electrical Repairer's Tool Kit, NSN 5180-00-323-4915

**Materials:**

None

**Personnel Required:**

Aircraft Electrician

**Equipment Condition:**

Battery Disconnected (Task 1-39)  
Electrical Power Off

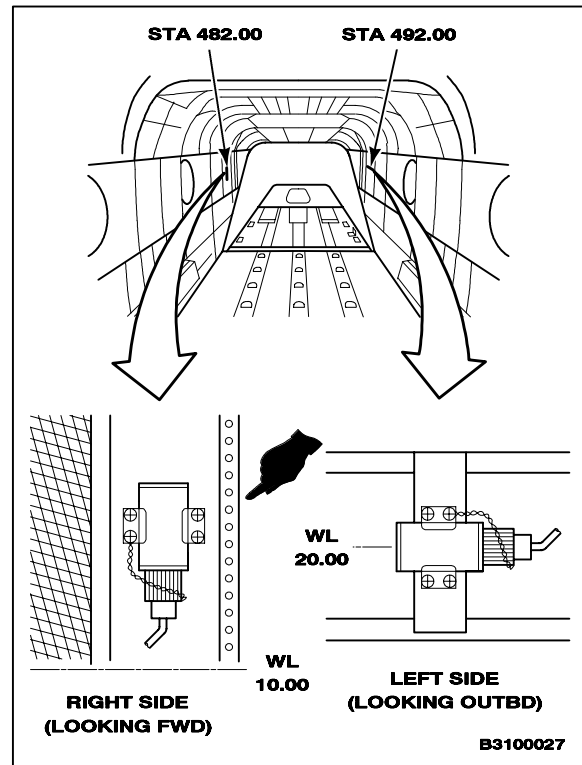

**NOTE**

If removing right side control, perform steps 1 thru 5. If removing left side control, perform steps 6 thru 9.

**RIGHT SIDE CONTROL**

1. Remove lockwire from plug (1) and screw (2).
2. Disconnect plug (1).
3. Pull back blanket (3).
4. Remove four nuts (4), screws (2), and five washers (5).
5. Remove control (6).

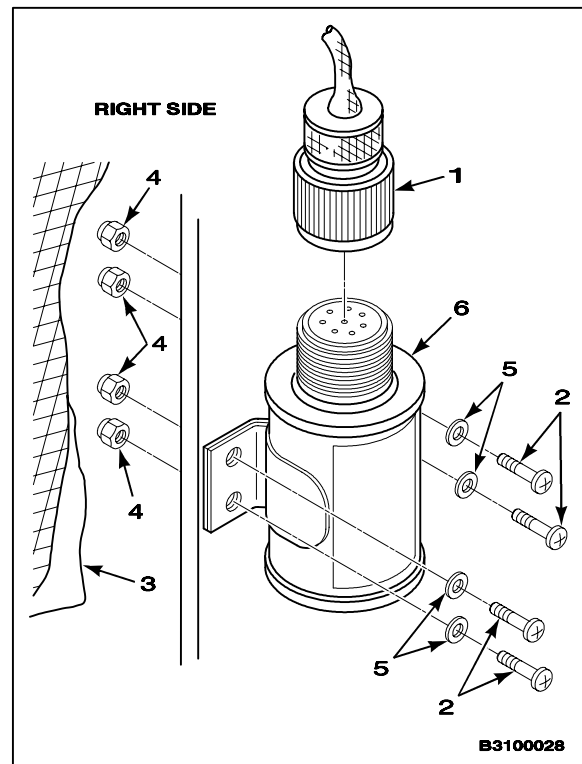

**LEFT SIDE CONTROL**

6. Remove lockwire from plug (7) and screw (8).
7. Disconnect plug (7).
8. Remove four screws (8) and washers (9).
9. Remove control (10).

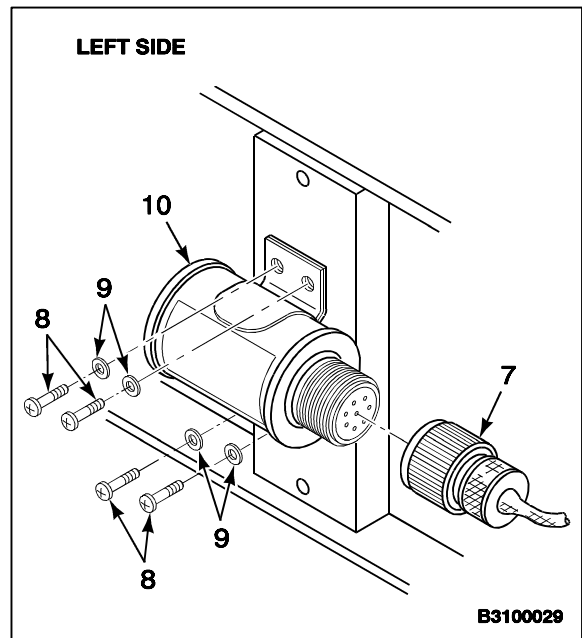
**FOLLOW-ON MAINTENANCE:**

None

END OF TASK

INITIAL SETUP

**Applicable Configurations:**

All

**Tools:**

Electrical Repairer's Tool Kit, NSN 5180-00-323-4915

**Materials:**

Lockwire (E231)

**Personnel Required:**

Aircraft Electrician  
Inspector

**References:**

TM 55-1520-240-23P

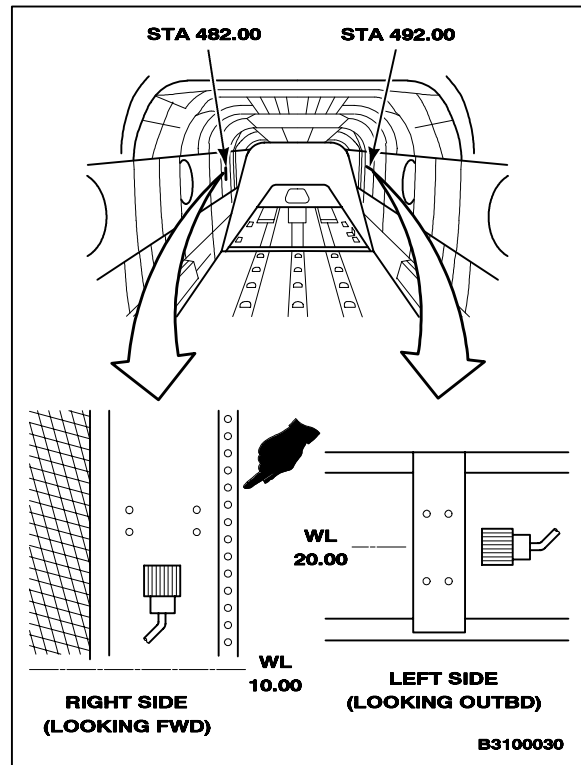

**NOTE**

If installing right side control, perform steps 1 thru 5. If installing left side control, perform steps 6 thru 9.

**RIGHT SIDE CONTROL**

1. Position control (1) on structure (2).
2. Install slotted screw (3), two washers (4), and nut (5).
3. Install three crosstip screws (6), washers (4), and nuts (5).
4. Connect plug (7). Lockwire plug to screw (3). Use lockwire (E231).

**INSPECT**

5. Install blanket (8).

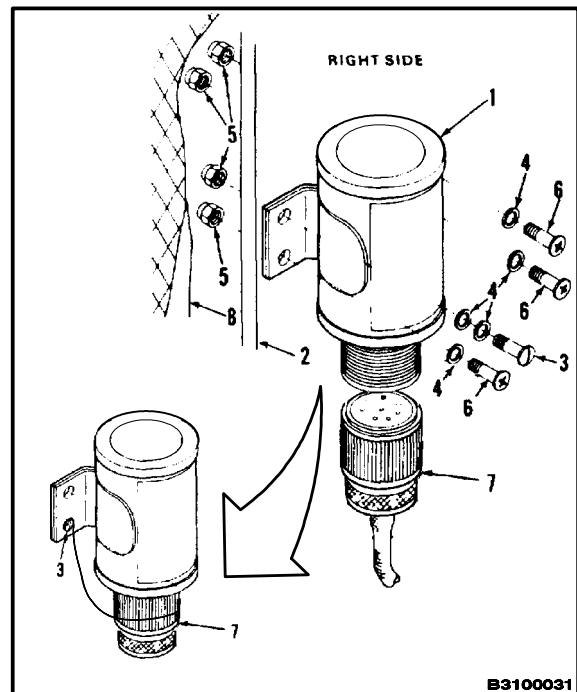

**LEFT SIDE CONTROL**

6. Position control (9) on structure (10).
7. Install slotted screw (11) and washer (12).
8. Install three crosstip screws (13) and washers (12).
9. Connect plug (14). Lockwire plug to screw (11). Use lockwire (E231).

**INSPECT**

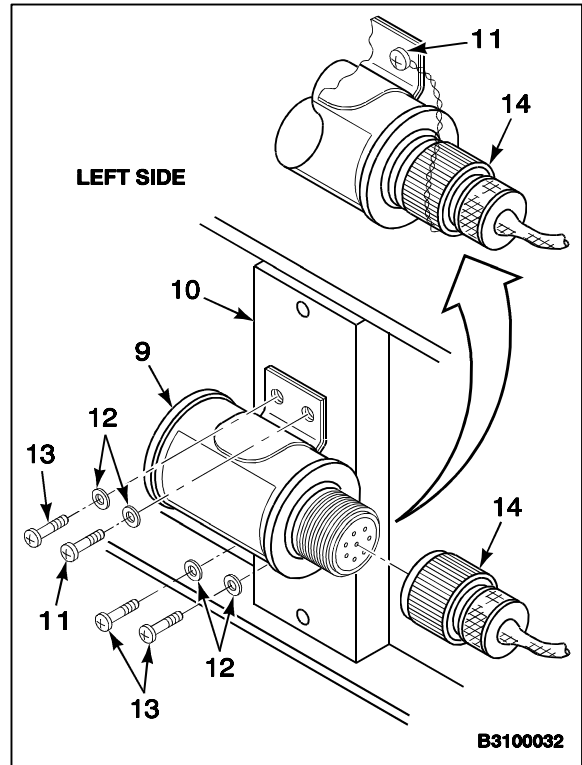

**FOLLOW-ON MAINTENANCE:**

Perform operational check of fire detection system (TM 55-1520-240-T).

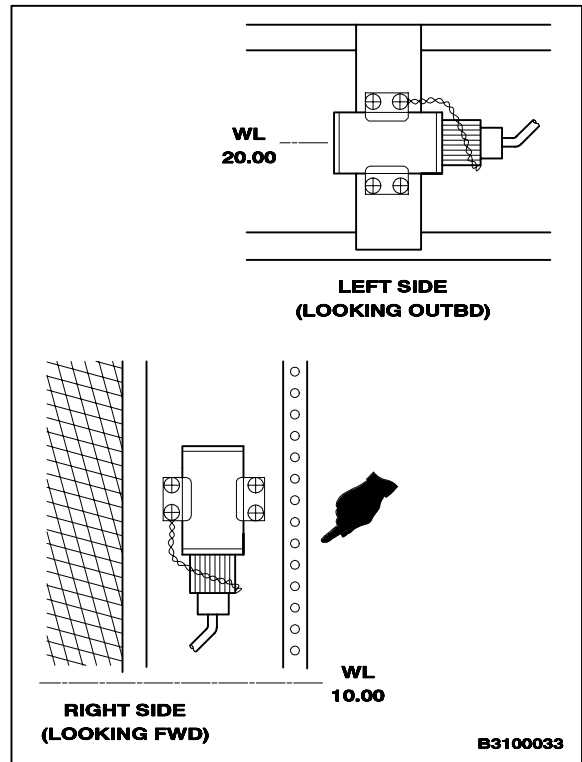

END OF TASK

INITIAL SETUP

**Applicable Configurations:**

All

**Tools:**

- Electrical Repairer's Tool Kit, NSN 5180-00-323-4915
- Exhaust Gas Temperature Tester (BH 112JB-53)
- Multimeter
- Stopwatch
- Torque Wrench, 30-150 Inch-Pounds
- Crowfoot Attachment, 3/8 Inch

**Materials:**

None

**Personnel Required:**

- Aircraft Electrician
- Inspector

**References:**

TM 55-4920-401-13

**Equipment Condition:**

- Battery Disconnected (Task 1-39)
- Electrical Power Off
- Engine Work Platform Open (Task 2-2)
- Engine Access Cover Open (Task 4-49)

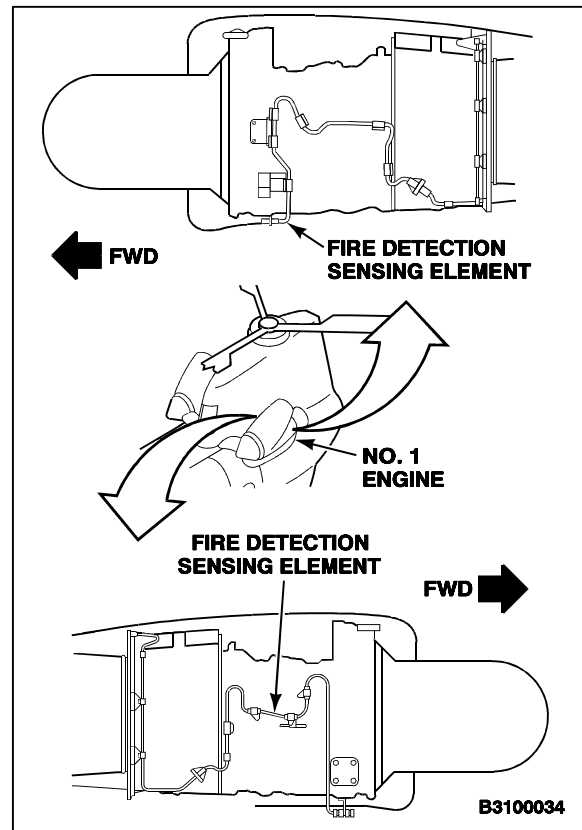

**NOTE**

Procedure is same to test fire detection sensing element on No. 1 or No. 2 engine. No. 1 engine is shown here.

1. Disconnect two cables (1) from two fuselage connectors (2). Make sure inserts (3) stay in connectors.

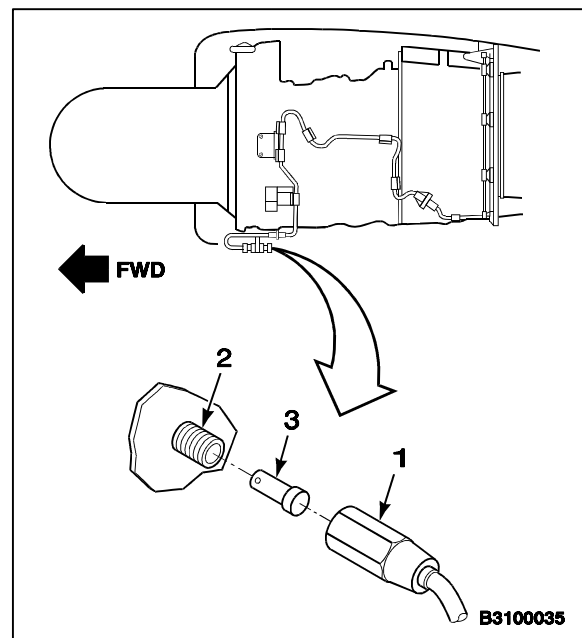

**12-10 TEST FIRE DETECTION SENSING ELEMENT (Continued)**

12-10

2. Connect multimeter (4), set to RX1, to inner conductor (5) and outer conductor (6) of cable (1). Multimeter shall read infinity.

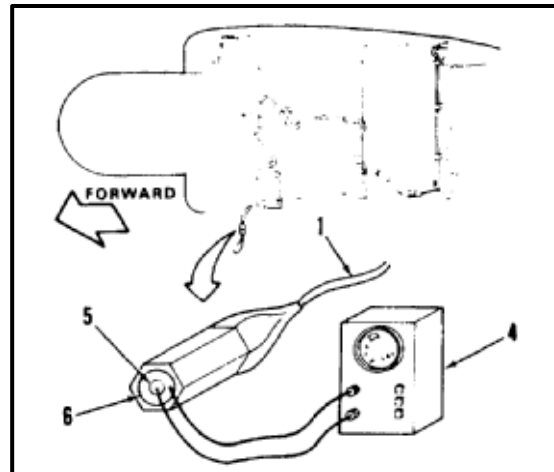

3. Connect probe (7) to element (8). Set tester (9) to **301°C**.
4. Operate tester (9) (TM 55-4920-401-13).
5. Check multimeter (4). Multimeter shall read **25 ohms**.
6. Turn off tester (9). Remove probe (7).
7. Wait **10 minutes** and check multimeter (4). Multimeter shall read infinity.
8. Disconnect multimeter (4).
9. Connect two cables (1) to two fuselage connectors (2). Torque cables to **65 inch-pounds**.

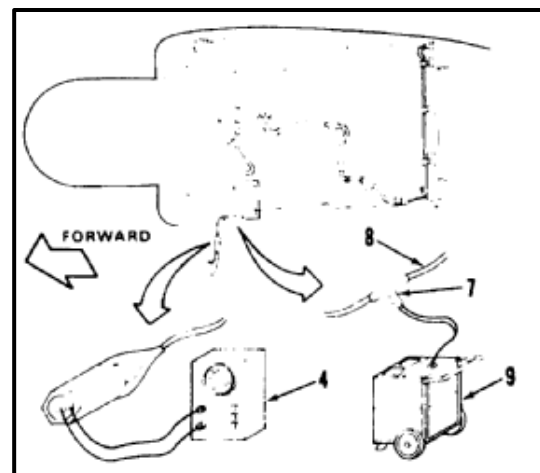
**WARNING**

Do not allow element to touch or chafe on engine or engine cover. Element can be damaged by chafing. A damaged element can cause a false fire indication or an inoperative fire detection system resulting in equipment damage and injury to personnel.

10. Check element (8). Element shall not chafe or touch engine (10) or engine cover (11).

**INSPECT****FOLLOW-ON MAINTENANCE:**

Perform operational check of fire detection system (TM 55-1520-240-T).  
 Close engine access cover (Task 4-50).  
 Close engine work platform (Task 2-2).

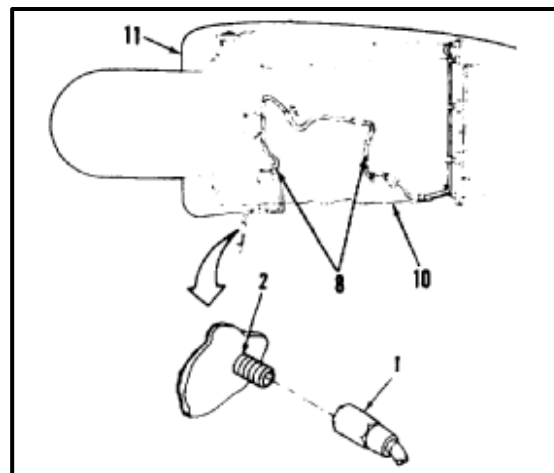

END OF TASK

## INITIAL SETUP

**Applicable Configurations:**

All

**Tools:**

Technical Inspection Tool Kit, NSN 5180-00-323-5114

**Materials:**

None

**Personnel Required:**

Inspector

**Equipment Condition:**

Battery Disconnected (Task 1-39)  
 Electrical Power Off  
 Engine Work Platform Open (Task 2-2)  
 Engine Access Cover Open (Task 4-49)

**References:**

TM 1-1500-204-23

**NOTE**

Procedure is same to inspect fire detection sensing element on No. 1 or No. 2 engine. No. 1 engine is shown here.

1. Replace fire detector element only if test or alarm circuit shows malfunction.

**WARNING**

Do not allow element to touch or chafe on engine or engine cover. Element can be damaged by chafing. A damaged element can cause a false fire indication or an inoperative fire detection system resulting in equipment damage and injury to personnel.

2. Element (1) shall not touch engine (2) or cover (3).

**FOLLOW-ON MAINTENANCE:**

Close engine access cover (Task 4-50).  
 Close engine work platform (Task 2-2).

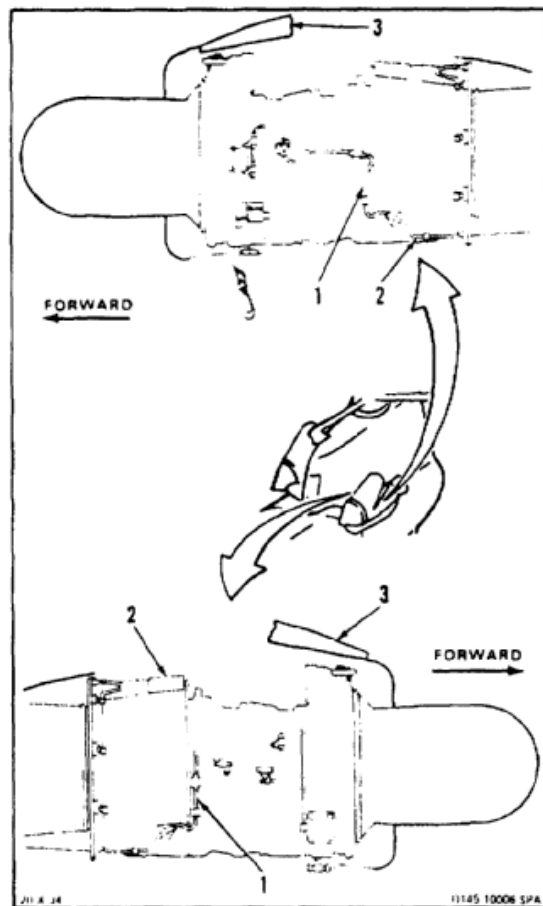

END OF TASK



**12-12 REMOVE FIRE DETECTION SENSING ELEMENT**

12-12

**INITIAL SETUP****Applicable Configurations:**

All

**Tools:**

Aircraft Mechanic's Tool Kit, NSN 5180-00-323-4692

**Materials:**

As Required

**Personnel Required:**

Medium Helicopter Repairer

**Equipment Condition:**

Battery Disconnected (Task 1-39)  
 Electrical Power Off  
 Engine Work Platform Open (Task 2-2)  
 Engine Access Cover Open (Task 4-49)

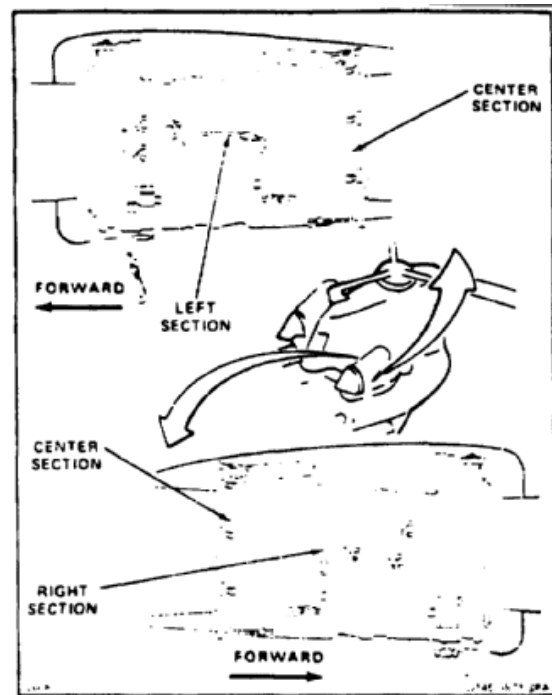

Do not pinch, crush, kink, or make sharp bends in element. Element can be damaged.

**NOTE**

Procedure is same to remove fire detection sensing element on No. 1 or No. 2 engines. Removal of No. 1 engine element is shown here.

**REMOVE LEFT SECTION****NOTE**

Left section is outboard on No. 1 engine, inboard on No. 2 engine.

1. Turn fastener (1) and release cable (2) and bushing (3) from clamp (4).
2. Disconnect cable (2) from connector (5) on fuselage. Make sure insert (6) stays in connector. Cap connector.

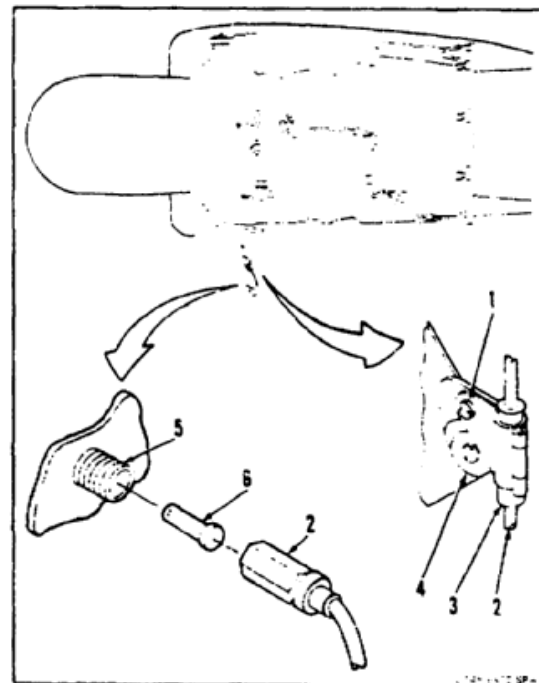

3. Disconnect element (7) from connector (8). Make sure insert (6) stays in connector.
4. Remove lockwire and nut (9) from connection (8). Remove cable (2) and bushing (3). Remove bushing from cable. Cap cable ends.
5. Disconnect element (7) from connector (10). Make sure insert (6) stays in connector.
6. Turn fastener (1) and release element (7) and bushings (3) from clamp (4) and six locations.
7. Remove left section of element (7).

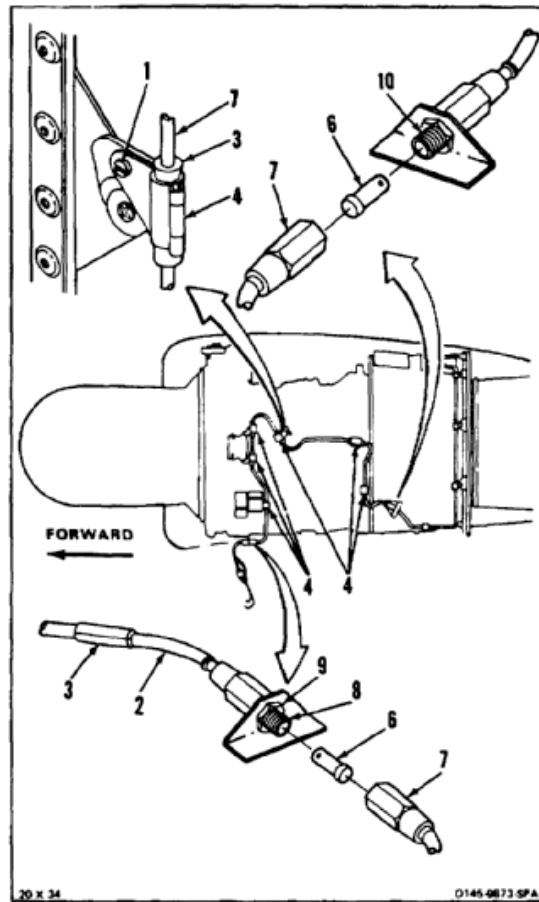

8. Cap ends of element (7). Remove six bushings (3) from element.

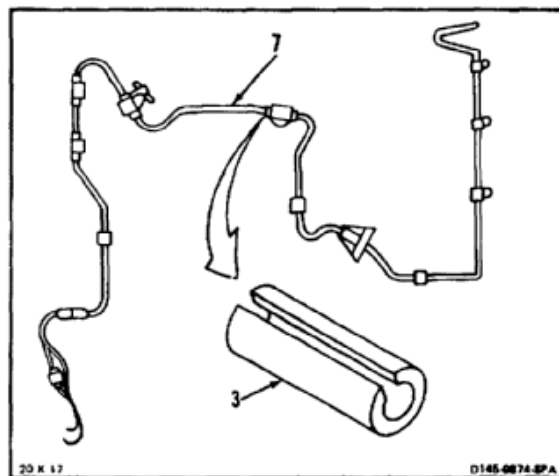

**REMOVE RIGHT SECTION****NOTE**

Right section is inboard on No. 1 engine, outboard on No. 2 engine.

9. Turn fastener (1) and release cable (11) and bushing (3) from clamp (4).
10. Disconnect cable (11) from connector (12) on fuselage. Make sure insert (6) stays in connector. Cap connector.
11. Disconnect element (13) from connector (14). Make sure insert (6) stays in connector.
12. Remove lockwire and nut (15) from connector (14). Remove cable (11) and bushing (3). Cap cable ends.

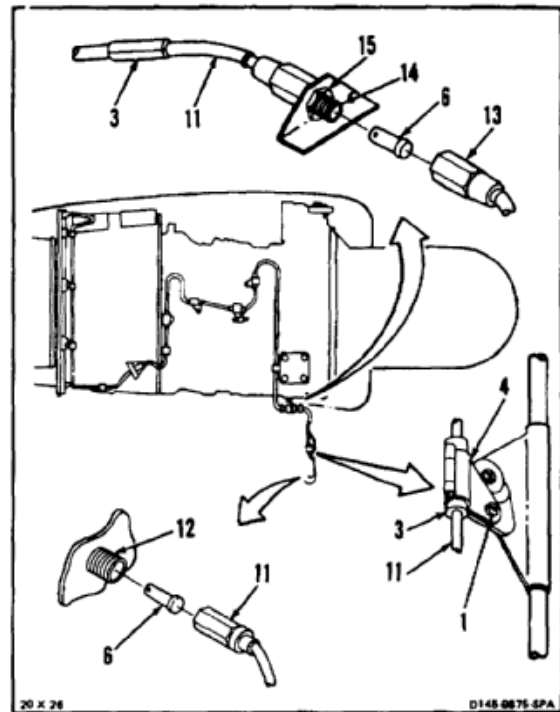

13. Disconnect element (13) from connector (16). Make sure insert (6) stays in connector.
14. Turn fastener (1) and release element (13) and bushing (3) from clamp (4) at six locations. Remove right section of element (13).

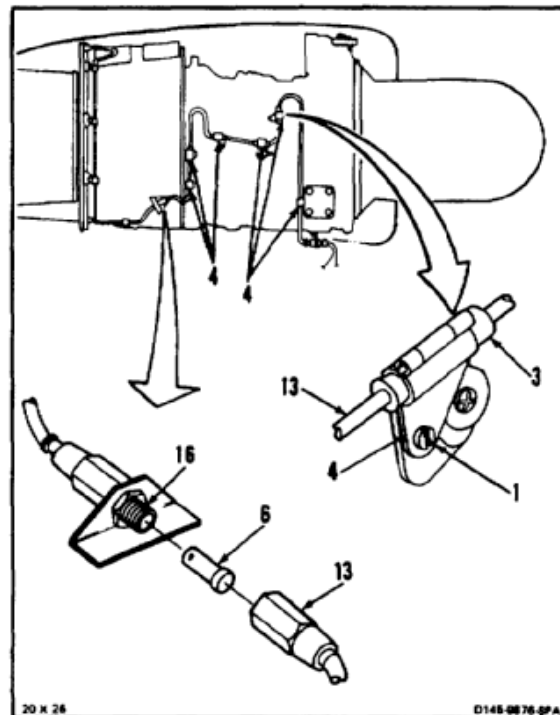

15. Cap ends of element (13). Remove six bushings (3) from element.

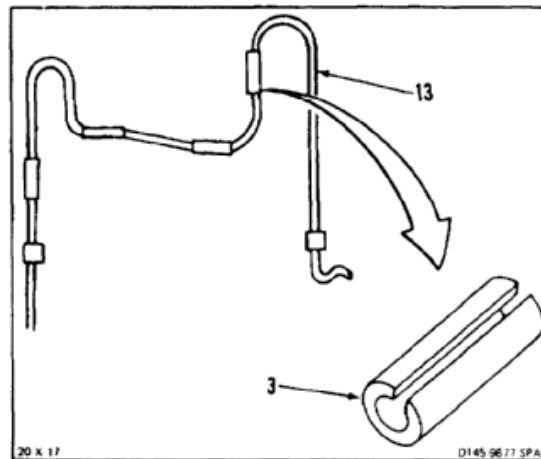

**REMOVE CENTER SECTION**

**NOTE**

Center section of element passes over top of engine to connect right and left sections of element.

16. Remove lockwire and nut (17). Remove element (18) from bracket (19).
17. Repeat step 16 to release element (18) on other side of engine (20).
18. Turn fastener (1) and release element (18) and bushing (3) from clamps (4) at 12 locations.
19. Remove center section of element (18).

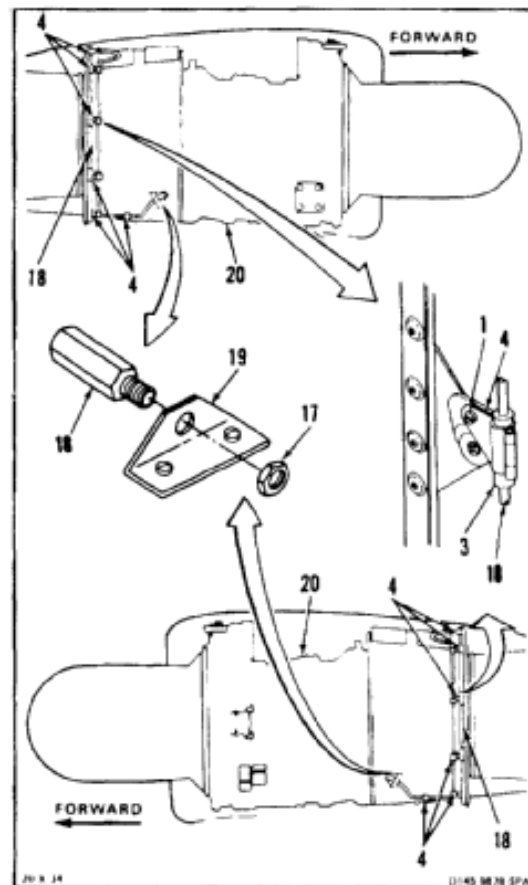

**12-12 REMOVE FIRE DETECTION SENSING ELEMENT (Continued)****12-12**

20. Cap ends of element (18). Remove 12 bushings (3) from element.

***FOLLOW-ON MAINTENANCE:***

None

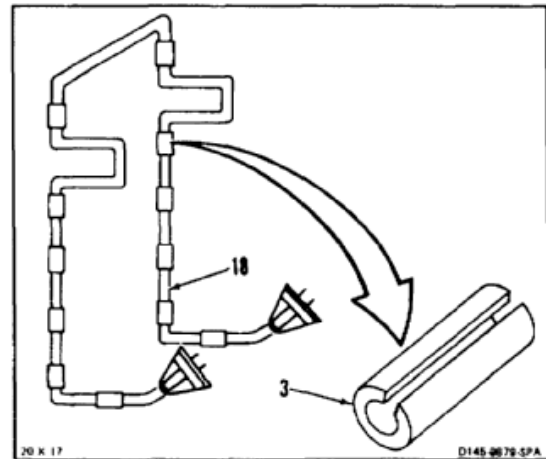

END OF TASK

INITIAL SETUP

**Applicable Configurations:**

All

**Tools:**

Aircraft Mechanic's Tool Kit, NSN 5180-00-323-4692  
 Torque Wrench, 30 to 150 Inch-Pounds  
 Crowsfoot Attachment, 3/8 Inch

**Materials:**

Lockwire (E231)

**Personnel Required:**

Medium Helicopter Repairer  
 Inspector

**References:**

TM 55-1520-240-23P



Do not pinch, crush, kink, or make sharp bends in element. Element can be damaged.

**NOTE**

Procedure is same to install fire detection sensing element on No. 1 or No. 2 engine. Installation of No. 1 engine element is shown here.

**INSTALL CENTER SECTION**

**NOTE**

Center section of element passes over top of engine to connect right and left sections of element.

1. Remove caps from element (1).
2. Bend element (1) as shown. Element must follow locations of 12 clamps (2) and two brackets (3).
3. Follow these guidelines when bending element (1).
  - a. Bend radius shall not be less than **1 inch**.
  - b. Bends shall be at least **3 inches** from brackets (3).
  - c. Bends shall be at least **1/2 inch** from clamps (2).

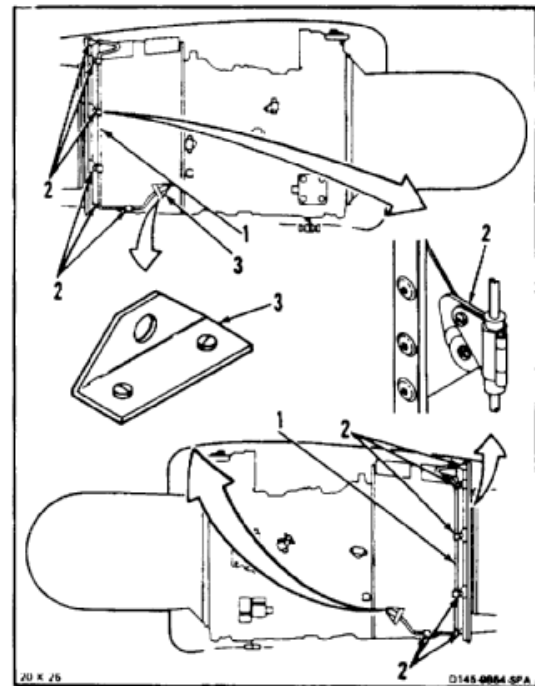
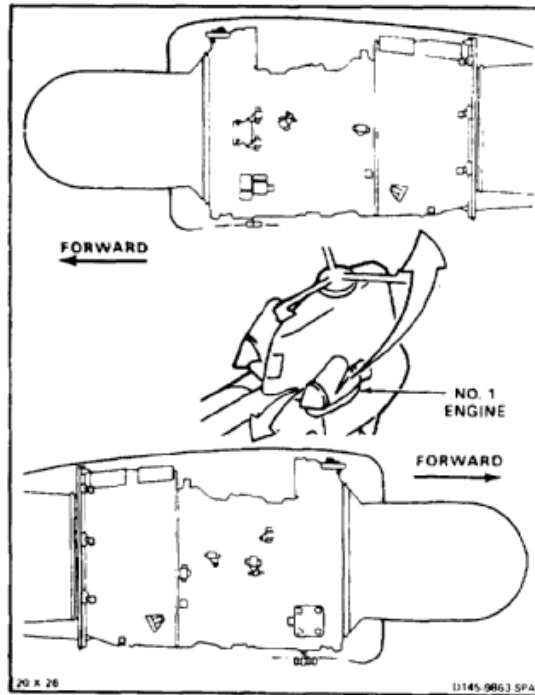

4. Insert end of element (1) through bracket (3). Install and lockwire nut (4). Use lockwire (E231).
5. Repeat step 4 for bracket (3) on other side of engine (5).
6. Install 12 bushings (6) on element (1), one at each clamp (2) location. Slits in bushings shall be toward outside of bends in element.
7. Press element (1) and bushing (6) into clamp (2) at 12 locations. Bushings shall be centered in clamps.
8. Lock each clamp (2) with fasteners (7).

**INSTALL RIGHT SECTION**

**NOTE**

Right section of element is inboard on No. 1 engine, outboard on No. 2 engine.

9. Remove caps from elements (8).
10. Bend element (8) as shown. Element must follow locations of six clamps (2) and two brackets (3 and 9). Follow guidelines in step 3 when bending element.
11. Make sure insert (10) is in connector (11), white dot (12) first.
12. Connect element (8) to connector (11) at bracket (3).
13. Install six bushings (6) on element (8), one at each clamp (2) location. Slits in bushings shall be toward outside of bends in element.
14. Press element (8) and bushing (6) into clamp (2) at six locations. Bushings shall be centered in clamps.
15. Lock each clamp (2) with fastener (7).
16. Torque end of element (8) to **65 inch-pounds**.

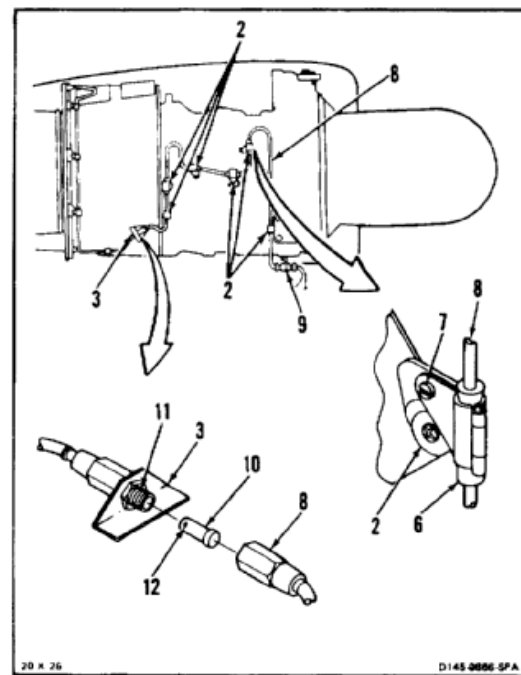
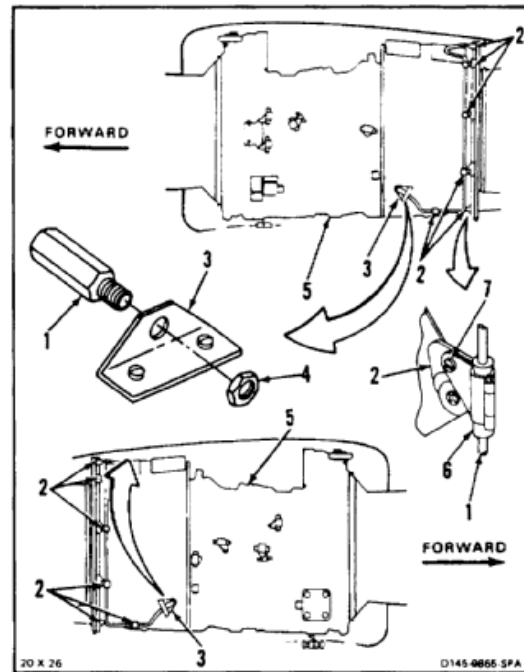

17. Remove caps from cable (13) and connector (14) on fuselage.
18. Insert connector (15) through bracket (9).
19. Install and lockwire nut (4). Use lockwire (E231).
20. Make sure insert (10) is in two connectors (14 and 15), white dot (12) first.
21. Connect cable (13) to connector (14) on fuselage. Torque cable to **65 inch-pounds**.
22. Connect element (8) to connector (15) at bracket (9). Torque cable to **65 inch-pounds**.
23. Install bushing (6) on cable (13) at clamp (2) location.
24. Press cable (13) and bushing (6) into clamp (2). Bushing shall be centered in clamp.
25. Lock clamp (2) with fastener (7).

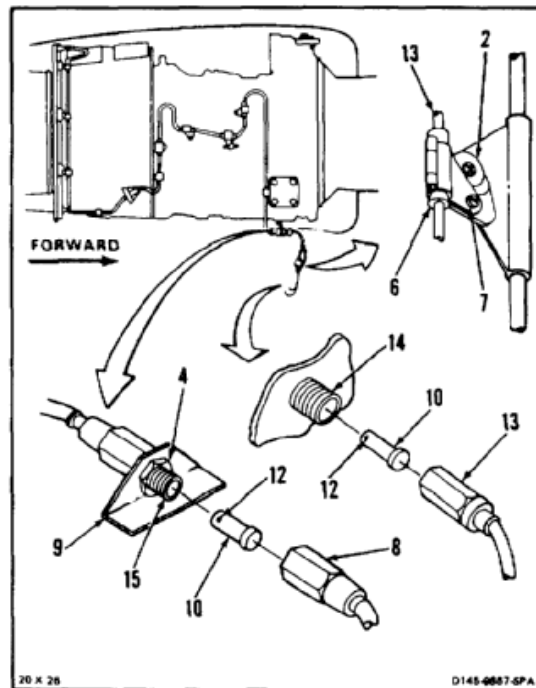



**INSTALL LEFT SECTION****NOTE**

Left section of element is outboard on No. 1 engine, inboard on No. 2 engine.

26. Remove caps from element (16).
27. Bend element (16) as shown. Element must follow locations of six clamps (2) and two brackets (3 and 9). Follow guidelines in step 3 when bending element.
28. Make sure insert (10) is in connector (17), white dot (12) first.
29. Connect element (16) to connector (17) at bracket (3).
30. Install six bushings (6) on element (16), one at each clamp (2) location. Slits in bushings shall be toward outside of bends in element.
31. Press element (16) and bushing (6) into clamp (2) at six locations. Bushings shall be centered in clamps.
32. Lock each clamp (2) with fastener (7).
33. Torque end of element (16) to **65 inch-pounds**.

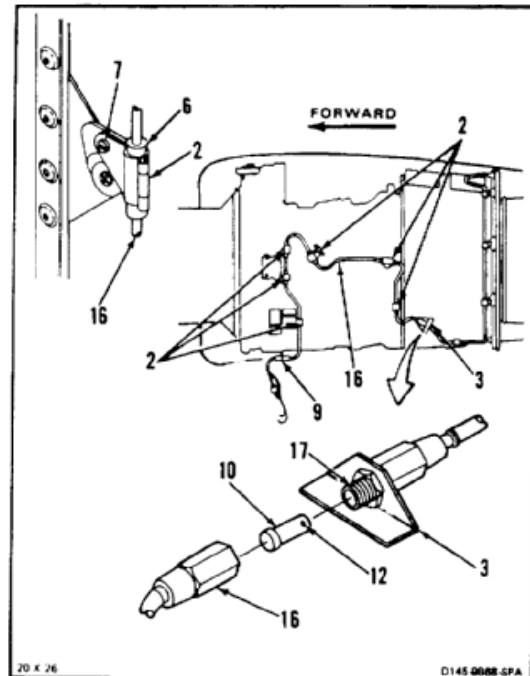

34. Remove caps from cable (18) and connector (19) on fuselage. Insert connector (20) through bracket (9).
35. Install and lockwire nut (21). Use lockwire (E231).
36. Make sure insert (10) is in connectors (19 and 20), white dot (12) first.
37. Connect cable (18) to connector (19) on fuselage. Torque cable to **65 inch-pounds**.
38. Connect element (16) to connector (20) at bracket (9). Torque element to **65 inch-pounds**.
39. Install bushing (6) on cable (18) at clamp (2).
40. Press cable (18) and bushing (6) into clamp (2). Bushing shall be centered in clamp.
41. Lock clamp (2) with fastener (7).

**INSPECT**

**WARNING**

Do not allow element to touch or chafe on engine or engine cover. Element can be damaged by chafing. A damaged element can cause a false fire indication or an inoperative fire detection system resulting in equipment damage and injury to personnel.

42. Check elements (1, 8, and 16). Elements shall not chafe or touch engine (5) or engine cover (21).

**FOLLOW-ON MAINTENANCE:**

Close engine access cover (Task 4-50).  
 Close engine work platform (Task 2-2).  
 Perform operational check of fire detection system (TM 55-1520-240-T).

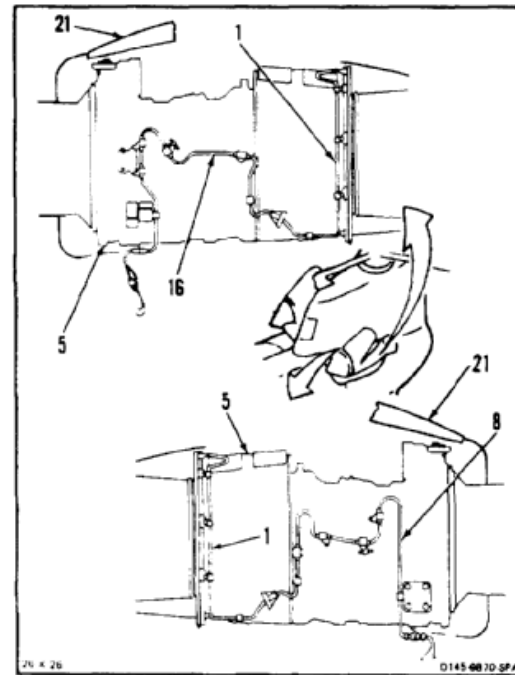
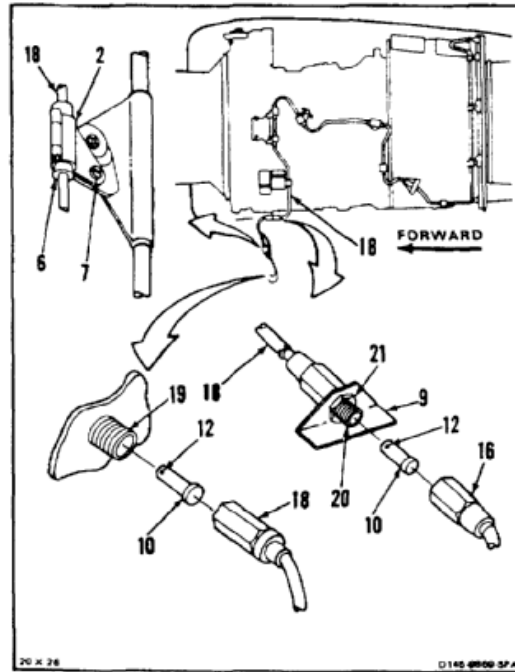

END OF TASK

## INITIAL SETUP

**Applicable Configurations:**

All

**Tools:**

Aircraft Mechanic's Tool Kit, NSN 51 80-00-323-4692

**Materials:**

None

**Personnel Required:**Medium Helicopter Repairer  
Inspector**Equipment Condition:**Battery Disconnected (Task 1-39)  
Electrical Power Off  
Hydraulic Power Off**References:**

TM 55-1520-240-23P

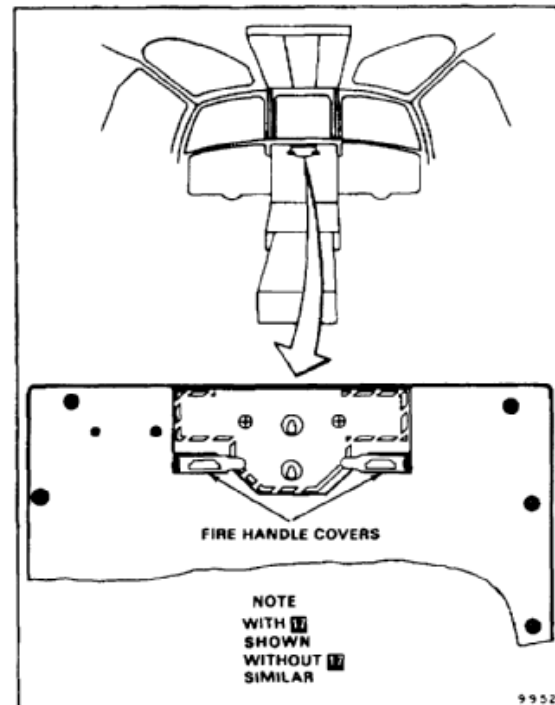
**REMOVE COVER ASSEMBLY WITH [17]****NOTE**

Procedure is similar to replace left or right fire handle cover. Replacement of left cover is shown.

1. Remove two screws (1), washers (2), and locknuts (3).
2. Remove lid (4), bottom cover (5), and filter holder (6) from fire handle (7).

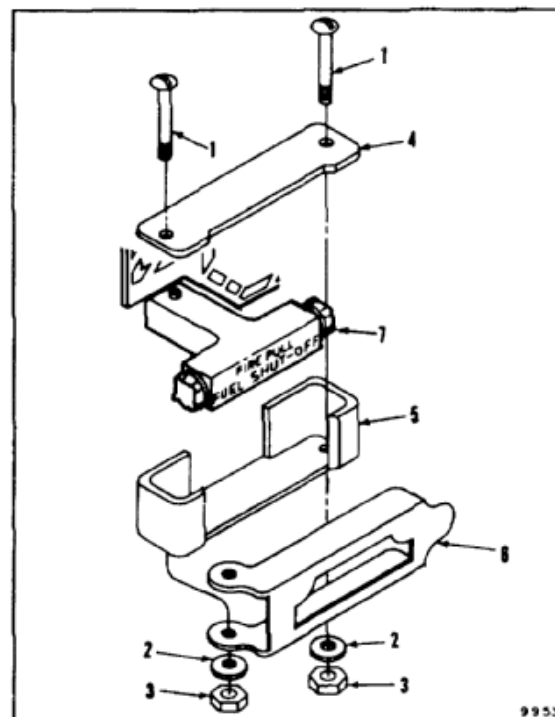

**REMOVE LAMP**

3. Remove holder lens (8) and seal or packing (9) from handle (7).
4. Separate lamp (10) from holder (8).

**INSTALL LAMP**

5. Install lamp (10) in holder (8).
6. Install holder (8) and packing (9) in handle (7).

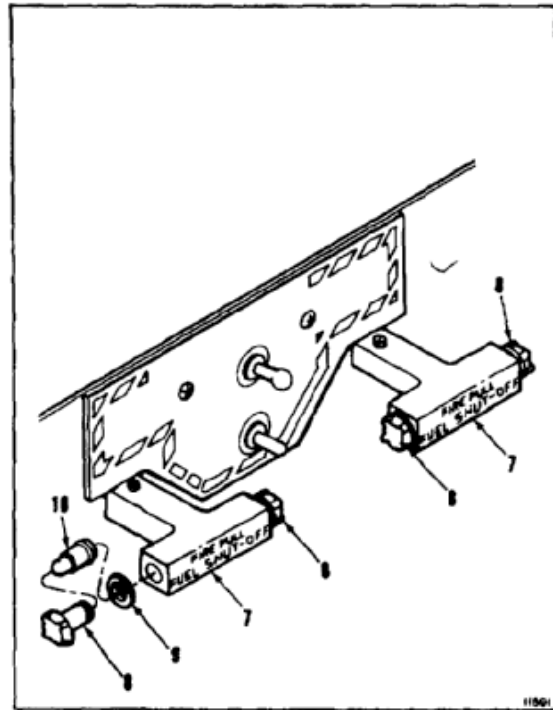
**INSTALL COVER ASSEMBLY WITH 17**

7. Position bottom cover (5) under fire handle (7).
8. Position lid (4) on top of fire handle (7).



Do not tighten self-locking nut when installing filter holder. Accidental actuation of fire extinguisher may result.

**NOTE**

Tab of filter holder on left fire handle is on right edge. Tab of filter holder on right fire handle is on left edge.

9. Position filter holder (5) on fire handle (7).
10. Install two screws (1), washers (2), and self-locking nuts (3) in fire handle (7).

**INSPECT****FOLLOW-ON MAINTENANCE:**

Perform operational check of fire extinguisher system (TM 55-1520-240-T).

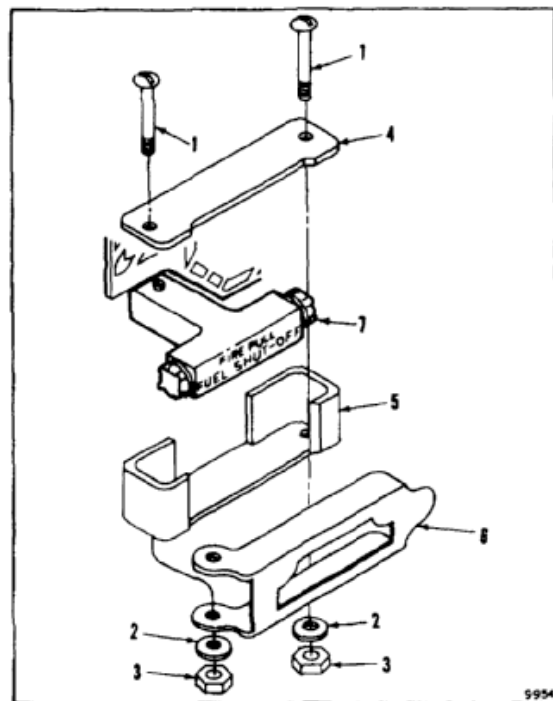

END OF TASK

**12-15 REMOVE FIRE PULL CONTROL**

12-15

**INITIAL SETUP****Applicable Configurations:**

All

**Tools:**

Electrical Repairer's Tool Kit, NSN 5180-00-323-4915

**Materials:**

Paper Tags (E264)

**Personnel Required:**

Aircraft Electrician

**Equipment Condition:**

Battery Disconnected (Task 1-39)  
 Electrical Power Off  
 Hydraulic Power Off

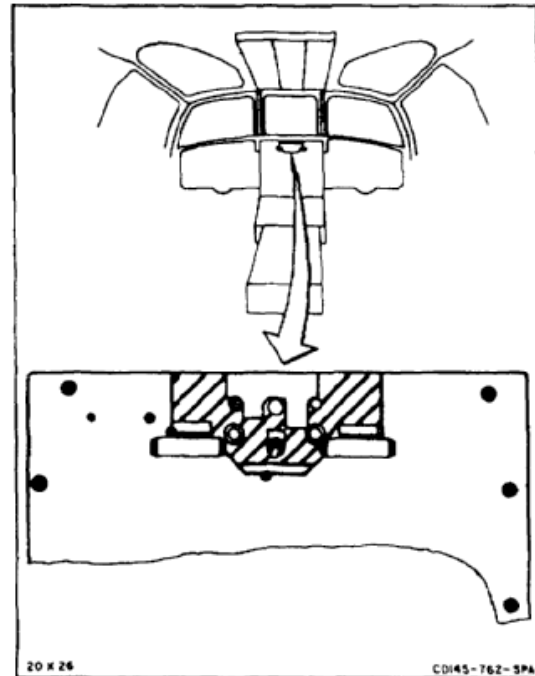
**NOTE**

There are two fire pull controls, one for each engine. Procedure is same for removing either one. Left side (No. 1 engine) is shown here.

Handle assemblies shown are without **17**. Handle assemblies with **17** are similar.

**ACCESS TO FIRE PULL CONTROL**

1. Pull handle (1).
2. Remove screw (2) and washer (3) from handle (1).
3. Remove handle (1).

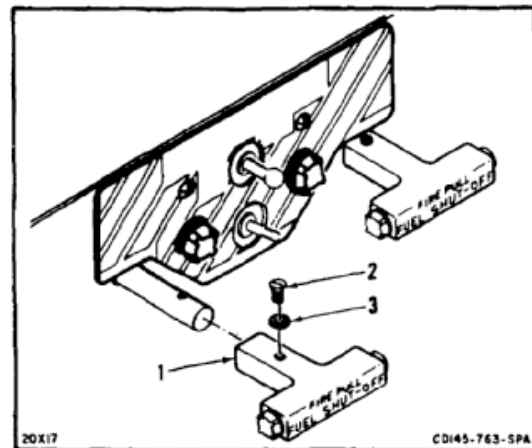

4. Remove two panel lights (4).
5. Remove 11 screws (5) and washers (6) from center instrument panel (7).
6. Tilt panel (7) far enough to see and reach behind it.
7. Remove two screws (8) from fire warning panel (9).
8. Remove panel (9).

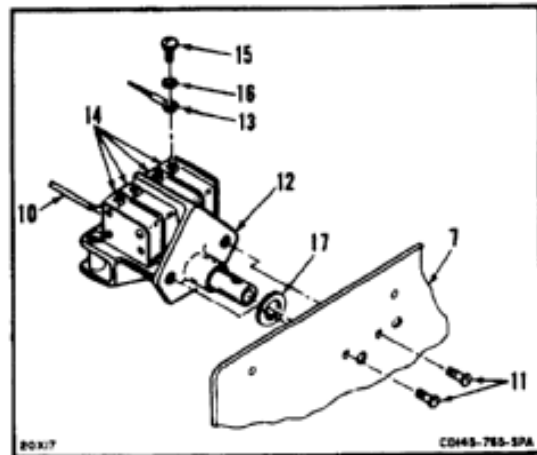

### REMOVE CONTROL ASSEMBLY

9. Tag and disconnect warning light electrical wires (10) at splice.
10. Remove two screws (11).
11. Separate control (12) from panel (7).
12. Tag eight electrical wires (13) connected to fire extinguisher switches (14). Disconnect eight wires by removing screws (15) and washers (16).
13. Remove control (12) and packing (17).

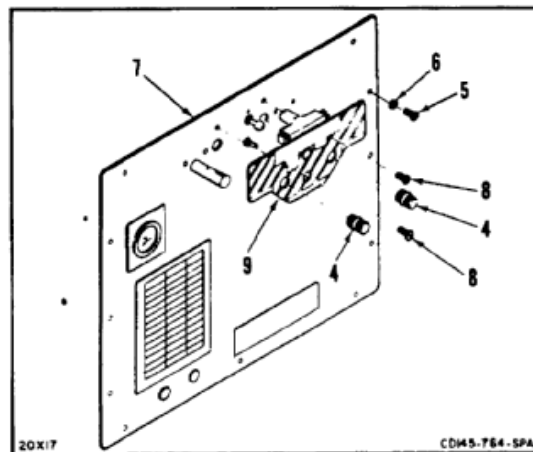

### FOLLOW-ON MAINTENANCE:

None

END OF TASK

**12-16 REMOVE FIRE EXTINGUISHER SYSTEM SWITCH AND ACTUATOR ADAPTER****12-16****INITIAL SETUP****Applicable Configurations:**

All

**Tools:**

Electrical Repairer's Tool Kit, NSN 5180-00-323-4915

**Materials:**

None

**Personnel Required:**

Aircraft Electrician

**Equipment Condition:**Off Helicopter Task  
Fire Pull Control Removed (Task 12-15)

1. Remove two nuts (1), washers (2), and screws (3).
2. Remove two plates (4), four adapters (5), and four switches (6) from control body (7).

**FOLLOW-ON MAINTENANCE:**

None

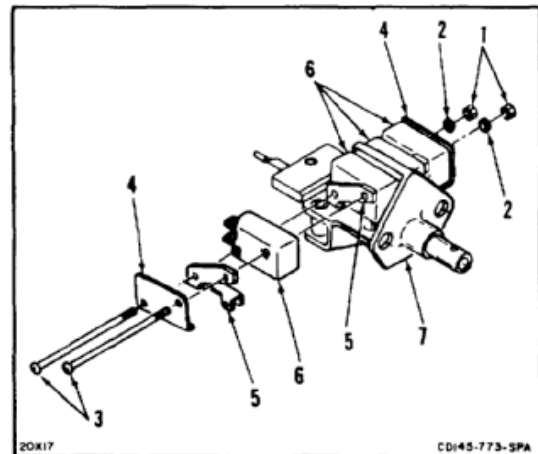

END OF TASK

## INITIAL SETUP

**Applicable Configurations:**

All

**Tools:**

Electrical Repairer's Tool Kit, NSN 5180-00-323-4915

**Materials:**

None

**Personnel Required:**Aircraft Electrician  
Inspector**References:**

TM 55-1520-240-23P

1. Position four adapters (1), four switches (2), and two plates (3) on control body (4) as shown.
2. Install two screws (5), washers (6), and nuts (7).

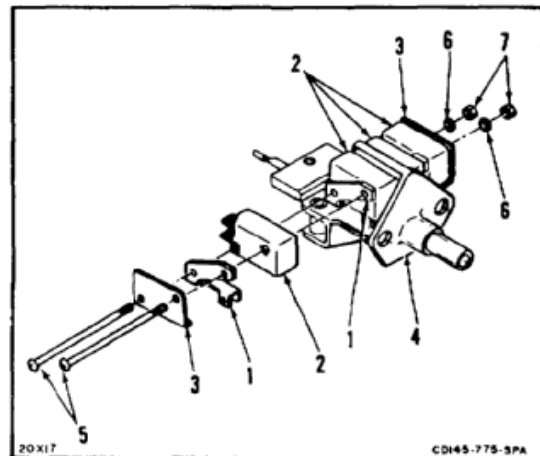
**INSPECT****FOLLOW-ON MAINTENANCE:**

None

END OF TASK

12-48



## INITIAL SETUP

**Applicable Configurations:**

All

**Tools:**

Electrical Repairer's Tool Kit, NSN 5180-00-323-4915  
Multimeter

**Materials:**

Electrical Insulation (E203)

**Parts:**

Preformed Packing

**Personnel Required:**

Aircraft Electrician  
Inspector

**References:**

TM 55-1520-240-23P

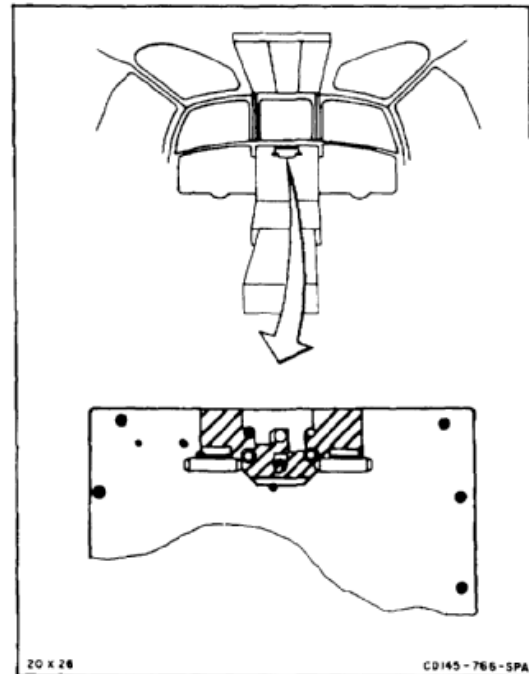
**NOTE**

There are two fire pull controls, one for each engine. Procedure is same for installing either one. Left side (No. 1 engine) is shown here.

**CONTINUITY TESTS**

1. Push in shaft (1).
2. Check for continuity between terminal (2) and terminal (3).
3. Repeat step 2 for each switch (4).

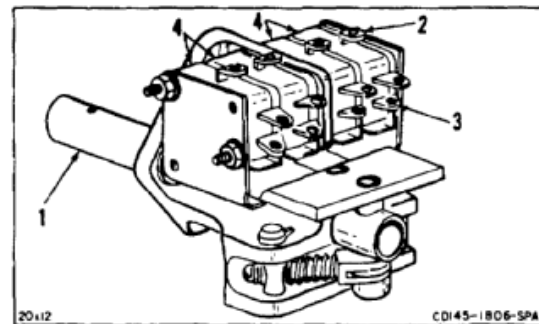

4. Pull out shaft (1).
5. Check continuity between terminal (2) and terminal (5).
6. Repeat step 5 for each switch (4).

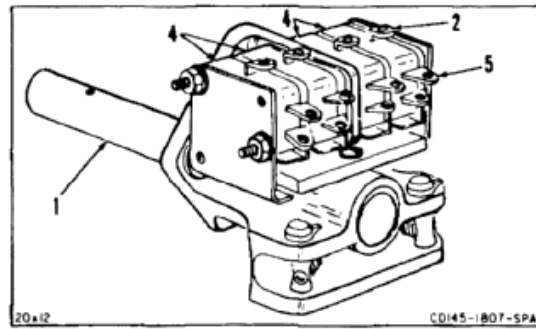

**INSTALL CONTROL**

7. Connect eight electrical wires (6) to switches (4). Install eight screws (7) and washers (8). Remove tags from wires.
8. Install packing (9) on control (10).
9. Install shaft (1) through hole (11) in instrument panel (12).
10. Install two screws (13).
11. Connect warning light electrical wires (14). Use splice and insulation (E203) to make connection. Remove tags from wires.

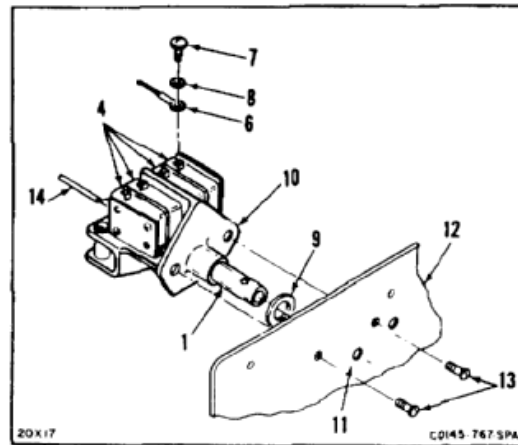

**INSTALL FIRE WARNING PANEL**

12. Position fire warning panel (15) on center instrument panel (12).
13. Install two screws (16).
14. Install two panel lights (17).

**INSPECT**

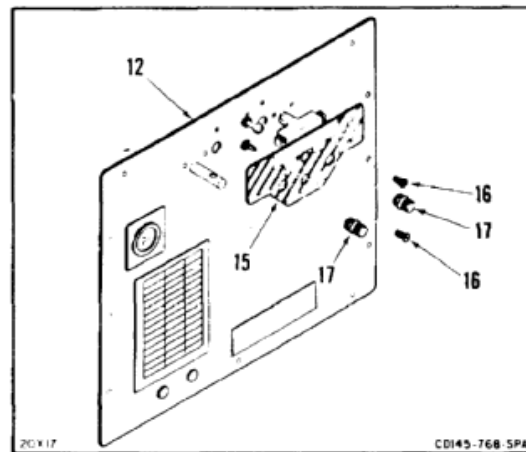

**INSTALL CENTER PANEL**

15. Position panel (12).
16. Install 11 screws (17) and washers (18).

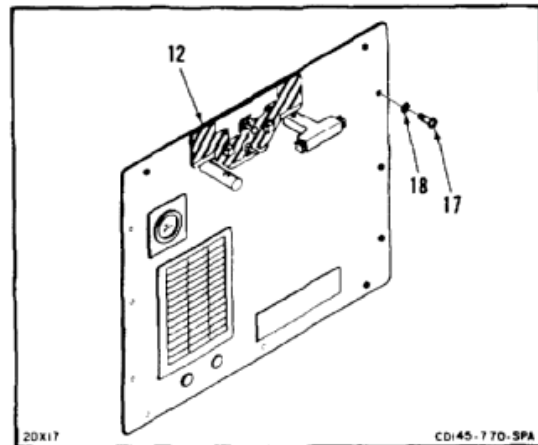
**INSTALL HANDLE**

17. Position handle (19) on shaft (1).
18. Install washer (20) and screw (21).
19. Push in handle (19).

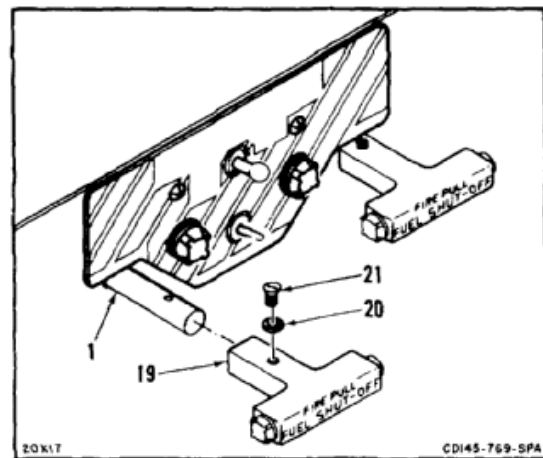
**INSPECT****FOLLOW-ON MAINTENANCE:**

Perform operational check (TM 55-1520-240-T).

END OF TASK

INITIAL SETUP

**Applicable Configurations:**

All

**Tools:**

Electrical Repairer's Tool Kit, NSN 5180-00-323-4915

**Materials:**

Paper Tags (E264)

**Personnel Required**

Aircraft Electrician

**Equipment Condition:**

Battery Disconnected (Task 1-39)  
 Electrical Power Off  
 Hydraulic Power Off

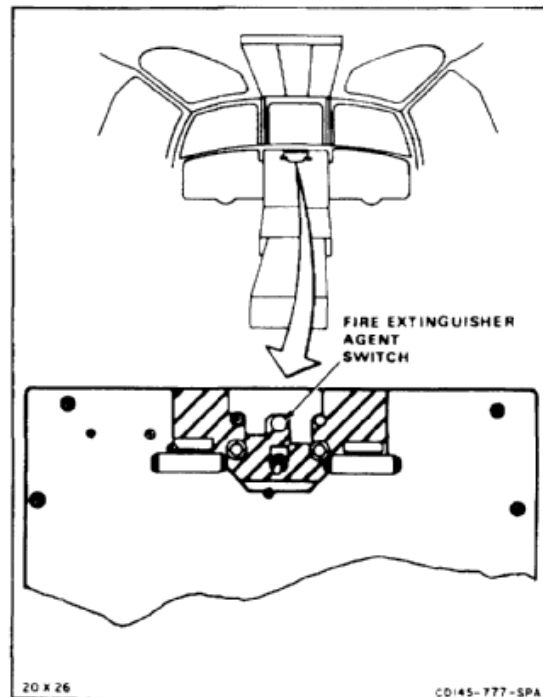

**ACCESS TO SWITCH**

1. Remove two panel lights (1).
2. Remove 11 screws (2) and washers (3) from center instrument panel (4).
3. Tilt panel (4) far enough to see and reach behind it.
4. Remove two screws (5) from fire warning panel (6).
5. Remove panel (6).

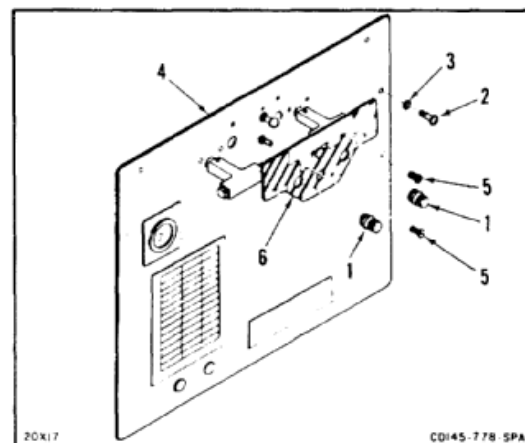

**SWITCH REMOVAL**

6. Tag six electrical wires (7) connected to FIRE EXT AGENT switch (8).
7. Disconnect wires (7) from switch (8) by removing six screws (9) and washers (10). Tag wires.
8. Remove nut (11) and washer (12) from switch (8).
9. Remove switch (8) with nut (11) and lockring (13) from behind panel (4).

**FOLLOW-ON MAINTENANCE:**

None

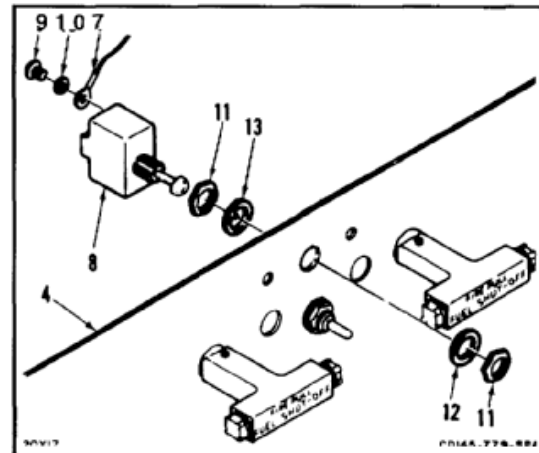

END OF TASK

INITIAL SETUP

**Applicable Configurations:**

All

**Tools:**

Electrical Repairer's Tool Kit, NSN 5180-00-323-4915

**Materials:**

None

**Personnel Required:**

Aircraft Electrician  
Inspector

**References:**

TM 55-1520-240-23P

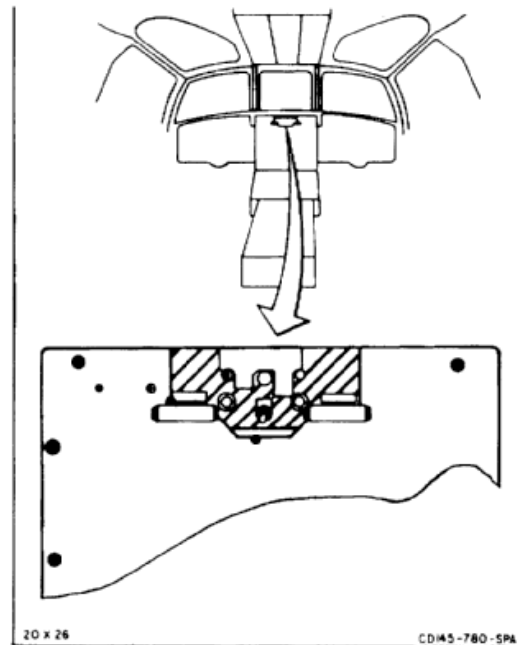

**SWITCH INSTALLATION**

1. Check that nut (1) and lockring (2) are installed on FIRE EXT AGENT switch (3).
2. Install switch (3) through hole (4) in center instrument panel (5). Be sure numbers 1 and 4 switch terminals (6) are at top.
3. Install washer (7) and nut (1) on switch (3).
4. Connect six electrical wires (8) to switch (3) with screws (9) and washers (10). Remove tags from wires.

**INSPECT**

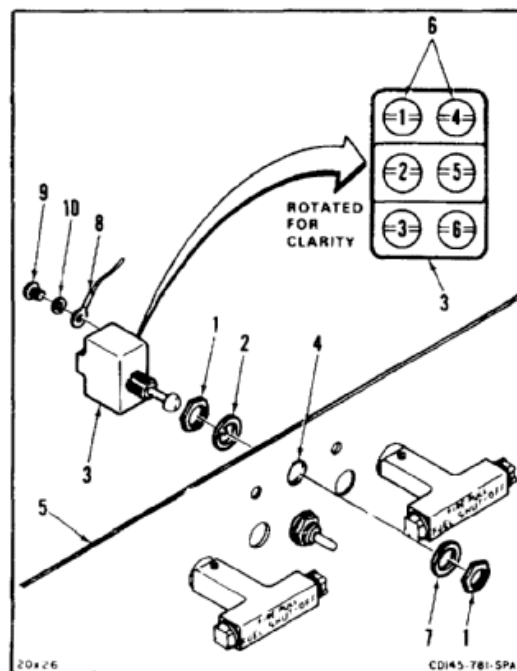

**PANEL INSTALLATION**

5. Position fire warning panel (11) on center instrument panel (5).
6. Install two screws (12).
7. Install two panel lights (13).
8. Position panel (5) as shown.
9. Install 11 screws (14) and washers (15).

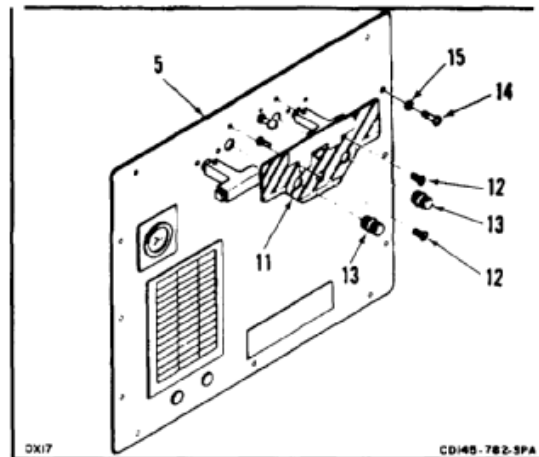
**INSPECT****FOLLOW-ON MAINTENANCE:**

Perform operational check of fire extinguisher system (TM 55-1520-240-T).

END OF TASK

## INITIAL SETUP

**Applicable Configurations:**

All

**Tools:**

Aircraft Mechanic's Tool Kit, NSN 5180-00-323-4692

**Materials:**

None

**Personnel Required:**

Medium Helicopter Repairer

**Equipment Condition:**

Battery Disconnected (Task 1-39)

Electrical Power Off

Engine Work Platform Opened (Task 2-2)

Open Engine Access Cover (Task 4-49)

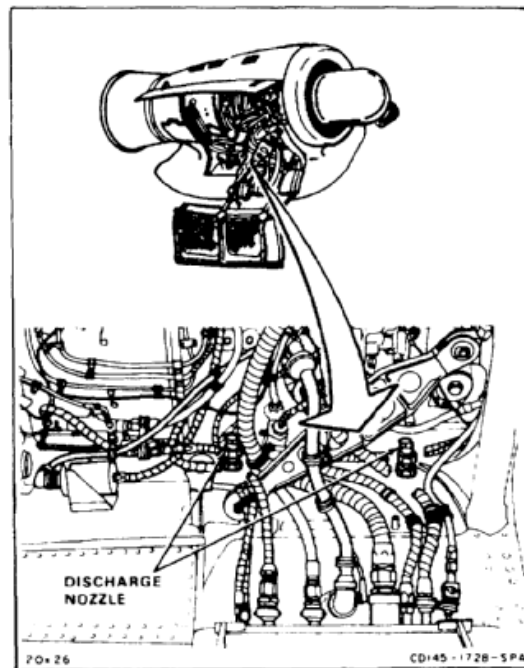
**NOTE**

There are two discharge nozzles in each engine compartment, one forward and one aft. Removal procedure is same for all nozzles.

1. Loosen nut (1).
2. Remove nozzle (2).
3. Cap fitting (3).

**FOLLOW-ON MAINTENANCE:**

None

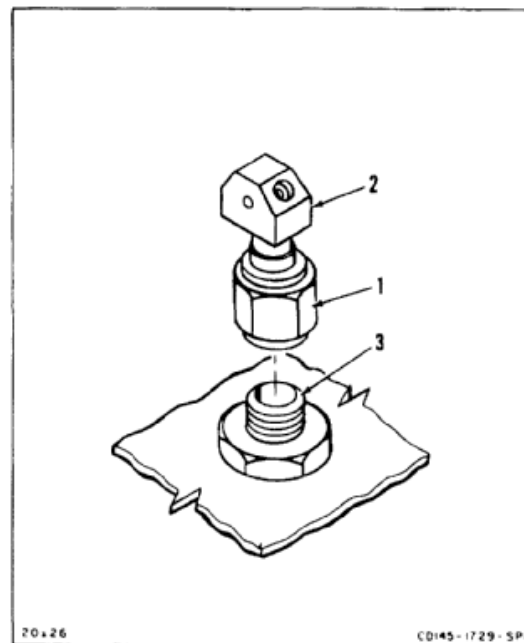

END OF TASK



## INITIAL SETUP

**Applicable Configurations:**

All

**Tools:**

Aircraft Mechanic's Tool Kit, NSN 51 80-00-323-4692

**Materials:**

Sealant (E334)

**Personnel Required:**Medium Helicopter Repairer  
Inspector**References:**

TM 55-1520-240-23P

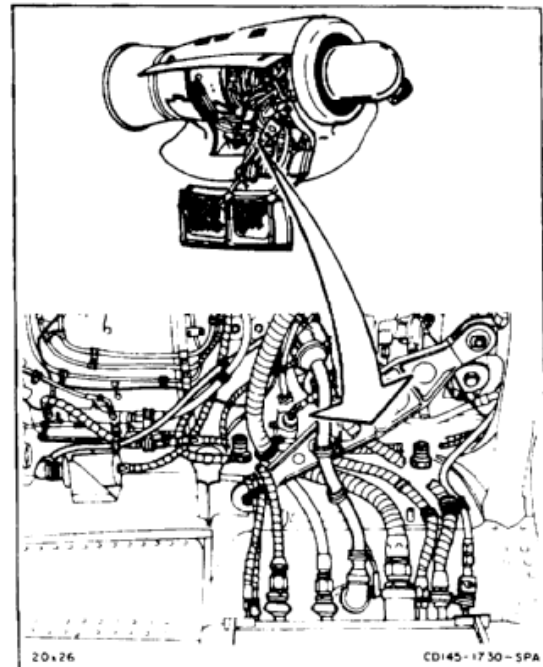
**NOTE**

There are two discharge nozzles in each engine compartment, one forward and one aft. Installation procedure is same for all nozzles.

Forward and aft nozzles are not same. Left and right aft nozzles are not same.

1. Remove caps from fitting (1).
2. Position nozzle (2) on fitting (1) as shown. For all nozzles, make sure two **1/4 inch** holes (3) point outboard and inboard. For aft nozzles, make sure **0.06 inch** hole (4) points aft and **30°** slope (5) is inboard.

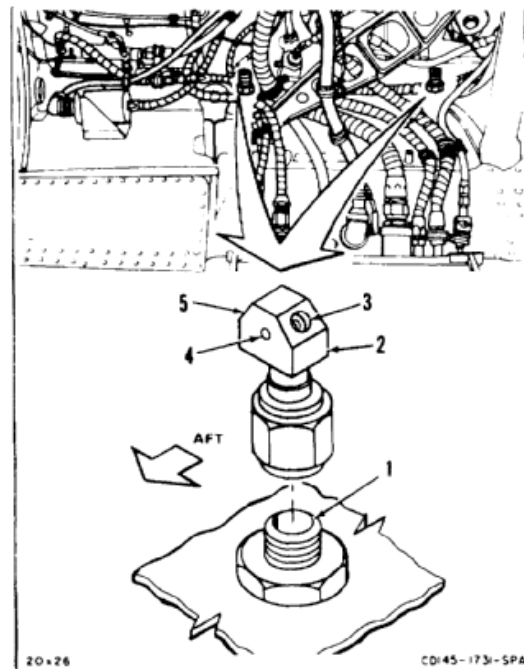

3. Hold nozzle (2) and tighten nut (6).
4. Check that two **1/4 inch** holes (3) point outboard and inboard. If nozzle (2) turned, loosen nut (6), align nozzle and tighten nut.
5. Check sealant around lower nut (7). If seal is cracked or damaged, apply sealant (E334) to lower nut.

**INSPECT****FOLLOW-ON MAINTENANCE:**

- Close engine access cover (Task 4-50).
- Close engine work platform (Task 2-2).

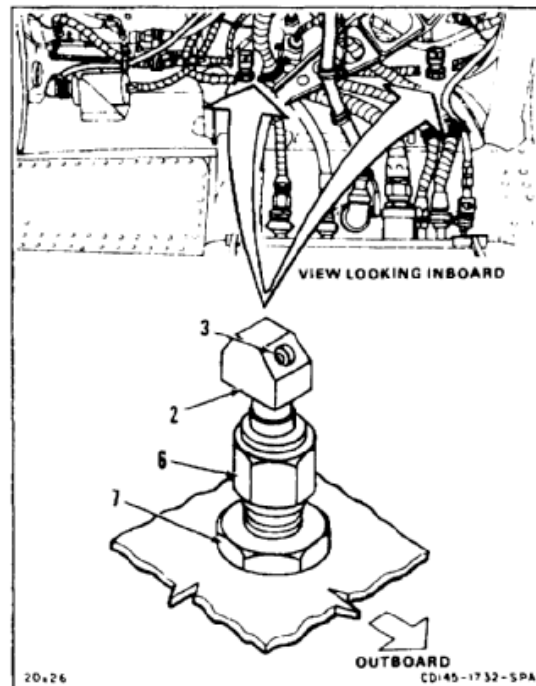

END OF TASK

**12-23 REMOVE FIRE EXTINGUISHER (BOTTLE) (30402103)**

12-23

**INITIAL SETUP****Applicable Configurations:**

All

**Tools:**

Aircraft Mechanic's Tool Kit, NSN 5180-00-323-4692  
 Open End Wrench, 1-1/2 Inch  
 Workstand

**Materials:**

Paper Tags (E264)  
 Lockwire (E231)

**Parts:**

Pressure Seal Cap

**Personnel Required:**

Medium Helicopter Repairer (2)

**Equipment Condition:**

Battery Disconnected (Task 1-39)  
 Electrical Power Off  
 Helicopter Grounded (Task 1-29)  
 FIRE EXT AGENT Switch in Center (OFF) Position  
 Both FIRE PULL Handles Pushed In

**General Safety Instructions:****WARNING**

When not mounted in helicopter, fire extinguishers (bottles) can become dangerous missiles if discharged. Do not detonate, discharge, or abuse fire extinguishers. Injury to personnel can result. Remove cartridges (squibs) when extinguishers are removed for storage.

**WARNING**

Do not attempt to perform a continuity test on the cartridge. It could fire and discharge the bottle.

**WARNING**

Shunt the unserviceable live cartridge. Tag the cartridge unserviceable. State the reason for its removal, the date it was installed, and the date it was removed. Place the unserviceable cartridge in same container that replacement cartridge was packed. Ship cartridge to the Ammunition Supply Activity.

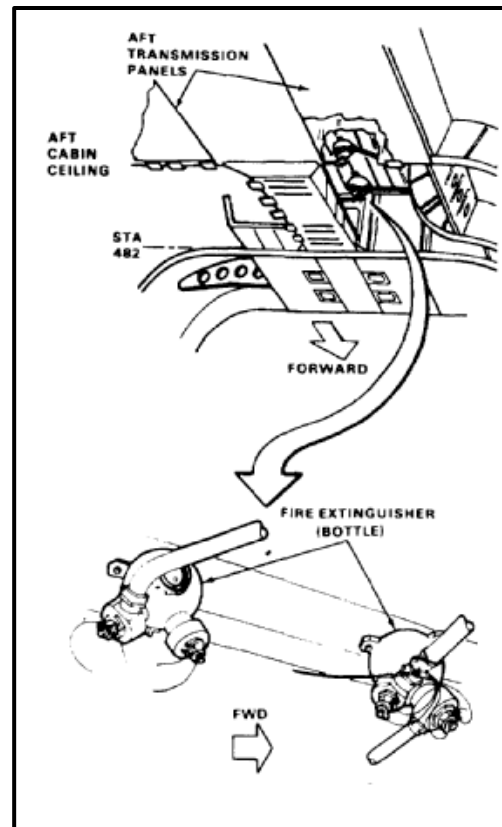

**NOTE**

There are two engine fire extinguishers in aft cabin ceiling.  
Removal procedure is same for both.

**DISCONNECT WIRING**

1. Remove four nuts (1). Tag and disconnect electrical wire (2) and ground wire (3) from both cartridges (4).

**WARNING**

Whenever fire extinguisher cartridges are not installed, the positive terminal and the ground terminal must be shorted to prevent firing from stray voltages.

2. Connect wire (E231) between electric terminal (5) and ground terminal (6) on each cartridge (4).

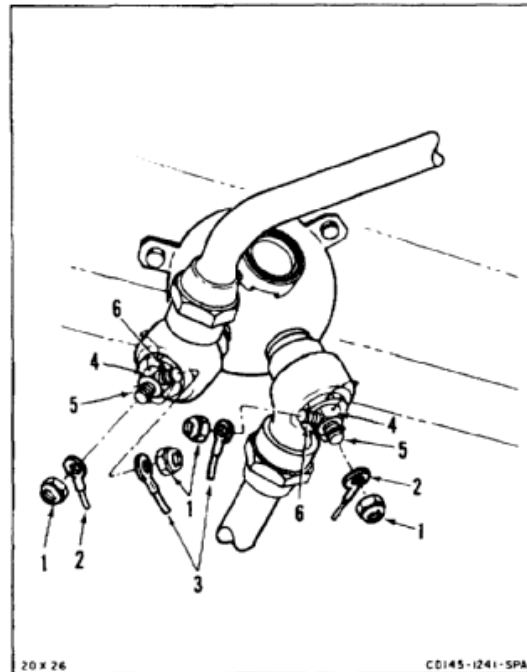
**REMOVE EXTINGUISHER**

3. Disconnect tubes (7) from both valves (8).
4. Remove three bolts (9) and washers (10).
5. Remove extinguisher (11).
6. Install pressure seal cap on both valves (8).
7. Plug or cap tubes (7).

**FOLLOW-ON MAINTENANCE:**

None

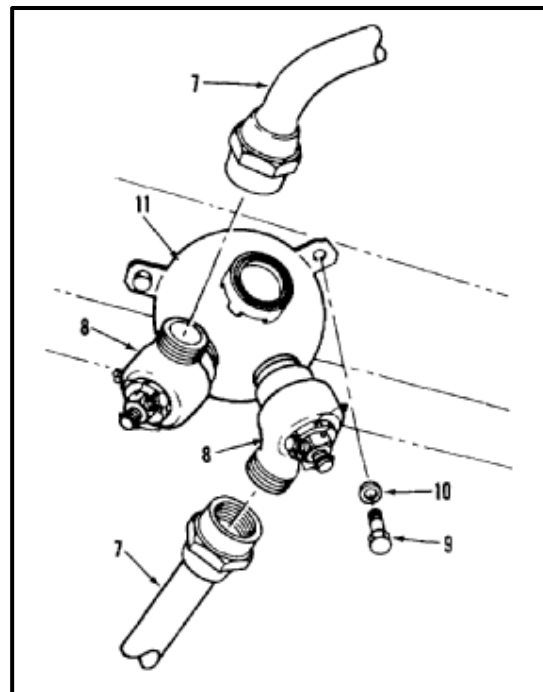

END OF TASK

## INITIAL SETUP

**Applicable Configurations:**

All

**Tools:**

Aircraft Mechanic's Tool Kit, NSN 5180-00-323-4692  
 Open End Wrench, 1-1/2 Inch  
 Workstand

**Materials:**

Lockwire (E231)  
 Paper Tags (E264)

**Parts:**

Pressure Seal Cap

**Personnel Required:**

Medium Helicopter Repairer (2)

**Equipment Condition:**

Battery Disconnected (Task 1-39)  
 Helicopter Grounded (Task 1-29)  
 Electrical Power Off  
 FIRE EXT AGENT Switch in Center (OFF) Position  
 Both FIRE PULL Handles Pushed In

**General Safety Instructions:****WARNING**

When not mounted in helicopter, fire extinguishers (bottles) can become dangerous missiles if discharged. Do not detonate, discharge, or abuse fire extinguishers. Injury to personnel can result. Remove cartridges (squibs) when extinguishers are removed for storage.

Do not attempt to perform a continuity test on the cartridge. It could fire and discharge the bottle.

Shunt the unserviceable live cartridge. Tag the cartridge unserviceable. State the reason for its removal, the date it was installed, and the date it was removed. Place the unserviceable cartridge in same container that replacement cartridge was packed. Ship cartridge to the Ammunition Supply Activity.

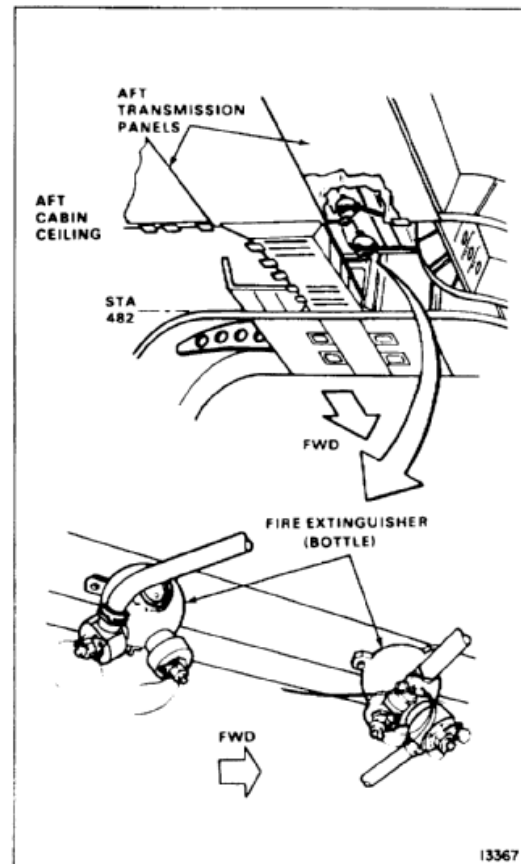
**CAUTION**

Make sure firing cartridge has been removed before packing bottle for shipment.

**NOTE**

There are two engine fire extinguishers in aft cabin ceiling. Removal procedure is same for both.

**NOTE**

Due to lack of supply stock availability of the cartridge (squib) for fire bottle 892868-02, use of bottle 30402103 is recommended.

**DISCONNECT WIRING**

1. Remove screw (1), washer (2), two nuts (3), and wire (4) from ground washer (5) on both cartridges (6). Tag wires.
2. Remove nut (3) and wire (7) from terminal (8) on both cartridges (6). Tag wires.
3. Connect a piece of wire (E231) between terminal (8) and ground washer (5) of each cartridge (6).

**WARNING**

Whenever fire extinguisher cartridges are not installed, the positive terminal and the ground terminal must be shorted to prevent firing from stray voltages.

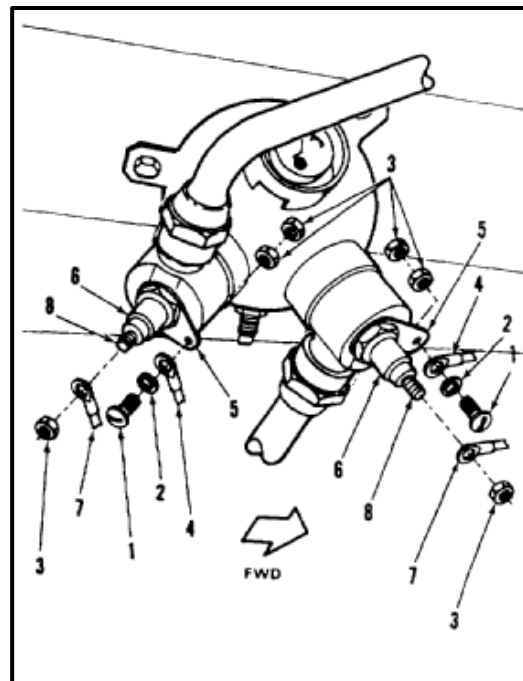
**REMOVE EXTINGUISHER**

4. Disconnect tubes (9) from both valves (10).
5. Remove three bolts (11) and washers (12).
6. Remove extinguisher (13).
7. Install pressure seal caps on both valves (10).
8. Plug or cap tubes (9).

**FOLLOW-ON MAINTENANCE:**

None

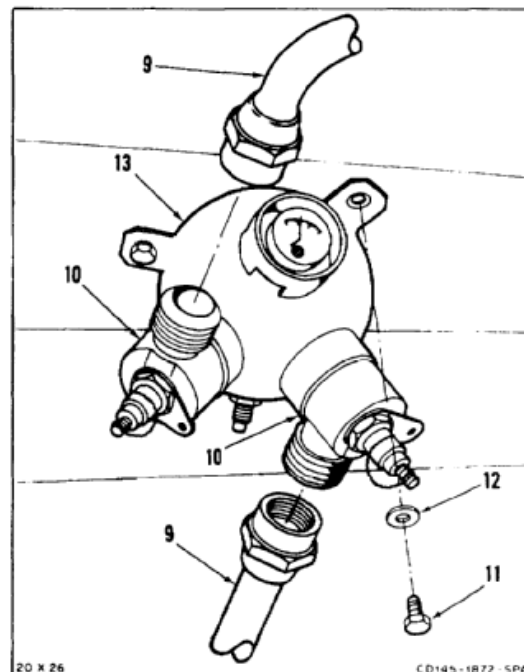

Task 12-25 deleted.

END OF TASK

## INITIAL SETUP

**Applicable Configurations:**

All

**Tools:**

Technical Inspection Tool Kit, NSN 5180-00-323-5114  
Dial Indicating Scale, 0 to 10 Pounds

**Materials:**

Lockwire (E231)

**Personnel Required:**

Inspector

**References:**

TM 55-1520-240-23P

**Equipment Condition:**

Off Helicopter Task

**General Safety Instructions:****WARNING**

When not mounted in helicopter, fire extinguishers (bottles) can become dangerous missiles if discharged. Do not detonate, discharge, or abuse fire extinguishers. Injury to personnel can result. Remove cartridges (squibs) when extinguishers are removed for storage.

**WARNING**

Whenever fire extinguisher cartridges are not installed, the positive terminal and ground terminal must be shunted to prevent firing from stray voltage.

**INSPECT EXTINGUISHER**

1. If not already done, connect shunt wire (1) between positive electrical terminal (2) and ground terminal (3). Use lockwire (E231).
2. Check extinguisher (4) for damage. There shall be no nicks, cracks, cuts, corrosion, chafing, or scoring.
3. Inspect extinguisher (4) for scratches. There shall be no scratches deeper than **0.004 inch**.
4. Inspect extinguisher (4) for dents. There shall be no dents deeper than **1/16 inch per inch** of dent diameter.
5. Check decal (5) and helicopter DA Form 2408-18 for servicing dates of extinguisher (4). If this information is not recorded, weigh extinguisher (4). If extinguisher weighs **6.25 pounds** or more, install a new decal. If extinguisher weighs less than **6.25 pounds**, return it for servicing. Install a new extinguisher.
6. Weigh extinguisher (4) without caps or protective plugs. Compare weight to weight marked on decal (5). Difference shall be less than **4 ounces**.

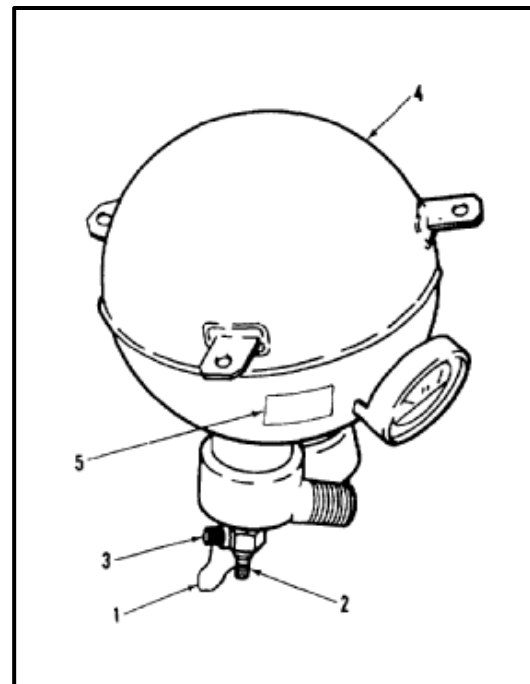

**INSPECT GAGE**

7. Check gage (6). Gage shall not be broken or damaged.
8. Read gage (6). Pressure reading shall be within limits shown below.

<b>Temperature</b>	<b>Minimum Pressure</b>
-40°C (-40°F)	292 psi
-29°C (-20°F)	320 psi
-18°C (0°F)	355 psi
-7°C (19°F)	396 psi
4°C (39°F)	449 psi
15°C (59°F)	518 psi
27°C (81°F)	593 psi
38°C (100°F)	691 psi
52°C (126°F)	785 psi

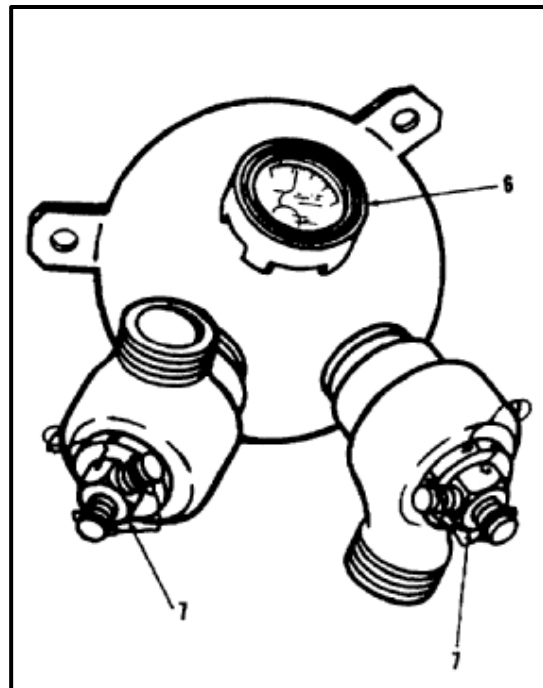

**INSPECT CARTRIDGE**

9. Check retirement date of both cartridges (7). Refer to DA Form 2408-18. Cartridges shall not be out of date.

**FOLLOW-ON MAINTENANCE:**

None

END OF TASK



## INITIAL SETUP

**Applicable Configurations:**

All

**Tools:**

Technical Inspection Tool Kit, NSN 5180-00-323-5114  
Dial Indicating Scale, 0 to 10 Pounds

**Materials:**

Lockwire (E231)

**Personnel Required:**

Inspector

**References:**

TM 55-1520-240-23P

**Equipment Condition:**

Off Helicopter Task

**General Safety Instructions:****WARNING**

When not mounted in helicopter, fire extinguishers (bottles) can become dangerous missiles if discharged. Do not detonate, discharge, or abuse fire extinguishers. Injury to personnel can result. Remove cartridges (squibs) when extinguishers are removed for storage.

**WARNING**

Whenever fire extinguisher cartridges are not installed, the positive terminal must be shunted to the cartridge body to prevent accidental firing and discharge from stray voltages.

**INSPECT EXTINGUISHER**

1. If not already done, connect shunt wire (1) on both cartridges between positive electrical terminal (2) and ground washer (3). Use lockwire (E231).
2. Secure wire (1) with washer (4), screw (5), and nut (6).
3. Check extinguisher (7) for damage. There shall be no bulges, dents, cracks, or corrosion.
4. Inspect extinguisher (7) for pits, cuts, or gouges. There shall be no damage deeper than **0.005 inch**.
5. Check decal (8) and helicopter DA Form 2408-18 for servicing dates of extinguisher (7). If this information is not recorded, weigh extinguisher (7). If extinguisher weighs **6.25 pounds** or more, install a new decal and record the weight. If it weighs less than **6.25 pounds**, return the bottle for servicing. Install a new bottle.
6. Weigh extinguisher (7) without caps or protective plugs. Compare weight to weight marked on decal (8). Difference shall be less than **4 ounces**.

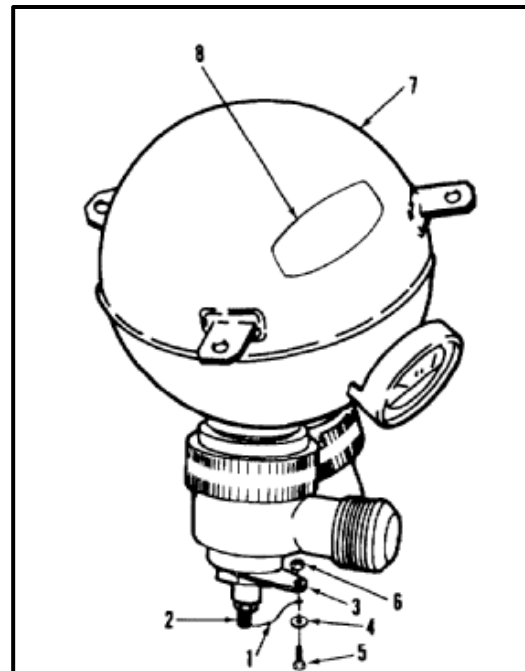

**INSPECT GAGE**

- 7. Check gage (9). Gage shall not be broken or damaged.
- 8. Read gage (9). Pressure reading shall be within limits shown below.

<b>Temperature</b>	<b>Minimum Pressure</b>
-40°C (-40°F)	292 psi
-29°C (-20°F)	320 psi
-18°C (0°F)	355 psi
-7°C (19°F)	396 psi
4°C (39°F)	449 psi
15°C (59°F)	518 psi
27°C (81°F)	593 psi
38°C (100°F)	691 psi
52°C (126°F)	785 psi

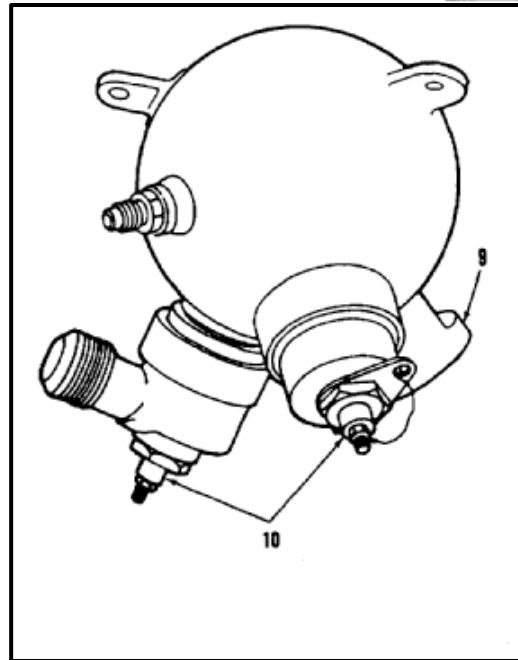

**INSPECT CARTRIDGE**

- 9. Check retirement date of both cartridges (10). Refer to DA Form 2408-18. Cartridges shall not be out of date.

**FOLLOW-ON MAINTENANCE:**

None

END OF TASK

INITIAL SETUP

**Applicable Configurations:**

All

**Tools:**

Aircraft Mechanic's Tool Kit, NSN 5180-00-323-4692  
 Open End Wrench, 1-1/4 Inch  
 Workstand

**Materials:**

Paper Tags (E264)  
 Lockwire (E231)

**Personnel Required**

Medium Helicopter Repairer

**Equipment Condition:**

Battery Disconnected (Task 1-39)  
 Electrical Power Off  
 Helicopter Grounded (Task 1-29)  
 FIRE EXT AGENT Switch in Center (OFF) Position  
 Both Fire Pull Handles Pushed In

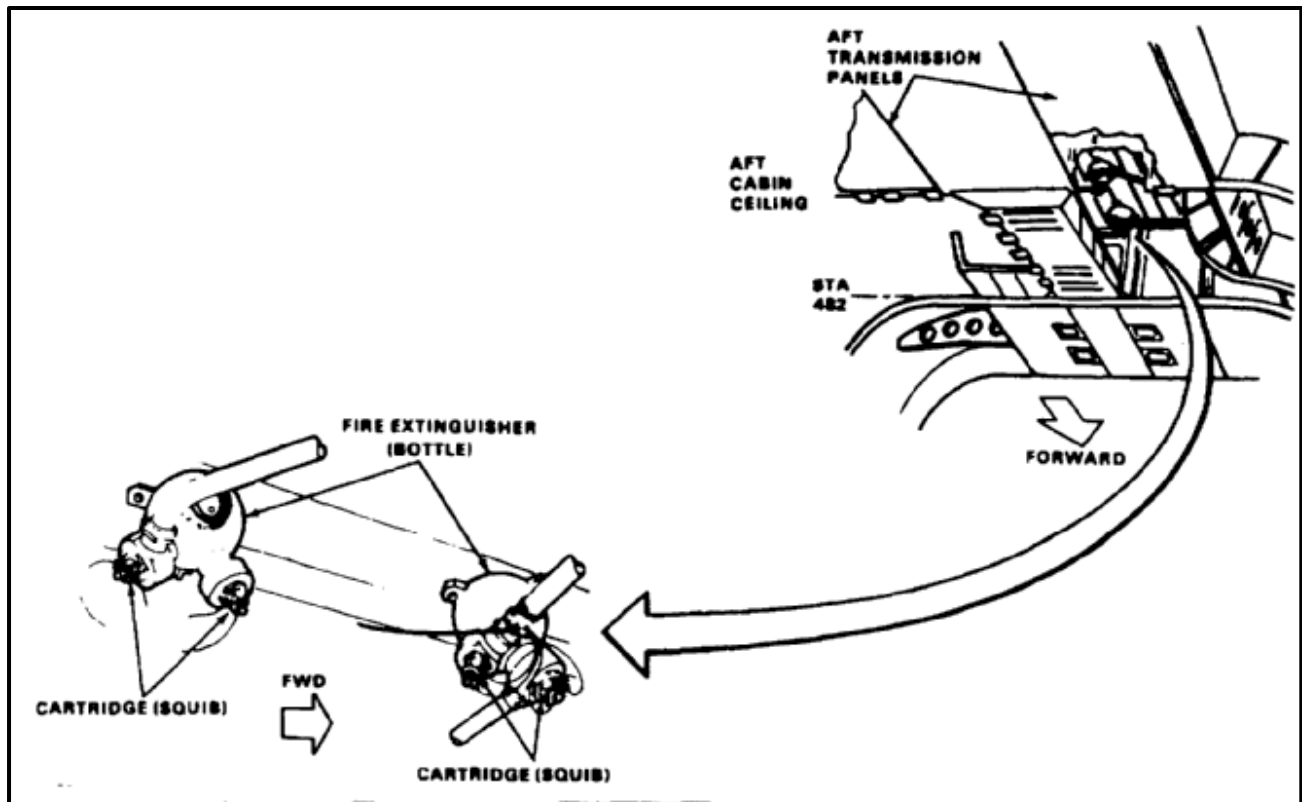

**NOTE**

There are two cartridges (squibs) on each fire extinguisher (bottle). Both are removed in same way.

1. Remove nut (1) and disconnect wire (2) from electric terminal (3) of cartridge (4). Tag wire.
2. Remove nut (1) and disconnect wire (5) from ground terminal (6) of cartridge (4). Tag wire.
3. Connect shunt wire (7) between electric terminal (3) and ground terminal (6). Use lockwire (E231).
4. Remove lockwire from cartridge (4) and housing (8).

**WARNING**

Do not allow housing to turn. If housing loosens, fire extinguisher can discharge and can cause personal injury.

5. Use wrench (9) on housing (8) to keep housing from turning.

**WARNING**

Cartridge is an explosive device and is dangerous to personnel. Be sure the electrical terminal is shunted to the ground terminal before the cartridge is removed. Place the cartridge in a protective container.

6. Remove cartridge (4) and packing (10).

**FOLLOW-ON MAINTENANCE:**

None

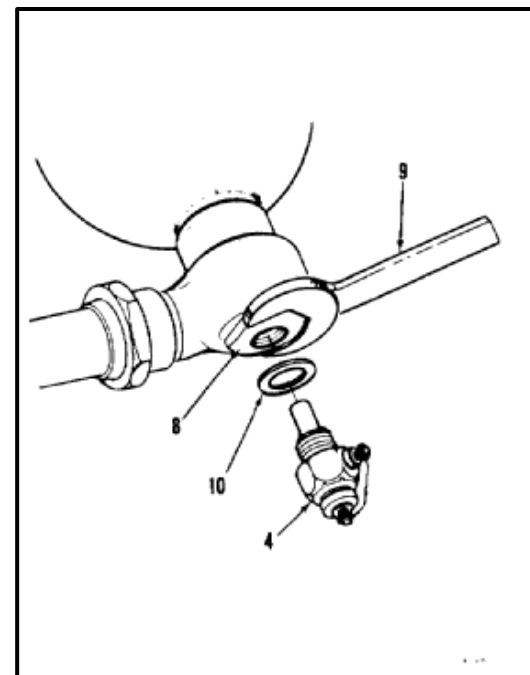
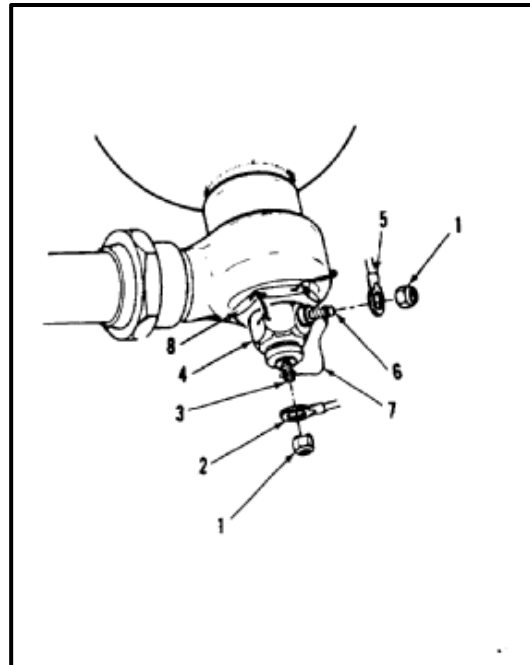

END OF TASK

INITIAL SETUP

**Applicable Configurations:**

All

**Tools:**

Aircraft Mechanic's Tool Kit, NSN 5180-00-323-4692  
 Open End Wrench, 1 Inch  
 Workstand

**Materials:**

Paper Tags (E264)  
 Lockwire (E231)

**Personnel Required:**

Medium Helicopter Repairer

**Equipment Condition:**

Battery Disconnected (Task 1-39)  
 Helicopter Grounded (Task 1-29)  
 Electrical Power Off  
 FIRE EXT AGENT Switch in Center (OFF) Position  
 Both Fire Pull Handles pushed in

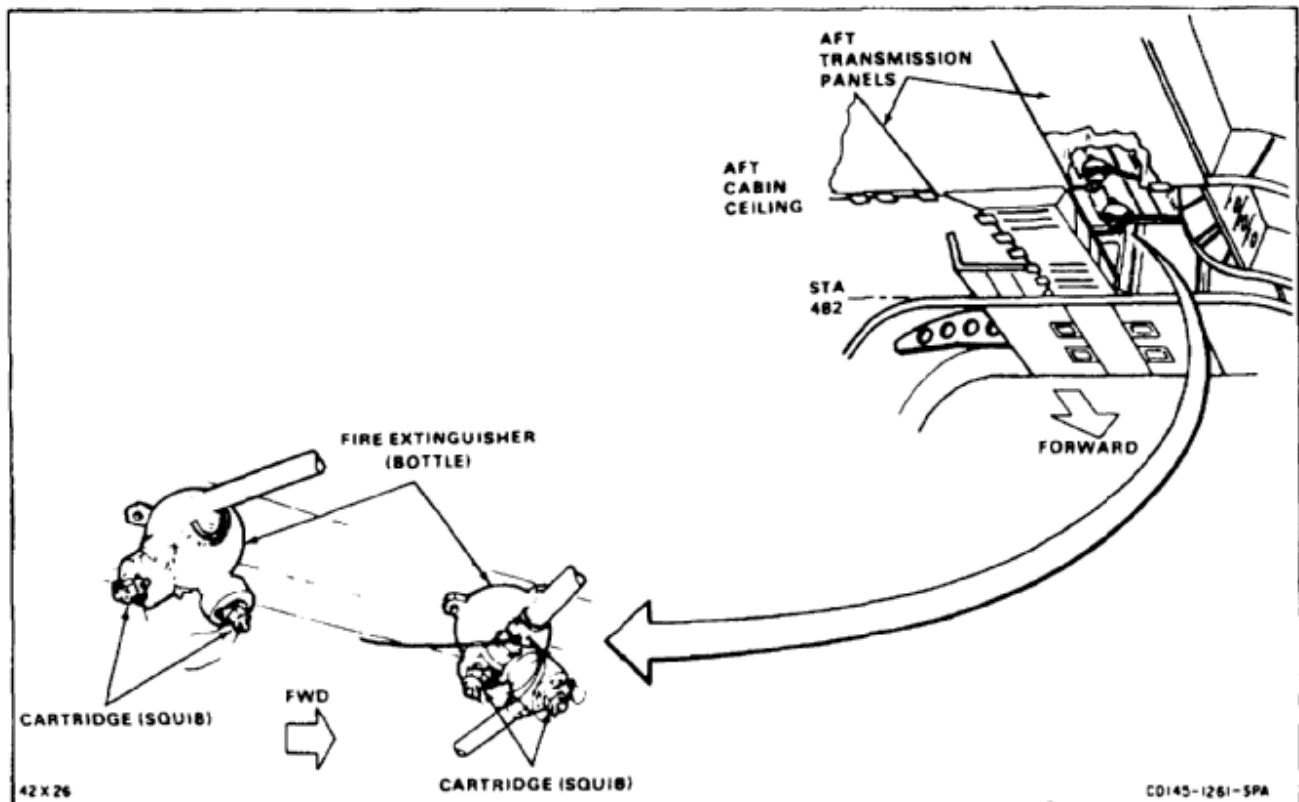

**NOTE**

There are two cartridges (squibs) on each fire extinguisher (bottle). Both are removed in same way.

1. Remove screw (1), washer (2), two nuts (3), and disconnect wire (4) from ground washer (5). Tag wire.
2. Remove nut (3) and disconnect wire (6) from terminal (7). Tag wire.
3. Connect piece of shunt wire (7) between terminal (8) and body of cartridge (9). Use wire (E231).

**WARNING**

A cartridge is an explosive device and is dangerous to personnel. Be sure the electrical terminal is shunted to the cartridge case before the cartridge is removed. Place the cartridge in a protective container.

4. Remove cartridge (9) and ground washer (5).

**FOLLOW-ON MAINTENANCE:**

None

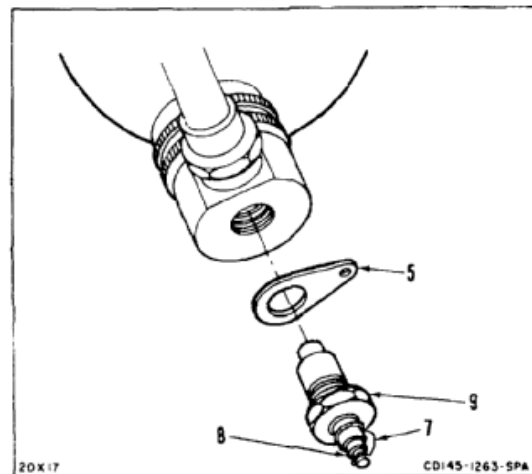
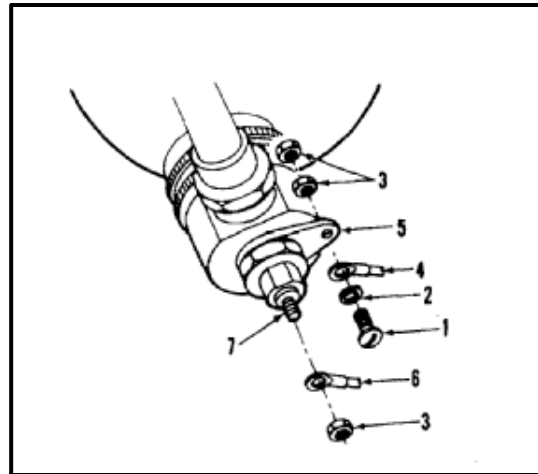

END OF TASK

INITIAL SETUP

**Applicable Configurations:**

All

**Tools:**

Aircraft Mechanic's Tool Kit, NSN 5180-00-323-4692  
 Open End Wrench, 1-1/4 Inch  
 Torque Wrench, 100 to 750 Inch-Pounds  
 Workstand

**Materials:**

Grease (E190)  
 Lockwire (E231)

**Parts:**

Packing

**Personnel Required:**

Medium Helicopter Repairer  
 Inspector

**References:**

TM 55-1520-240-23P

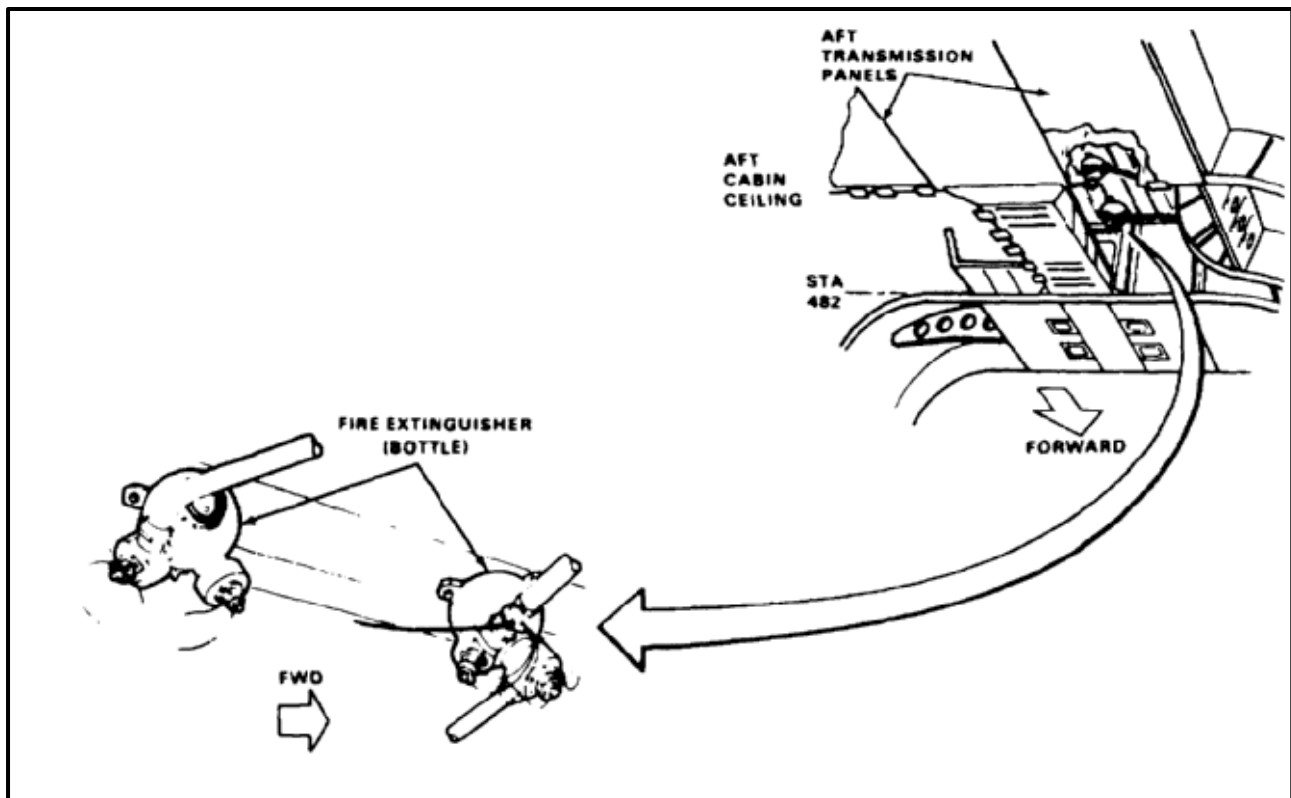

**WARNING**

Do not allow housing to turn. If housing loosens, fire extinguisher can discharge and cause personnel injury.

**NOTE**

There are two cartridges (squibs) on each fire extinguisher (bottle). Both are installed in same way.

1. Install packing (1) on cartridge (2).
2. Apply grease (E190) to cartridge thread (3).
3. Use wrench (4) on the flats of housing (5) to keep it from turning.
4. Install cartridge (2) in housing (5).
5. Torque cartridge (2) to **175 inch-pounds**.
6. Lockwire cartridge (2) per directions on decal (6). Use lockwire (E231).

**CAUTION**

Be sure to remove shunt, otherwise fire bottle won't discharge when it is needed.

7. Remove shunt wire (7) from electric terminal (8) and ground terminal (9).
8. Connect wire (10) and install nut (11) on ground terminal (9). Torque nut to **10 inch-pounds**. Remove tag from wire.
9. Connect wire (12) and install nut (11) on electric terminal (8). Remove tag from wire.

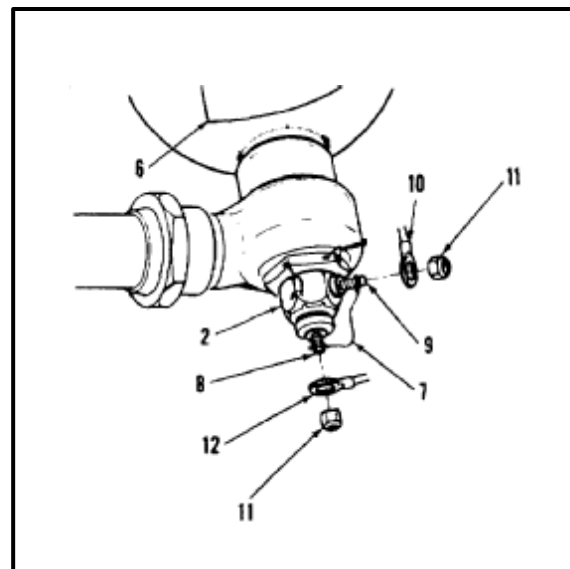
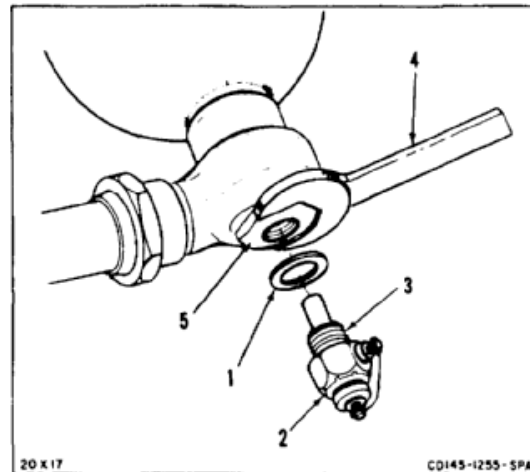
**INSPECT****FOLLOW-ON MAINTENANCE:**

Perform operational check (TM 55-1520-240-T).

END OF TASK

12-72



INITIAL SETUP

**Applicable Configurations:**

All

**Tools:**

- Aircraft Mechanic's Tool Kit, NSN 5180-00-323-4692
- Torque Wrench, 100 to 750 Inch-Pounds
- Open End Wrench, 1 Inch
- Workstand

**Materials:**

Grease (E190)

**Personnel Required:**

- Medium Helicopter Repairer
- Inspector

**References:**

TM 55-1520-240-23P

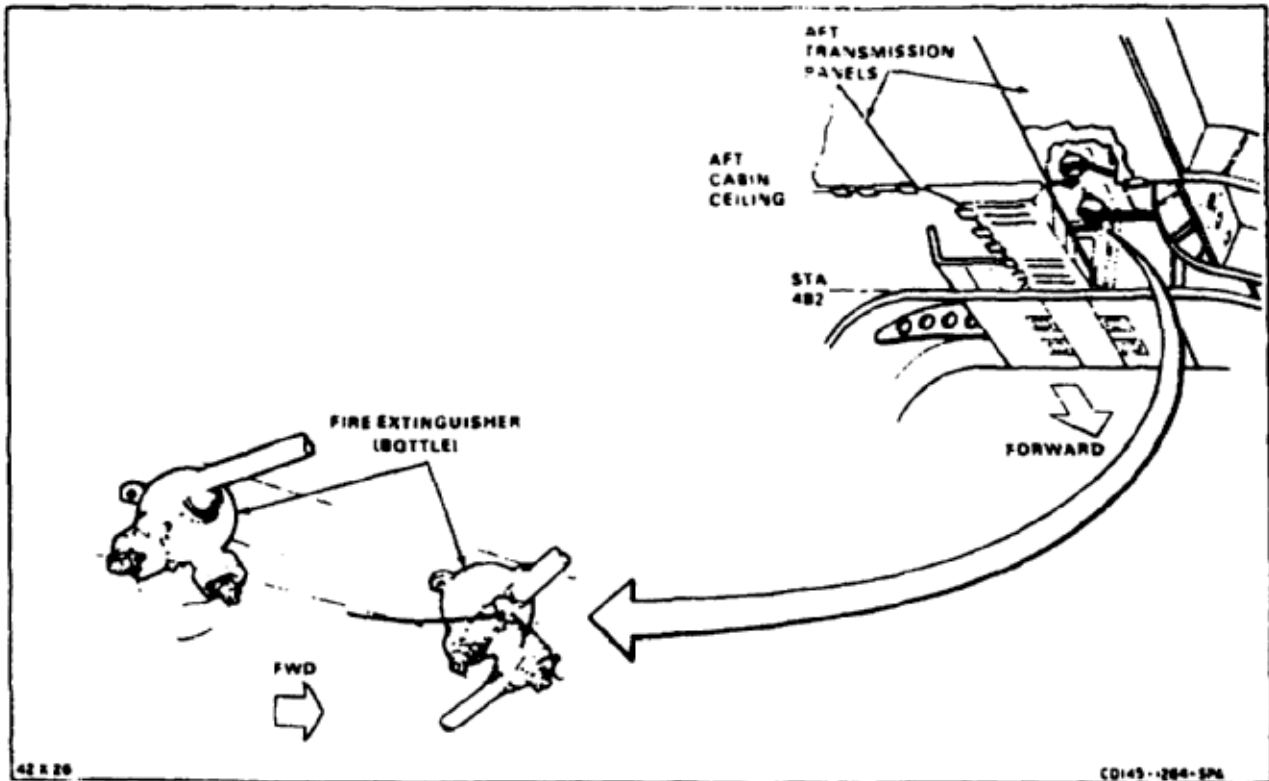

42 X 20

CD145-1284-526

**NOTE**

There are two cartridges (squibs) on each fire extinguisher (bottle). Both are installed in same way.

1. Install ground washer (1) on cartridge (2).
2. Apply grease (E190) to cartridge thread (3).
3. Install cartridge (2) in housing (4).
4. Torque cartridge (2) to **175 inch-pounds**.



Be sure to remove shunt. Otherwise, fire bottle won't discharge when it is needed.

5. Remove wire shunt (5) from electrical terminal (6) and body of cartridge (2).
6. Install wire (7), washer (8), screw (9), and two nuts (10) on ground washer (1). Remove tag from wire.
7. Install wire (11) and nut (10) on terminal (6). Remove tag from wire.

**INSPECT****FOLLOW-ON MAINTENANCE:**

Perform operational check (TM 55-1520-240-T).

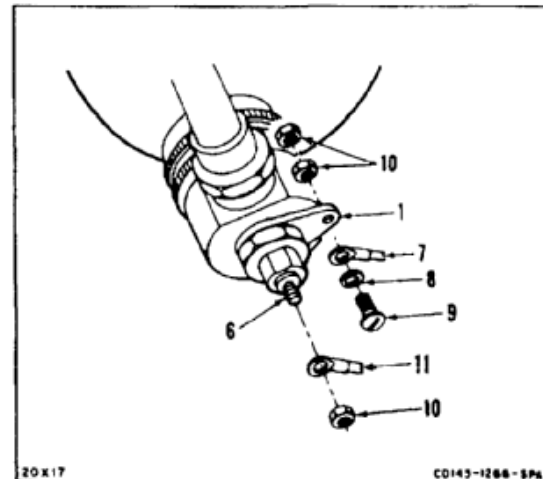
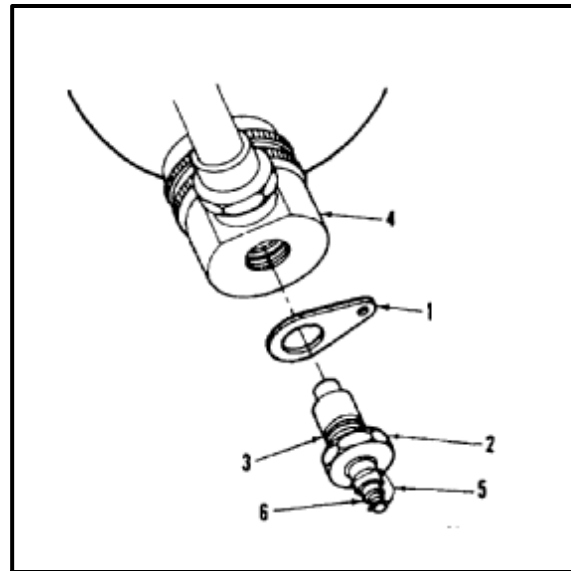

END OF TASK

INITIAL SETUP

**Applicable Configurations:**

All

**Tools:**

Aircraft Mechanic's Tool Kit, NSN 51 80-00-323-4692  
 Open End Wrench, 1-1/2 Inch  
 Workstand

**Materials:**

None

**Personnel Required:**

Medium Helicopter Repairer  
 Inspector

**References:**

TM 55-1520-240-23P  
 TM 55-1520-240-T

**General Safety Instructions:**

**WARNING**

When not mounted in helicopter, fire extinguishers (bottles) can become dangerous missiles if discharged. Do not detonate, discharge, or abuse fire extinguishers. Injury to personnel can result. Remove cartridges (squibs) when extinguishers are removed for storage.

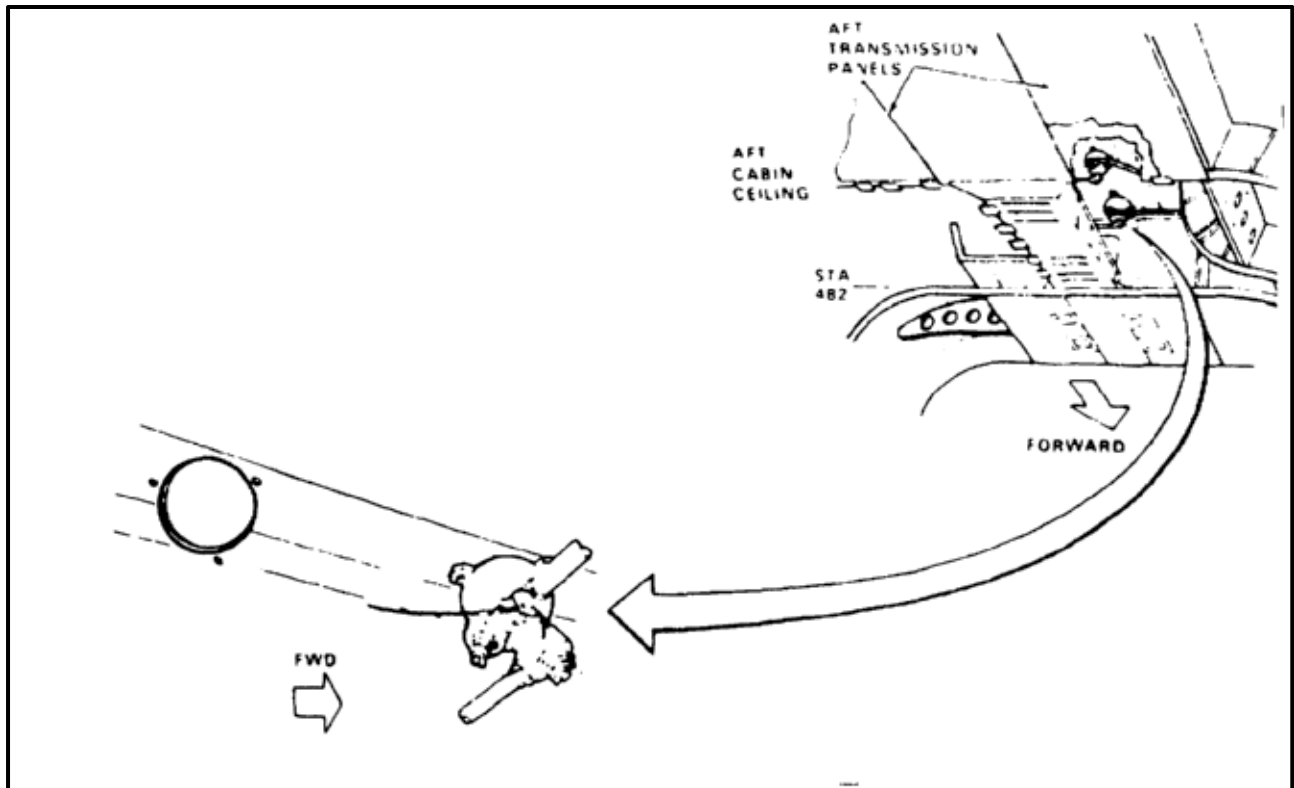

**NOTE**

There are two engine fire extinguishers inside helicopter in aft cabin ceiling. Installation procedure is same for both.

**INSTALL EXTINGUISHER**

1. Remove protective caps from valves (1).
2. Remove protective plugs or caps from tubes (2).
3. Position extinguisher (3) in cabin ceiling (4).
4. Install three washers (5) and bolts (6). Do not tighten.
5. Connect tubes (2) to both valves (1). Do not tighten.
6. Tighten three bolts (6).
7. Tighten two tubes (2).

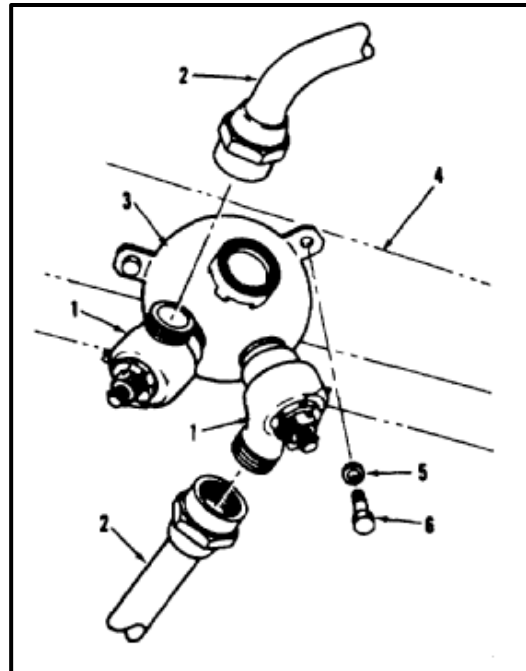

**CONNECT WIRING, FORWARD CARTRIDGE****CAUTION**

Be sure to remove shunt. Otherwise, fire bottle won't discharge when it is needed.

8. Remove wire between electrical terminal (7) and ground terminal (8) of forward cartridge (9) only.
9. Perform Operational Check (TM 55-1520-240-T).
10. Connect electrical wire (10) to terminal (7) and install nut (11). Connect ground wire (12) to terminal (8) and install nut (11). Remove tags from wires.

**CONNECT WIRING, AFT CARTRIDGE****CAUTION**

Be sure to remove shunt. Otherwise, fire bottle won't discharge when it is needed.

11. Remove wire between electrical terminal (7) and ground terminal (8) of aft (13).
- 11.1. Perform Operational Check (TM 55-1520-240-T).
12. Connect electrical wire (10) to terminal (7) and install nut (11). Connect ground wire (12) to terminal (8) and install nut (11). Remove tags.

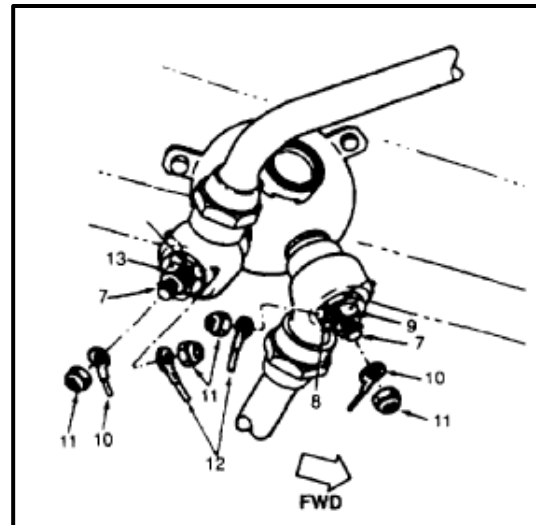
**INSPECT**

END OF TASK

INITIAL SETUP

**Applicable Configurations:**

All

**Tools:**

Aircraft Mechanic's Tool Kit, NSN 5180-00-323-4692  
Open End Wrench, 1-1/2 Inch

**Materials:**

None

**Personnel Required:**

Medium Helicopter Repairer (2)  
Inspector

**References:**

TM 55-1520-240-23P  
TM 55-1520-240-T

**General Safety Instructions:**

**WARNING**

When not mounted in helicopter, fire extinguisher (bottles) can become dangerous missiles if discharged. Do not detonate, discharge, or abuse fire extinguishers. Injury to personnel can result. Remove cartridges (squibs) when extinguishers are removed for storage.

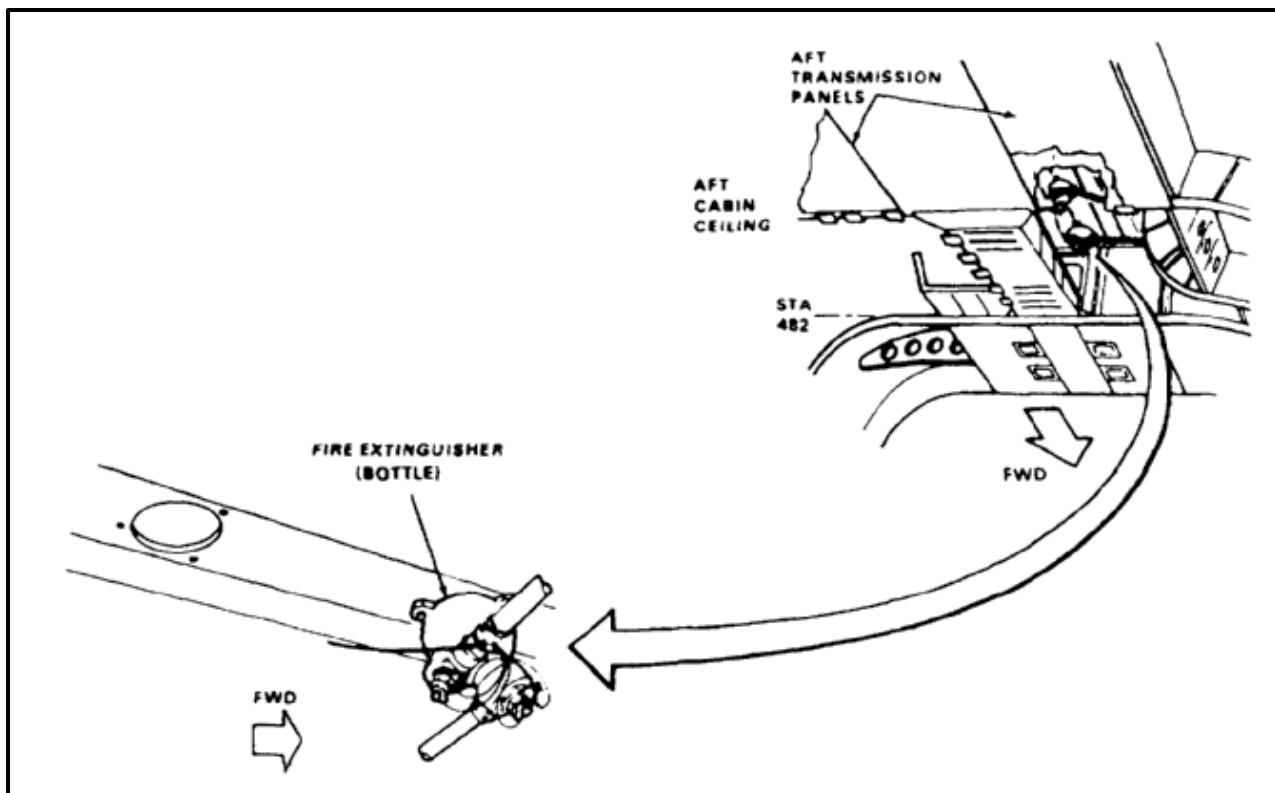

**NOTE**

There are two engine fire extinguishers in aft cabin ceiling. Installation procedures is same for both.

**INSTALL BOTTLE**

1. Remove caps from valves (1).
2. Remove plugs or caps from tubes (2).
3. Position extinguisher (3) in cabin ceiling (4).
4. Install three washers (5) and bolts (6). Do not tighten bolts.
5. Connect tubes (2) to both valves (1). Do not tighten tubes.
6. Tighten three bolts (6).
7. Tighten two tubes (2).

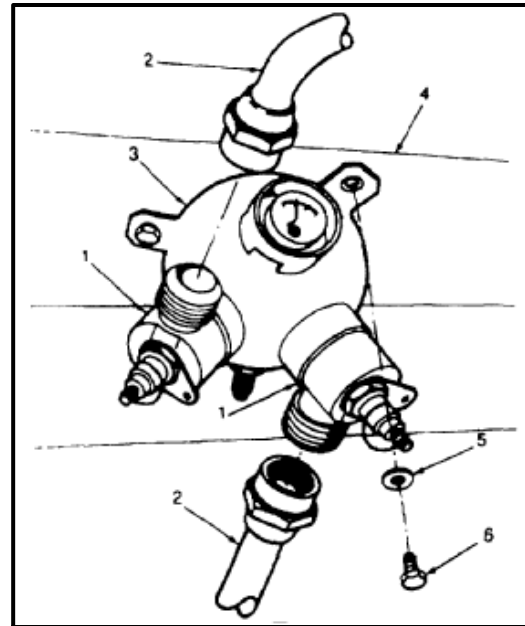
**CONNECT WIRING, FORWARD CARTRIDGE**

8. Remove wire between terminal (7) and body of forward cartridge (8) only.
- 8.1. Perform Operational Check (TM 55-1520-240-T).
9. Connect electrical wire (9) to terminal (7) and install nut (10).
10. Connect ground wire (11) to washer (12) and install screw (13), washer (14), and two nuts (10). Remove tags.

**CONNECT WIRING, AFT CARTRIDGE**

11. Remove wire between terminal (7) and body of aft cartridge (15).
- 11.1. Perform Operational Check (TM 55-1520-240-T).
12. Connect electrical wire (9) to terminal (7) and install nut (10).
13. Connect ground wire (11) to washer (12) and install screw (13), washer (14), and two nuts (10). Remove tags.

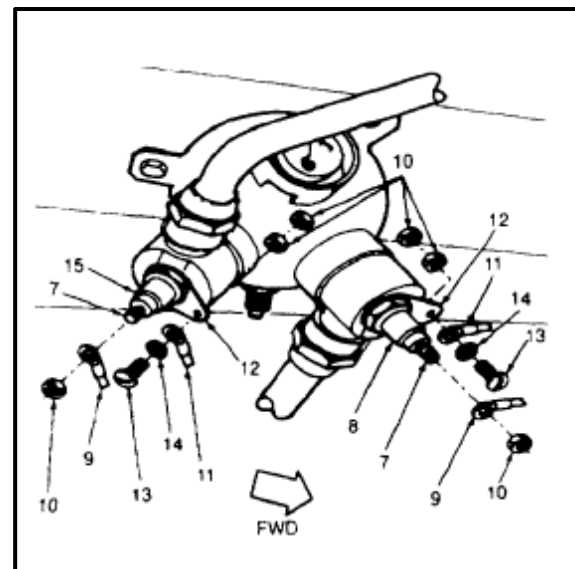
**INSPECT****FOLLOW-ON MAINTENANCE:**

Perform Operational Check (TM 55-1520-240-T).

END OF TASK





**SECTION V**  
**WINDSHIELD WIPER SYSTEM DESCRIPTION AND OPERATION**

The windshield wiper system consists of a motor, a five-position switch, and resistors in the overhead panel, two wiper arms and blades, drive shafts, and actuators.

The **28 vdc** electric motor is powered by the No. 2. DC bus thru the WSHLD WIPER circuit breaker on the No. 2 PDP. Mounted above center windshield behind the overhead panel, the motor provides power to drive the wipers thru flexible drive shafts connected from the motor to the actuators.

The actuators convert the rotary action of the motor to a back and forth motion to move the wipers. The actuators are located inside the cockpit above the windshields.

The five position switch controls the speed at which the wipers will move, (SLOW, MED, and FAST) and it also has an OFF and PARK setting. If OFF is selected while the wipers are in motion, the wipers will stop at their current position. If PARK is selected, they will return to the Stowed/Parked position against the inside windshield frame. Two wiper arms maintain a constant pressure to hold the blades against the windshields, as long as the wind deflecting shield on the blade assembly is installed with the upper/higher edge towards the inside frame of the windshield.

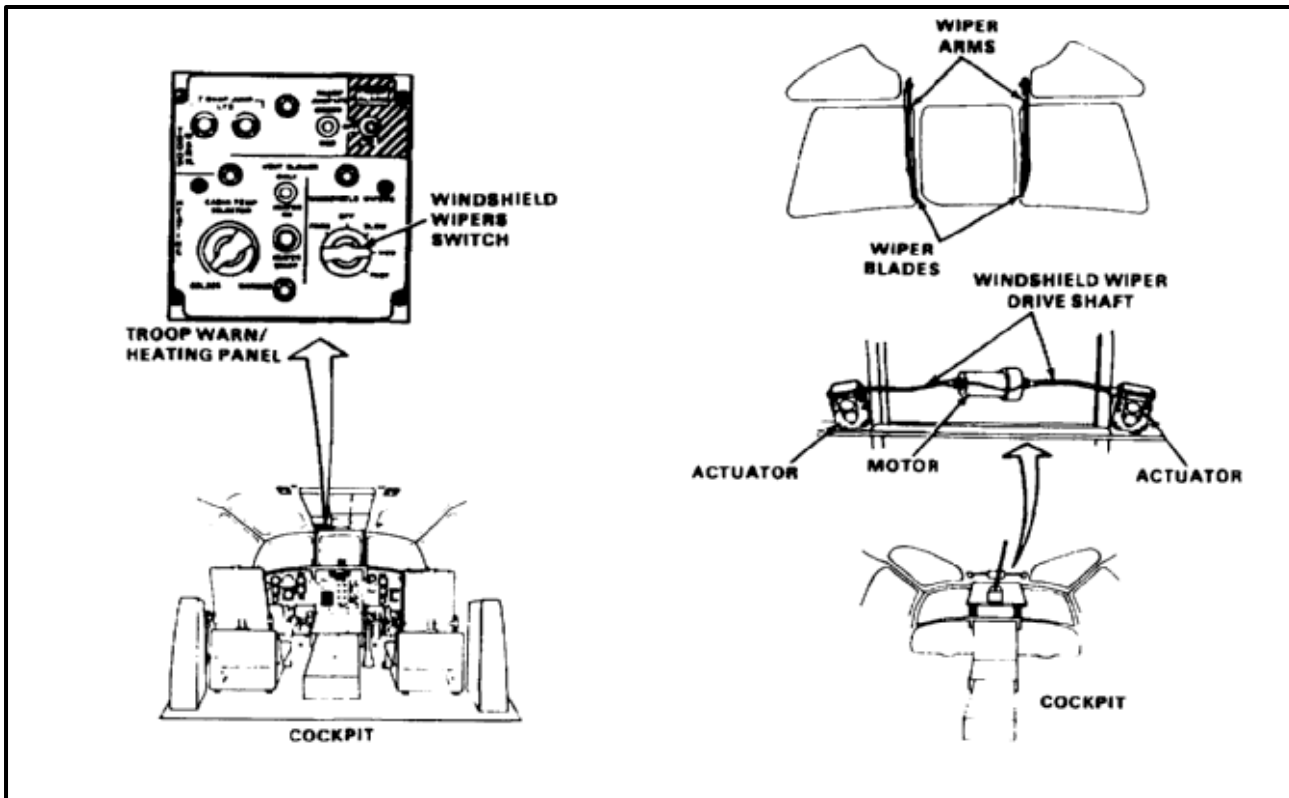

END OF TASK

**SECTION VI**  
**WINDSHIELD WIPER SYSTEM**

## INITIAL SETUP

**Applicable Configurations:**

All

**Tools:**

Aircraft Mechanic's Tool Kit, NSN 5180-00-323-4692  
Workstand  
Cotter Pin, 1/8 Inch Diameter

**Materials:**

Masking Tape (E388)  
Wrapping Paper (E263)

**Personnel Required:**

Medium Helicopter Repairer

**Equipment Condition:**

Battery Disconnected (Task 1-39)  
Electrical Power Off



Windshields can be damaged while wipers are being worked on. Failure to protect it can result in damage to windshield.

**NOTE**

There are two windshield wipers.  
Removal procedure is same for both.  
Right wiper is shown here.

1. Lift wiper arm (1) and insert cotter pin (2) in hole (3) in arm.
2. Cover windshield (4) with paper (E263). Use tape (E388) to hold paper on windshield.
3. Remove cotter pin (5), nut (6), and washer (7).
4. Remove small nut (8).
5. Remove wiper blade (9) and disk (10) from wiper arm (1).

**FOLLOW-ON MAINTENANCE:**

None

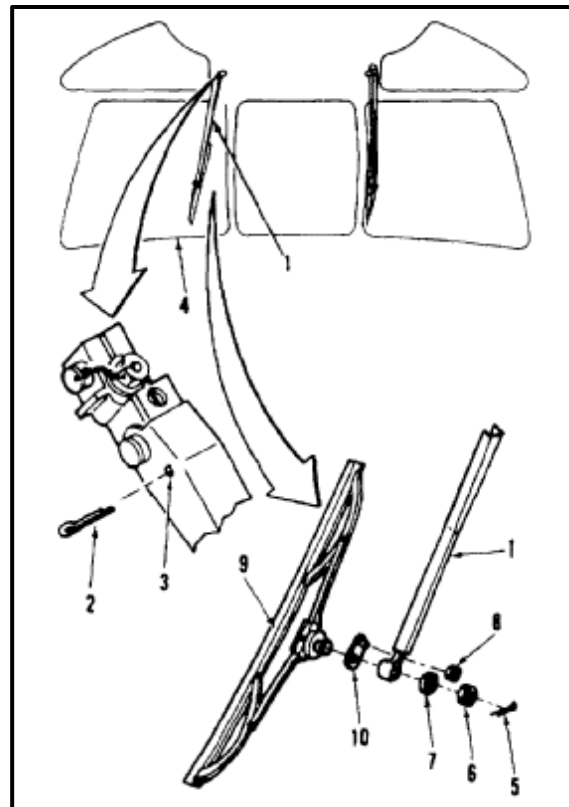
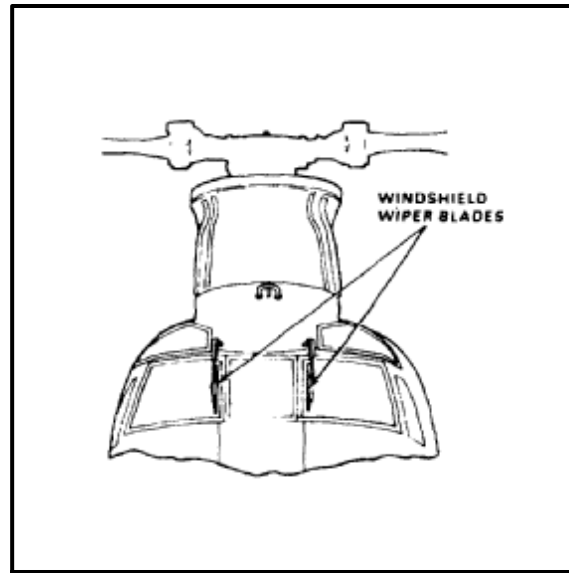

END OF TASK

INITIAL SETUP

**Applicable Configurations:**

All

**Tools:**

Aircraft Mechanic's Tool Kit, NSN 5180-00-323-4692  
Workstand

**Materials:**

None

**Parts:**

Cotter Pin

**Personnel Required:**

CH-47 Helicopter Repairer  
Inspector

**References:**

TM 55-1520-240-23P

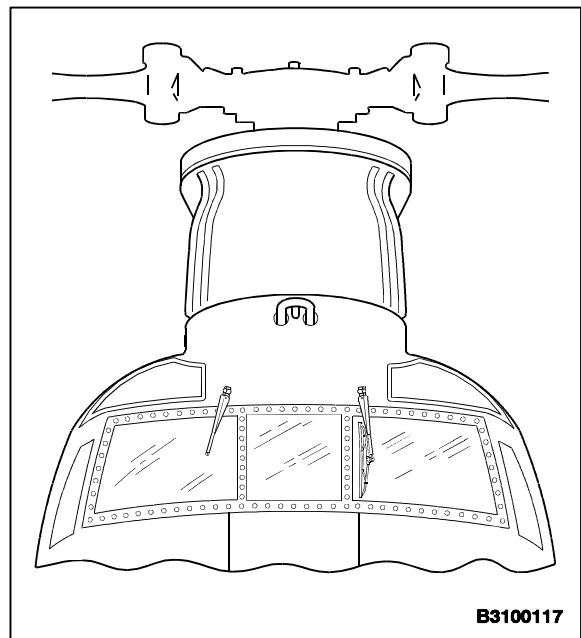

Deleted.

**NOTE**

Deleted.

There are two windshield wipers.  
Installation procedure is same for  
both. Right wiper is shown here.

1. Check disk (1). There shall be no stripped grooves.
2. Install disk (1) on end of arm (2).
3. Install small nut (3).
4. Check wiper blade (4). There shall be no cracked, torn, or loose rubber.
5. Insert stud (5) of wiper blade (4) through disk (1) and arm (2).
6. Align wiper blade (4) with arm (2). Be sure air scoop (6) is facing outboard.
7. Install washer (7), nut (8), and cotter pin (9).
8. Remove protective paper and tape from windshield (10).
9. Remove cotter pin (11) from hole (12).
10. Lower arm (2) so blade (4) is on windshield (10).

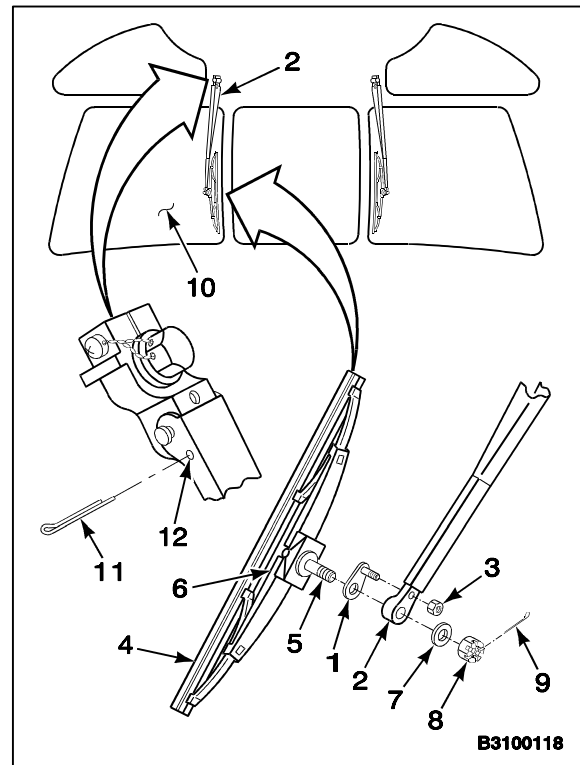
**INSPECT****FOLLOW-ON MAINTENANCE:**

- Adjust wiper arm pressure (Task 12-37).

END OF TASK

INITIAL SETUP

**Applicable Configurations:**

All

**Tools:**

- Aircraft Mechanic's Tool Kit, NSN 5180-00-323-4692
- Dial Indicating Scale, 0 to 10 Pound
- Wrench (T192)
- Workstand

**Materials:**

None

**Personnel Required:**

CH-47 Helicopter Repairer

**References:**

TM 55-1520-240-T

**Equipment Condition:**

Windshield Wipers in Parked Position  
(TM 55-1520-240-T)

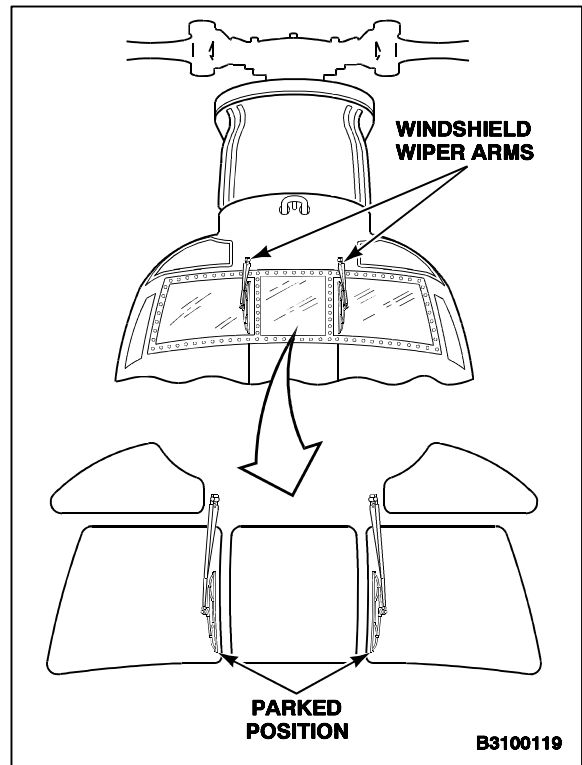

**NOTE**

Deleted.

1. Hook dial indicating scale (1) to wiper arm (2) at wiper attach point (3).
2. Pull scale until wiper blade (4) just lifts from windshield (5).
3. Read scale (1). If scale reads **8 pounds** or more, go to step 5. If scale reads less than **8 pounds**, go to step 4.
4. Increase arm pressure by turning key (6) counterclockwise. Use wrench (T192). Turn key and pull scale (1) until scale reads more than **8 pounds**.
5. Remove scale (1).

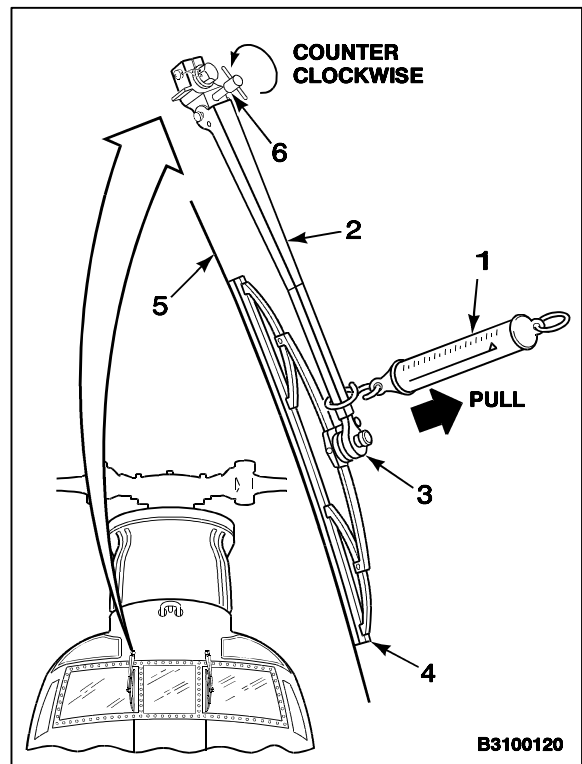

6. Operate wipers (4) on wet windshield (5) for **1 minute** (TM 55-1520-240-T).
7. Repeat steps 1 thru 6 until scale reads **8 pounds** or more twice in a row.

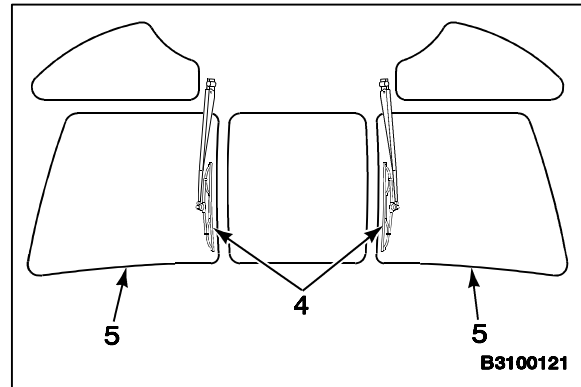
**FOLLOW-ON MAINTENANCE:**

None

Task 12-38, pages 12-89 and 12-90 have been deleted.

END OF TASK

12-88 Change 1



## INITIAL SETUP

**Applicable Configurations:**

All

**Tools:**

Aircraft Mechanic's Tool Kit, NSN 51 80-00-323-4692  
 Workstand  
 Cotter Pin, 1/8 Inch

**Materials:**

Masking Tape (E388)  
 Wrapping Paper (E263)

**Personnel Required:**

Medium Helicopter Repairer

**Equipment Condition:**

Battery Disconnected (Task 1-39)  
 Electrical Power Off  
 Windshield Wipers in Parked Position (TM  
 55-1520-240T)

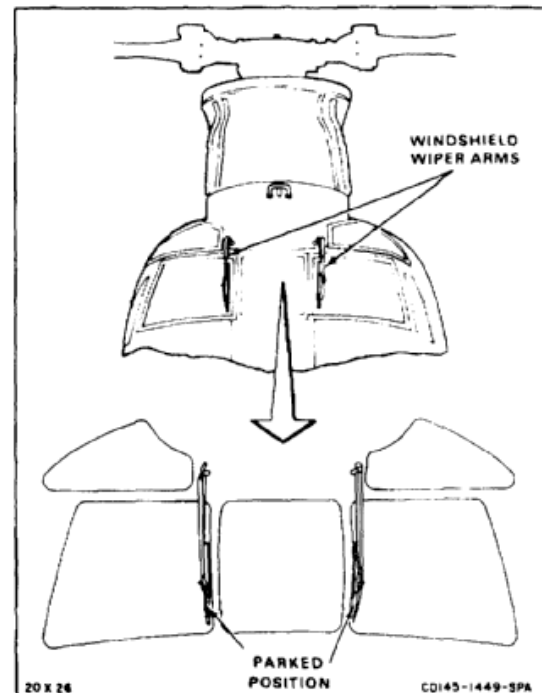

Windshields can be damaged while wipers are being worked on. Failure to protect it can result in damage to windshield.

**NOTE**

Wipers are at inboard edge of windshield when wiper switch is at PARK.

There are two windshield wiper arms. Removal procedure is same for both. Right wiper is shown here.

1. Lift wiper arm (1) and insert cotter pin (2) in hole (3).
2. Cover windshield (4) with paper (E263). Use tape (E388) to hold paper on windshield.
3. Remove lockwire from screw (5) and bolt (6).
4. Loosen screw (5).
5. Remove bolt (6) and washer (7).
6. Remove wiper arm (1) and sleeve (8).

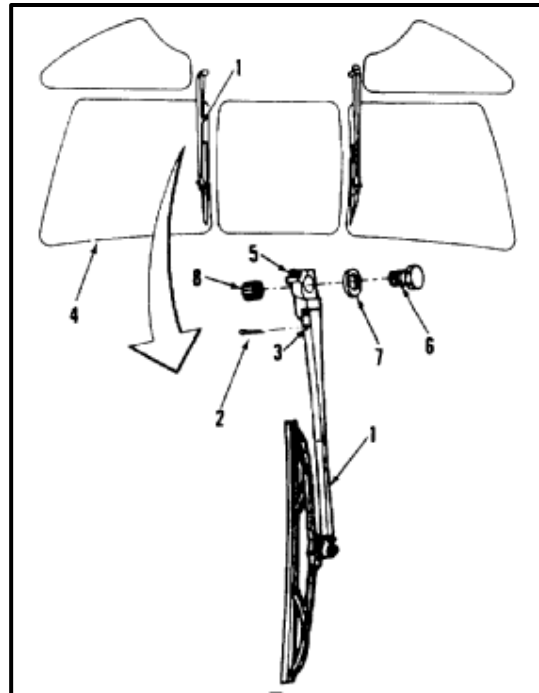
**FOLLOW-ON MAINTENANCE:**

None

END OF TASK

**INITIAL SETUP****Applicable Configurations:**

All

**Tools:**

Aircraft Mechanic's Tool Kit, NSN 5180-00-323-4692

**Materials:**

None

**Personnel Required:**

CH-47 Helicopter Repairer

**References:**

TM 55-1520-240-23P

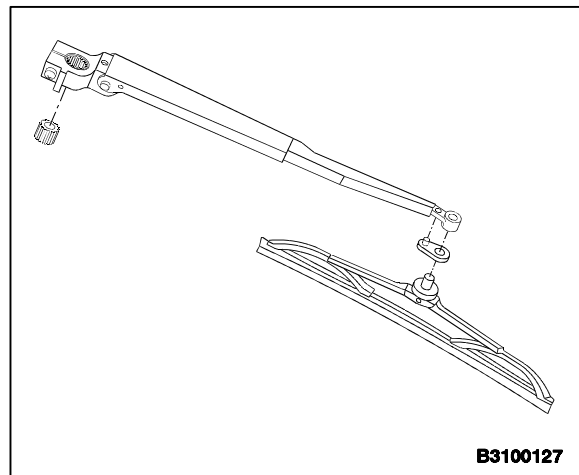
**Equipment Condition:**Off Helicopter Task  
Wiper Blade Removed (Task 12-35)**WIPER ARM**

1. Check inside and outside grooves of adjustment sleeves (1). There shall be no stripped grooves.
2. Check grooves in hub (2) at end of wiper arm (3). There shall be no stripped grooves.

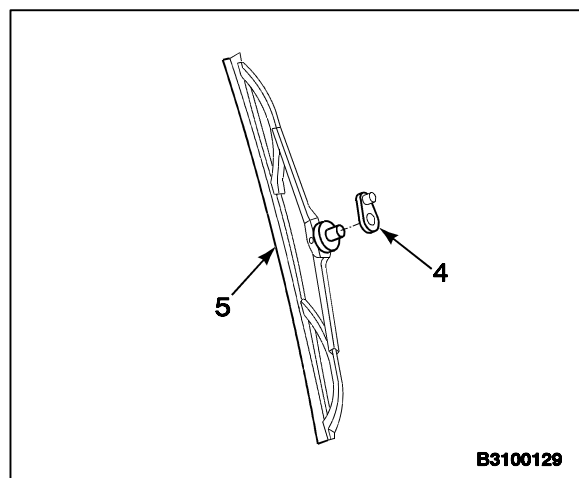
**WIPER BLADE**

3. Check grooves of disk (4). There shall be no stripped grooves.
4. Check rubber of wiper blade (5). There shall be no cracks, tears, or looseness.

**FOLLOW-ON MAINTENANCE:**

None

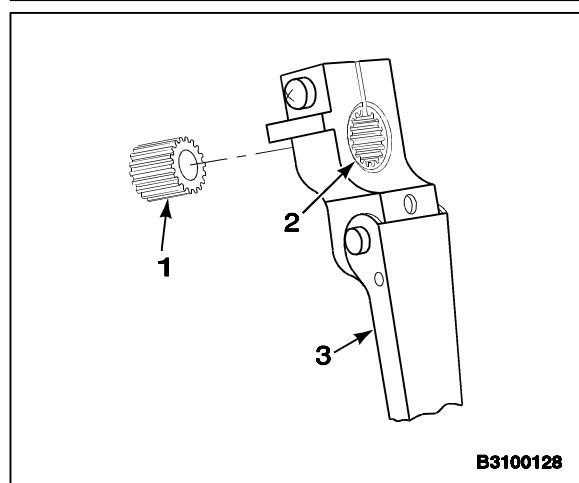

END OF TASK

INITIAL SETUP

**Applicable Configurations:**

All

**Tools:**

- Aircraft Mechanic's Tool Kit, NSN 5180-00-323-4692
- Soft Jawed Vise
- Workstand
- Cotter Pin, 1/8 Inch

**Materials:**

Lockwire (E233)

**Personnel Required:**

- CH-47 Helicopter Repairer
- Inspector

**References:**

TM 55-1520-240-23P

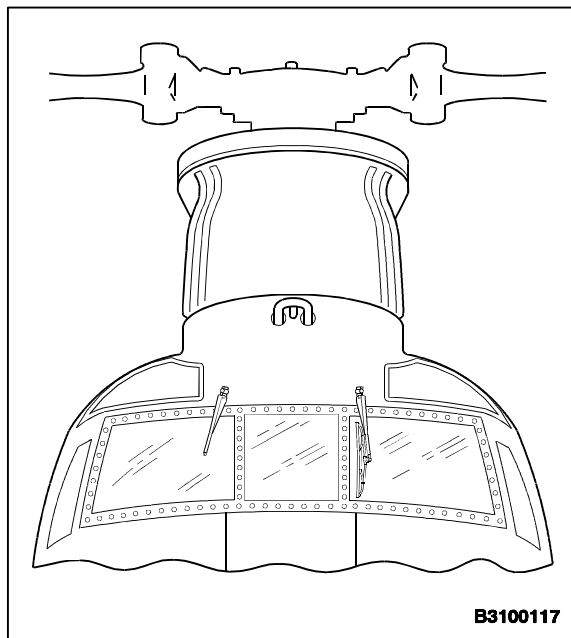

**NOTE**

There are two windshield wiper arms. Installation procedure is same for both. Right wiper is shown here.

Deleted.

1. Put arm hub (1) in vise (2).
2. Pull back on arm (3) against spring tension.
3. Insert cotter pin (4) in hole (5) in arm (3).
4. Remove arm (3) from vise (2).

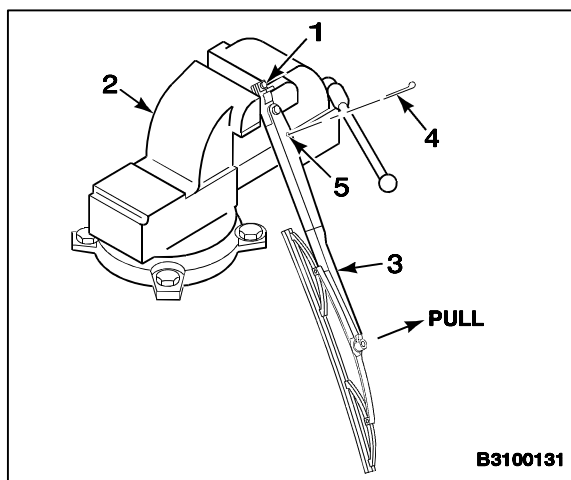

5. Check sleeve (6) and arm hub (1) for stripped grooves. There shall be no stripped grooves.
6. Install sleeve (6) into arm hub (1).

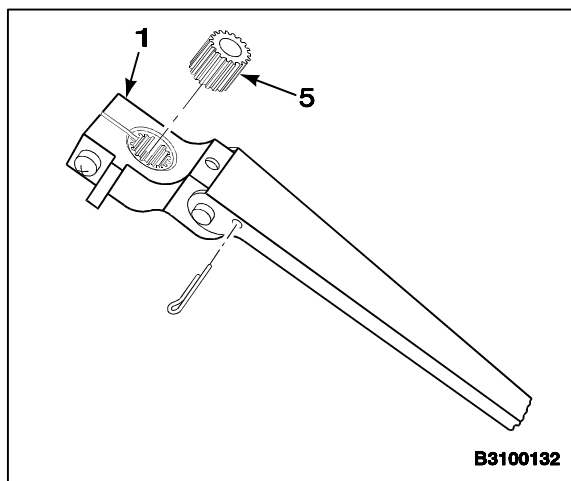

7. Position arm hub (1) on splined shaft (7) above windshield (8). Wiper arm (3) should be as close as possible to parked position. If wiper arm is in parked position, go to step 11. If wiper arm is not in parked position, go to step 8.

**NOTE**

Parked position is at the inboard edge of the windshield.

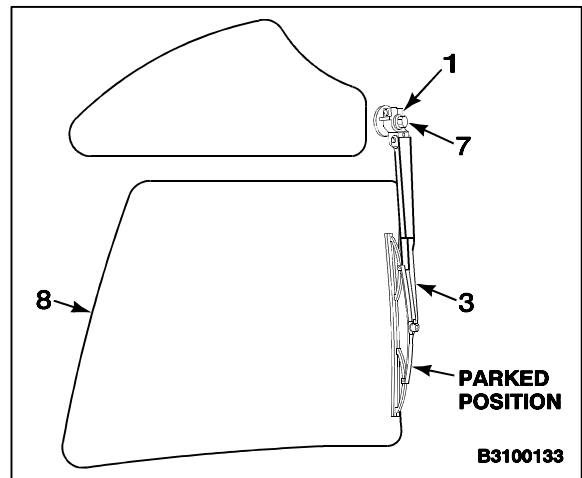

8. Remove arm (3) and sleeve (6).
9. Rotate sleeve (6) slightly in direction arm (3) must be moved to get arm into parked position.
10. Repeat steps 7 thru 9 until arm (3) can be installed in parked position.

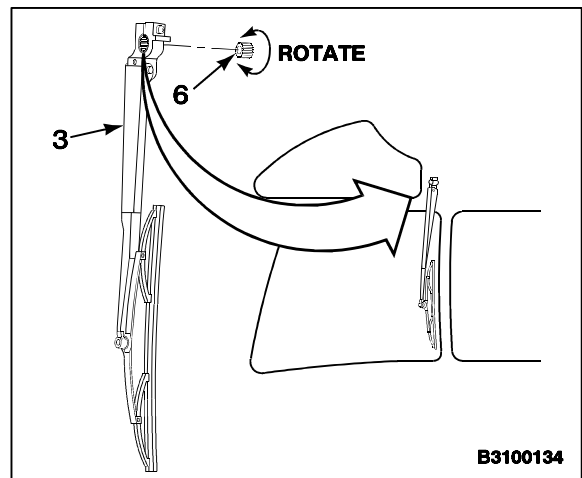

11. Tighten screw (9).
12. Install washer (10) and retaining bolt (11).
13. Lockwire screw (9) and bolt (11) together. Use lockwire (E233).
14. Remove cotter pin (4) from hole (5).

**INSPECT**

15. Remove protective paper and tape from windshield (8).

**FOLLOW-ON MAINTENANCE:**

Adjust windshield wiper arm pressure (Task 12-37).  
Check windshield wiper system operation (TM 55-1520-240-T).

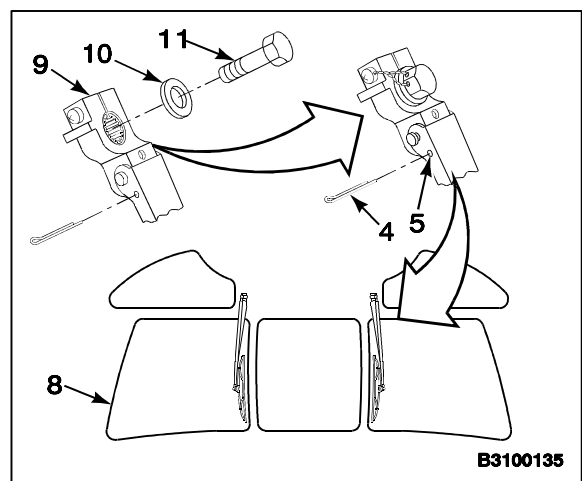

END OF TASK

INITIAL SETUP

**Applicable Configurations:**

All

**Tools:**

Aircraft Mechanic's Tool Kit, NSN 5180-00-323-4692

**Materials:**

As Required

**Personnel Required:**

CH-47 Helicopter Repairer

**Equipment Condition:**

Battery Disconnected (Task 1-39)  
 Electrical Power Off  
 Hydraulic Power Off  
 Windshield Wiper System in PARK  
 (TM 55-1520-240-T)  
 Overhead Panel Lowered (Task 9-97)

1. Remove lockwire from both nuts (1) and electrical plug (2).
2. Back off nuts (1) from motor (3).
3. Disconnect plug (2).

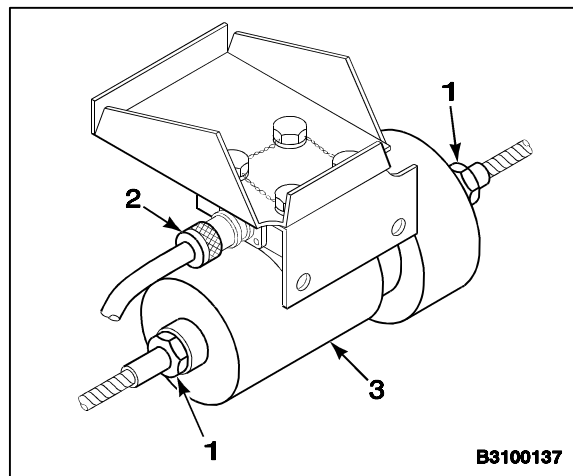
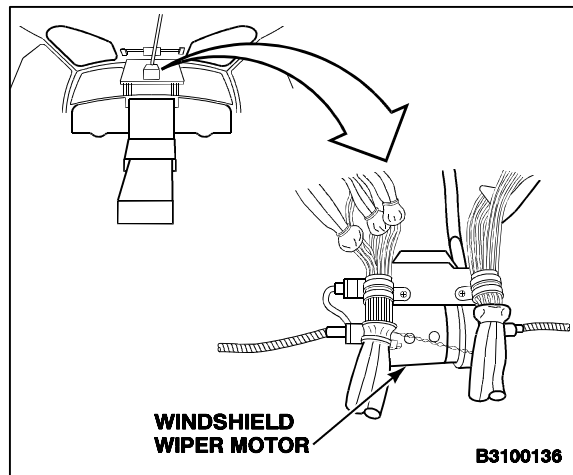

4. Remove lockwire from four mounting bolts (4).
5. Support motor (3) and remove four bolts (4) and washers (5).
6. Separate motor (3) from bracket (6) and remove two spacers (7) from between mount (8) and motor.
7. Disconnect two shafts (9). Keep couplings (10) in shafts. Cap shafts.
8. Remove motor (3).

**FOLLOW-ON MAINTENANCE:**

None

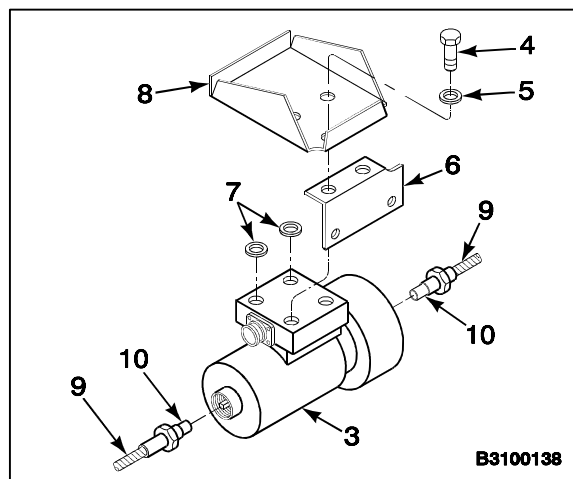

Task 12-43, pages 12-97 and 12-98 have been deleted.

END OF TASK



INITIAL SETUP

**Applicable Configurations:**

All

**Tools:**

- Electrical Repairer's Tool Kit, NSN 5180-00-323-4915
- Ammeter
- Fan
- Power Supply, 28 VDC
- Stopwatch
- Resistor Box (XW20419-2)
- Vise
- Adjustable Wrench
- Switch, Rotary (XW20336-2)
- Coupling (W20075)

**Materials:**

None

**Personnel Required:**

- Aircraft Electrician
- Inspector

**Equipment Condition:**

- Off Helicopter Task
- Test Setup

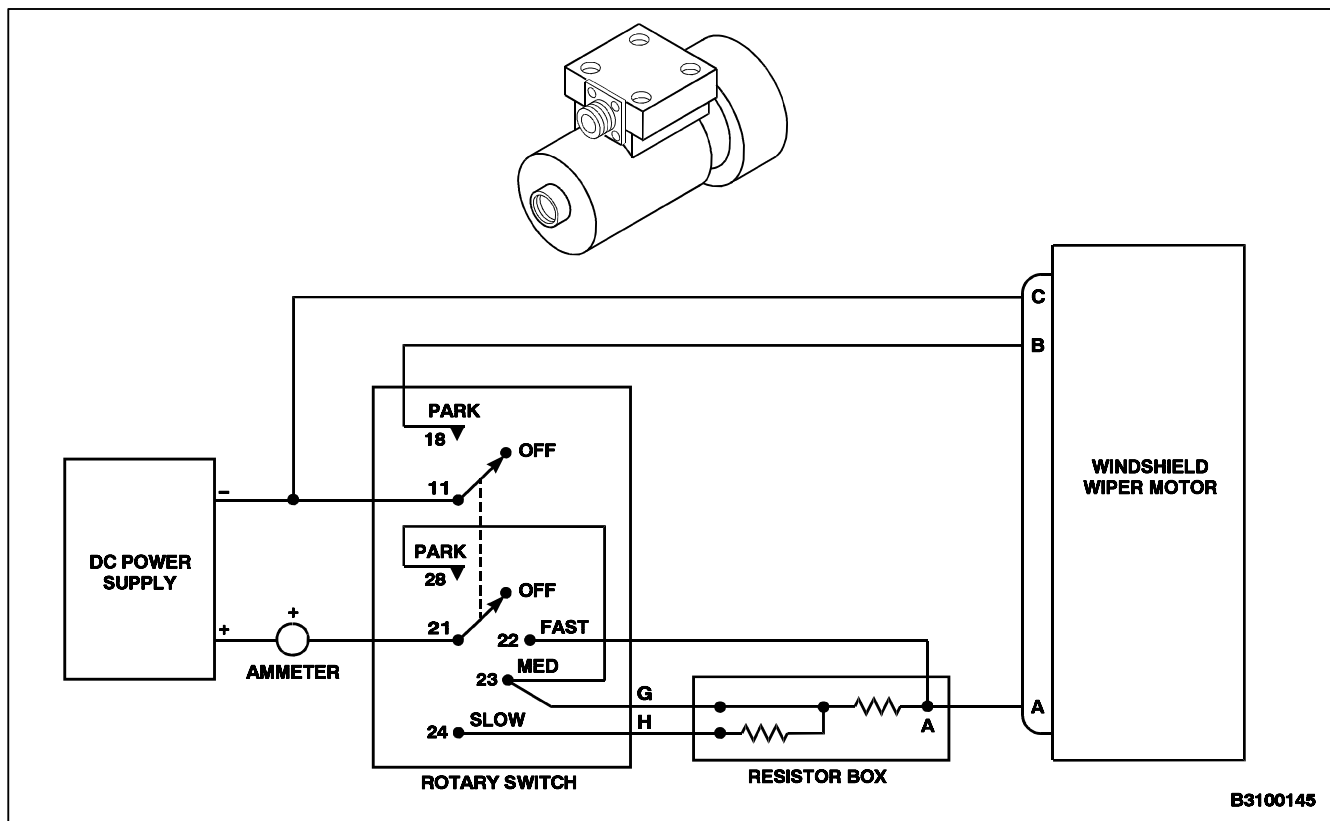



1. Connect motor (1) to test setup.

**PERFORM RUN IN TEST.**

2. Set switch (2) to SLOW.



Use fan to cool resistor box during run in test.

3. Apply dc power and run motor (1) for **1 hour**. Use fan (3) to cool resistor box (4).
4. Check motor (1). Motor shall not have extreme noise or vibration.
5. Set switch (2) to OFF.

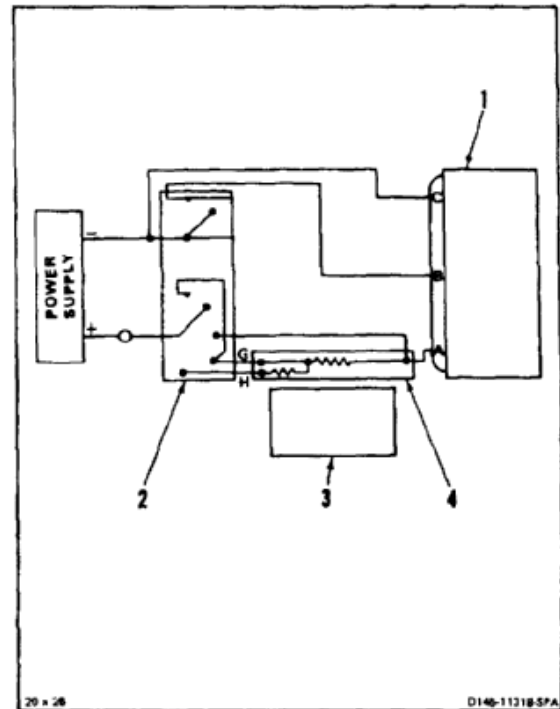

**TEST THERMOPROTECTOR**

6. Install motor (1) in vise (5).
7. Install coupling (6) in motor (1). Use wrench (7) to hold coupling.
8. Turn switch (2) to FAST. Motor (1) shall turn off in less than **30 seconds**.
9. Remove wrench (7) and coupling (6). Motor (1) shall restart.
10. Set switch (2) to OFF. Remove motor (1) from vise (5).

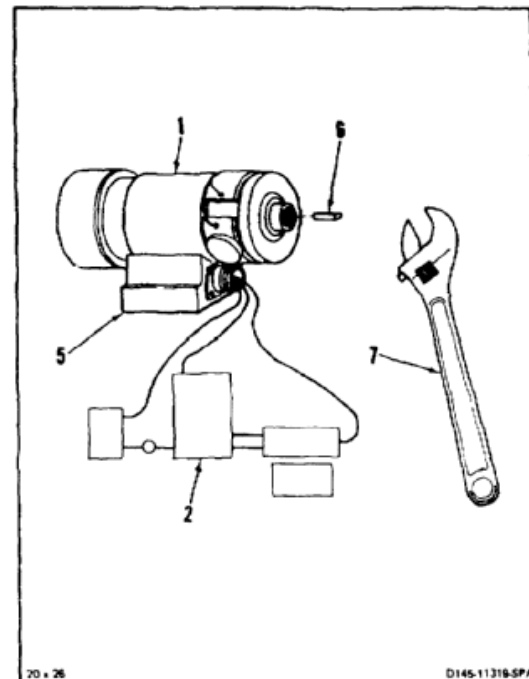

**TEST CURRENT DRAIN**

11. Set switch (2) to FAST.
12. Check ammeter (8). Current shall not exceed **5 amperes**.
13. Remove motor (1) from test setup.
14. Remove dc power supply.

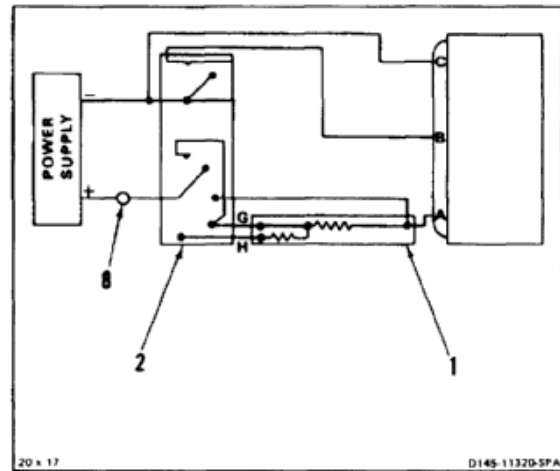
**FOLLOW-ON MAINTENANCE:**

None

END OF TASK

12-102

INITIAL SETUP

**Applicable Configurations:**

All

**Tools:**

Aircraft Mechanic's Tool Kit, NSN 51 80-00-323-4692

**Materials:**

- Lockwire (E233)
- Lockwire (E229)

**Personnel Required:**

- Medium Helicopter Repairer
- Inspector

**References:**

- TM 55-1520-240-23P
- TM 55-1520-240-T

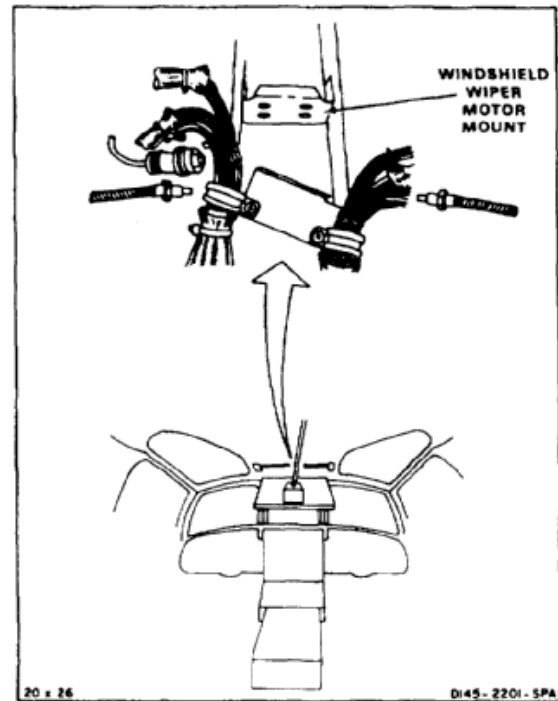

1. Position motor (1) on mount (2) with electrical connector (3) facing left.
2. Temporarily install four bolts (4) and washers (5).
3. Connect electrical plug (6) to connector (3).
4. Apply electrical power.
5. Make sure wiper switch is at PARK (TM 55-1520-240-T).
6. Shut down electrical power.
7. Remove four bolts (4) and washers (5).

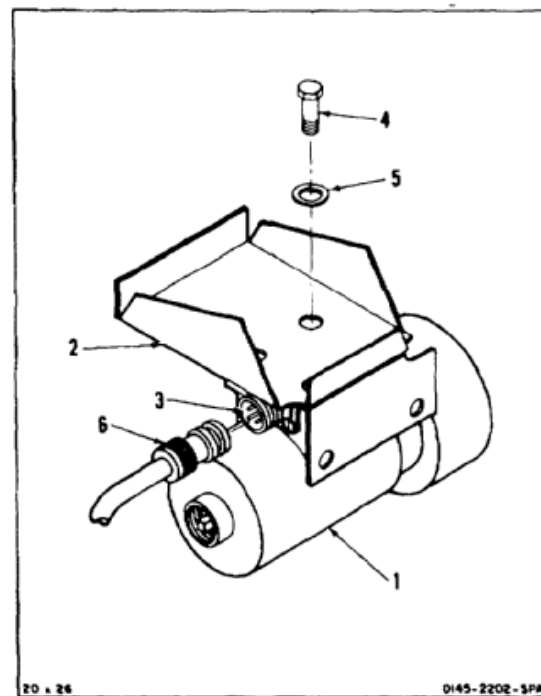

8. Remove caps and connect two shafts (7) to motor (1). Do not tighten nuts (8) at this time.
9. Lockwire plug (6). Use lockwire (E229).
10. Position bracket (9) and two spacers (10) between motor (1) and mount (2).
11. Install four bolts (4) and washers (5).

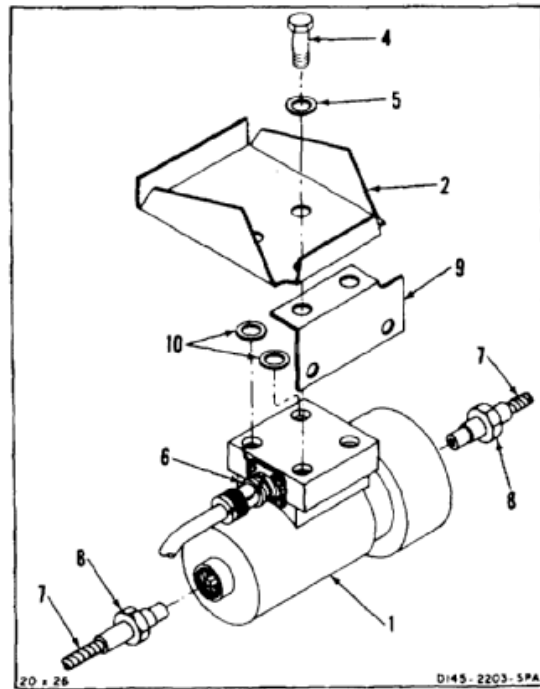

12. Tighten two nuts (8).
13. Lockwire nuts (8) to each other across motor (1). Use lockwire (E233).
14. Lockwire four mounting bolts (4) together. Use lockwire (E233).

**INSPECT**

**FOLLOW-ON MAINTENANCE:**

Secure overhead panel (Task 9-98).  
 Check wiper operation (TM 55-1520-240T).

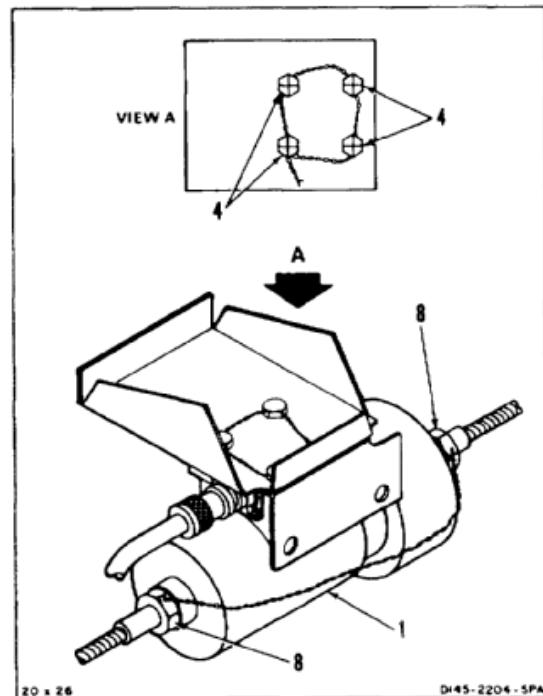

END OF TASK

**12-46 REMOVE WINDSHIELD WIPER DRIVESHAFT**

12-46

**INITIAL SETUP****Applicable Configurations:**

All

**Tools:**

Aircraft Mechanic's Tool Kit, NSN 51 80-00-323-4692

**Materials:**

None

**Personnel Required:**

Medium Helicopter Repairer

**Equipment Condition:**

Battery Disconnected (Task 1-39)  
 Electrical Power Off  
 Hydraulic Power Off  
 Overhead Panel Lowered (Task 9-97)  
 Cockpit Overhead Acoustic Blanket Removed (Task 2-107)

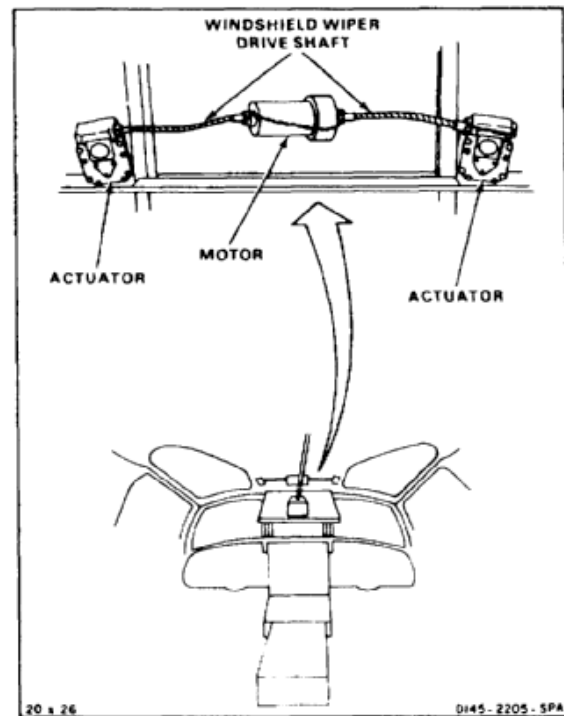
**NOTE**

There are two windshield wiper drive shafts. Procedure is same for removing right or left shaft. Right shaft is shown here.

1. Remove lockwire from two nuts (1).
2. Back off nut (1) from actuator (2).
3. Back off nut (1) from motor (3).
4. Disconnect shaft (4) from motor (3) and actuator (2). Make sure couplings (5) stay in shaft.
5. Remove shaft (4) and cap ends.

**FOLLOW-ON MAINTENANCE:**

None

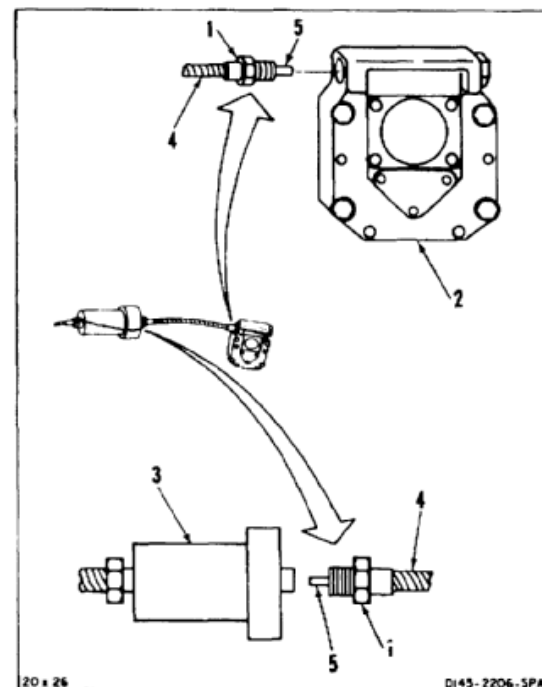

END OF TASK

## INITIAL SETUP

**Applicable Configurations:**

All

**Tools:**

Aircraft Mechanic's Tool Kit, NSN 5180-00-323-4692

**Materials:**

Lockwire (E233)

**Personnel Required:**Medium Helicopter Repairer  
Inspector**References:**

TM 55-1520-240-23P

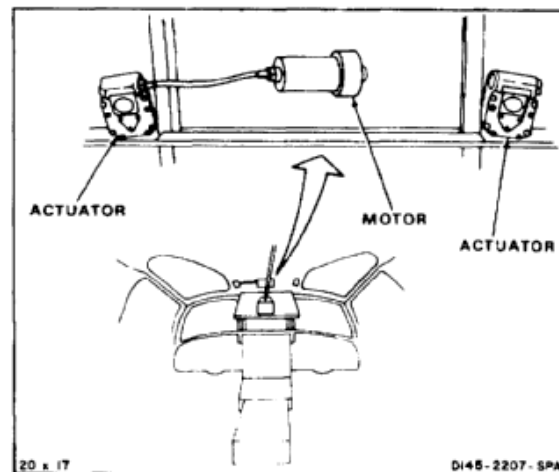
**NOTE**

There are two windshield wiper drive shafts. Procedure is same for installing right or left shaft. Right shaft is shown here.

1. Remove caps from shaft (1). Make sure couplings (2) stay in shaft and shaft turns freely.
2. Connect shaft (1) to motor (3) and actuator (4). Tighten both nuts (5).
3. Lockwire nut (5) at motor (3) to nut on other side of motor. Use lockwire (E233).
4. Lockwire nut (5) at actuator (4) to cap nut (6) on other side of actuator. Use lockwire (E233).

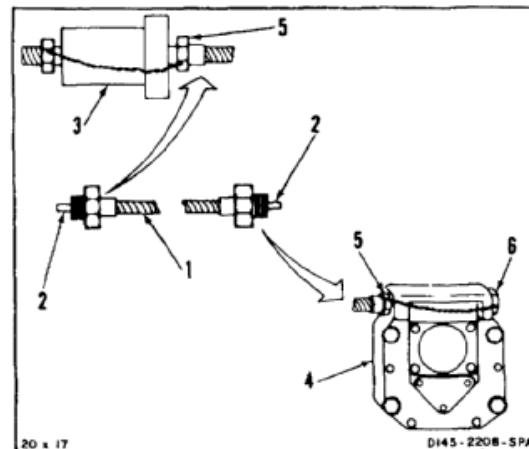
**INSPECT****FOLLOW-ON MAINTENANCE:**

Secure overhead panel (Task 9-98).  
Check wiper operation (TM 55-1520-240-T).  
Install acoustic blanket (Task 2-108).

END OF TASK

12-106

**12-48 REMOVE WINDSHIELD WIPER ACTUATOR (CONVERTER)**

12-48

**INITIAL SETUP****Applicable Configurations:**

All

**Tools:**

Aircraft Mechanic's Tool Kit, NSN 51 80-00-323-4692  
Workstand

**Materials:**

None

**Personnel Required:**

Medium Helicopter Repairer

**Equipment Condition:**

Battery Disconnected (Task 1-39)  
Electrical Power Off  
Hydraulic Power Off  
Windshield Wiper Arm Removed, Right or Left Arm  
as Required (Task 12-39)  
Cockpit Overhead Acoustic Blanket Removed (Task  
2-107)

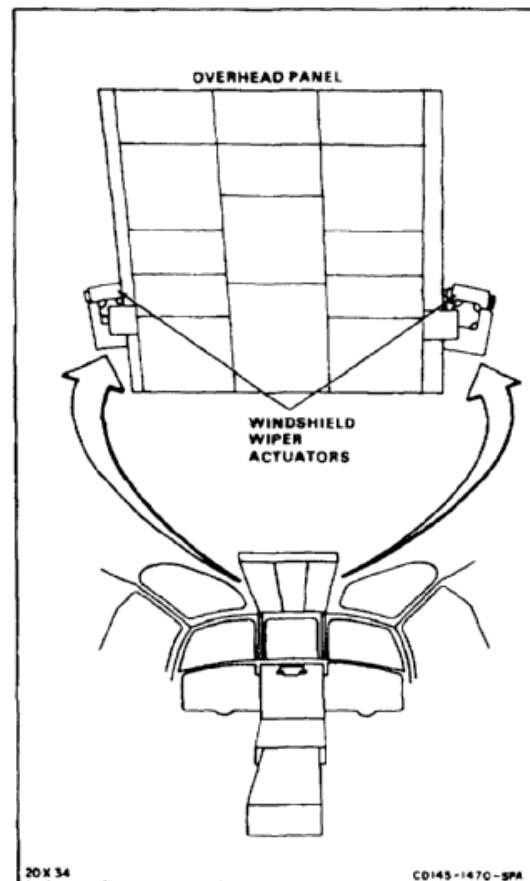
**NOTE**

There are two windshield wiper actuators (converters), one for each wiper. Removal procedure is same for both. Right side actuator is shown here.

1. Remove sealant where actuator shaft (1) goes through fuselage above windshield (2).

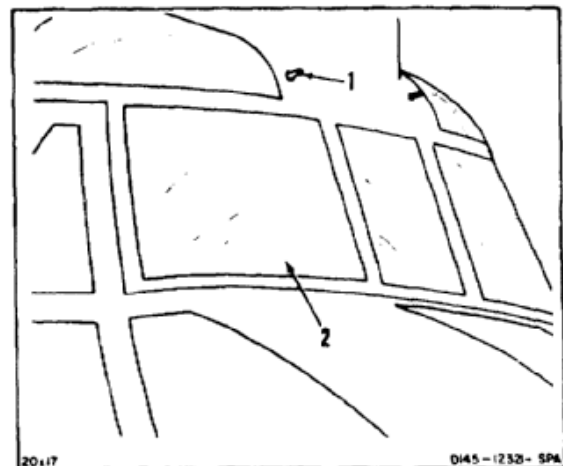

2. Remove lockwire from nut (3).
3. Loosen nut (3) from actuator (4).

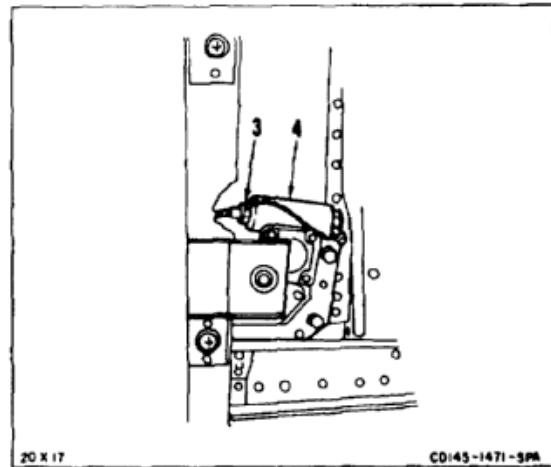

4. Remove four bolts (5) and washers (6).
5. Disconnect flexible shaft (7) from actuator (4). Make sure coupling (8) stays in shaft.
6. Remove actuator (4).

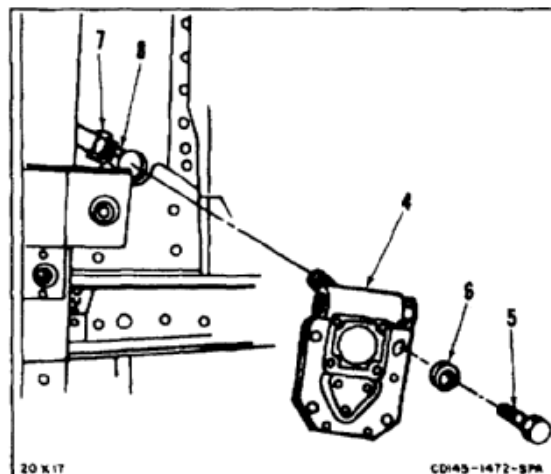
**FOLLOW-ON MAINTENANCE:**

None

END OF TASK

12-108



## INITIAL SETUP

**Applicable Configurations:**

All

**Tools:**

Aircraft Mechanic's Tool Kit, NSN 51 80-00-323-4692  
Workstand

**Materials:**

Gloves (E186)  
Lockwire (E233)  
Sealant (E336)

**Parts:**

Flexible Shaft

**Personnel Required:**

Medium Helicopter Repairer  
Inspector

**References:**

TM 55-1520-240-23P

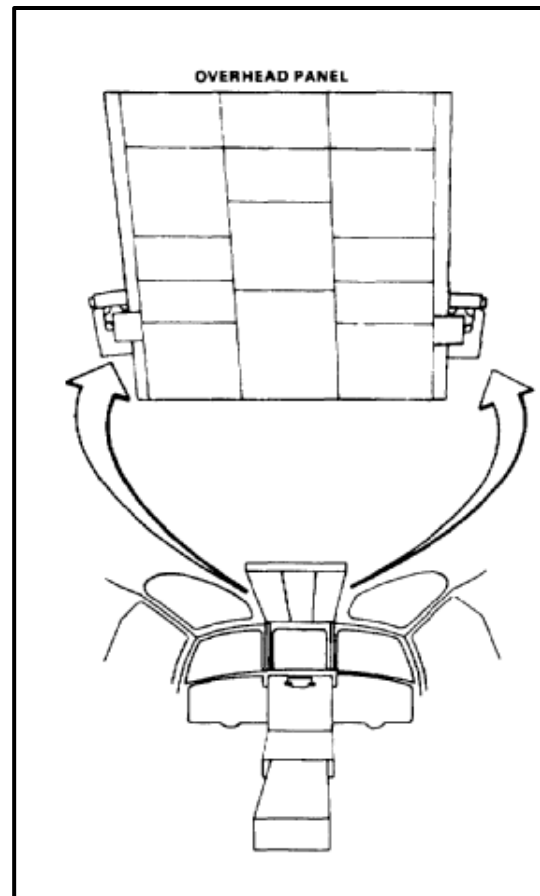
**NOTE**

There are two windshield wiper actuators (converters), one for each wiper. Installation procedure is same for both. Right side actuator is shown here.

1. Remove nut (1) from inboard side of actuator (2).

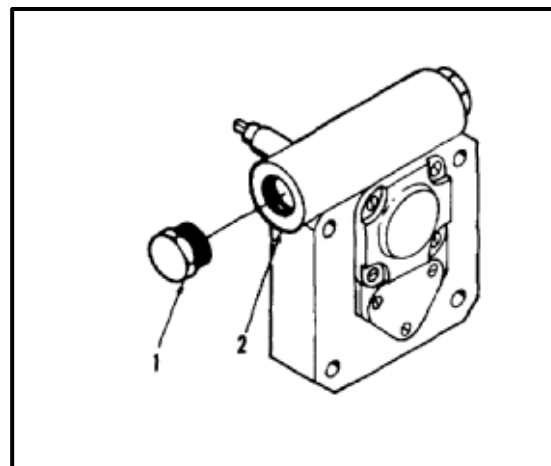

2. Insert spare flexible shaft (3) in actuator (2).

**NOTE**

Actuator is in parked position when splined shaft stops and an installed wiper would be at inboard edge of windshield. A few more rotations of flexible shaft will move splined shaft in opposite direction.

3. Rotate shaft (3) to move splined shaft (4) of actuator (2) to parked position.
4. Remove shaft (3).

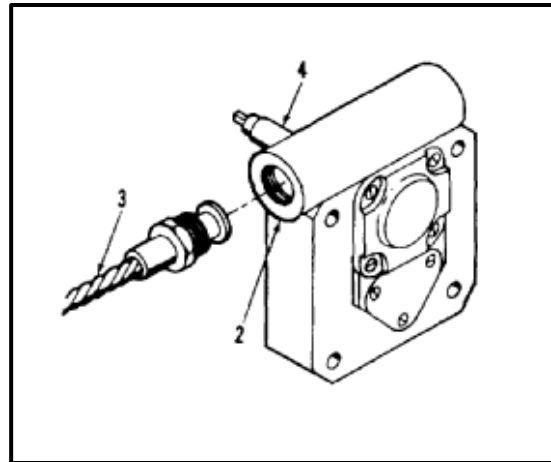

5. Position actuator (2) on mount (5) with shaft (4) through hole (6).

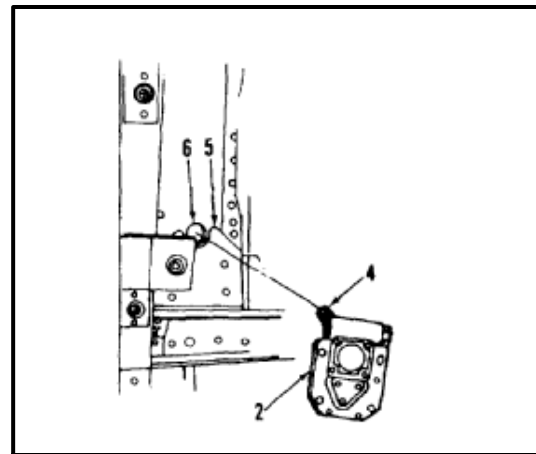

6. Connect flexible shaft (7) to actuator (2).
7. Install actuator (2) with four bolts (8), and washers (9).
8. Tighten nut (10).
9. Lockwire nut (10) to nut (11) on opposite side of actuator (2). Use lockwire (E233).

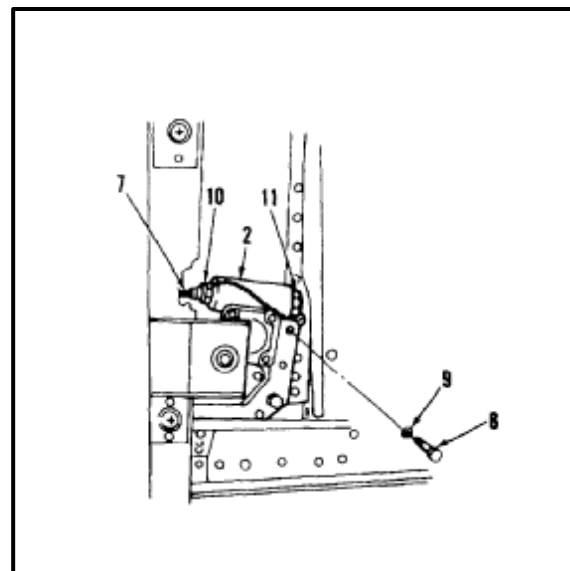

**WARNING**

Sealant (E336) can irritate skin and cause burns. Avoid contact with skin, eyes, and clothing. In case of contact, immediately flush skin or eyes with water for at least **15 minutes**. Get medical attention for eyes.

10. Apply sealant (E336) where shaft (4) comes through helicopter fuselage above windshield (12). Wear gloves (E186).

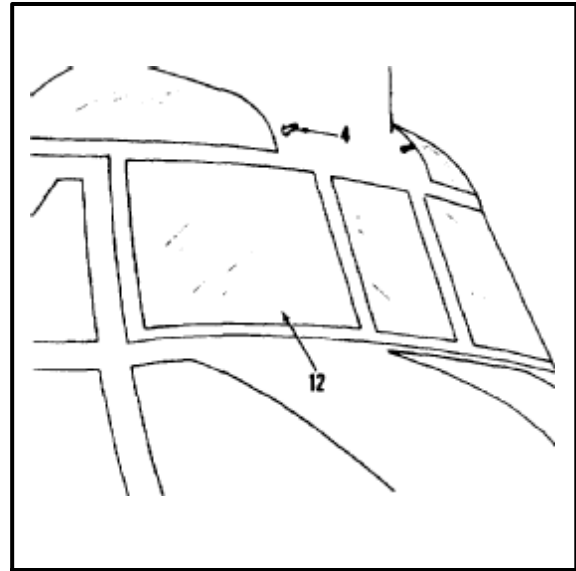
**INSPECT****FOLLOW-ON MAINTENANCE:**

- Install windshield wiper arm (Task 12-41).
- Check windshield wiper system operation (TM 55-1520-240-T).
- Install cockpit overhead acoustic blanket (Task 2-108).

END OF TASK



# **CHAPTER 13**

# **ENVIRONMENTAL CONTROLS**

## **SECTION I**

### **ENVIRONMENTAL SYSTEM DESCRIPTION AND THEORY OF OPERATION**

**DESCRIPTION**

The environmental system provides heat and ventilation for the helicopter. The system consists of a heater and fan mounted between an air inlet duct and exhaust pipe, an ignition unit, control switches, a temperature controller and thermostat, cockpit and cabin ducting, and fuel delivery components.

The heater is located in a compartment on the right forward end of the cabin, ahead of the cabin door. It is capable of **200,000 btu/hr** output.

A fuel control unit draws fuel from the right side fuel system and controls the pressure and flow to the heater combustion chamber.

The fan draws air from outside through the air inlet duct and forces it through the heater. Some air is mixed with fuel and ignited in the heater combustion chamber and other air is heated and sent through the duct network. The fan can also supply fresh air for ventilation. Exhaust gases are sent through the exhaust pipe and discharged outside, above and aft of the air inlet.

The ignition unit supplies a high voltage current that produces a continuous spark in the heater combustion chamber to ignite the fuel and air mixture. Unburned fuel is drained overboard.

The thermostat maintains a steady temperature in the cabin by causing a relay in the temperature controller to open or close as cabin temperature fluctuates. In this way, the controller controls the electrical circuit to the heater fuel system, interrupting or resuming fuel flow, as required.

The heater system is protected from overheating by three thermostatic switches. A differential air pressure switch shuts down the heater when there is not enough air for safe operation.

Switches on the overhead panel control heater operation. A temperature controller adjusts the cabin thermostat setting. Push-pull controls in the cockpit regulate air flow through the ducting.

**THEORY OF OPERATION**

The heater and fan are both controlled by a control switch and a start button on the cockpit overhead panel. The switch has three positions, labeled OFF, VENT BLOWER ONLY, and HEATER ON. The button is spring-loaded and is labeled HEATER START. When the switch is set to HEATER ON and the button is pressed and released, the system is set in operation as follows:

- a. Relay 082K3 is energized by **28 volts** from the No. 2 dc bus through the normally closed (NC) contacts of overheat switch 082A5. This action energizes relay 082K2 and fan relay 082K1, connecting **115 volt** 3-phase ac from the No. 2 ac bus to the heater fan.
- b. When the fan has been in operation for **10 seconds**, time-delay (TD) relay 082K4 and air pressure switch 082A4 will close. The delay allows time for the fan to purge the heater of combustible vapor and to build up enough air pressure to activate the switch. The closed TD relay and switch allow voltage to close relay 082K5, operating master fuel valve 082L1, the fuel pump (located in fuel control unit 082A2) and ignition unit 082A3. The closed relay also connects power to the temperature controller and thermostat (See step e).
- c. The open master fuel valve unit allows fuel to be delivered from the boost pump in the right main tank to the fuel control unit. In the fuel control unit, the fuel passes through a filter, a pressure regulator and a pump. The pump raises fuel pressure to **100 psi**, controlled by a pressure relief valve, and delivers it through a solenoid valve to the heater. The solenoid valve is energized through the temperature controller and thermal cycling switch (See step e).
- d. Fuel enters the heater combustion chamber, where it is atomized by a spray nozzle and mixed with air provided by the fan through the combustion air tube. The mixture is ignited by a spark plug supplied with high tension voltage from the ignition unit. The remainder of the pressurized air flows around the combustion chamber, picking up heat as it does. The heated air is then distributed through ducting to the cockpit and cabin. Air flow direction and volume is controlled by manual operation of valves in the ducting.
- e. The temperature of the heated air is controlled by the combined action of CABIN TEMP SELECTOR switch 082S1, temperature controller 082A1, and cabin thermostat 082S4.

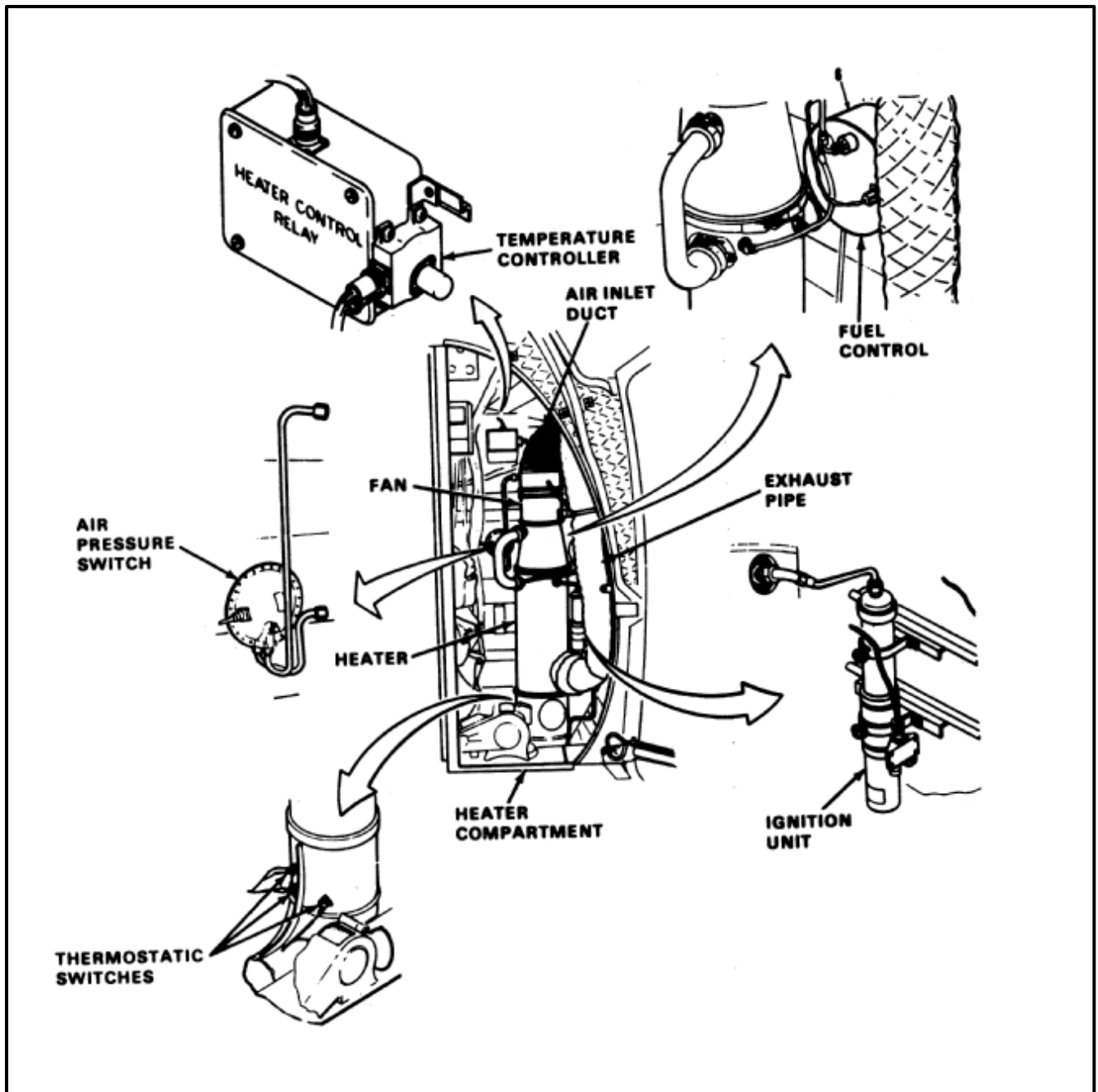

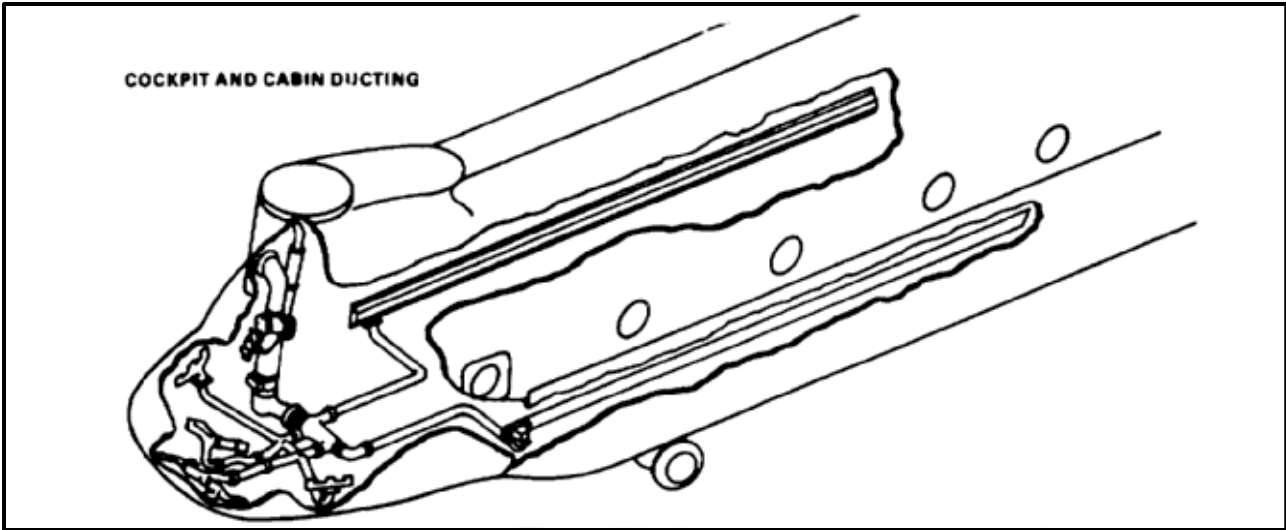



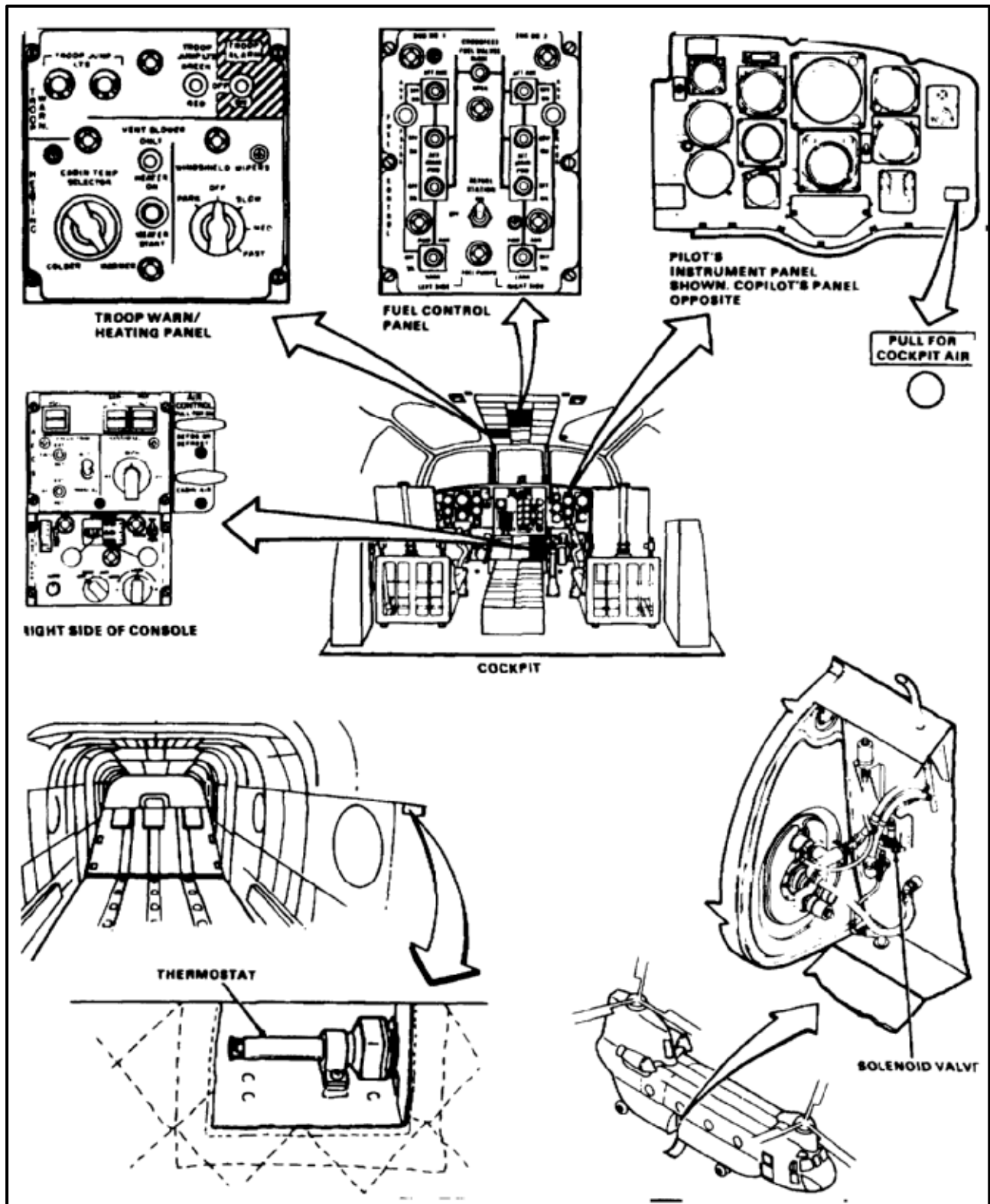

- The switch is on the cockpit overhead panel. The controller is in the heater compartment on the side of the HEATER CONTROL RELAY box at sta. 95. The thermostat is on the left side of the cabin at sta. 335.
- f. Power is provided through the switch to the controller and thermostat when relay 082K5 is energized (See step b). At the same time, power passes through the controller and thermal cycling switch 082A7 to open the solenoid valve in fuel control 082A2, permitting fuel to be delivered to the heater as described in step c.
- g. The cabin thermostat consists of a column of mercury surrounded by a heater winding. Current passes through the variable resistor within the temperature controller to heat the winding. When the winding raises the temperature of the mercury to **93°F (34°C)**, it opens contacts within the temperature controller relay. This removes power from the solenoid valve within the fuel control, shutting off fuel to the heater. It also removes power from the heater winding, allowing the mercury column to cool and contract. When this happens, the relay contacts open, power is restored to the fuel solenoid valve, and the heater starts.
- h. Protection for the heater is provided by three thermal switches at the base of the heater. Cycling switch 082A7 interrupts the circuit to the fuel control solenoid valve when temperature of the air leaving the heater goes over **250°F (121°C)**. Overheat switch 08285 is a backup switch that functions if the cycling switch fails. It opens to deenergize relay 082K3 whenever air in the transition assembly below the heater exceeds **350°F (177°C)**. This shuts off the heater, but lets the fan continue to operate. At the same time, the HEATER HOT caution light on the master caution panel comes on. When this happens, the heater cannot be operated again until the transition assembly has cooled below **250°F (121°C)**. At that time, the heater can be started again by pressing the HEATER START button. A fan overrun switch 08286 keeps the fan operating after the heater has been shut down until the temperature within the heater drops below **120°F (49°C)**. If the temperature rises to **120°F (49°C)** again, the overrun switch will close and the fan will come on again. This cycling will continue until the temperature stays below **120°F (49°C)**.
- i. Additional heater protection is provided by differential air pressure switch 082A4, on the sta. 95 bulkhead. This switch shuts down the fuel and ignition systems by deenergizing relay 082K5 if air pressure through the fan drops below **1.25 to 1.75 inches** of water.
- j. When the switch on the cockpit overhead panel is set to VENT FAN ONLY, only those contacts within the switch that energize the heater fan are closed. The blower then forces unheated ventilating air through the ducting.

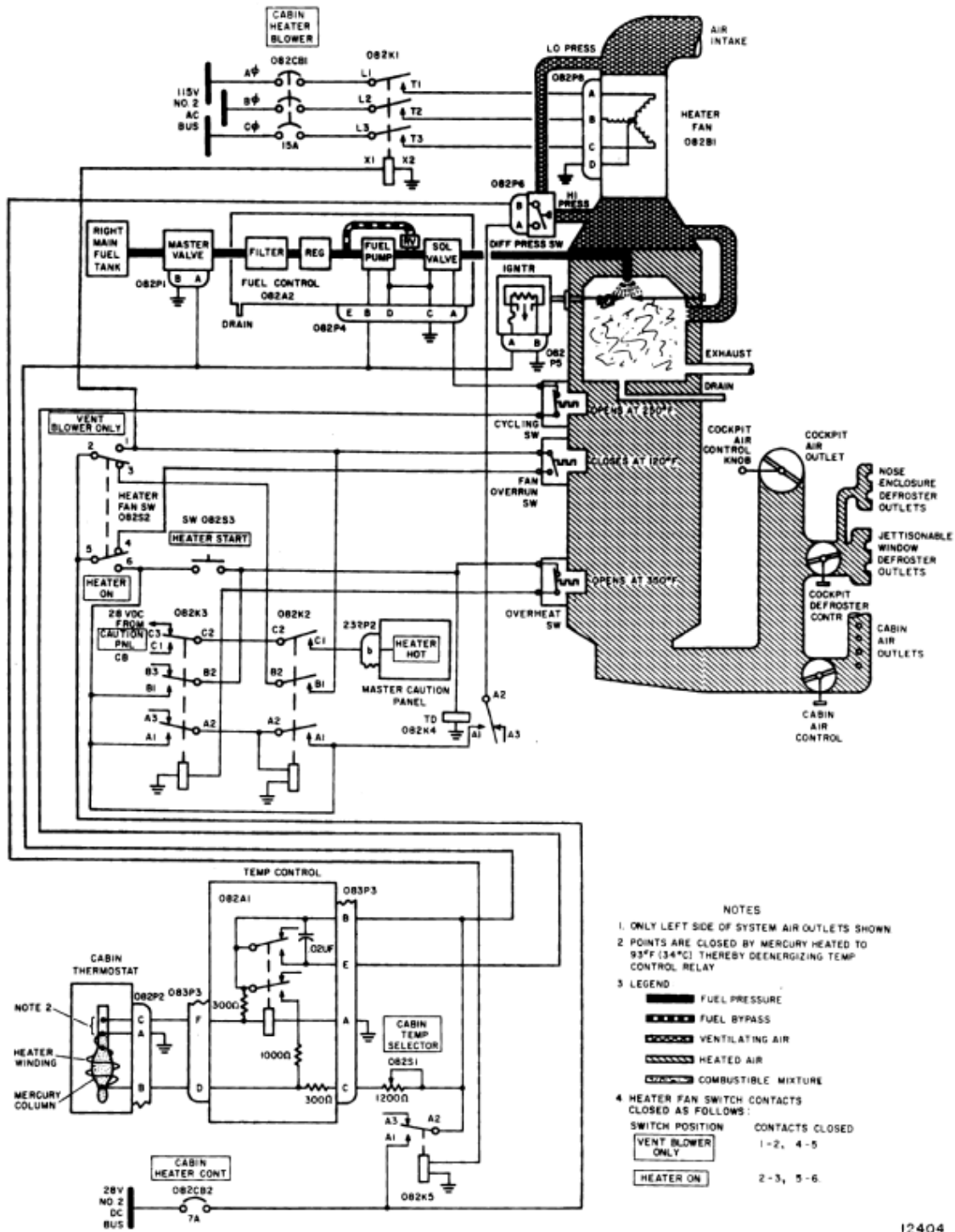

12404

END OF TASK



## **SECTION II ENVIRONMENTAL SYSTEM**

INITIAL SETUP

**Applicable Configurations:**

All

**Tools:**

Aircraft Mechanic's Tool Kit, NSN 5180-00-323-4692

**Materials:**

As Required

**Personnel Required:**

Medium Helicopter Repairer (2)

**Equipment Condition:**

Battery Disconnected (Task 1-39)

Electrical Power Off

Heater Compartment Acoustic Blanket Removed  
(Task 2-208)

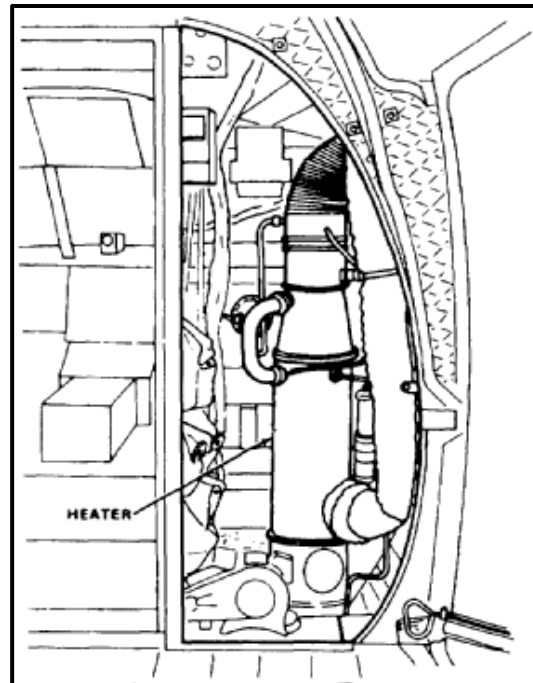

1. Disconnect shielded lead (1) from spark igniter (2).
2. Disconnect fuel tube (3) from heater connection (4). Plug tube.

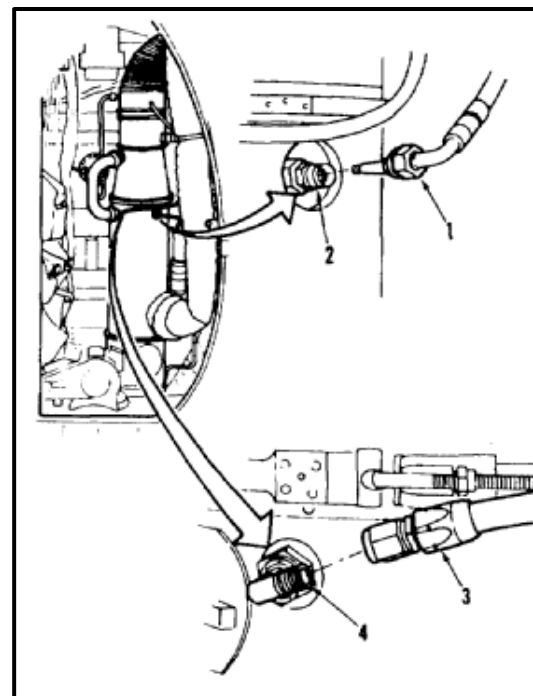

**13-2 REMOVE HEATER (Continued)**

13-2

3. Disconnect low pressure tube (5) from air inlet duct (6).
4. Disconnect high pressure tube (7) from adapter (8).
5. Loosen nuts (9) on low pressure tube (5) and high pressure tube (7) at air pressure switch (10).
6. Turn tubes (5 and 7) away from heater (11).

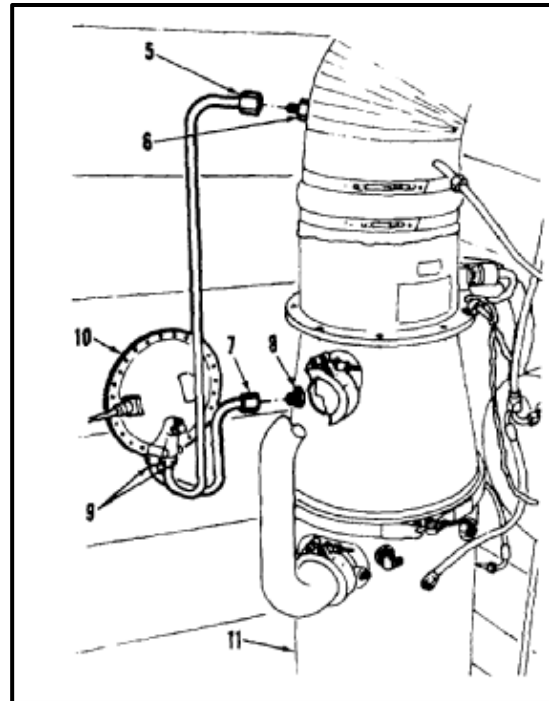

7. Remove lockwire from electrical connector (12).
8. Remove screw (13), two washers (14), clamp (15), wires (16), and nut (17) from fan (18).

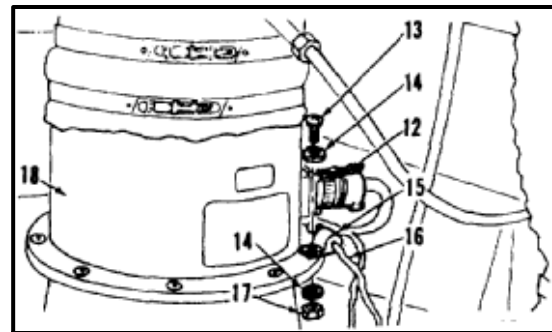

9. Disconnect electrical connector (12) from fan (18).
10. Remove clamps (19) from air inlet duct (6).

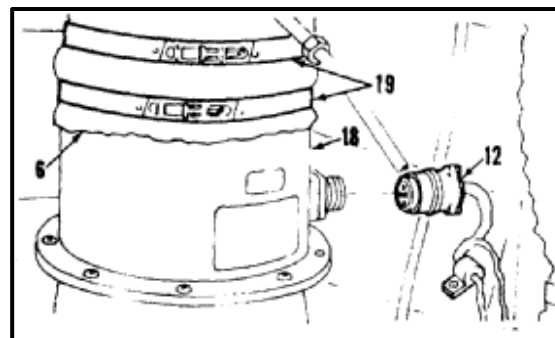

11. Slide air inlet duct (6) off fan (18) and push duct to side.
12. Remove lacewire from bottom section of exhaust shroud elbow (20).

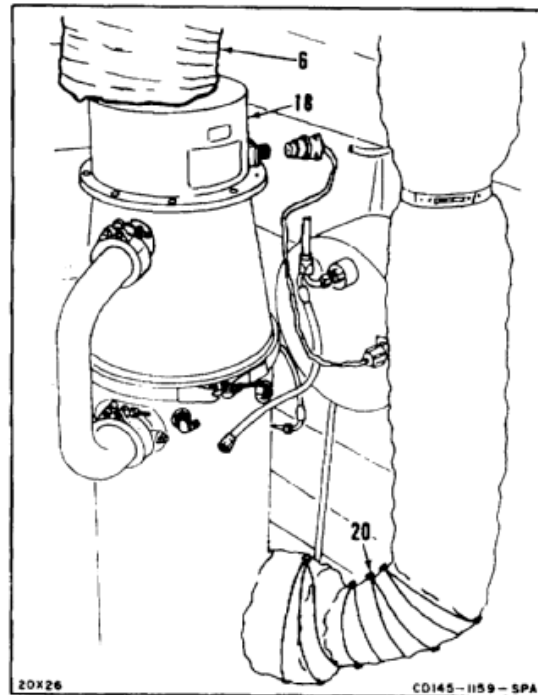

13. Remove exhaust shroud elbow (20) from exhaust pipe (21).
14. Remove lockwire from clamp (22).

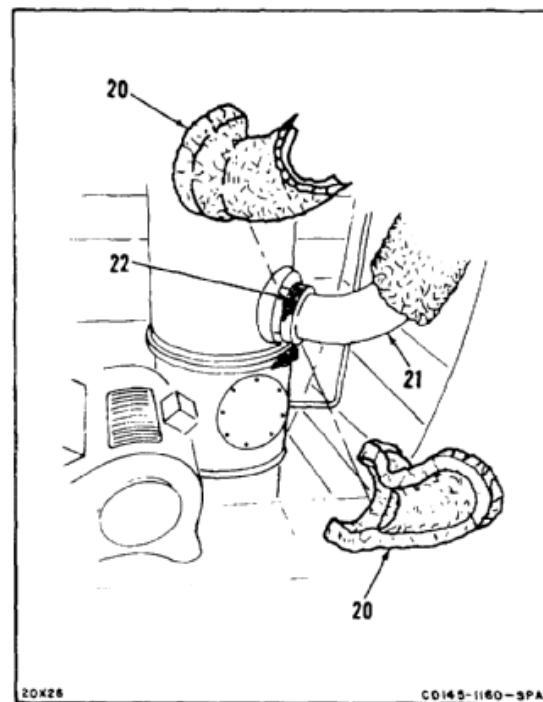



13-2 REMOVE HEATER (Continued)

- 15. Remove clamp (22) from pipe (21).
- 16. Remove eight screws (23) and washers (24) from access cover (25).

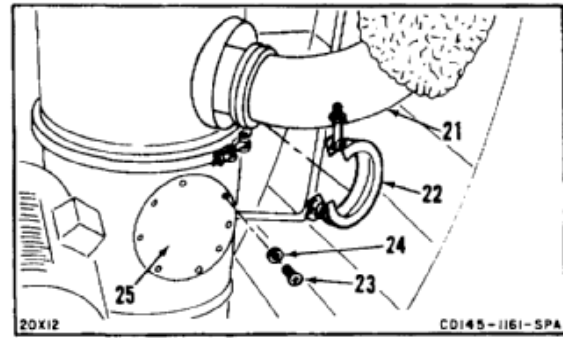

- 17. Remove access cover (25) and seal (26) from transition duct (27).

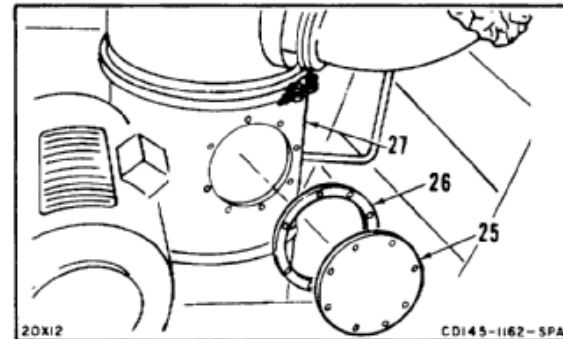

- 18. Disconnect drain tube (28) at heater connection (29) inside transition duct (27).
- 19. Remove lockwire from clamp (30).

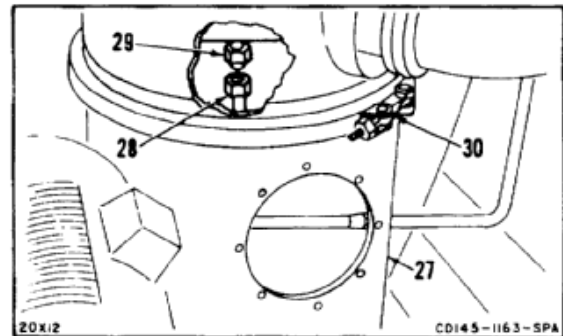

- 20. Remove clamp (30) from heater (11) and transition duct (27).

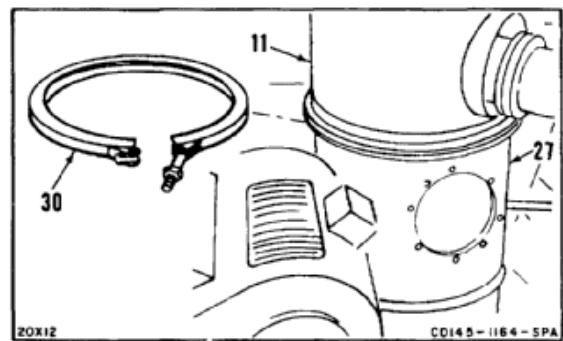

21. Remove heater (11), adapter (8), and fan (18).

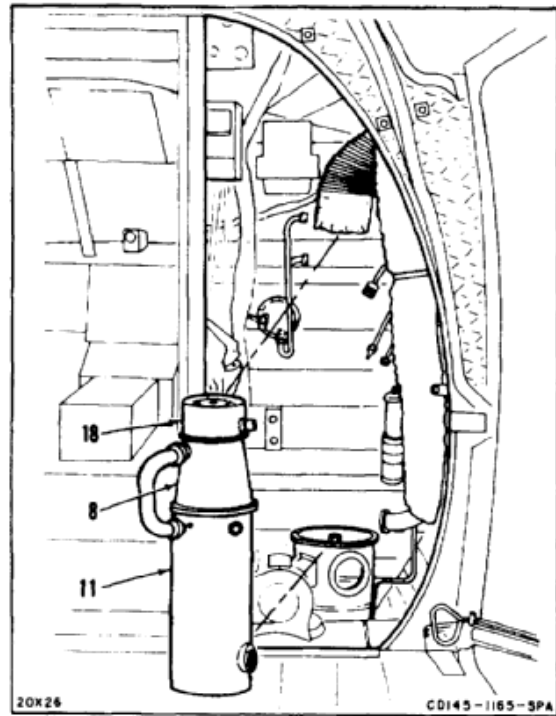

22. Remove lockwire from two clamps (31).

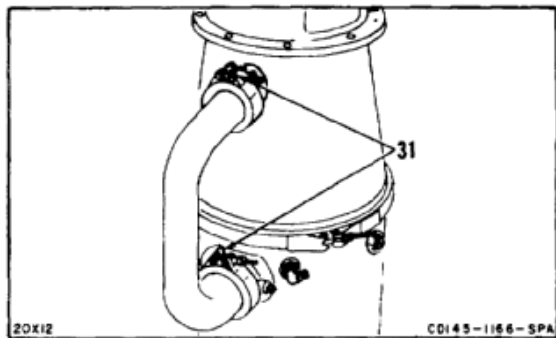

23. Remove two clamps (31) and combustion tube (32) from adapter (8) and heater (11).

24. Remove lockwire from clamp (33).

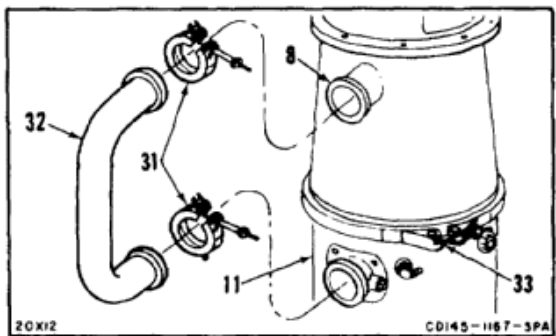

**13-2 REMOVE HEATER (Continued)**

13-2

25. Remove clamp (33) from adapter (8) and heater (11).
26. Lift adapter (8) and fan (18) from heater (11).

***FOLLOW-ON MAINTENANCE:***

None

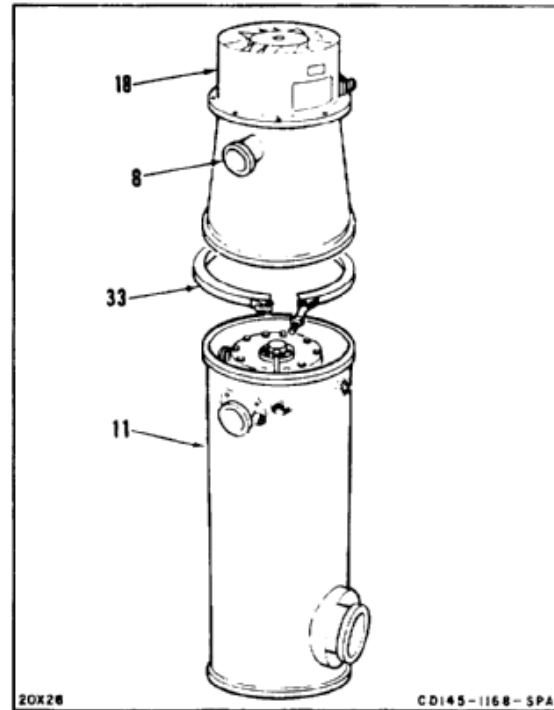

END OF TASK

## INITIAL SETUP

**Applicable Configurations:**

All

**Tools:**

Aircraft Mechanic's Tool Kit, NSN 5180-00-323-4692  
 Airframe Repairer's Tool Kit, NSN 5180-00-323-4876  
 Deep Well Socket, 1 Inch  
 Source of Compressed Air

**Materials:**

Barrier Material (E81)  
 Paper Tags (E264)  
 Masking Tape (E388)

**Personnel Required:**

Airframe Repairer  
 Medium Helicopter Repairer (2)

**Equipment Condition:**

Off Helicopter Task

1. Remove lockwire from four screws (1).
2. Remove four screws (1) holding flange (2) to jacket (3).
3. Remove flange (2), two gaskets (4), and combustion plate (5).
4. Remove lockwire and remove six pipe plugs (6).

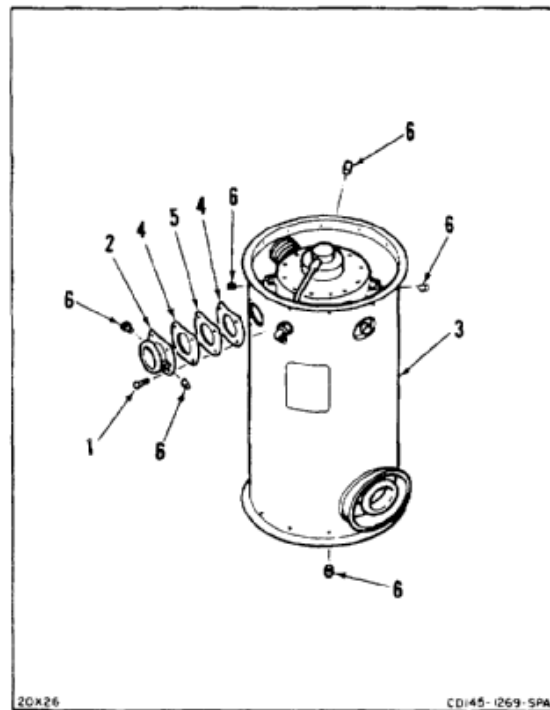

5. Remove elbow (7).
6. Remove igniter plug (8) and gasket (9).
7. Remove lockwire from seal plug (10).
8. Remove seal plug (10) and gasket (11).

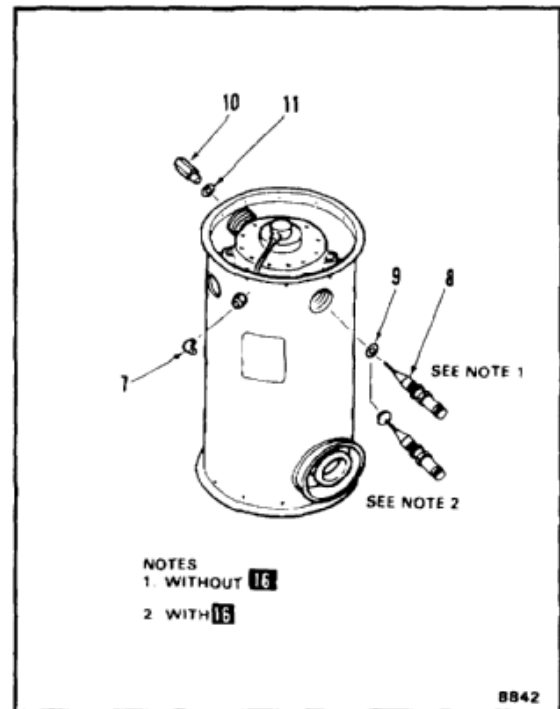

9. Remove nut (12) and washer (13) from jacket (3).
10. Scratch index mark on jacket (3) and each flange (14).
11. Cover all openings in combustion chamber (15) and jacket (3) to prevent contamination. Use barrier material (E81) and tape (E388).
12. Drill out 11 rivets (16) from each flange (14).
13. Remove upper and lower flanges (14) from jacket (3). Tag flanges.

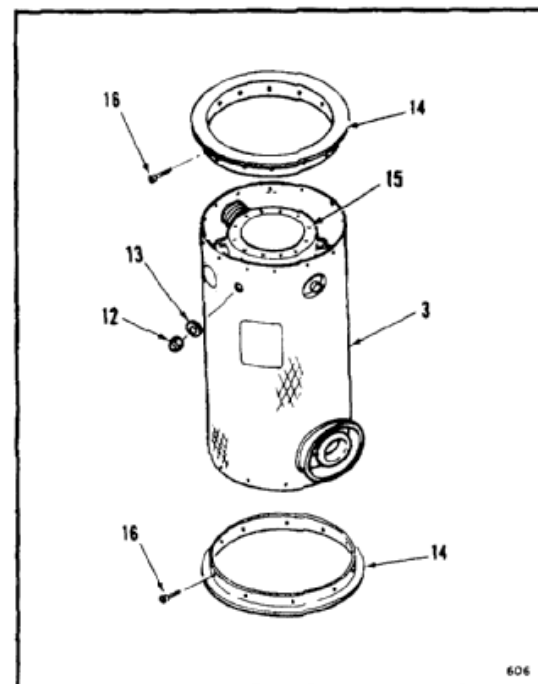

14. Remove three screws (17) and nuts (18) from jacket (3) at seam (19).

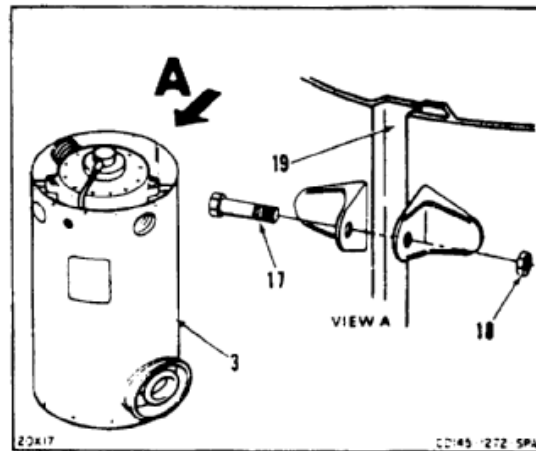

15. Spread jacket (3) enough to clear flue drain (20), air connections (21), and tube fitting (22).
16. Slide jacket (3) from combustion chamber (23). Remove gasket (4).
17. Remove asbestos rope gasket (24) from flue drain (20).
18. Remove lockwire from 4 screws (25) and 16 screws (26).

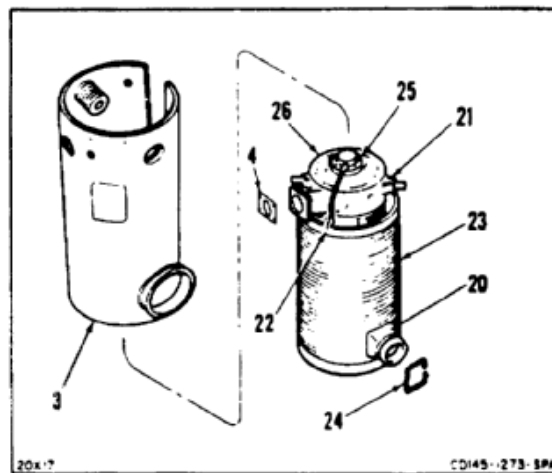

19. Remove four screws (25) and washers (27) from holder and feed assembly (28).

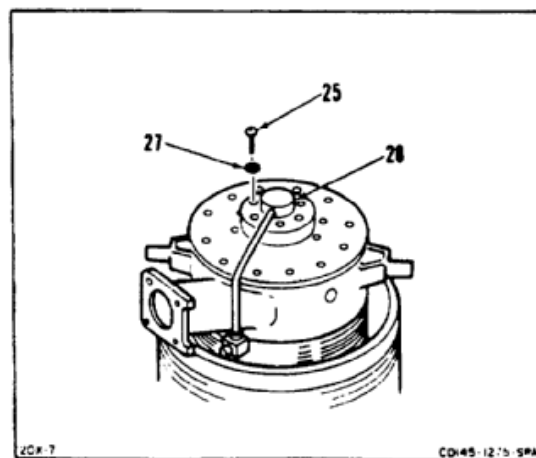

13-3 DISASSEMBLE HEATER (AVIM) (Continued)

- 20. Remove holder and feed assembly (28) and gasket (29) from combustion chamber (23).
- 21. Remove tip and strainer assembly (30) from holder and feed assembly (28).

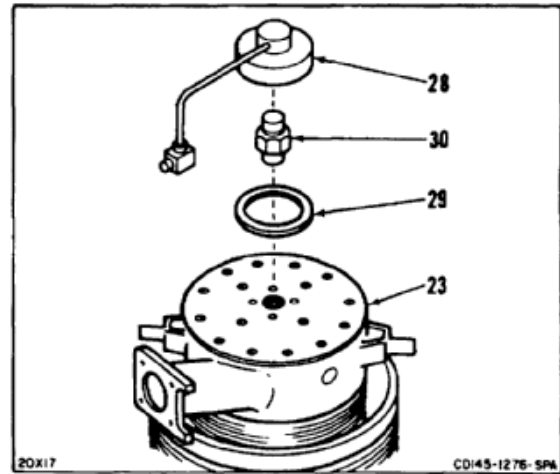

- 22. Remove 16 screws (26) and washers (31) from combustion plate (32).
- 23. Remove plate (32) and gasket (33) from combustion chamber (23).

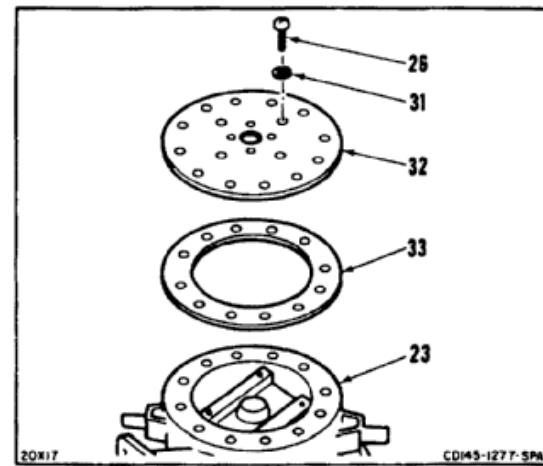

- 24. Loosen screws (34) on clamps (35).
- 25. Remove clamps (35) from thimbles (36).

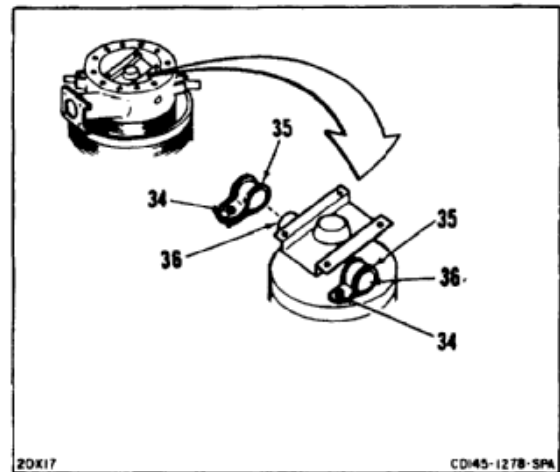

- 25.1. With **16**, remove screw (36.1) and air pick up tube (36.2).

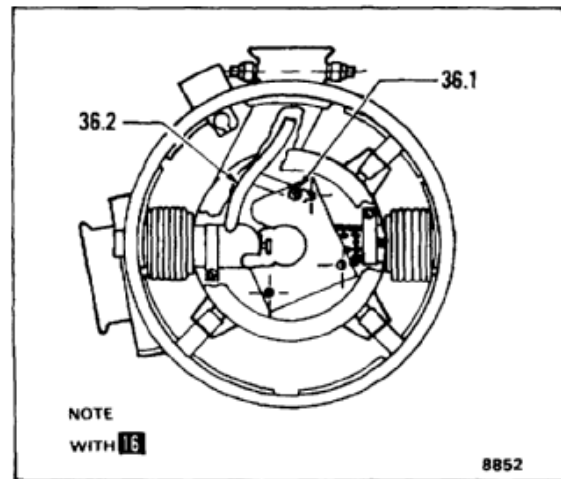

26. Slide tube and cone assembly (37) from combustion chamber (23).

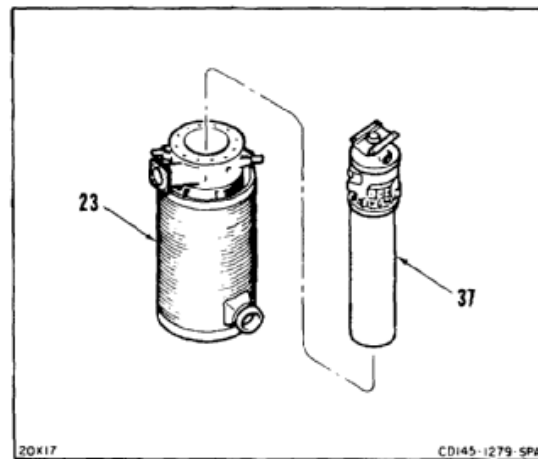

**FOLLOW-ON MAINTENANCE:**

None

END OF TASK



## INITIAL SETUP

**Applicable Configurations:**

All

**Tools:**

Aircraft Mechanic's Tool Kit, NSN 5180-00-323-4692  
 Thermometer  
 Compressed Air Source  
 Soak Tank  
 Brush, Acid Swabbing  
 Brush, Soft Bristle  
 Wire Brush, Stainless Steel  
 Source of Heat

**Materials:**

Dry Cleaning Solvent (E162)  
 Cloths (E135)  
 Oakite (E249)  
 Plastic Bag (E78)  
 Protective Clothing and Gloves  
 Gloves (E186)  
 Water

**Personnel Required:**

Medium Helicopter Repairer

**Equipment Condition:**

Off Helicopter Task  
 Heater Disassembled (Task 13-3)

**General Safety Instructions:****WARNING**

Dry cleaning solvent (E162) is flammable and toxic. It can irritate skin and cause burns. Use only in well-ventilated area away from heat and open flame. In case of contact, immediately flush skin or eyes with water for at least **15 minutes**. Get medical attention for eyes.

**CLEAN TIP AND STRAINER ASSEMBLY****CAUTION**

Tip and strainer assembly parts cannot be swapped with other tip and strainer assembly parts. Keep parts in same place during task.

1. Remove strainer (1) and two-piece core (2) from body (3). Separate core (2) from strainer (1).
2. Dip core (2), fuel strainer (1), and body (3) in dry cleaning solvent (E162). Wear goggles to protect eyes. Wear gloves (E186).

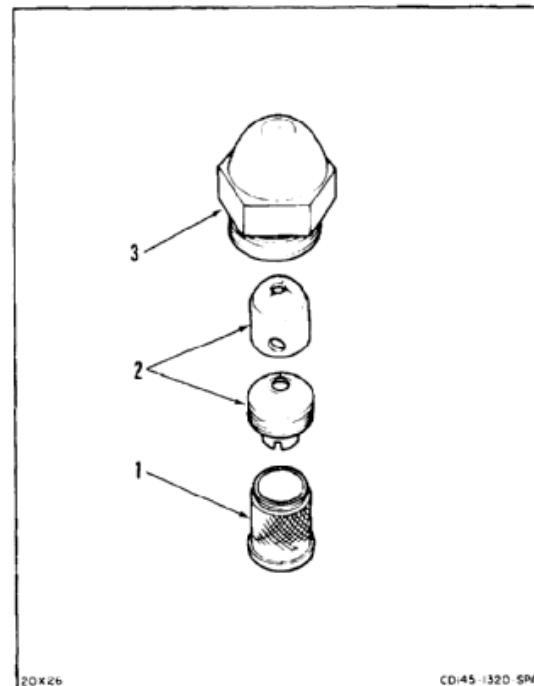

**CAUTION**

Do not scratch or deform edges of fuel channels in tip and strainer assembly parts. Damage to edges can disturb flow of fuel through parts.

3. Check body (3), core (2), and fuel strainer (1) for dirt in thread (4). Use soft bristle brush to clean thread.
4. Rinse body (3), core (2), and fuel strainer (1) in clean dry cleaning solvent (E162). Wear goggles to protect eyes. Wear gloves (E186).
5. Dry body (3), core (2), and fuel strainer (1) with low pressure, filtered, compressed air.
6. Install two-piece core (2) in body (3).

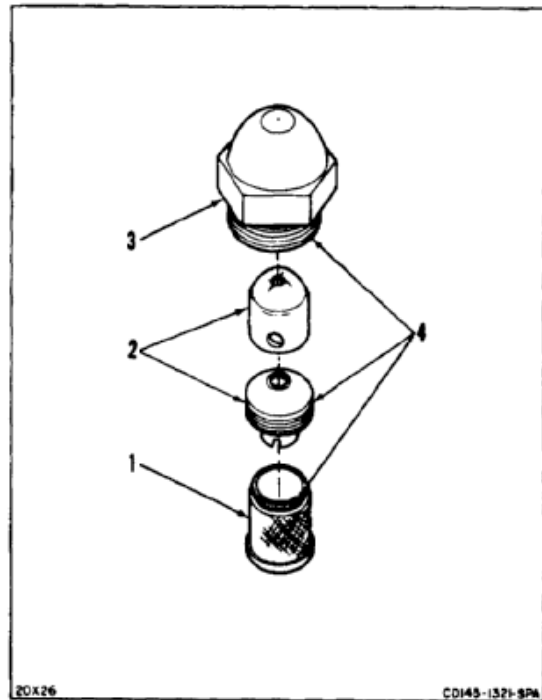

7. Install fuel strainer (1) in body (3) fingertight.

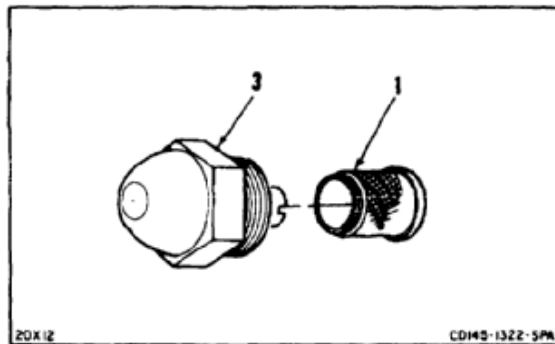

8. Place clean tip and strainer assembly (5) in plastic bag (E78) until ready to install in heater.

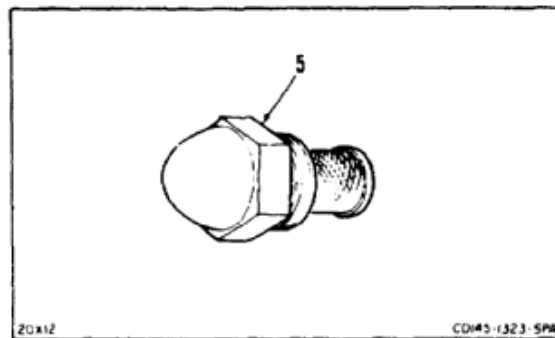

**CLEAN JACKET**

9. Remove dirt from jacket (6) with clean cloth (E135) and dry cleaning solvent (E162). Wear goggles to protect eyes. Wear gloves (E186).
10. Dry jacket (6) thoroughly with filtered compressed air.

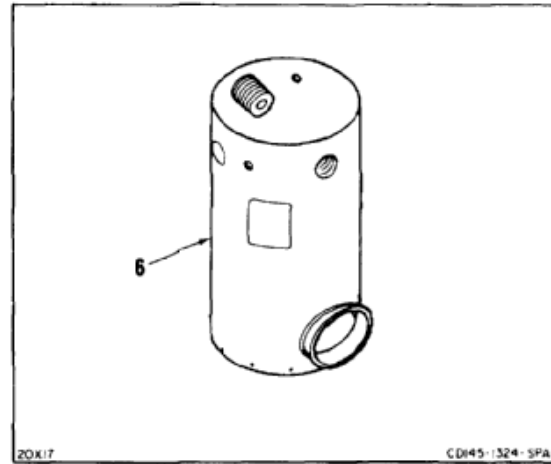

**CLEAN COMBUSTION CHAMBER AND TUBE AND CONE ASSEMBLY**



Be sure to use a stainless steel wire brush. Do not use an ordinary wire brush when cleaning parts. An ordinary wire brush can cause rusting.

**NOTE**

It is better to brush inside of combustion chamber and outside of tube and cone assembly after inspection. Brush marks can make visual inspection for cracks more difficult.

11. Clean inside and outside of combustion chamber (7) and tube and cone assembly (8) with stainless steel wire brush. Rinse away dirt with warm water.

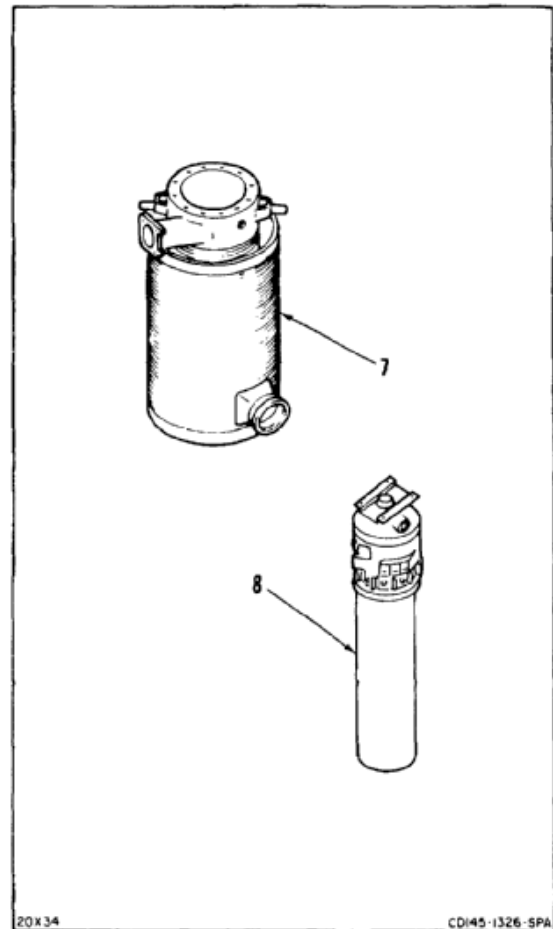

12. If required, clean combustion chamber (7) and tube and cone assembly (8) in Oakite solution as follows:

**WARNING**

Oakite (E249) can irritate skin and cause burns. Avoid contact with skin, eyes, and clothing. In case of contact, immediately flush skin or eyes with water for at least **15 minutes**. Get medical attention for eyes.

- a. Mix **1 pound** Oakite (E249) for each gallon water required to fill soak tank. Wear protective clothing and goggles. Wear gloves (E186).
- b. Heat Oakite solution to **190°F to 210°F (88°C to 99°C)**. Maintain temperature.
- c. Soak combustion chamber (7) and tube and cone assembly (8) in Oakite solution overnight.
- d. Remove combustion chamber (7) and tube and cone assembly (8) from solution. Rinse parts thoroughly in warm water.
- e. Dry combustion chamber (7) and tube and cone assembly (8) with filtered compressed air.

**FOLLOW-ON MAINTENANCE:**

None

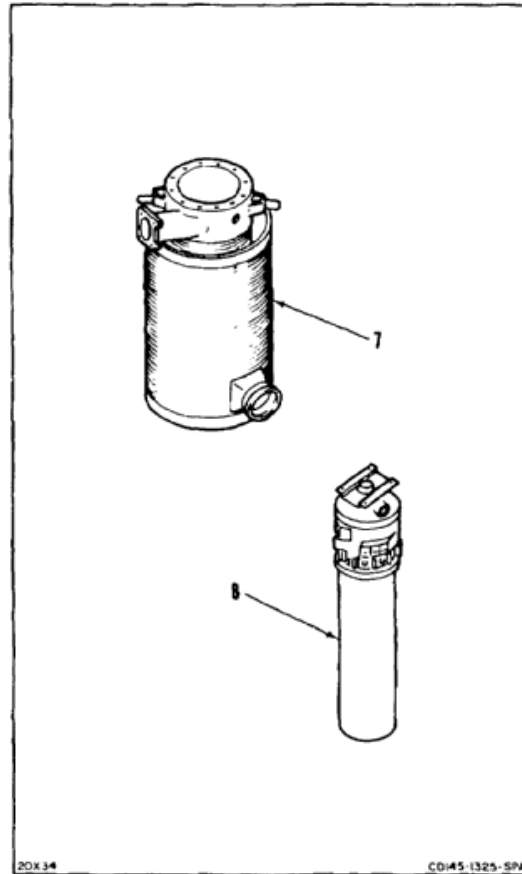

END OF TASK

## INITIAL SETUP

**Applicable Configurations:**

All

**Tools:**

Technical Inspection Tool Kit, NSN 5180-00-323-5114  
 Ballpeen Hammer  
 Compressed Air Source  
 Water Tank

**Materials:**

Acetone (E20)  
 Methyl-Ethyl-Ketone (E244)  
 Gloves (E186)

**Personnel Required:**

Medium Helicopter Repairer  
 Inspector

**References:**

TM 55-1520-240-23P  
 TM 1-1500-204-23

**Equipment Condition:**

Off Helicopter Task  
 Heater Parts Cleaned (Task 13-4)

**WARNING**

Acetone (E20) can form toxic vapors if exposed to flame. Methyl-ethyl-ketone (E244) is flammable and toxic. It can irritate skin and cause burns. Use methyl-ethyl-ketone and acetone in well-ventilated areas, away from heat and open flames. In case of contact, immediately flush skin or eyes with water for at least **15 minutes**. Get medical attention for eyes.

1. Check inside of igniter plug well (1) for signs of arcing or carbon tracks. If arcing or carbon tracks are found, clean igniter plug (2) with acetone (E20) or methyl-ethyl-ketone (E244). Wear gloves (E186).
2. Check porcelain on igniter plug (2). There shall be no cracks, breaks, or pitting.

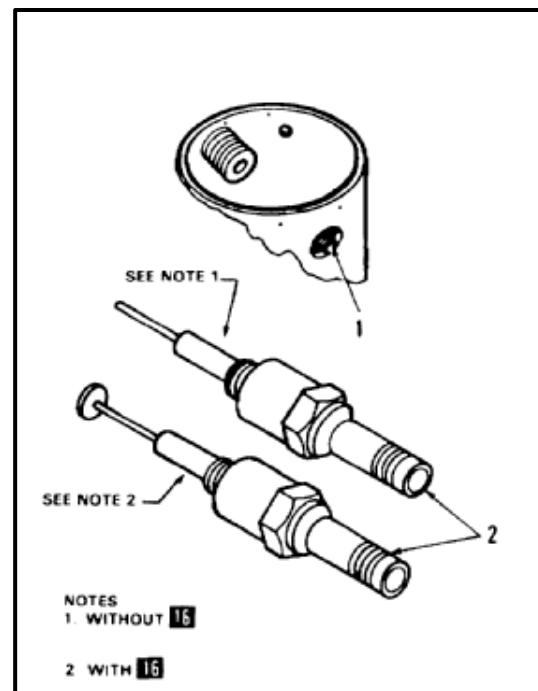

3. Check tube and cone assembly (3) for dull, dark gray areas. If dark area is found, tap area lightly with ballpeen hammer. Area shall not give soft response or dull sound.

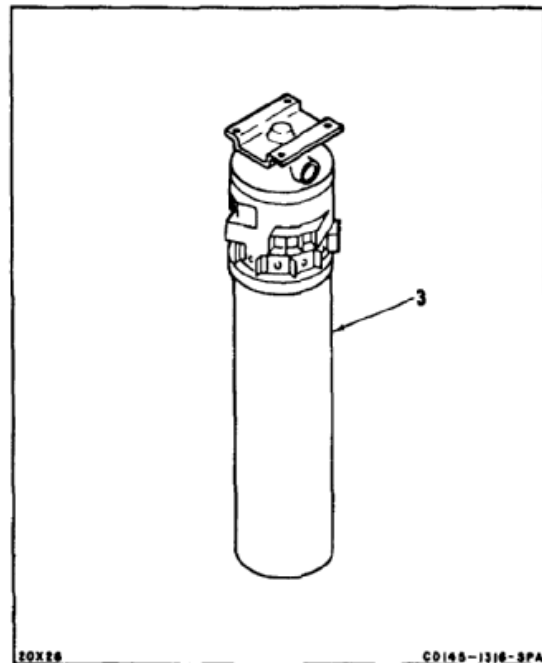

4. Position tube and cone assembly (3) inside combustion chamber (4).
5. Measure between ground electrode (5) and top of tube and cone assembly (3) with **6 inch** scale. Distance shall be **1-5/32 inches**. If not, bend ground electrode for proper distance.

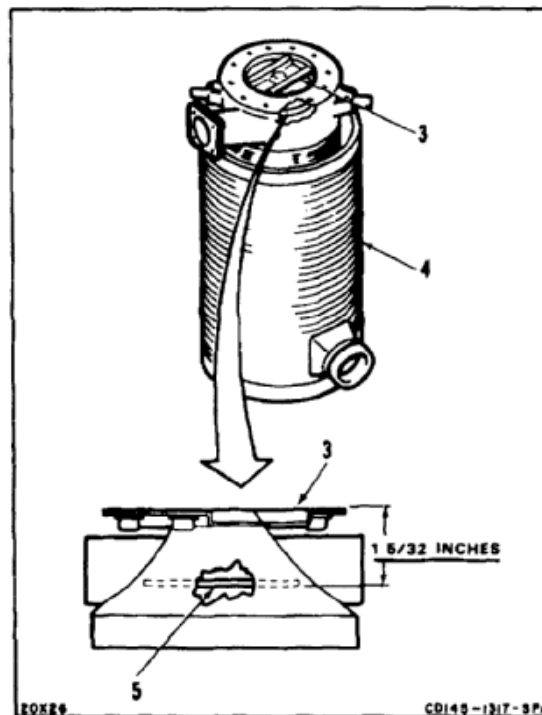

## 13-5 INSPECT HEATER PARTS (AVIM) (Continued)

13-5

6. Remove tube and cone assembly (3) from combustion chamber (4).

**NOTE**

Slight scaling and discoloration on combustion chamber are normal. Do not replace combustion chamber unless scaling or discoloration covers large area or causes distortion.

7. Tap lightly on discolored areas on combustion chamber (4) with ballpeen hammer. Area shall not give soft response or dull sound.
8. Check tube and cone assembly (3) for distortion or warping along full length of passage (6). Diameter shall not be reduced by more than **10 percent**.
9. Inspect tube and cone assembly (3) for cracks and pinholes as follows:
- Close all tube and cone assembly openings (7).
  - Pressurize tube and cone assembly (3) with air up to **6 psi**.
  - Submerge tube and cone assembly (3) in water.
  - There shall be no air bubbles.
10. Inspect all other heater parts (8) for nicks, tears, or dents that can cause leaks or affect operation of heater.

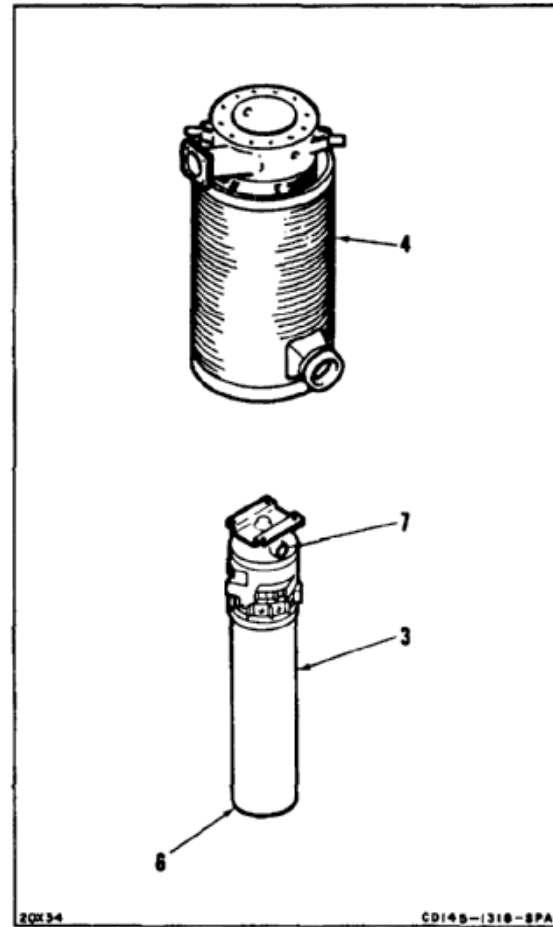
**FOLLOW-ON MAINTENANCE:**

None

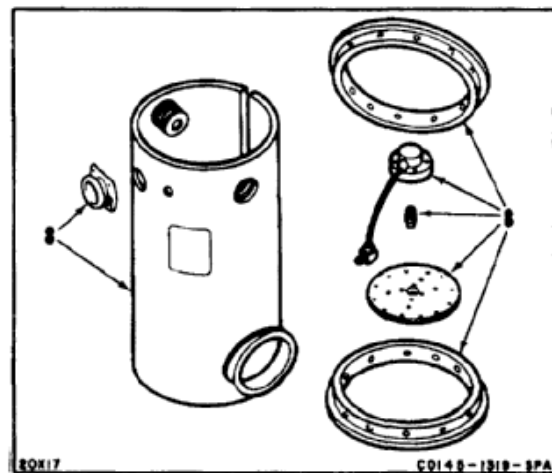

END OF TASK

## INITIAL SETUP

**Applicable Configurations:**Without **16****Tools:**

Aircraft Mechanic's Tool Kit, NSN 5180-00-323-4692  
 Airframe Repairer's Tool Kit, NSN 5180-00-323-4876  
 Torque Wrench, 30 to 150 Inch-Pounds  
 Torque Wrench, 100 to 750 Inch-Pounds  
 Feeler Gage (T63)  
 Spark Plug Thimble Gage (T62)  
 Source of Compressed Air  
 Deep Well Socket, 1 Inch

**Materials:**

Lockwire (E227)  
 Permatex (E273)  
 Gloves (E186)

1. Install tube and cone assembly (1) into combustion chamber (2). Make sure thimbles (3) align with tubes (4).

**Parts:**

Gaskets  
 Rivets

**Personnel Required:**

Airframe Repairer  
 Medium Helicopter Repairer (2)  
 Inspector

**References:**

TM 55-1520-240-23P

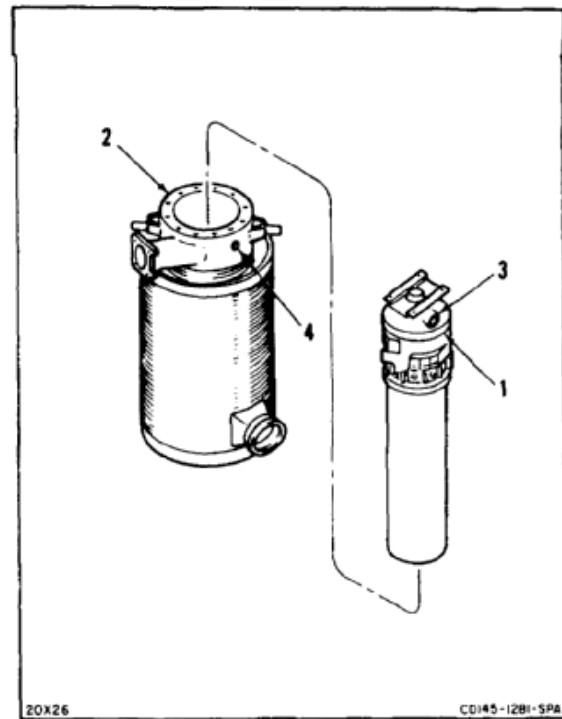



13-6 ASSEMBLE HEATER (AVIM) (Continued)

2. Install clamps (5) over thimbles (3) and tubes (4).
3. Check that ground electrode (6) is on same side of combustion chamber (2) as combustion air inlet connection (7). If not, turn tube and cone assembly (1) around to adjust.
4. Install two screws (8) in clamps (5).

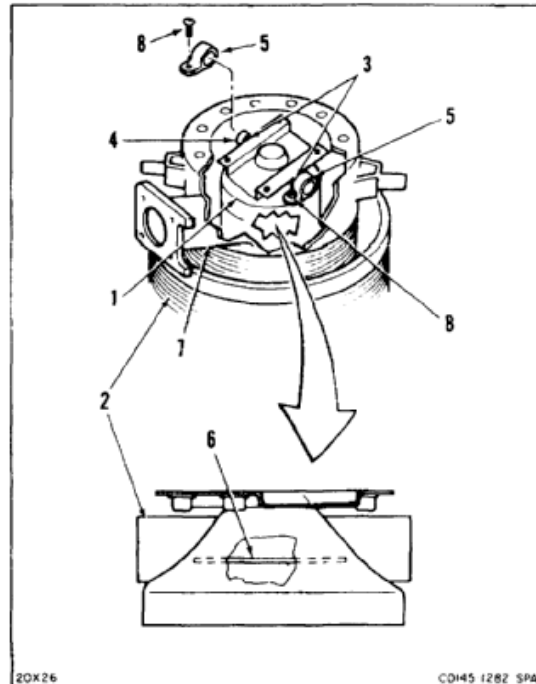

5. Install gasket (9) and combustion plate (10) on combustion chamber (2).
6. Install four screws (11) and washers (12).
7. Install 12 screws (13) and washers (14).

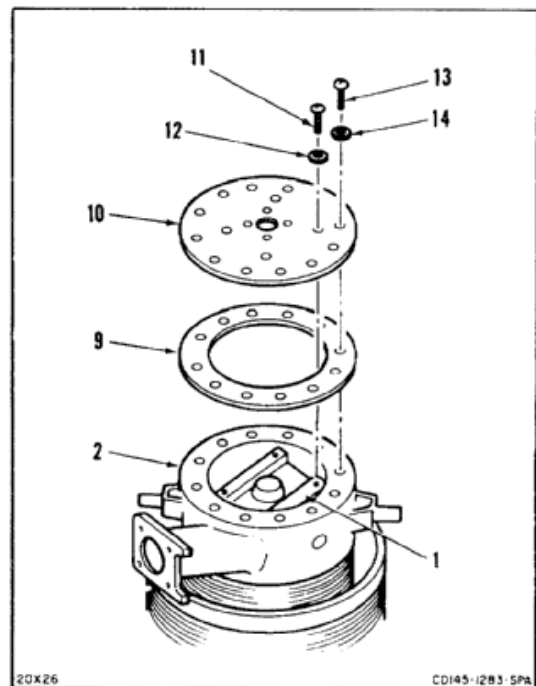

8. Install tip and strainer assembly (15) in holder and feed assembly (16).
9. Position holder and feed assembly (16) and gasket (17) on combustion plate (10). Install four screws (18) and washers (19).

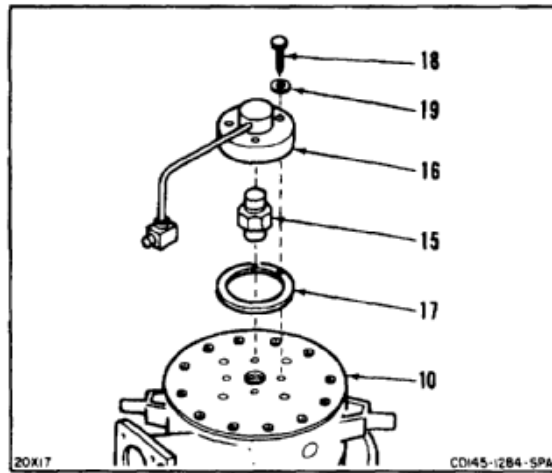

10. Lockwire four screws (18) on holder and feed assembly (16). Use lockwire (E227).
11. Lockwire 16 screws (11 and 13) on combustion plate (10). Use lockwire (E227).

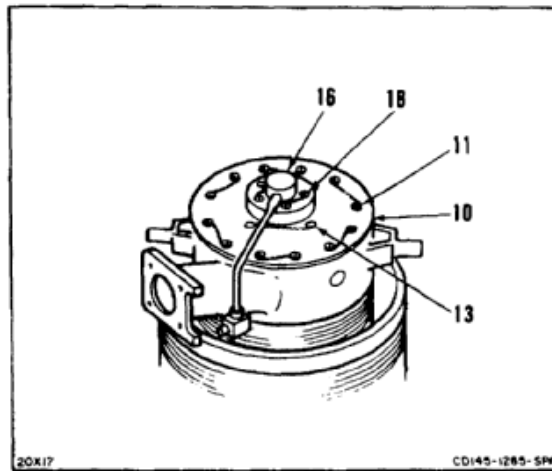

12. Install rope gasket (20) on flue drain (21).

**WARNING**

Permatex (E273) is flammable and toxic. It can irritate skin and cause burns. Use only in well-ventilated area, away from heat and open flame. In case of contact, immediately flush skin or eyes with water for at least **15 minutes**. Get medical attention for eyes.

13. Apply coat of Permatex (E273) to both sides of gasket (22). Wear gloves (E186).
14. Position gasket (22) on combustion air connection (23).
15. Spread jacket (24) just enough to slide jacket over flue drain (21) and air connections (23).
16. Slide jacket (24) over combustion chamber (2).

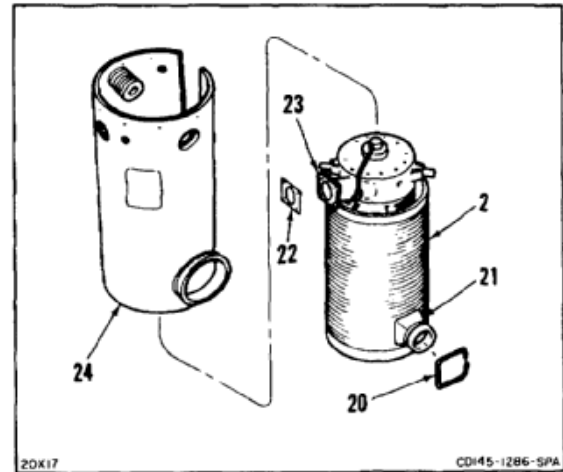

17. Insert jacket tongue (25) in self-locking groove (26) of jacket seam (27).
18. Install three screws (28) and nuts (29) in jacket seam (27) to secure jacket (24). Do not tighten screws at this time.
19. Install flange (30), two gaskets (31), and combustion plate (32) on jacket (24). Install four screws (33). Lockwire screws. Use lockwire (E227).
20. Tighten screws (28) and nuts (29) in jacket seam (27).

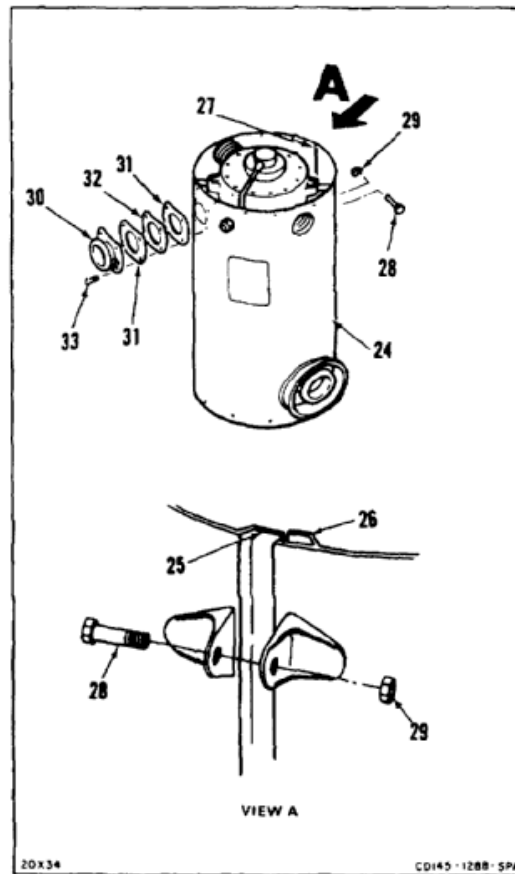

**CAUTION**

If new flange is to be installed, cover all openings in combustion chamber and jacket before drilling to prevent contamination.

21. Remove tags and install upper and lower flanges (34) on jacket (24). If flange is new, make sure face of flange is square with jacket within **0.03 inch**. Then drill holes through flange to match holes in jacket.
22. Align index marks on flange (34) with marks on jacket (24).
23. Install 11 rivets (35) in each flange (34).

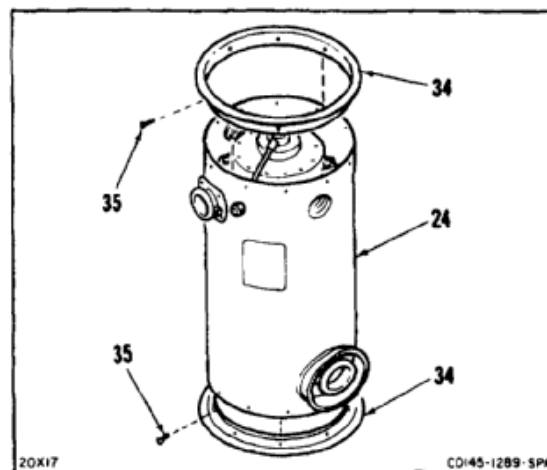

**CAUTION**

Damage to holder and feed assembly can result if fuel tube turns when washer and nut are installed.

- 24. Hold square fitting (36) under jacket (24) firmly. Install washer (37) and nut (38). Do not allow tube (39) to turn.

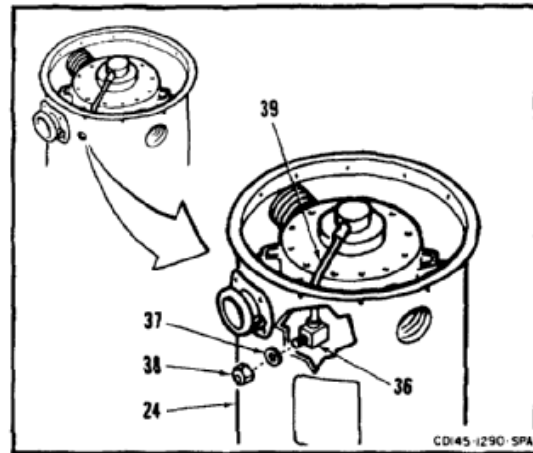

- 25. Install seal plug (40) and gasket (41).

**WARNING**

Fire can result if plugs are not torqued and lockwired.

- 26. Torque seal plug (40) to **335 inch-pounds**.
- 27. Install five pipe plugs (42).
- 28. Torque each pipe plug (42) to **150 inch-pounds**.

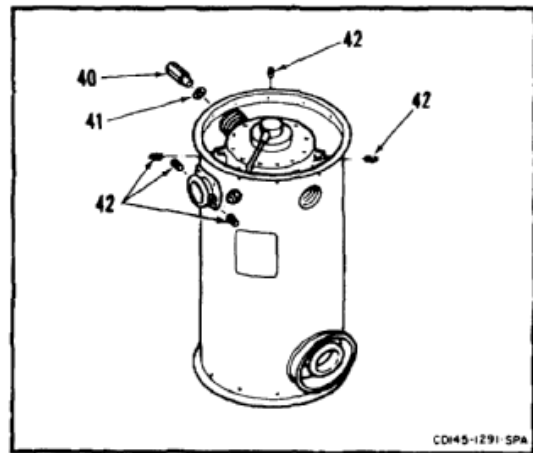

- 29. Lockwire five pipe plugs (42) and seal plug (40). Use lockwire (E227).
- 30. Install elbow (43) in nut (38).
- 31. Install pipe plug (44) in bottom of heater (45).

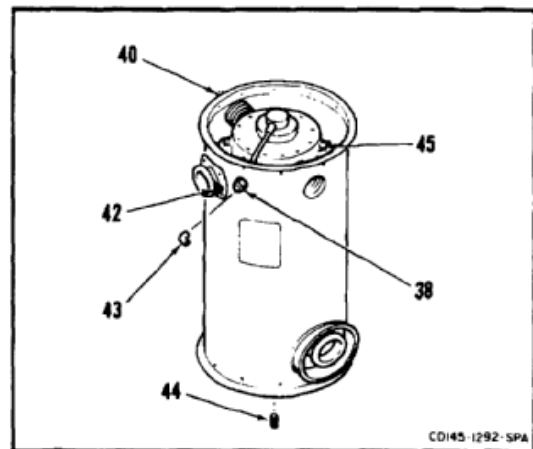

32. Install feeler gage (T63) (48) in spark plug thimble gage (T62) (47).

**NOTE**

Make sure point of feeler gage is inside heater when thimble gage is installed.

33. Install thimble gage (T62) (47) in spark plug thimble (48) of spark plug well (49).

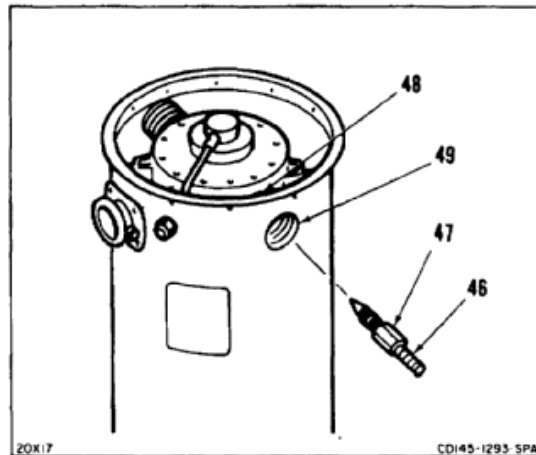

34. Push feeler gage (T63) (46) into thimble gage (T62) (47) until gage contacts ground electrode (6).

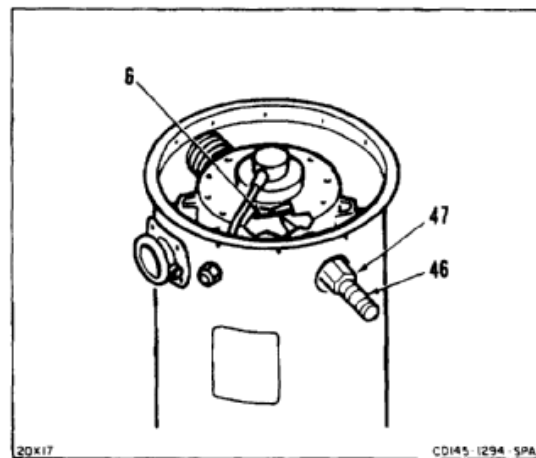

**13-6 ASSEMBLE HEATER (AVIM) (Continued)**

13-6

35. Check mark on end of feeler gage (T63) (46). Gage shall read within limits of area B (50). If not, reset spark gap as follows:
- Pull feeler gage (T63) (46) out until gage is free of ground electrode (6). Make sure tapered end of feeler gage (T63) is bottomed against thimble gage (47).
  - Pivot feeler gage (T63) (46) and bend spark plug thimble (T62) (47) to obtain proper spark gap. Turn feeler gage (T63) to increase or decrease spark gap.
  - When proper spark gap is obtained, push feeler gage (T63) (46) into thimble gage (T62) (47) until feeler gage contacts ground electrode (6).
36. Repeat step 35.
37. Remove feeler gage (T63) (46) and thimble gage (T62) (47) from heater (45).



Make sure thimble gage reading is within limits of area B before installing igniter plug. If gage does not read in area B, igniter plug will not be installed in correct position.

38. Install igniter plug (51) and gasket (52).
39. Torque igniter plug (51) to **335 inch-pounds**.

**INSPECT****FOLLOW-ON MAINTENANCE:**

Perform operational check (TM 55-1520-240-T).

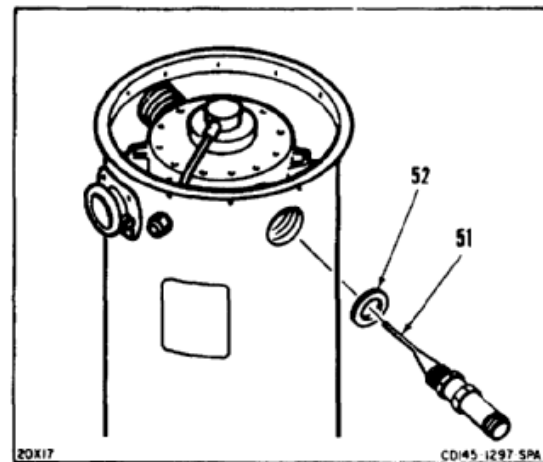
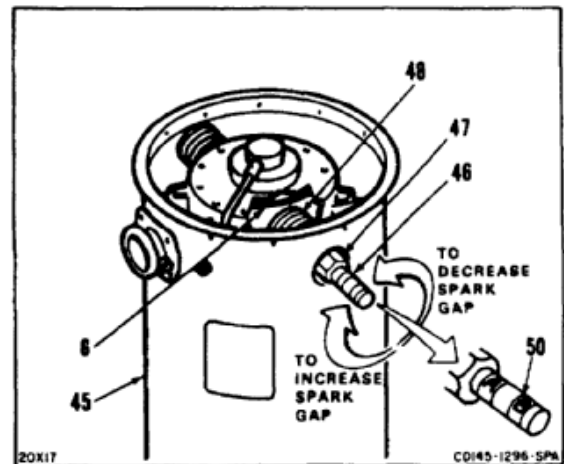

END OF TASK

## INITIAL SETUP

**Applicable Configurations:**

With **16**

**Tools:**

Aircraft Mechanic's Tool Kit, NSN 5180-00-323-4692  
 Airframe Repairer's Tool Kit, NSN 5180-00-323-4876  
 Torque Wrench, 30 to 150 Inch-Pounds  
 Torque Wrench, 100 to 750 Inch-Pounds  
 Source of Compressed Air  
 Deep Well Socket, 1 Inch  
 Ignition Assembly 11C30-1 or -1M  
 Wire Feeler Gage, 0.015 to 0.018 Inch

**Materials:**

Lockwire (E227)  
 Lockwire (E230)  
 Permatex (E273)  
 Gloves (E186)

**Parts:**

Gaskets  
 Rivets

**Personnel Required:**

Airframe Repairer  
 Medium Helicopter Repairer  
 Inspector

**References:**

TM 55-1520-240-23P

1. Install tube and cone assembly (1) into combustion chamber (2). Make sure thimbles (3) align with tubes (4).

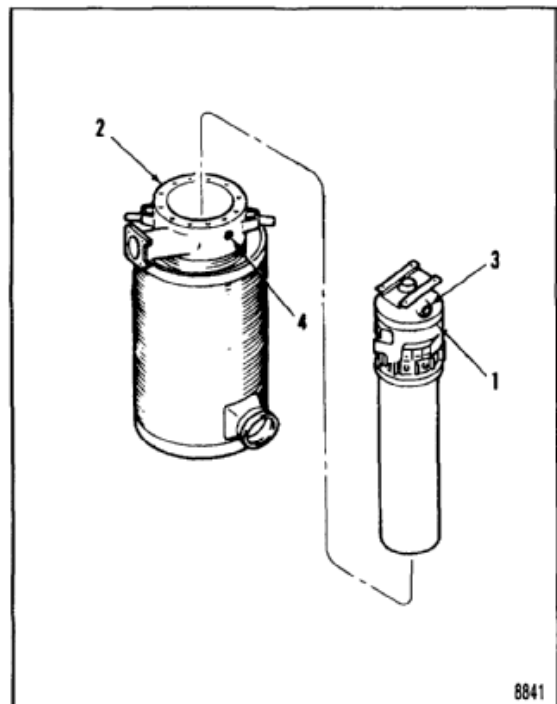



**13-6.1 ASSEMBLE HEATER (AVIM) (Continued)**

13-6.1

- 1.1. Install air pickup tube (4.1) in combustion air duct (4.2).
- 1.2. Tighten screw (4.3). Check that air pickup tube is inserted into spark plug shroud (4.4) at least **0.06 inch**.

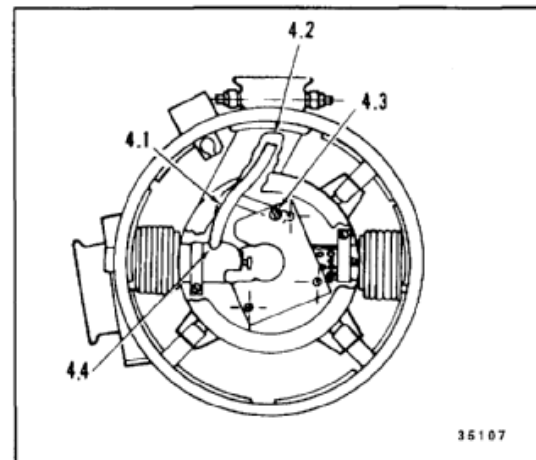

2. Install clamps (5) over thimbles (3) and tubes (4).
3. Install two screws (6) in clamps (5).

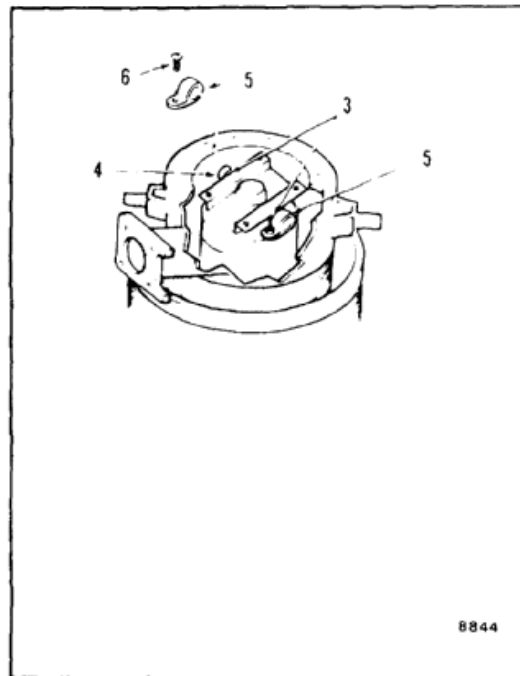

4. Install gasket (7) and combustion plate (8) on combustion chamber (2).
5. Install four screws (9) and washers (10).
6. Install 12 screws (11) and washers (12).

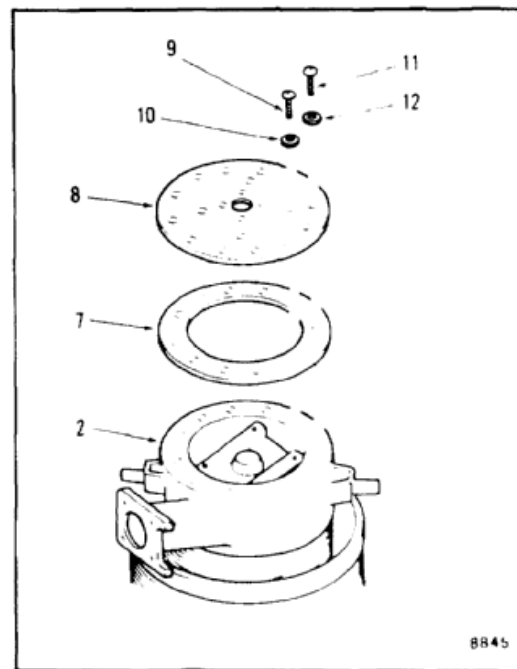

7. Install igniter plug (13) and washer (14).
8. Torque igniter plug (13) to **335 inch-pounds**.

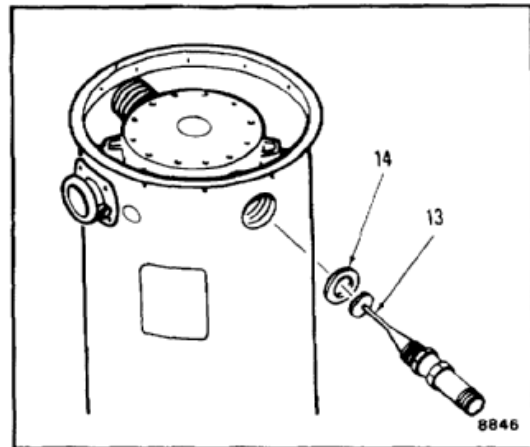

9. Check the spark gap using a wire feeler gage thru the nozzle opening (16) in the combustion plate. The gap is **0.15 to 0.18 inch**.



Use care when adjusting concentricity with screwdriver to prevent damage to spark plug ceramic.

10. Check the concentricity of the igniter plug (13) and the shroud (15) by viewing the end of the igniter plug thru the opposite igniter plug port (17). If concentricity is satisfactory, go to step 11. If adjustment of concentricity is required, remove igniter plug, insert a **one-half inch** rod (18) through opposite igniter plug port (17) into end of shroud (15) and adjust shroud by bending.

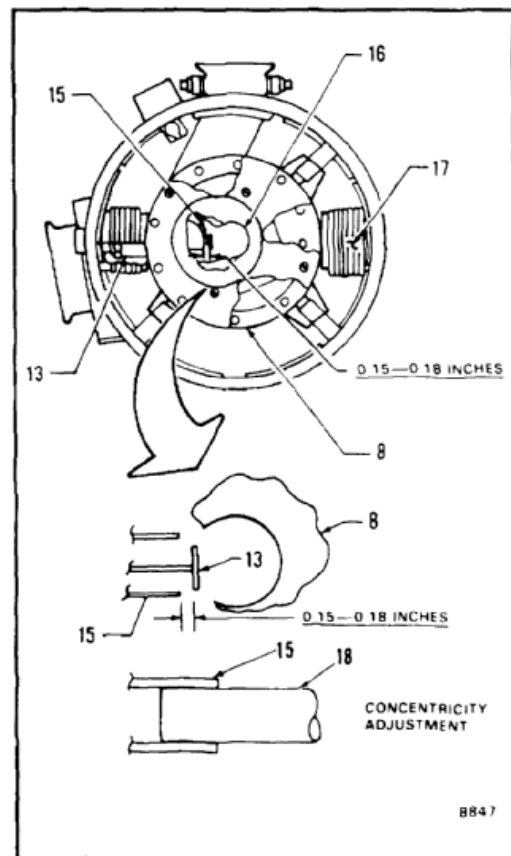

**WARNING**

Dangerous voltages at igniter plug arcing from the igniter plug to the shroud can cause serious burns.

11. Connect **28 vdc** power supply (19) to ignition unit (20).
12. Connect shielded lead (21) to igniter plug in heater (22).
13. Energize **28 vdc** power supply.
  
14. Observe the igniter plug arcing thru the fuel opening in the combustion plate (8).
15. Arcing (23) should be between the button end of the igniter plug (13) and shroud end (15).
16. There should be no arcing (23) internally in the shroud (15).
17. If internal arcing occurs, shut down and return to step 10.
18. Energize the system per step 13 and observe arcing.
19. Shut down system and disconnect power source (19).

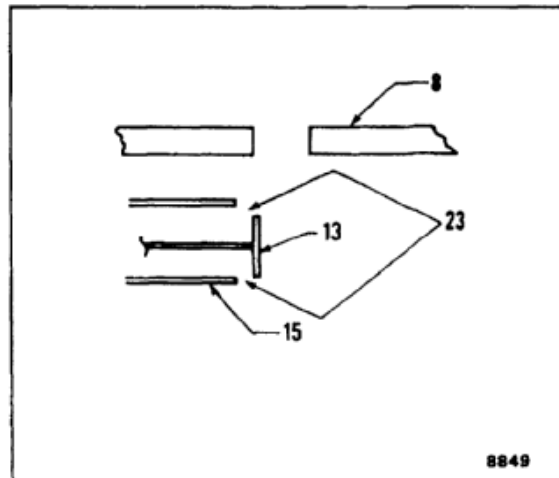
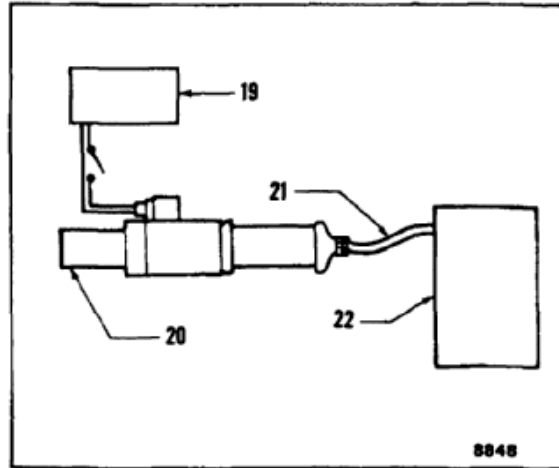

## 13-6.1 ASSEMBLE HEATER (AVIM) (Continued)

13-6.1

20. Install tip and strainer assembly (24) in holder and feed assembly (25).
21. Position holder and feed assembly (25) and gasket (26) on combustion plate (8). Install four screws (27) and washers (28).

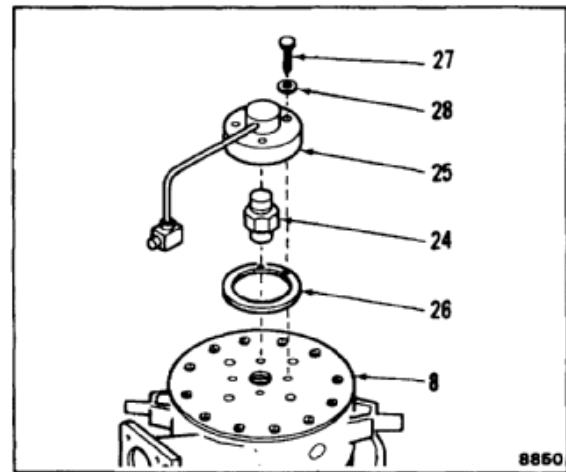

22. Lockwire four screws (27) on holder and feed assembly (25). Use lockwire (E230).
23. Lockwire 16 screws (11 and 13) on combustion plate (8). Use lockwire (E230).

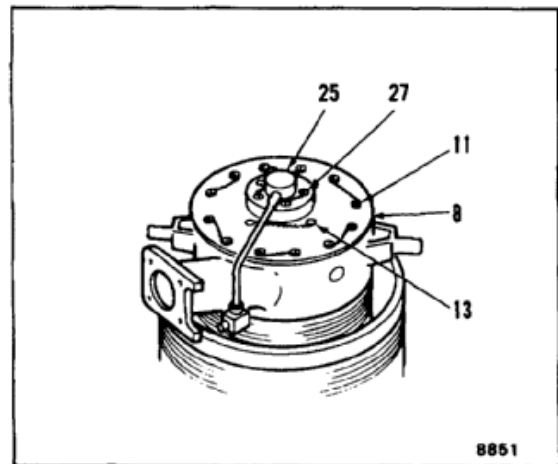

24. Install rope gasket (29) on flue drain (30).

**WARNING**

Permatex (E273) is flammable and toxic. It can irritate skin and cause burns. Use only in well-ventilated area, away from heat and open flame. In case of contact, immediately flush skin or eyes with water for at least **15 minutes**. Get medical attention for eyes.

25. Apply coat of Permatex (E273) to both sides of gasket (31). Wear gloves (E186).
26. Position gasket (31) on combustion air connection (32).
27. Spread jacket (33) just enough to slide jacket over flue drain (30) and air connections (32).
28. Slide jacket (33) over combustion chamber (2).

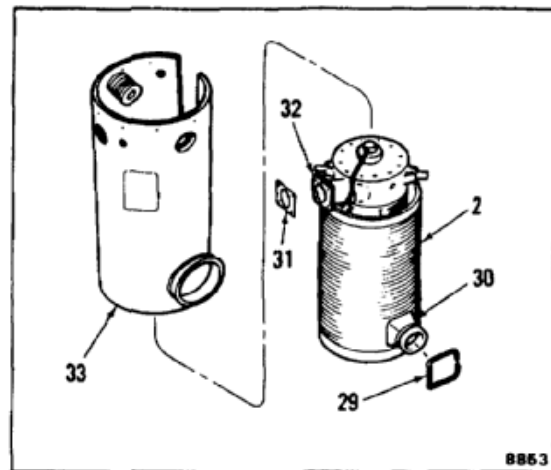

13-6.1 ASSEMBLE HEATER (AVIM) (Continued)

13-6.1

29. Insert jacket tongue (34) in self-locking groove (35) of jacket seam (36).
30. Install three screws (37) and nuts (38) in jacket seam (36) to secure jacket (33). Do not tighten screws at this time.
31. Install flange (39), two gaskets (40), and combustion plate (41) on jacket (33). Install four screws (42). Lockwire screws. Use lockwire (E230).
32. Tighten screws (37) and nuts (38) in jacket seam (36).

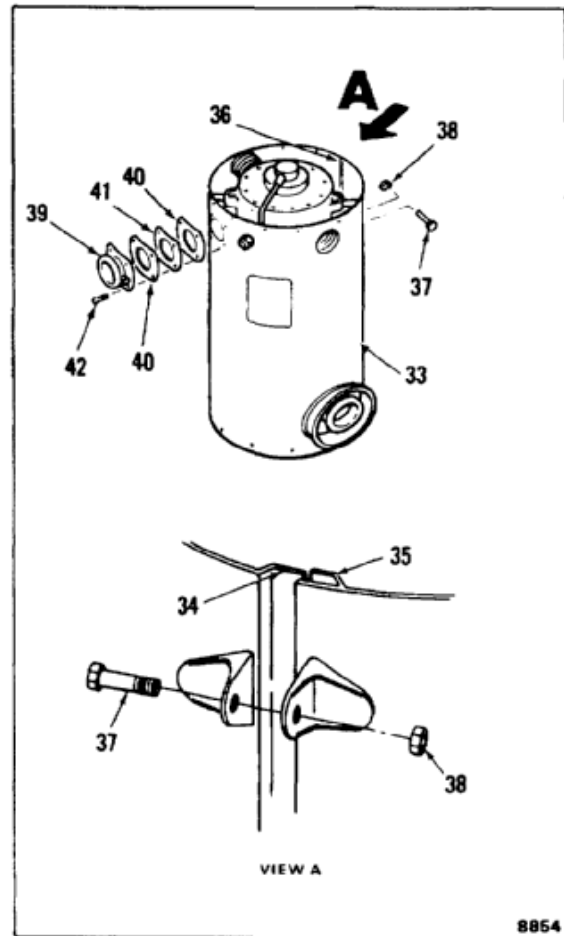

**CAUTION**

If new flange is to be installed, cover all openings in combustion chamber and jacket before drilling to prevent contamination.

33. Remove tags and install upper and lower flanges (43) on jacket (33). If flange is new, make sure face of flange is square with jacket within **0.03 inch**. Then drill holes through flange to match holes in jacket.
34. Align index marks on flange (43) with marks on jacket (33).
35. Install 11 rivets (44) in each flange (43).

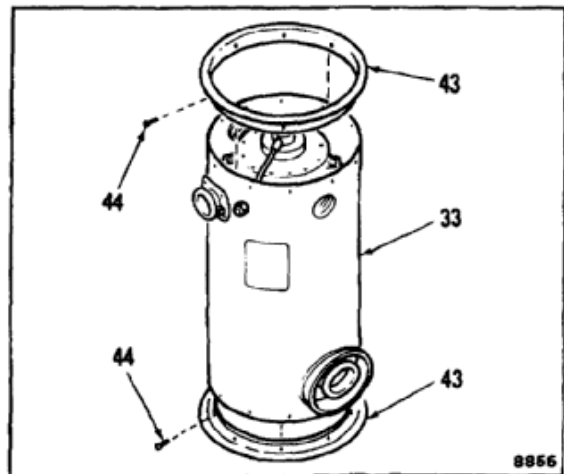

**CAUTION**

Damage to holder and feed assembly can result if fuel feed tube turns when washer and nut are installed.

36. Hold square fitting (45) under jacket (33) firmly. Install washer (46) and nut (47). Do not allow tube (48) to turn.

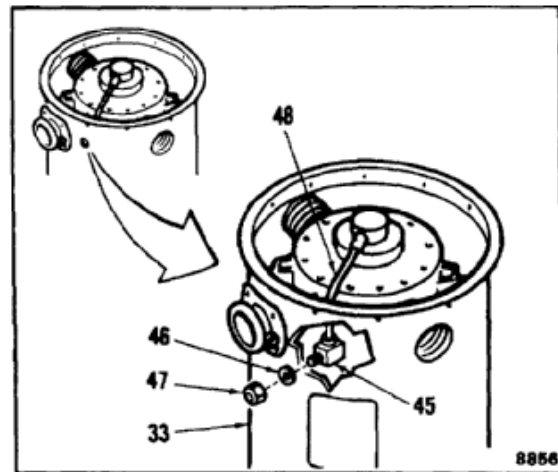

37. Install seal plug (49) and gasket (50).

**WARNING**

Fire can result if plugs are not torqued and lockwired.

38. Torque seal plug (49) to **335 inch-pounds**.
39. Install five pipe plugs (51).
40. Torque each pipe plug (51) to **150 inch-pounds**.

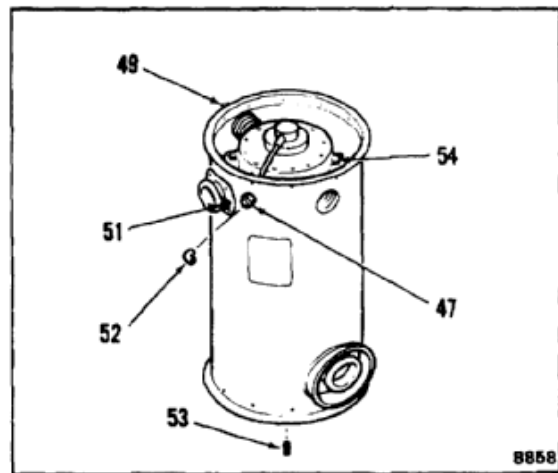

41. Lockwire five pipe plugs (51) and seal plug (49). Use lockwire (E227).
42. Install protective plug (52) in nut (47).
43. Install pipe plug (53) in bottom of heater (54).

**INSPECT**

**FOLLOW-ON MAINTENANCE:**

Perform operational check (TM 55-1520-240-T).

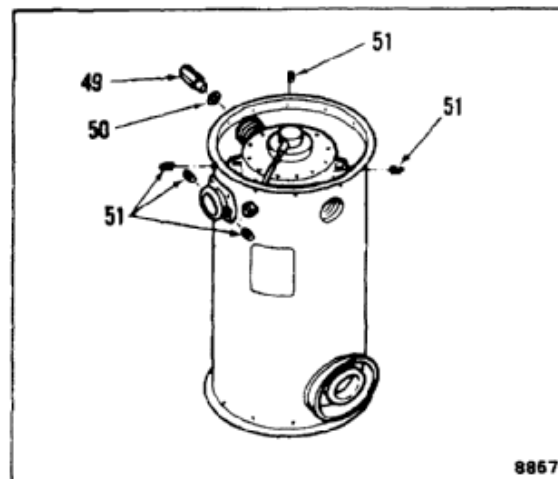

END OF TASK



## INITIAL SETUP

**Applicable Configurations:**

All

**Tools:**

Mercury Manometer 30PGTM, 30 Inch  
Source of Low Pressure Compressed Air

1. Connect mercury manometer (1) in parallel to compressed air source (2).
2. Connect air source (2) to heater drain fitting (3).
3. Plug all other openings (4) in heater (5).
4. Adjust air source (2) to pressure of **12 inches** of mercury.
5. Shut off air source (2).
6. Read mercury manometer (1). Pressure shall not drop **1.0 inch** within **90 seconds**.
7. Release pressure and disconnect air source (2) from heater drain fitting (3).

**FOLLOW-ON MAINTENANCE:**

None

**Materials:**

None

**Personnel Required:**

Medium Helicopter Repairer

**Equipment Condition:**

Off Helicopter Task

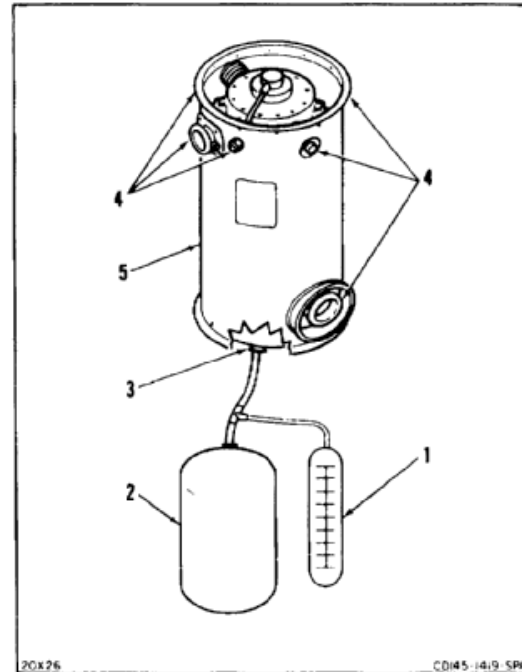

END OF TASK

INITIAL SETUP

**Applicable Configurations:**

All

**Tools:**

Aircraft Mechanic's Tool Kit, NSN 5180-00-323-4692  
 Torque Wrench, 0 to 30 Inch-Pounds  
 Torque Wrench, 30 to 150 Inch-Pounds

**Materials:**

Acetone (E20)  
 Lockwire (E231)  
 Gloves (E184.1)

**Parts:**

Heater Duct Seal

**Personnel Required:**

Medium Helicopter Repairer (2)  
 Inspector

**References:**

TM 55-1520-240-23 P

1. Position adapter (1) and fan (2) on heater (3).
2. Install clamp (4) on adapter (1) and heater (3).
- 2.1. Torque clamp (4) to **60 inch-pounds**.

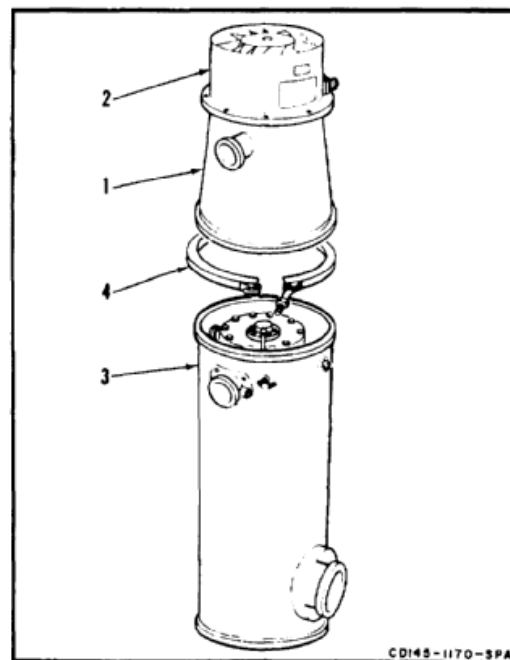
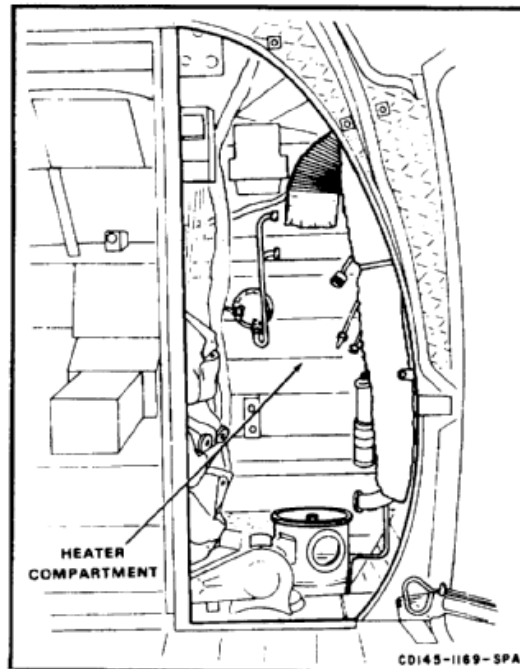

**13-8 INSTALL HEATER (Continued)**

3. Lockwire clamp (4). Use lockwire (E231).
4. Install combustion tube (5) and two clamps (6) on adapter (1) and heater (3).

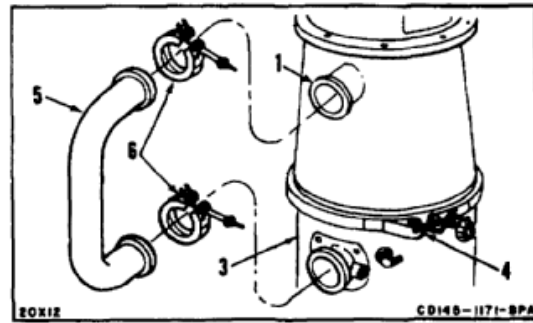

5. Torque clamps (6) to **40 inch-pounds**.
6. Lockwire clamps (6). Use lockwire (E231).

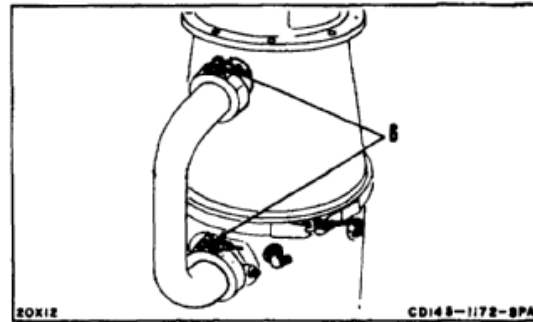

7. Position heater (3), adapter (1), and fan (2) on transition duct (7) so flue drain (8) aligns with exhaust pipe (9).
8. Slide air inlet duct (10) on fan (2).

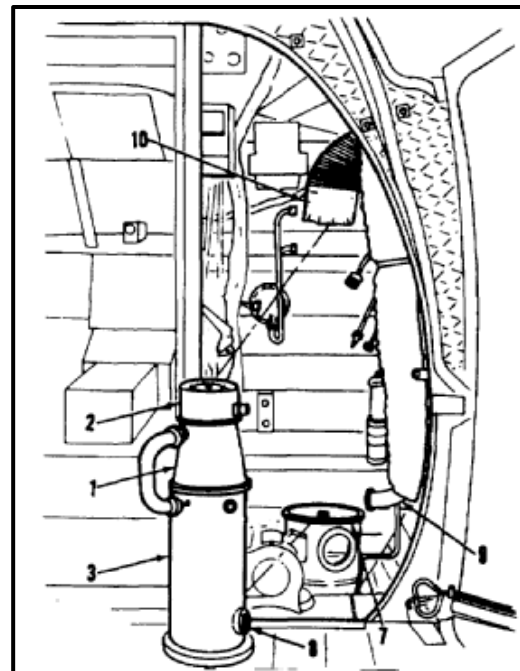

- 9. Install clamp (11) on heater (3) and transition duct (7).
- 9.1. Torque clamp (11) to **60 inch-pounds**.

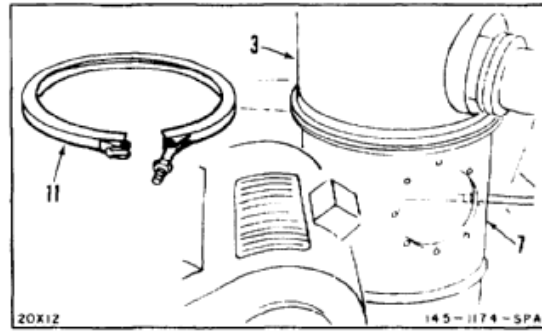

- 10. Lockwire clamp (11). Use lockwire (E231).
- 11. Connect drain tube (12) at heater connection (13) inside transition duct (7).

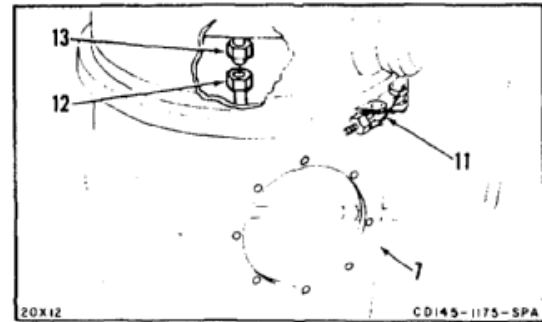

- 12. Install seal (14), access cover (15), eight washers (16), and eight screws (17).

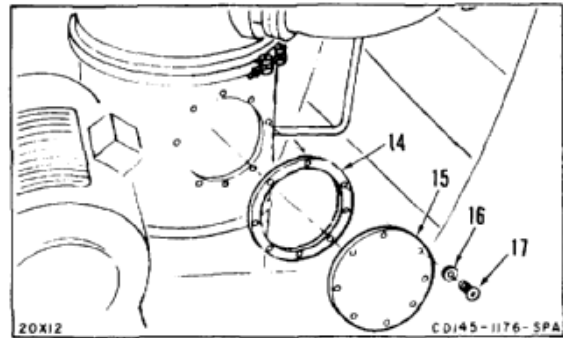

- 13. Install clamp (18) on flue drain (8) and exhaust pipe (9).

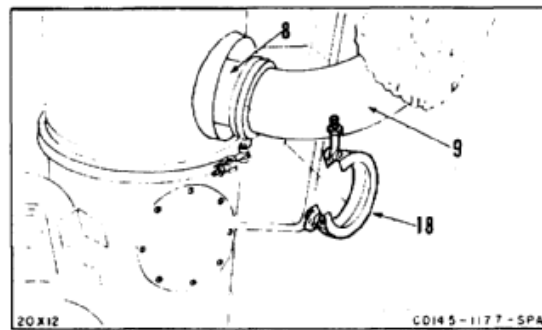

- 14. Lockwire clamp (18). Use lockwire (E231).

**INSPECT**

- 15. Install exhaust shroud elbow halves (19) on pipe (9).

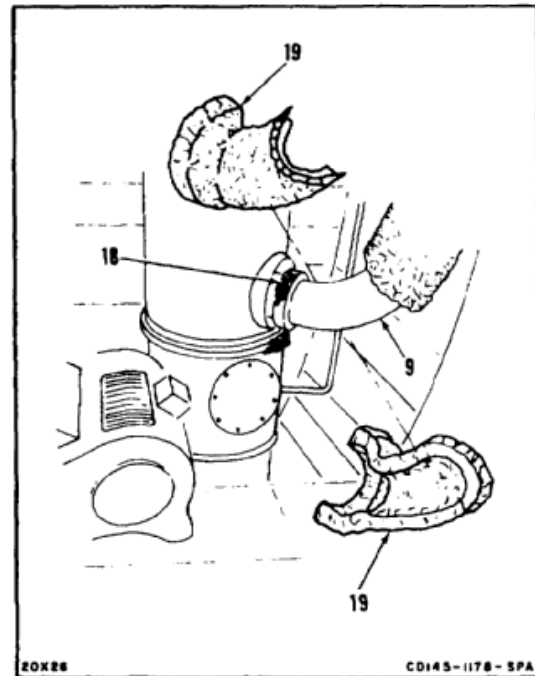

- 16. Lacewire shroud elbows (19) together. Use lockwire (E231).

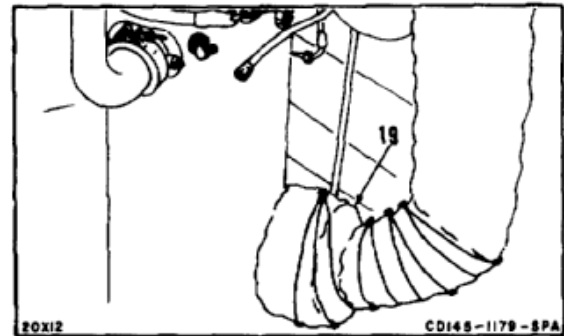

- 17. Install clamps (20) on air inlet duct (10).
- 18. Connect electrical connector (21) to fan (2).

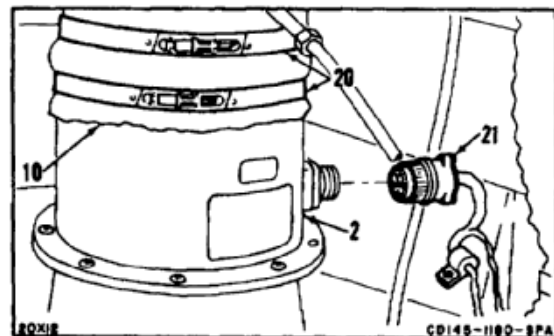

19. Lockwire electrical connector (21). Use lockwire (E231).
20. Install screw (22), two washers (23), clamp (24), wires (25), and nut (26) through fan (2).

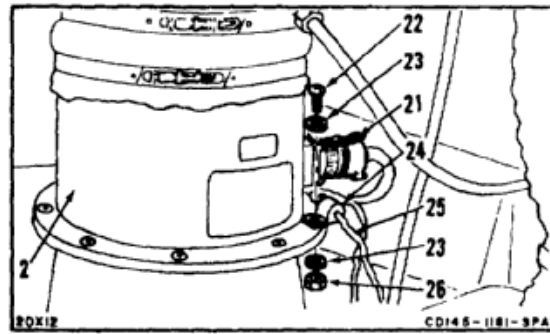

21. Turn low pressure tube (27) and high pressure tube (28) toward heater (3).
22. Connect low pressure tube (27) to air inlet duct (10).
23. Connect high pressure tube (28) to adapter (1).
24. Tighten nuts (29) on air pressure switch (30).

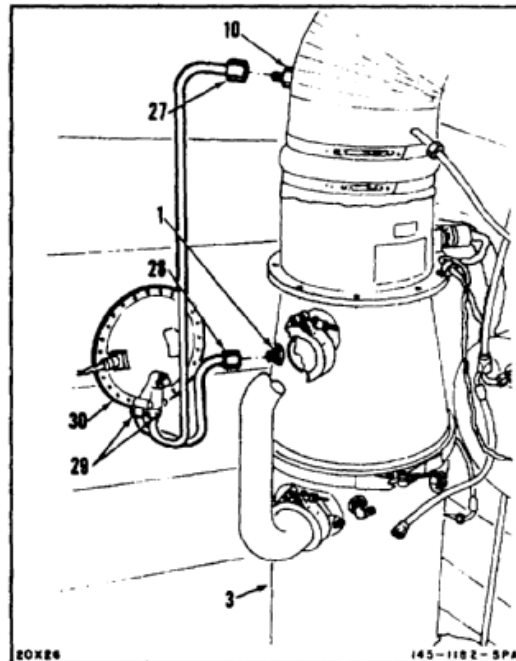

**13-8 INSTALL HEATER (Continued)**

13-8

25. Remove caps from fuel tube (31) and elbow (32).

**WARNING**

Acetone (E20) can form toxic vapors if exposed to flame. Use acetone in well-ventilated areas, away from heat and open flames. In case of contact, immediately flush skin or eyes with water for at least **15 minutes**. Get medical attention for eyes.

26. Clean shielded lead (33) with acetone (E20). Connect shielded lead to spark igniter (34). Wear gloves (E184.1).
27. Remove plug and connect fuel tube (31) to elbow (32).

**FOLLOW-ON MAINTENANCE:**

Check operation of heater (TM 55-1520-240-T).  
Install acoustical blanket (Task 2-210).

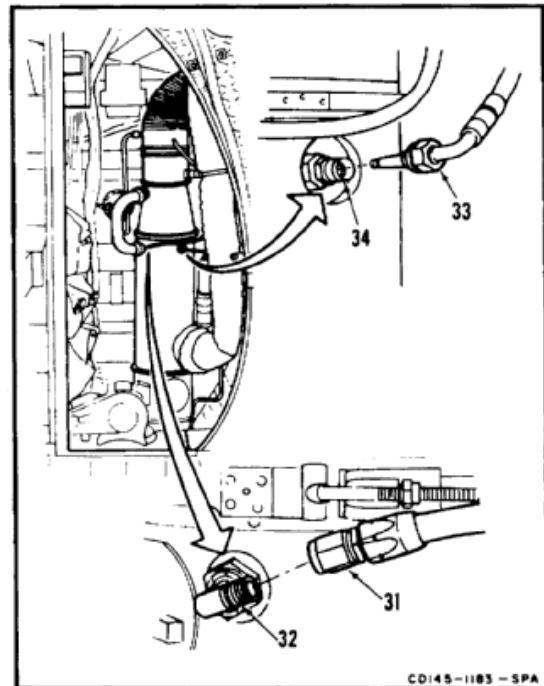

END OF TASK

## INITIAL SETUP

**Applicable Configurations:**

All

**Tools:**

Aircraft Mechanic's Tool Kit, NSN 5180-00-323-4692  
Source of Dry Compressed Air

**Materials:**

Dry Cleaning Solvent (E161)  
Gloves (E186)

**Personnel Required:**

Medium Helicopter Repairer  
Inspector

**Equipment Condition:**

Battery Disconnected (Task 1-39)  
Electrical Power Off  
Hydraulic Power Off  
Heater Compartment Acoustics Blanket Removed  
(Task 2-208)

**General Safety Instructions:****WARNING**

Dry cleaning solvent (E161) is combustible and toxic. It can irritate skin and cause burns. Use only with adequate ventilation, away from open flame. In case of contact, immediately flush skin or eyes with water for at least **15 minutes**. Get medical attention for eyes.

**WARNING**

Do not use more than **30 psi** compressed air for cleaning purposes. Debris trajected under pressure can cause injury to eyes. Use source of compressed air under **30 psi** and eye protection to prevent injury to personnel.

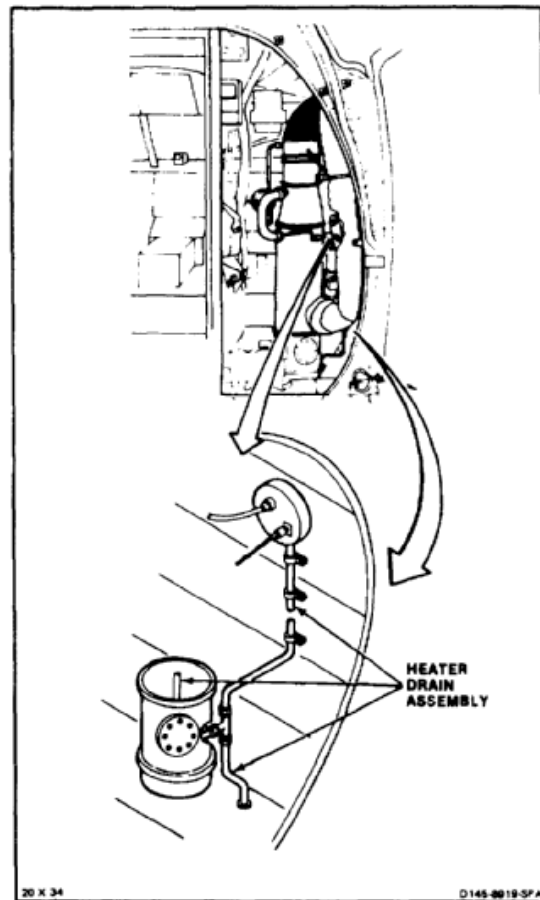



**13-9 CLEAN HEATER DRAIN ASSEMBLY (Continued)**

13-9

1. Remove eight screws (1), washers (2), access cover (3), and gasket (4) from transition duct (5).

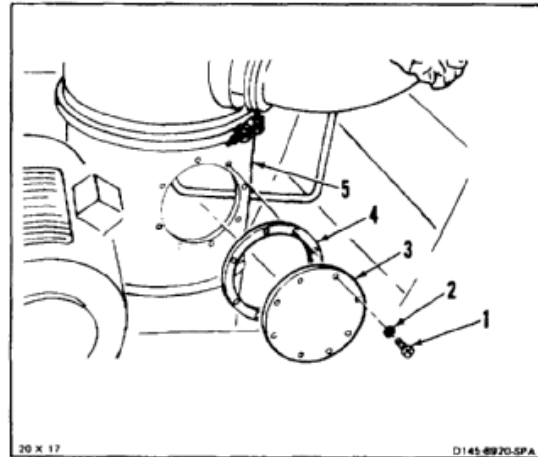

2. Disconnect dRAINTUBE (6) from heater connection (7) and tee (8). Remove tube (6).
3. Disconnect drain tube (9) from tee (8). Remove tube (9).
4. Disconnect drain tube (10) from tee (8) and heater fuel control (11).
5. Remove two screws (12) and clamps (13) from tube (10). Remove tube.

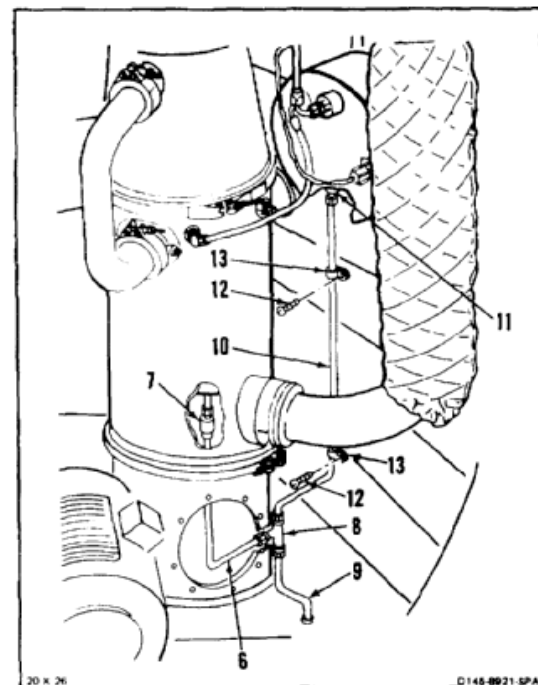

6. Wearing gloves (E186), clean outside of tubes (6, 9, and 10). Use dry cleaning solvent (E161) and brush.
7. Flush inside of tubes (6, 9, and 10). Use dry cleaning solvent (E161) and compressed air. Wear goggles and gloves (E186).
8. Dry tubes (6, 9, and 10). Use compressed air.

**INSPECT**

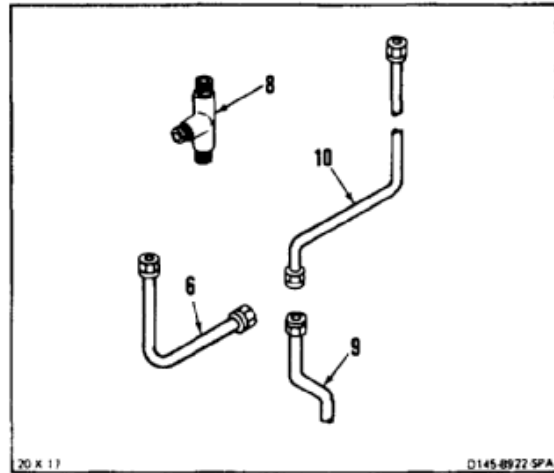

9. Connect drain tube (10) to control (11) and tee (8).
10. Insert tube (9) through grommet (14). Connect tube to tee (8).
11. Connect tube (6) to heater connection (7) and tee (8).
12. Install two clamps (13) and screws (12).

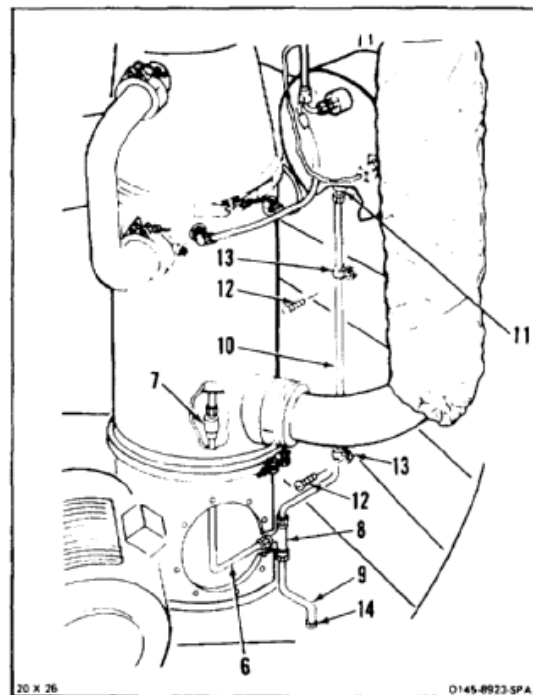

**13-9 CLEAN HEATER DRAIN ASSEMBLY (Continued)****13-9**

13. Install access cover (3), gasket (4), washers (2), and eight screws (1) in transition duct (5).

***FOLLOW-ON MAINTENANCE:***

None

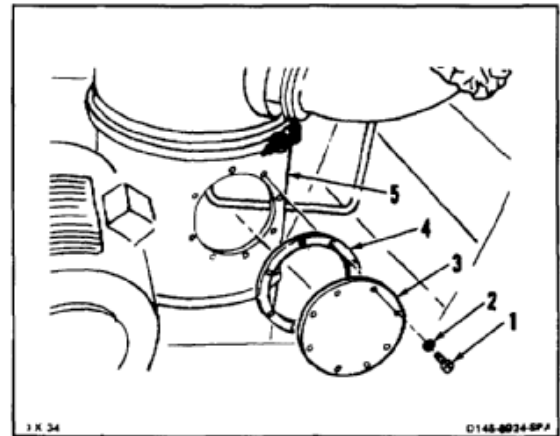

END OF TASK

INITIAL SETUP

**Applicable Configurations:**

All

**Tools:**

Aircraft Mechanic's Tool Kit, NSN 5180-00-323-4692  
 Deep Well Socket, 1 Inch

**Materials:**

None

**Personnel Required:**

Medium Helicopter Repairer

**Equipment Condition:**

Battery Disconnected (Task 1-39)  
 Electrical Power Off  
 Heater Compartment Acoustic Blanket Removed  
 (Task 2-208)

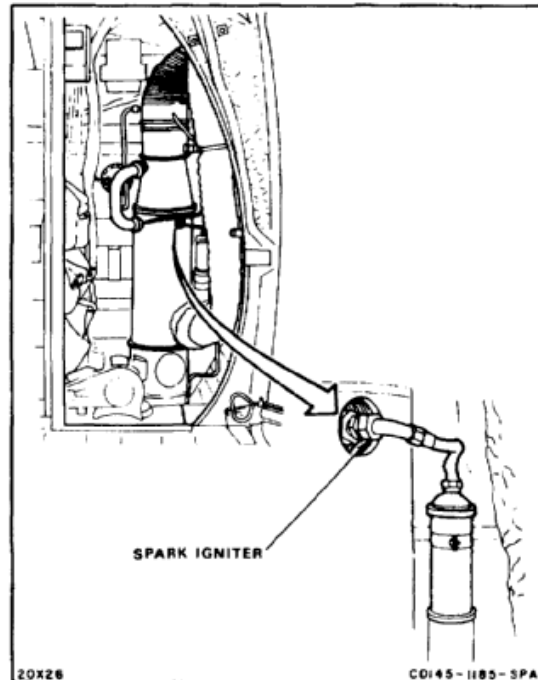

1. Disconnect shielded lead (1) from spark igniter (2).

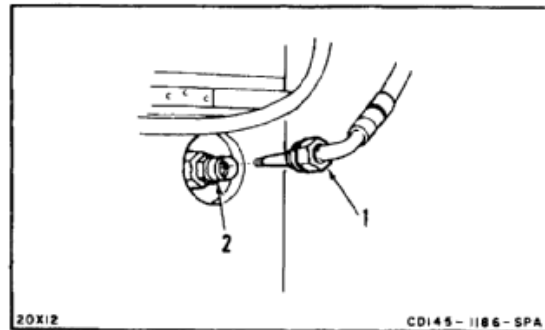

2. Remove igniter (2) and gasket (3) from heater (4).

**FOLLOW-ON MAINTENANCE:**

None

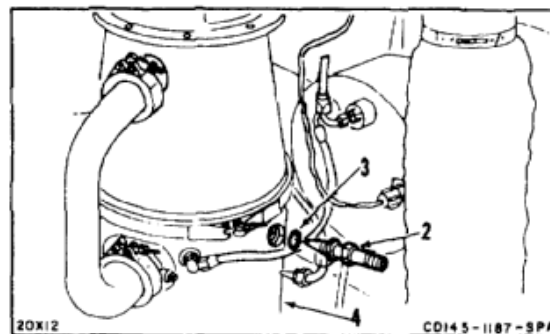

END OF TASK

**13-11 INSTALL HEATER SPARK IGNITER**

13-11

**INITIAL SETUP**

**Applicable Configurations:**

All

**Tools:**

Aircraft Mechanic's Tool Kit, NSN 5180-00-323-4692  
 Torque Wrench, 100 to 750 Inch-Pounds  
 Deep Well Socket, 1 Inch

**Materials:**

None

**Parts:**

Gasket

**Personnel Required:**

Medium Helicopter Repairer  
 Inspector

**References:**

TM 55-1520-240-23P

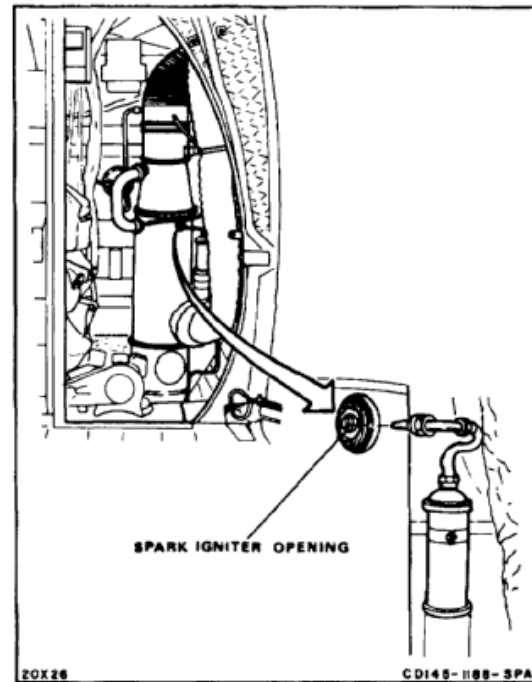

1. Install spark igniter (1) and gasket (2) in heater (3).

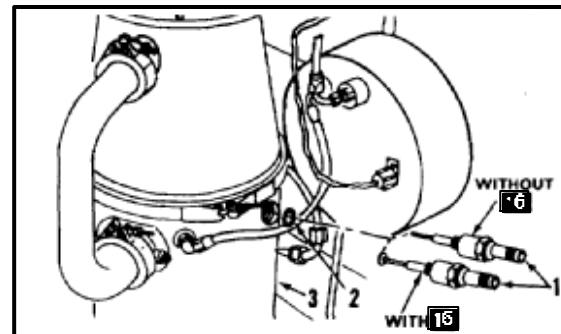

2. Torque igniter (1) to **335 inch-pounds**.
3. Connect shielded lead (4) to plug (1).

**INSPECT**

**FOLLOW-ON MAINTENANCE:**

None

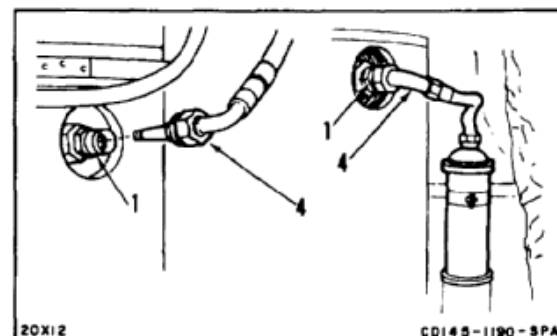

END OF TASK

## INITIAL SETUP

**Applicable Configurations:**

All

**Tools:**

Aircraft Mechanic's Tool Kit, NSN 5180-00-323-4692

**Materials:**Barrier Material (E80)  
Tape (E388)**Personnel Required:**

Medium Helicopter Repairer

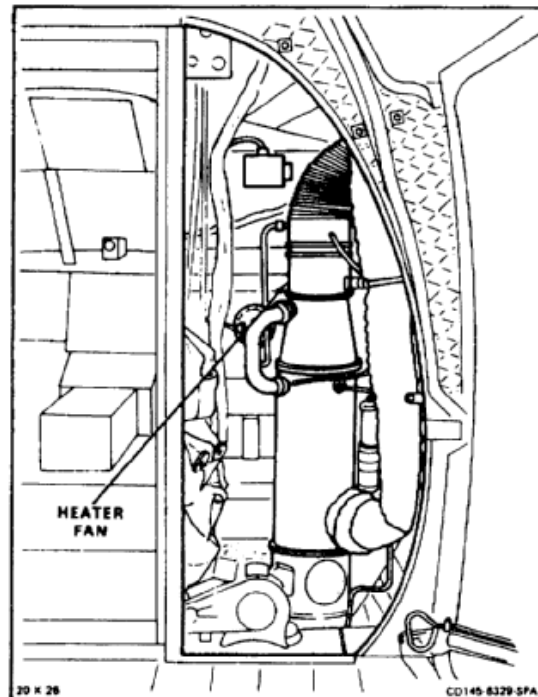
**Equipment Condition:**Battery Disconnected (Task 1-39)  
Electrical Power Off  
Heater Compartment Acoustic Blanket Removed  
(Task 2-208)

1. Remove lockwire and disconnect electrical connector (1).
2. Disconnect tube (2).
3. Loosen lower clamp (3) and disconnect duct (4) from fan (5). Remove clamp.
4. Remove 8 screws (6), 8 nuts (7), 16 washers (8), and 1 clamp (9).
5. Remove fan (5) and gasket (10) from adapter (11).
6. Cover top of adapter (11). Use barrier material (E80) and tape (E388).

**FOLLOW-ON MAINTENANCE:**

None

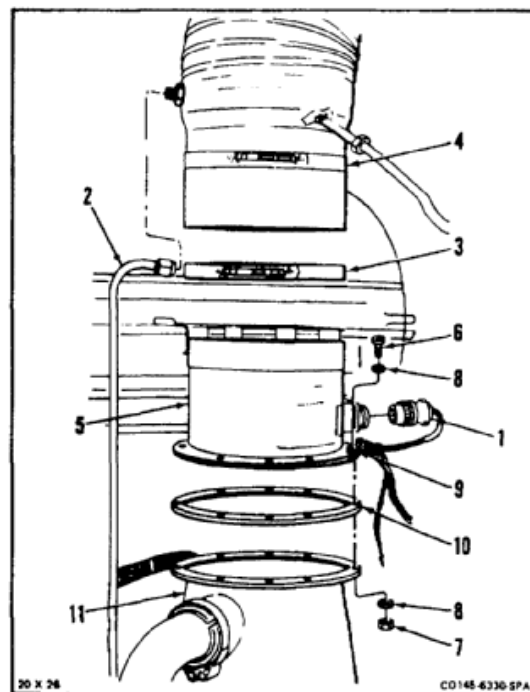

END OF TASK

## INITIAL SETUP

**Applicable Configurations:**

All

**Tools:**

Electrical Repairer's Tool Kit, NSN 5180-00-323-4915  
 Technical Inspection Tool Kit, NSN 5180-00-323-5114  
 Wood Dowel, 3/8 Inch X 8 Inch  
 Socket Wrench Handle  
 Retaining Ring Pliers  
 Telescoping Gage  
 Socket, 3/4 Inch  
 Soldering Iron  
 Arbor Press  
 Vise

**Materials:**

Gloves (E184.1)  
 Paper Tags (E264)  
 Emery Cloth (E123)  
 Poly Paint (E285.2)  
 Epoxy Primer (E292.1)

**Personnel Required:**

Aircraft Electrician  
 Machinist  
 Inspector

**References:**

Task 2-350.1  
 TM 55-1500-322-24

**Equipment Condition:**

Off Helicopter Task

**General Safety Instructions:****WARNING**

Epoxy primer (E292.1) and poly paint (E285.2) are flammable and toxic. They can irritate skin and cause burns. Use only with adequate ventilation, away from heat, sparks, and open flame. Avoid contact with skin, eyes, or clothing. In case of contact, immediately flush skin or eyes with water for at least **15 minutes**. Get medical attention for eyes.

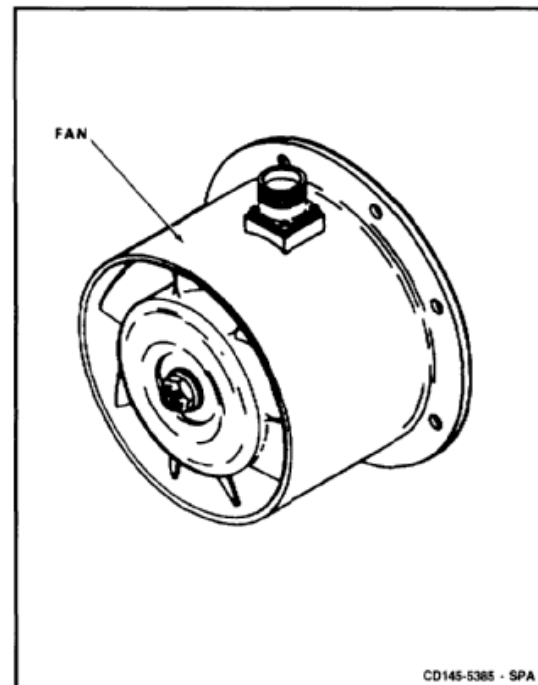

**DISASSEMBLE FAN**

1. Clamp fan (1) in vise (2).

**NOTE**

Wood dowel prevents rotor from turning when removing nut.

2. Insert wood dowel (3) through vanes (4).
3. Remove nut (5), washer (6), and spun nose (7).
- 3.1. Inspect spun nose (7). There shall be no dents, cracks, or nicks.
4. Remove dowel (3).
5. Remove fan (1) from vise.

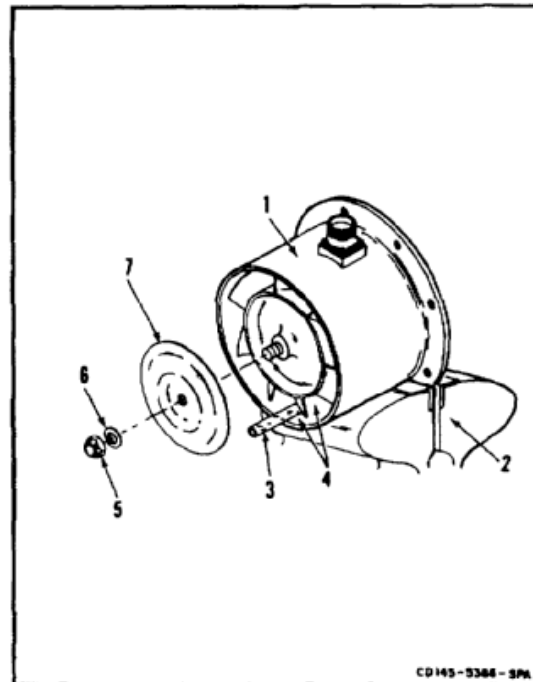



6. Remove rotor (8). If rotor is tight, lift fan (1) by rotor and tap shaft (9). Use plastic-face hammer.

**NOTE**

Spun nose and rotor are a matched set. If one is damaged, both must be replaced.

- 6.1. Inspect rotor (8). There shall be no cracks or nicks.
- 6.2. Measure bore (9.1) in rotor (8). Diameter shall not be more than **0.501 inch**.
- 6.3. Measure width of keyway (9.2). Width shall not be more than **0.128 inch**.

**NOTE**

Rotor is magnesium.

- 6.4. Inspect rotor (8) for eroded finish. Touch up as needed. Use epoxy primer (E292.1) and poly paint (E285.2) (Task 2-350.1). Wear gloves (E184.1).
7. Remove key (10).
8. Remove lockwire, four screws (11), and washer (12). Pull receptacle (13) and block (14) away from housing (15) far enough to access wires.
9. Remove tubing (17). Tag and unsolder four wires (16). Use tags (E264).

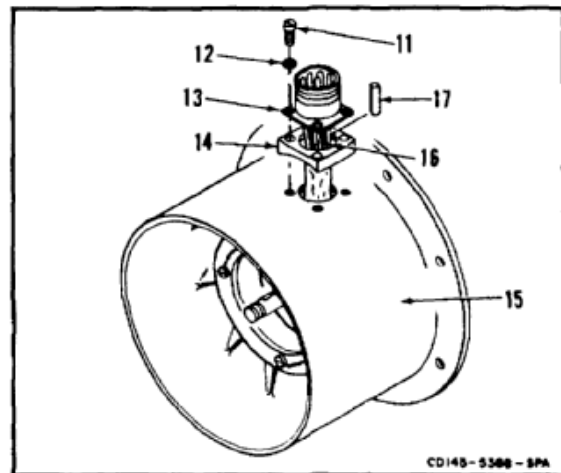
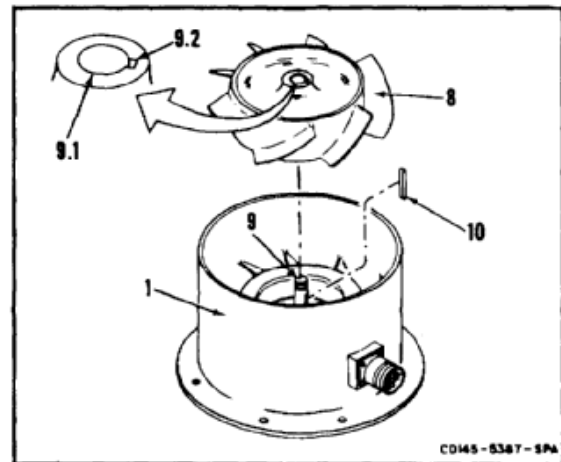

10. Remove lockwire, four screws (18), and four washers (19).
11. Remove motor (20) from housing (15).
- 11.1. Inspect housing (15). There shall be no cracks. There shall be no nicks or scratches deeper than **0.025 inch**.
- 11.2. Blend out scratches in housing (15) less than **0.025 inch** deep. Use emery cloth (E123).

**NOTE**

Housing is magnesium.

- 11.3. Inspect housing (15) for corrosion. Clean and treat corrosion (Task 2-347).
- 11.4. Touch up housing (15) as needed. Use epoxy primer (E292.1) and poly paint (E285.2) (Task 2-350.1). Wear gloves (E184.1).

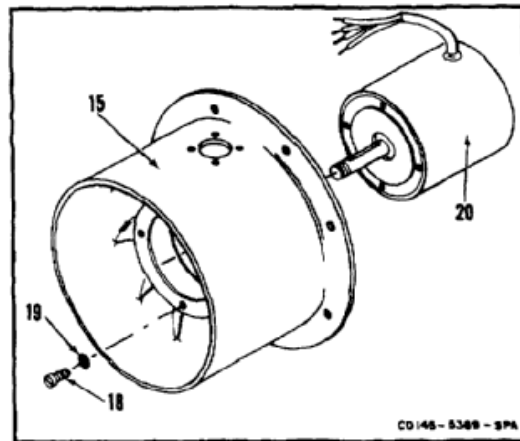
**DISASSEMBLE MOTOR**

12. Remove retaining ring (21). Remove rotor (22) from stator (23).
13. Remove endbell (24) and loading washer (25) from rotor (22).
- 13.1. Inspect loading washer (25). Washer shall not be cracked or crushed flat.
14. Remove retaining ring (26) from stator (23).
15. Remove bearing (27) from rotor (22) and bearing (27) from stator (23). Inspect bearings (TM 55-1500-322-24).
16. Inspect rotor (22). There shall be no sign of rubbing against inside of stator (23). There shall be no spalling of bearing surfaces of shaft (28).

**FOLLOW-ON MAINTENANCE:**

None

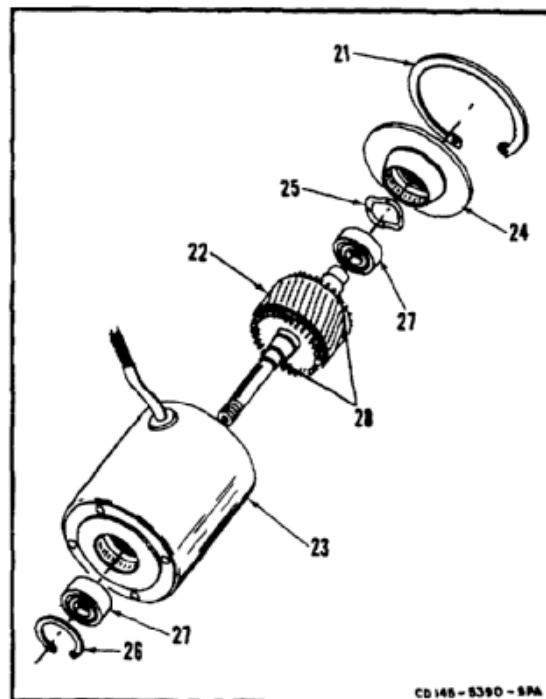

END OF TASK

## INITIAL SETUP

**Applicable Configurations:**

All

**Tools:**

Source of Low Pressure Compressed Air  
Soft Bristle Brush  
Ventilated Oven  
Pneumatic Cleaning Gun  
Container, Two Quart  
Goggles

**Materials:**

Cloths (E120)  
Dry Cleaning Solvent (E161)  
Gloves (E186)

**Personnel Required:**

Aircraft Electrician

**Equipment Condition:**

Off Helicopter Task  
Heater Fan Disassembled (Task 13-13)

1. Remove loose dirt from all parts (1 thru 13). Use compressed air and brush.

**WARNING**

Dry cleaning solvent (E161) is flammable and toxic. It can irritate skin and cause burns. Use only in well-ventilated area, away from heat and open flame. In case of contact, immediately flush skin or eyes with water for at least **15 minutes**. Get medical attention for eyes.

**CAUTION**

Spray parts; do not soak parts in solvent. Excess solvent will damage plastic, insulation, or rubber.

2. Spray parts (1, 3 thru 13) with solvent (E161). Try to keep solvent away from rubber and insulation on wires (2). Wear goggles and gloves (E186).
3. Dry parts (1 thru 13) with compressed air and cloths (E120).
4. Bake stator (3) and rotor (4) in oven at **275°F (135°C)** for **2 hours**. Remove stator. Wear gloves (E186).

**FOLLOW-ON MAINTENANCE:**

None

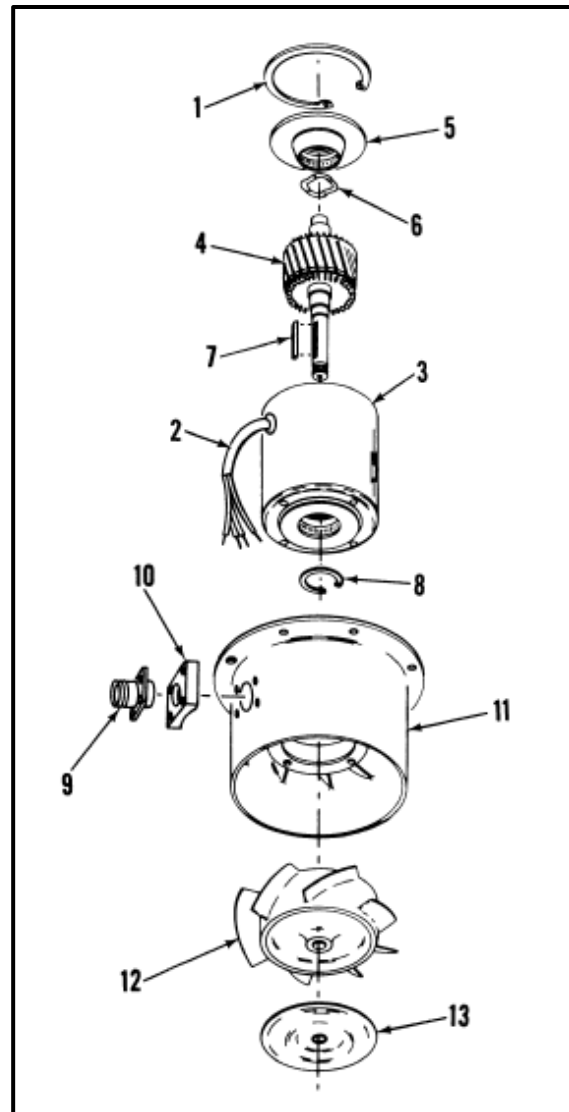

END OF TASK

INITIAL SETUP

**Applicable Configurations:**

All

**Tools:**

- Electrical Repairer's Tool Kit, NSN 5180-00-323-4915
- Arbor Press
- Gun Heater
- Retaining Ring Pliers
- Socket Wrench Handle
- Socket, 3/4 Inch
- Vise
- Soldering Iron
- Wood Dowel, 3/8 Inch X 8 Inch

**Materials:**

- Lockwire (E230)
- Solder (E360)
- Heat Shrinkable Tubing (E431)

**Personnel Required:**

- Aircraft Electrician
- Machinist
- Inspector

**References:**

- TM 55-1520-240-23P
- TM 55-1500-322-24
- TM 55-1500-323-25

**Equipment Condition:**

Heater Fan 500702-5310 Parts Cleaned (Task 13-14)

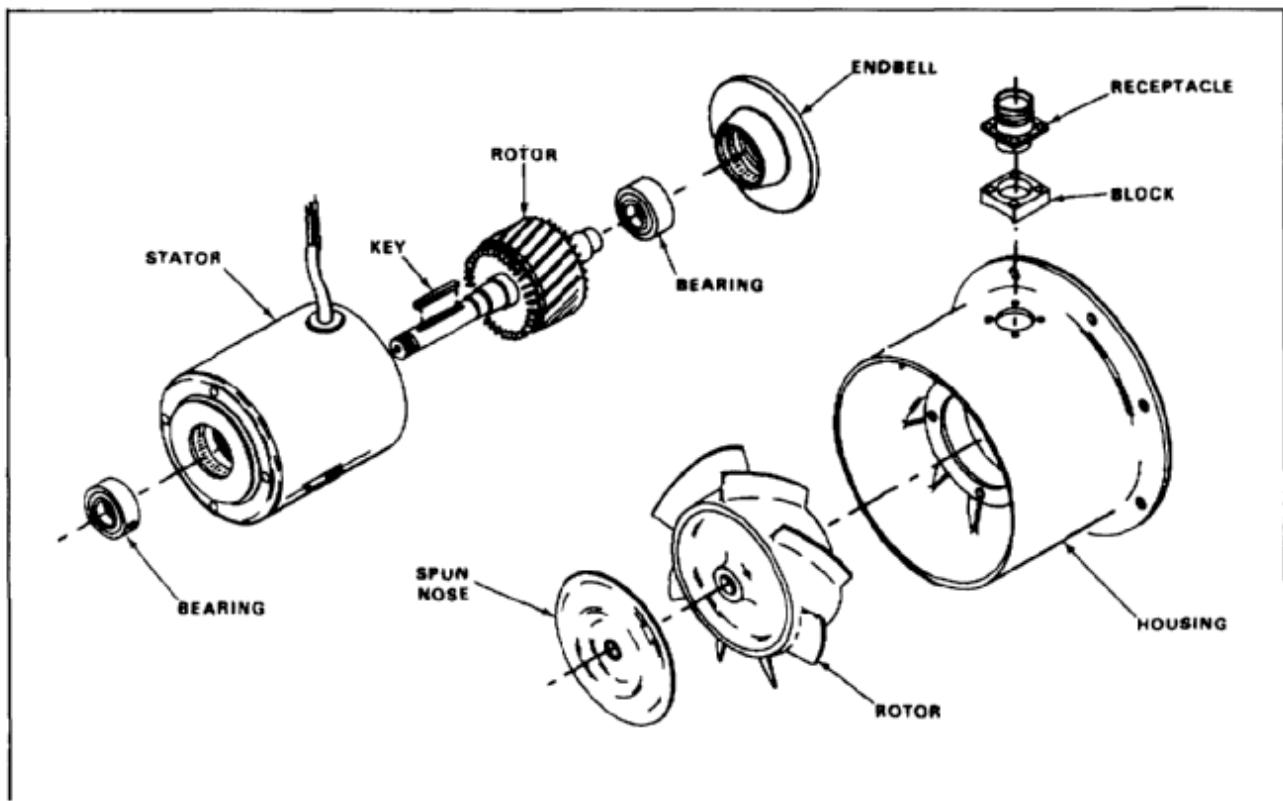

**ASSEMBLE MOTOR**

1. Install bearing (1) in stator (2) and bearing (3) on rotor (4) (TM 55-1500-322-24).
2. Slide rotor (4) into stator (2). Make sure shaft (5) bottoms on bearing (1).
3. Install loading washer (6) and endbell (7) in stator (2). Install retaining ring (8), flat side down.
4. Install retaining ring (9), flat side down.

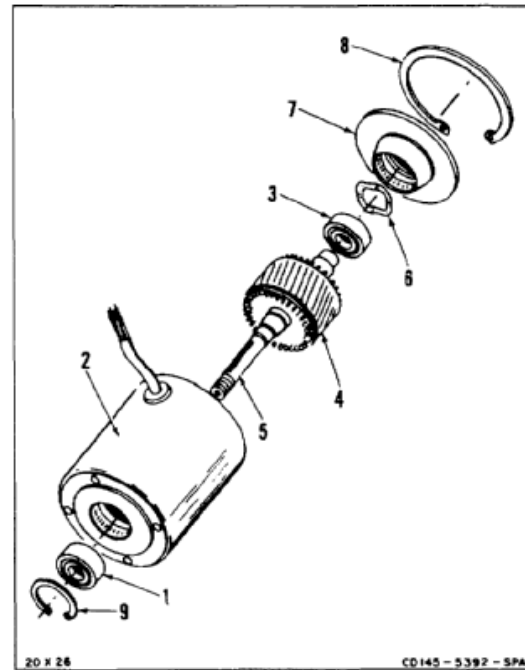
**INSPECT****ASSEMBLE FAN**

5. Install motor (10) in housing (11). Align wires (12) with hole (13). Align four screw holes (14) with four holes (15) in housing.
6. Install four screws (16) and washers (17).
7. Lockwire screws (16). Use lockwire (E230).

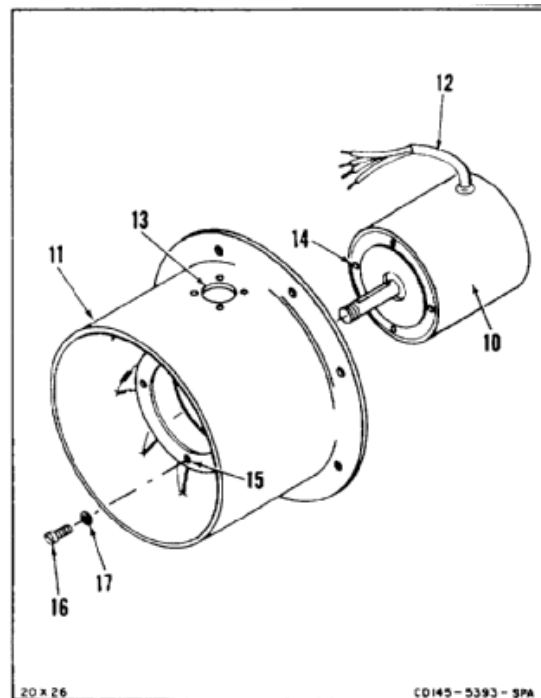
**INSPECT**

8. Route four wires (12) through hole (13) and block (18).
9. Slide piece of tubing (E431) (19) onto each of four wires (12).
10. Solder four wires (12) to receptacle (20). Use solder (E360). Shrink tubing (19) over solder (TM 55-1500-323-25). Remove tags.
11. Position block (18) and receptacle (20) on housing (11). Install four screws (21) and washers (22).
12. Lockwire screws (21). Use lockwire (E230).

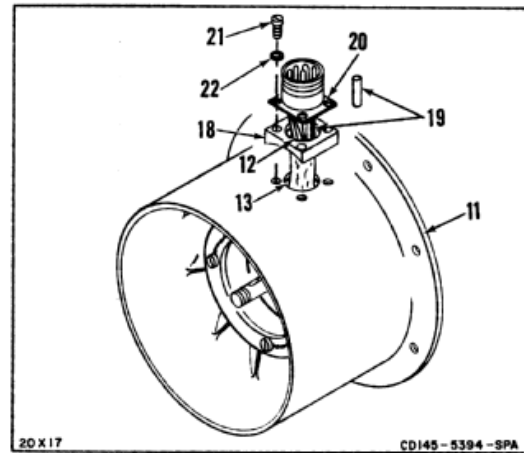

13. Install key (23) in shaft (5).
14. Slide rotor (24) onto shaft (5). Make sure groove (25) is up and keyway (26) aligns with key (23).

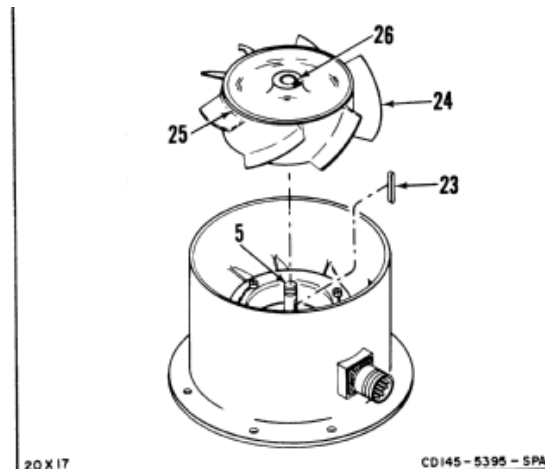

15. Clamp fan (27) in vise (28).

**NOTE**

Wood dowel prevents rotor from turning when installing nut.

16. Insert wood dowel (29) through vanes (30).
17. Align match marks on spun nose (31) and rotor (24). Install spun nose, washer (32), and nut (33) on shaft (5).
18. Remove dowel (29).
19. Remove fan (27) from vise (28).

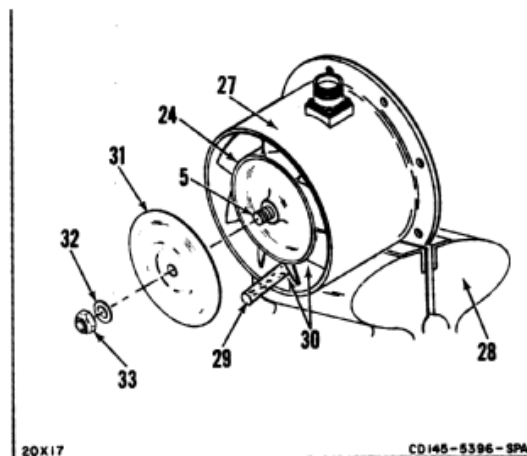

20. Spin rotor (24). Rotor shall spin freely.

***FOLLOW-ON MAINTENANCE:***

Test heater fan (Task 13-16).

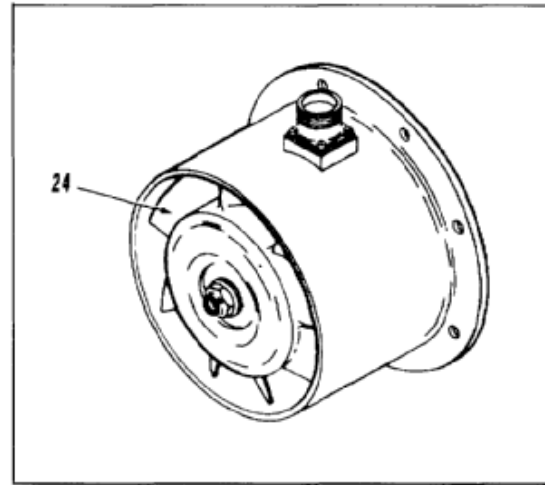

END OF TASK

INITIAL SETUP

**Applicable Configurations:**

All

**Tools:**

- Electrical Repairer's Tool Kit, NSN 5180-00-323-4915
- Ammeters (3), 0 to 20 Amperes
- Power Supply, 3-Phase 115/200 Vac 400-Hz, 15 Ampere Capacity
- Plug (MS3456W18-11S)
- Stroboscope
- Support Plate (APP E-20)
- Vise

**Materials:**

None

**Parts:**

- Bolts
- Nuts
- Washers

**Personnel Required:**

- Aircraft Electrician
- Inspector

**References:**

Appendix E

**Equipment Condition:**

- Off Helicopter Task
- Test Setup

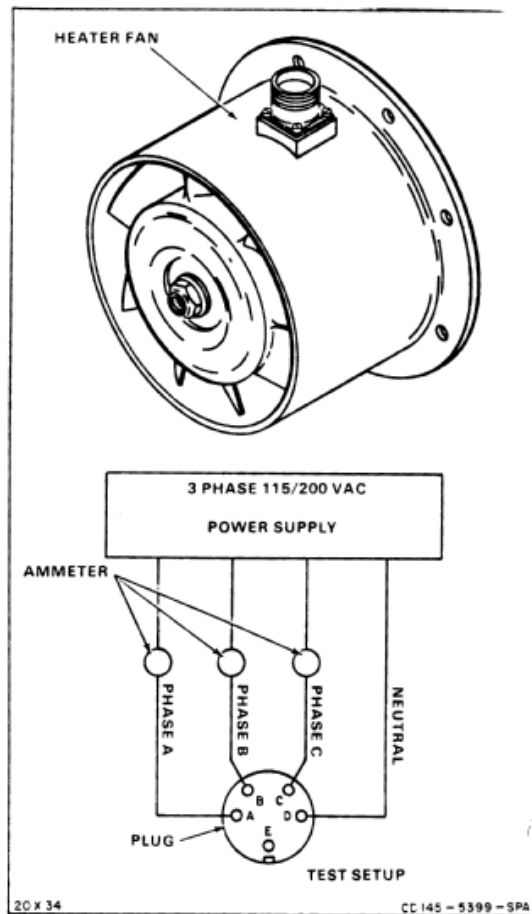

1. Clamp support plate (1) in vise (2).
2. Position fan (3) on plate (1). Install two bolts (4), washers (5), and nuts (6) in plate and fan.

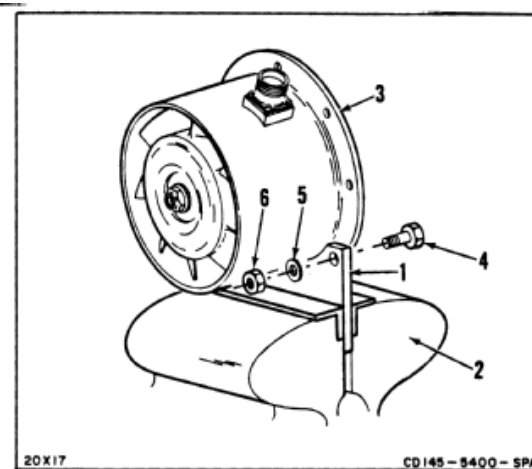



3. Connect test setup to connector (7) of fan (3).
4. Turn on power supply (8). Current shall be **8.1 to 8.9 amperes** on each ammeter (9).

**NOTE**

Rotation direction of rotor is marked on fan housing.

5. Check that rotor (10) is turning in direction marked on housing of fan (3).
6. Measure rotational velocity of rotor (10). Velocity shall be **11,400 to 11,800 rpm**. Use stroboscope.
7. Shut down power supply (8). Disconnect test setup from connector (7).

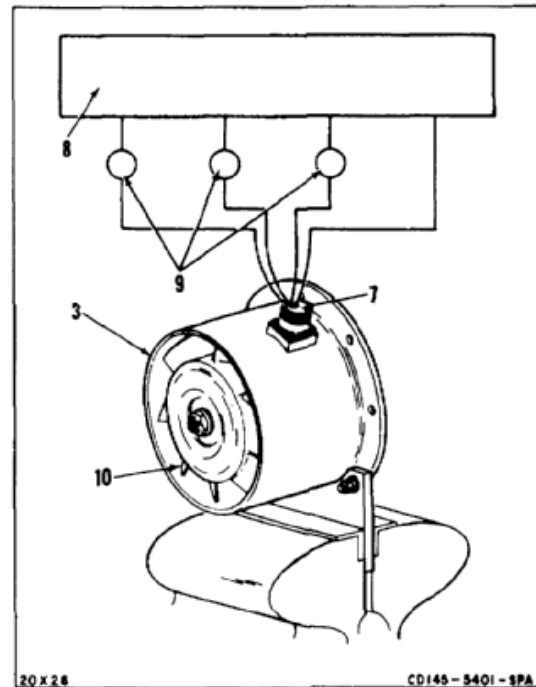

8. Remove two nuts (6), washers (5), and bolts (4) from plate (1) and fan (3). Remove fan.
9. Remove plate (1) from vise (2).

**FOLLOW-ON MAINTENANCE:**

None

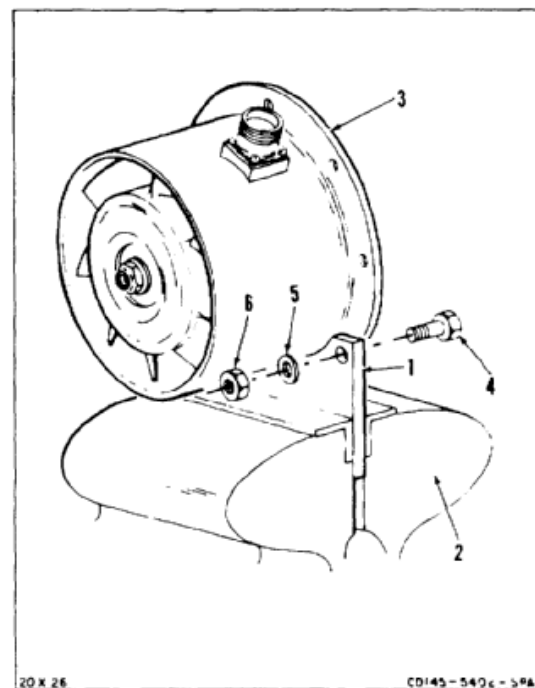

END OF TASK

INITIAL SETUP

**Applicable Configurations:**

All

**Tools:**

Aircraft Mechanic's Tool Kit, NSN 5180-00-323-4692

**Materials:**

Lockwire (E231)

**Parts:**

Gasket

**Personnel Required:**

Medium Helicopter Repairer  
Inspector

**References:**

TM 55-1520-240-23P

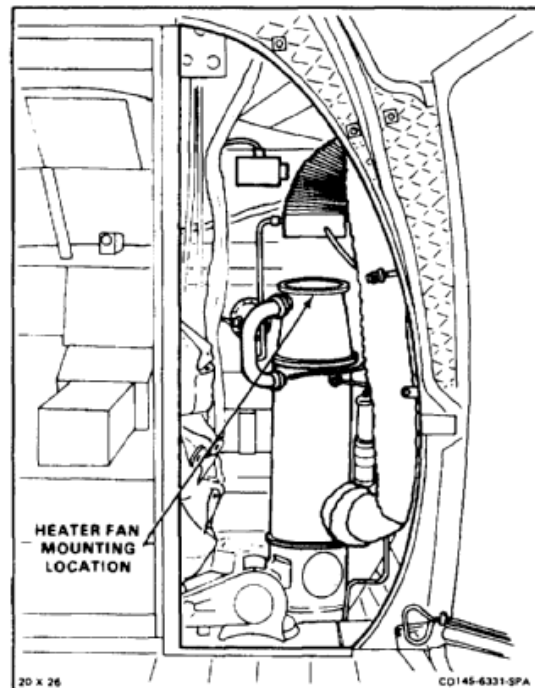

1. Remove barrier material and tape from adapter (1).
2. Position fan (2) and gasket (3) on adapter (1) with receptacle (4) **90°** from combustion tube (5).
3. Align holes in fan (2), adapter (1), and gasket (3). Install 8 screws (6), 8 nuts (7), 16 washers (8), and 1 clamp (9).

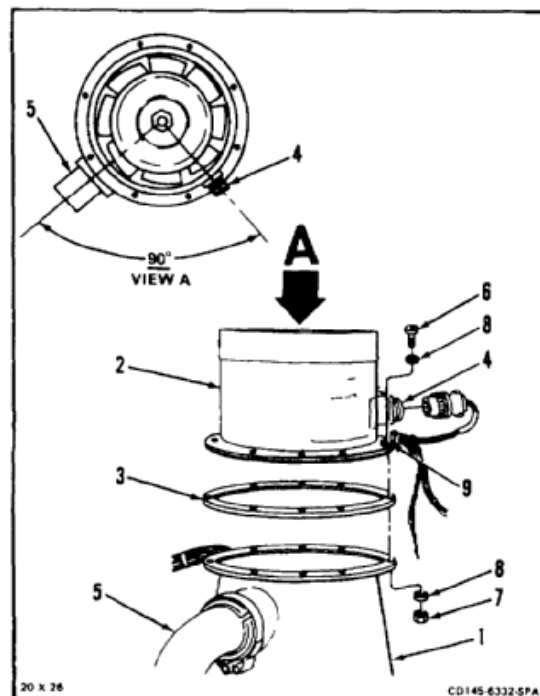

**13-17 INSTALL HEATER FAN (Continued)**

13-17

4. Slide clamp (10) onto duct (11) and connect duct to top of fan (2). Tighten clamp around duct, fan, and bracket (12).
5. Connect tube (13) to nipple (14).
6. Connect electrical connector (15) and lockwire it. Use lockwire (E231).

**INSPECT****FOLLOW-ON MAINTENANCE:**

Perform operational check (TM 55-1520-240-T).  
Install heater compartment acoustic blanket (Task 2-210).

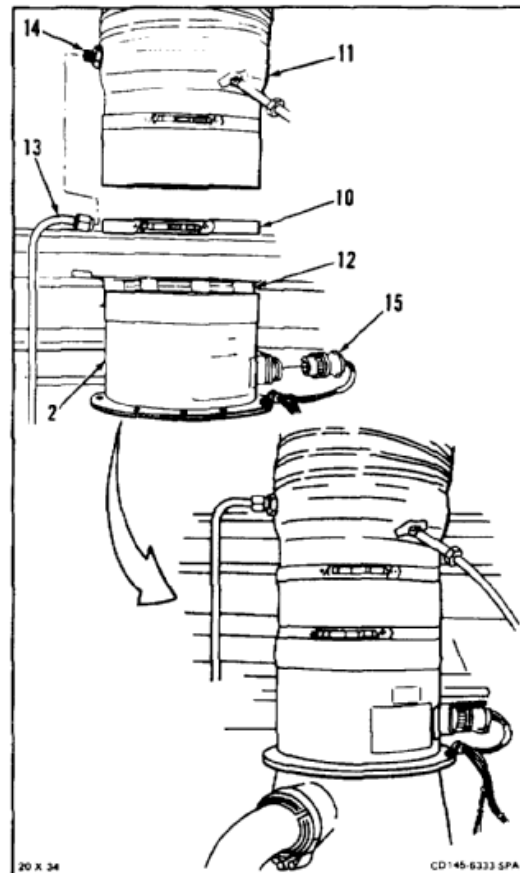

END OF TASK

INITIAL SETUP

**Applicable Configurations:**

All

**Tools:**

Aircraft Mechanic's Tool Kit, NSN 5180-00-323-4692  
Workstand

**Materials:**

Barrier Material (E80)  
Tape (E388)

**Personnel Required:**

Medium Helicopter Repairer (2)

**Equipment Condition:**

Battery Disconnected (Task 1-39)  
Electrical Power Off  
Heater Compartment Acoustic Blanket Removed  
(Task 2-208)

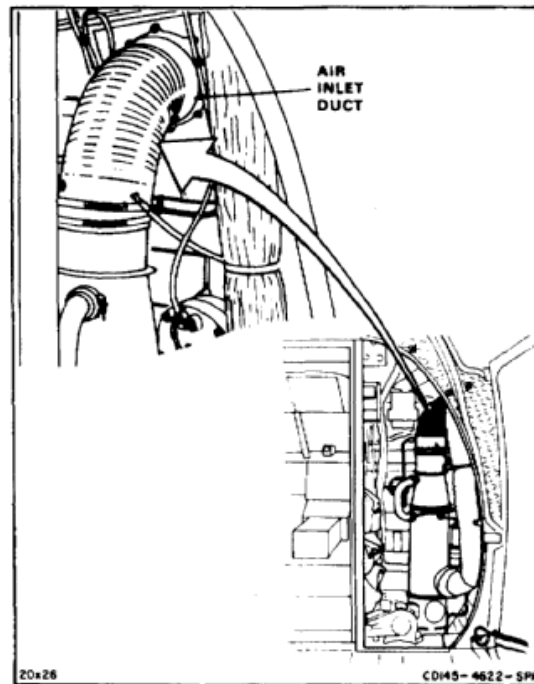

1. Loosen clamp (1). Disconnect rubber tube (2) and remove clamp.
2. Disconnect metal tube (3).
3. Loosen two clamps (4). Remove hose (5) and two clamps.

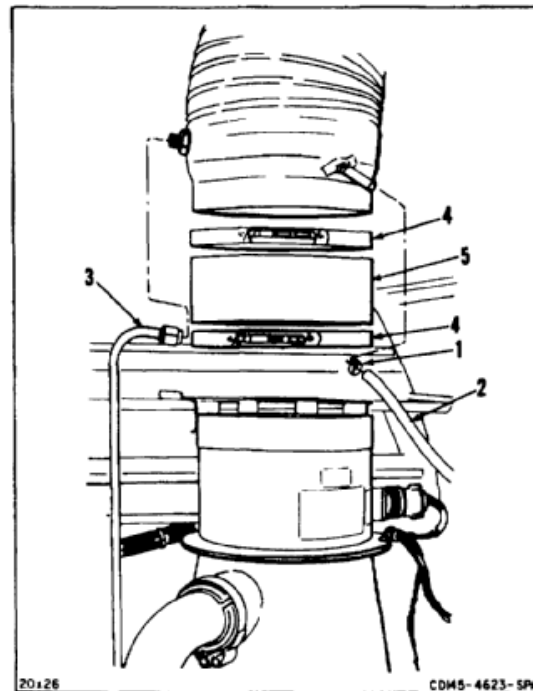

**13-18 REMOVE AIR INLET DUCT (Continued)****13-18**

4. Remove eight nuts (7) and washers (8).
5. Remove air inlet duct (9) and wire fabric (10).
6. Remove seal (11) if worn, deformed, or otherwise damaged.
7. From outside helicopter have helper remove four screws (12) and four snap fasteners (13).
8. Cover opening in top of fan (14). Use barrier material (E80) and tape (E388).

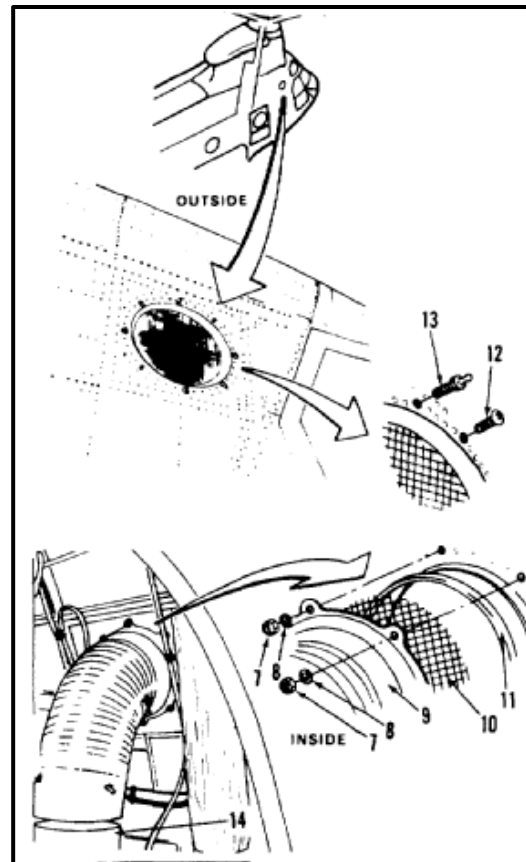
**FOLLOW-ON MAINTENANCE:**

None

END OF TASK

## INITIAL SETUP

**Applicable Configurations:**

All

**Tools:**

Aircraft Mechanic's Tool Kit, NSN 5180-00-323-4692  
 Stiff-Bristled Brush  
 Workstand

**Materials:**

Cement (E103)  
 Cloths (E120)  
 Sealant (E336)  
 Solvent (E161)  
 Gloves (E186)

**Personnel Required:**

Medium Helicopter Repairer (2)  
 Inspector

**References:**

TM 55-1520-240-23P

**General Safety Instructions:****WARNING**

Solvent (E161) is flammable and toxic. It can irritate skin and cause burns. Use only in well-ventilated area away from heat and open flame. In case of contact, immediately flush skin or eyes with water for at least **15 minutes**. Get medical attention for eyes.

**WARNING**

Sealant (E336) can irritate skin and cause burns. Avoid contact with skin, eyes, and clothing. In case of contact, immediately flush skin or eyes with water for at least **15 minutes**. Get medical attention for eyes.

**WARNING**

Cement (E103) is flammable and toxic. It can irritate skin and cause burns. Use only with adequate ventilation, away from heat or open flame. Avoid contact with skin, eyes, or clothing. In case of contact, immediately flush skin or eyes with water for at least **15 minutes**. Get medical attention for eyes.

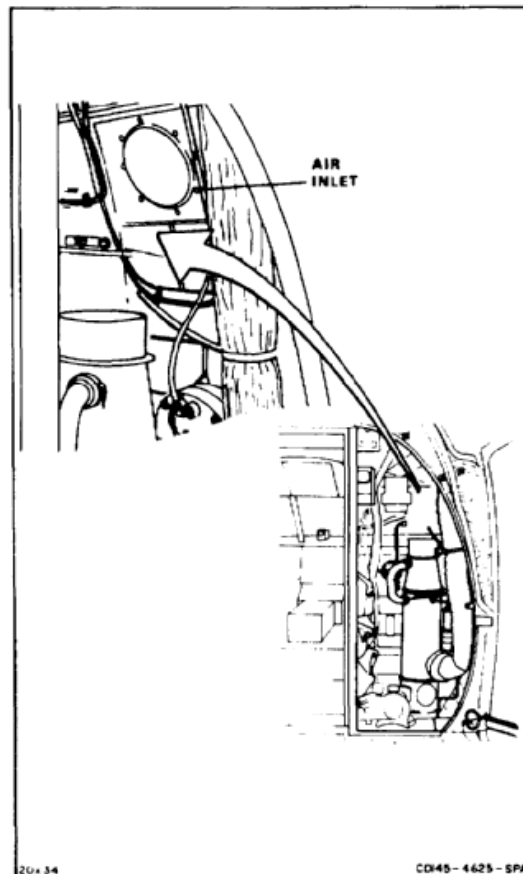

**13-19 INSTALL AIR INLET DUCT (Continued)****13-19**

1. Remove old sealant from around inlet (1). If seal (2) was removed, remove old adhesive from flange (3). Use solvent (E161) and cloths (E120). Wear gloves (E186).
2. If seal (2) was removed, install new seal on flange (3). Use cement (E103).

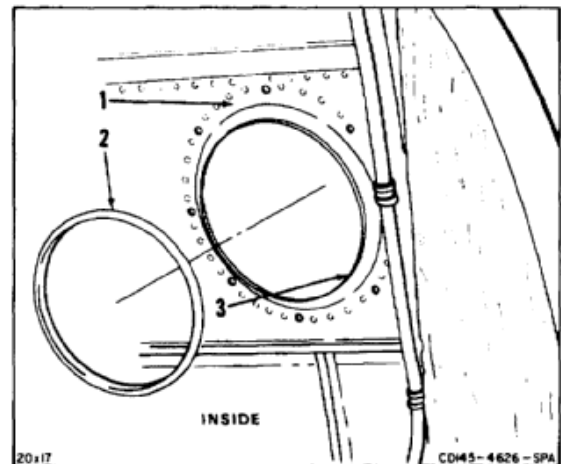

3. Have helper remove old sealant from around inlet (1) outside helicopter. Use solvent (E161) and cloths (E120). Wear gloves (E186).
4. Clean wire fabric (4). Use solvent (E161) and stiff-bristled brush. Wear gloves (E186).
5. Remove tape and barrier material from fan (5).
6. From outside helicopter, have helper install four screws (6) and four snap fasteners (7).
7. Position wire fabric (4) and air inlet duct (8) over inlet (1).
8. From inside, install eight nuts (9) and washers (10) while helper holds screws (6) and snap fasteners (7) outside.

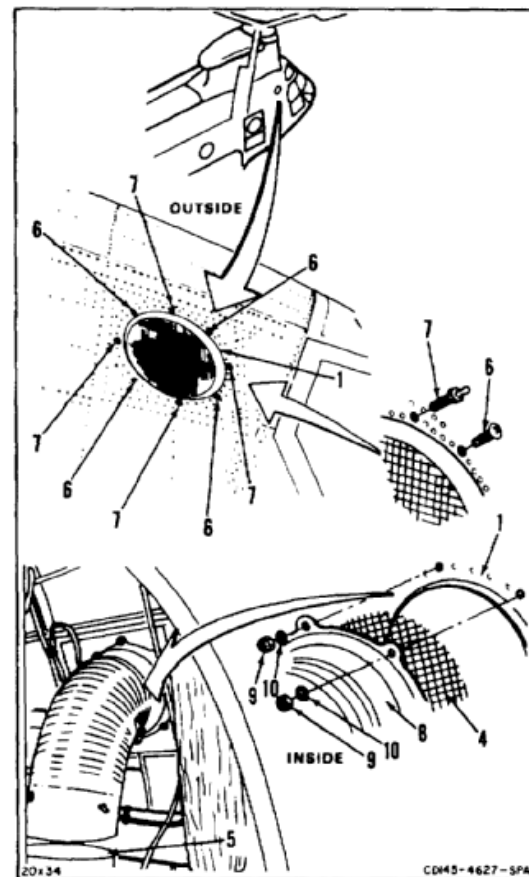

9. Slide hose (11) up over duct (8) and slide two clamps (12 and 13) over hose.
10. Connect hose (11) to fan (5). Tighten clamp (12) around hose and duct (8). Tighten clamp (13) around hose, fan, and bracket (14).
11. Slide clamp (15), over rubber tube (16), connect tube to duct (8), and tighten clamp.
12. Connect metal tube (17) to duct (8).
13. Apply bead of sealant (E336) around top of duct (8). Wear gloves (E186).

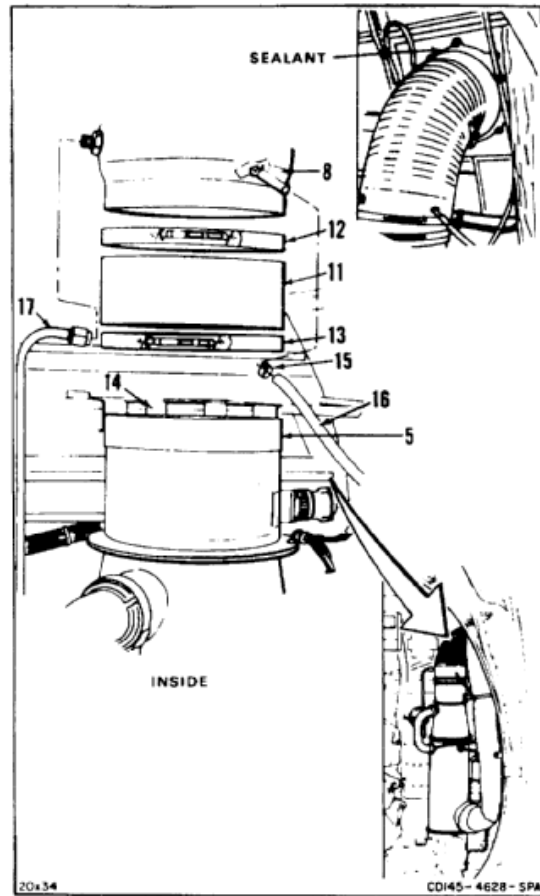

14. Have helper apply sealant (E336) over screws (6) and around fasteners (7) outside helicopter. Wear gloves (E186).

**INSPECT**

**FOLLOW-ON MAINTENANCE:**

Install heater compartment acoustic blanket (Task 2-210).

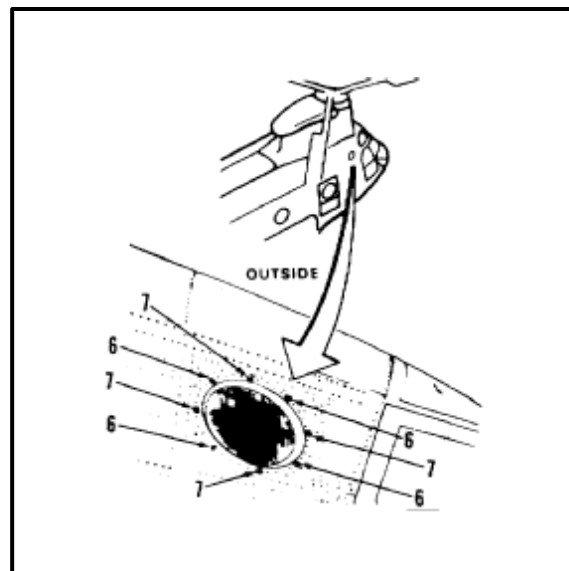

END OF TASK



**13-20 REMOVE HEATER EXHAUST PIPE****13-20****INITIAL SETUP****Applicable Configurations:**

All

**Tools:**

Aircraft Mechanic's Tool Kit, NSN 51 80-00-323-4692

**Materials:**

None

**Personnel Required:**

Medium Helicopter Repairer

**Equipment Condition:**

Battery Disconnected (Task 1-39)  
 Electrical Power Off  
 Hydraulic Power Off  
 Heater Compartment Acoustical Blanket Removed  
 (Task 2-208)

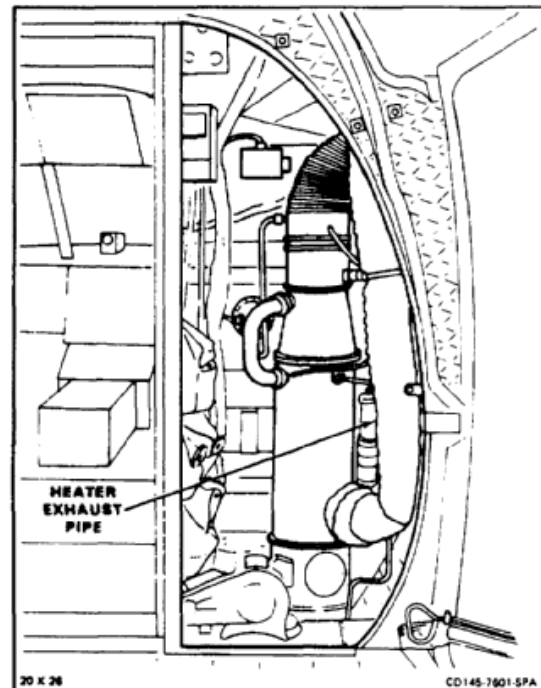

1. Remove lacewire (1) from exhaust shroud elbow (2).
2. Remove clamp (3).

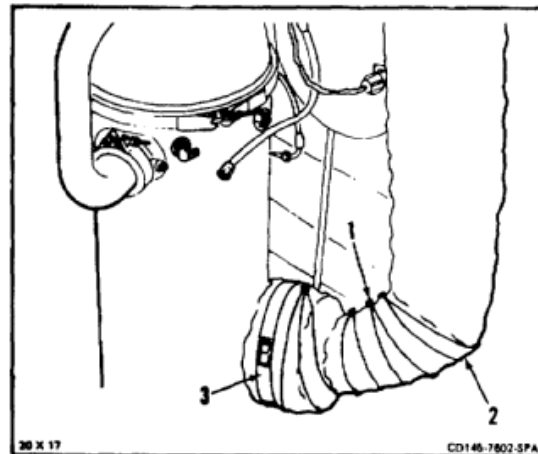

3. Remove exhaust shroud elbows (2) from exhaust pipe (4).
4. Remove lockwire and remove clamp (5) from pipe (4).

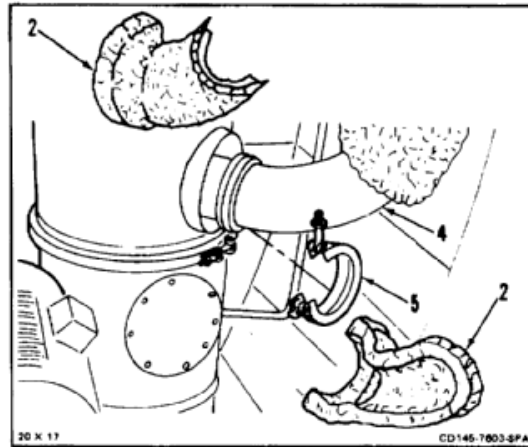

5. Remove clamps (6 and 7) from stack (8).
6. Support pipe (3). Remove clamp (9) and pipe.
7. Remove gasket (10) if worn or damaged.

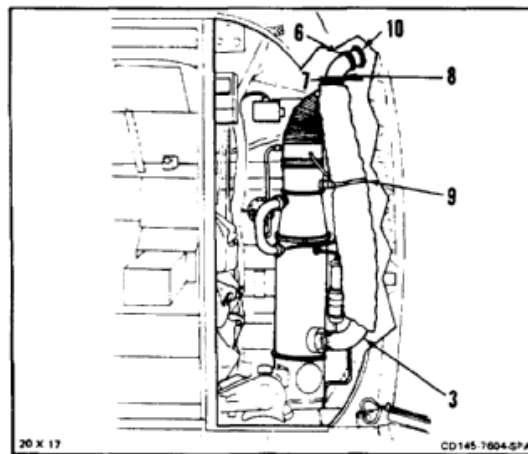

8. Remove stack (8) from pipe (3).
9. Remove wire (1) from exhaust shroud (11). Remove shroud from pipe (3).

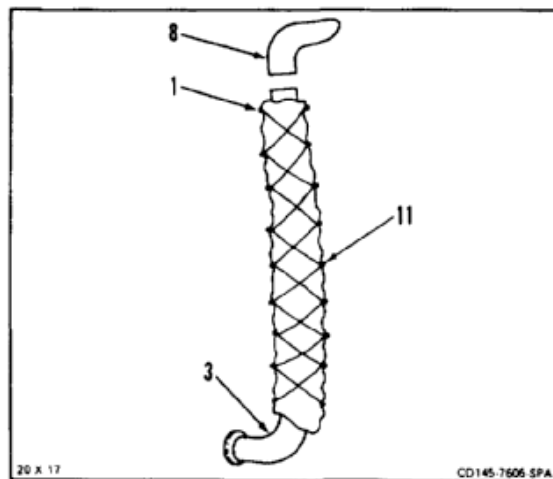

**FOLLOW-ON MAINTENANCE:**

None

END OF TASK

**13-21 INSTALL HEATER EXHAUST PIPE****13-21****INITIAL SETUP****Applicable Configurations:**

All

**Tools:**

Aircraft Mechanic's Tool Kit, NSN 51 80-00-323-4692

**Materials:**

Gloves (E186)  
 Lockwire (E231)  
 Lockwire (E233)  
 Sealant (E332.1)  
 Dry Cleaning Solvent (E162)  
 Cloth (E120)

**Personnel Required:**

Medium Helicopter Repairer  
 Inspector

**References:**

TM 55-1520-240-23P  
 TM 1-1500-204-23  
 Task 2-324

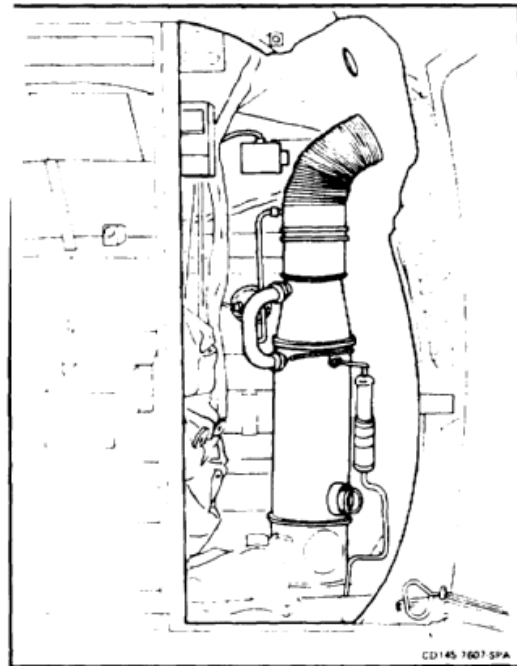

1. Install stack (1) over heater exhaust pipe (2).
2. Position exhaust shroud (3) on pipe (2). Lace wire shroud together. Use lockwire (E233).

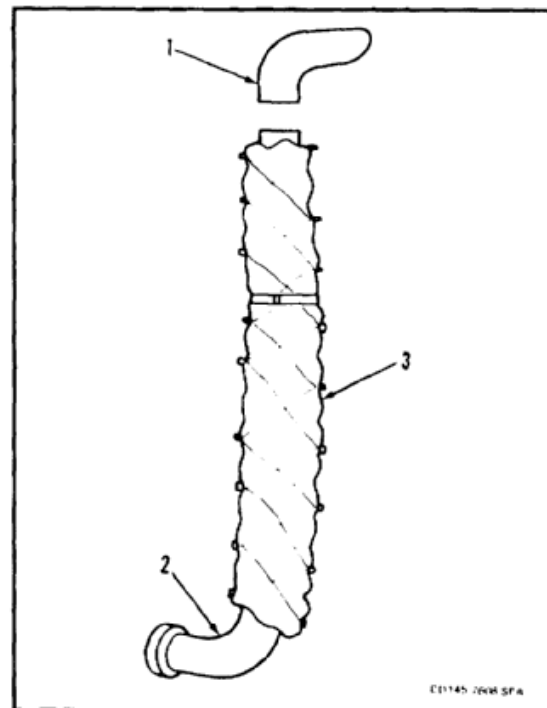

3. If gasket (4) was removed, install new gasket.
4. Insert stack (1) into support (5).
5. Position lower end of pipe (2) on heater outlet (6). Install clamp (7) and lockwire (E231).
6. Install clamp (8) on bracket (9) and shroud (3).

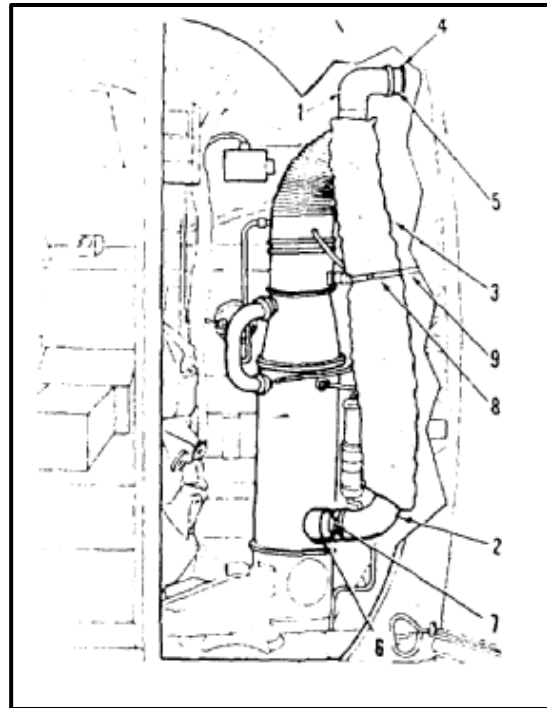

7. Slide stack (1) through support (5) until stack protrudes **0.25 to 0.50 inch** from fuselage (10). Install clamp (11) on support and stack.
8. Install clamp (12) on bracket (13) and stack (1).

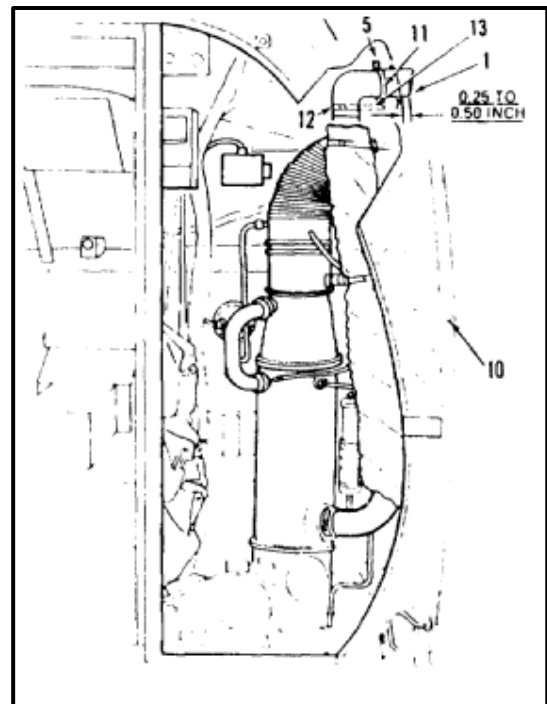

**WARNING**

Dry cleaning solvent (E162) is flammable and toxic. It can irritate skin and cause burns. Use only in well-ventilated area, away from heat and open flame. In case of contact, immediately flush skin or eyes with water for at least **15 minutes**. Get medical attention for eyes.

9. Clean joint between stack (1) and pipe (2). Use dry cleaning solvent (E162) and cloths (E120). Wear gloves.
10. Apply a fillet (14) of sealant (E332.1) to the joint.
11. Install exhaust shroud elbows (15) around pipe (2).
12. Lace wire shroud elbows (15) together. Use lockwire (E233).
13. Install clamp (16).
14. Seal stack (1) to edge of skin. (Task 2-324).

**INSPECT****FOLLOW-ON MAINTENANCE:**

Install heater compartment acoustical blanket (Task 2-210).

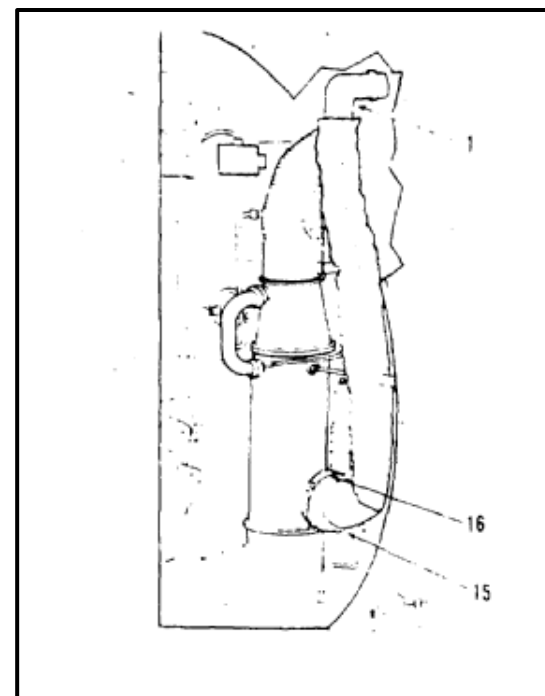
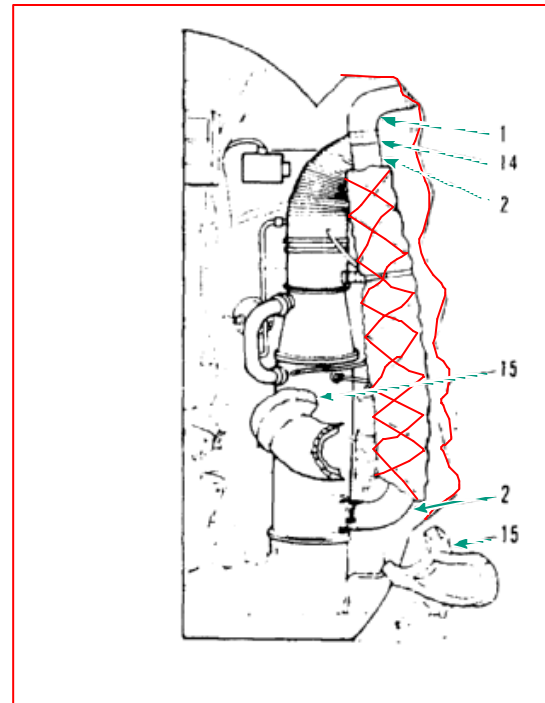

END OF TASK

INITIAL SETUP

**Applicable Configurations:**

All

**Tools:**

Aircraft Mechanic's Tool Kit, NSN 5180-00-323-4692

**Materials:**

Paper Tags (E264)  
Tape (E385)

**Personnel Required:**

Medium Helicopter Repairer

**Equipment Condition:**

Battery Disconnected (Task 1-39)  
Electrical Power Off  
Hydraulic Power Off  
Heater Removed (Task 13-2)

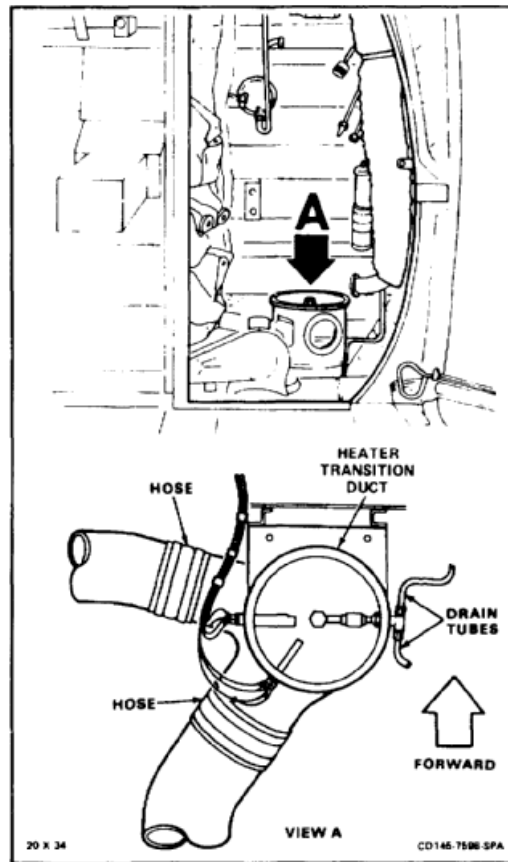

1. Tag and disconnect wires (1) from three thermostatic switches (2, 3, and 4). Tape ends of wires. Use tape (E385).
2. Disconnect drain tubes (5 and 6) from tee (7).

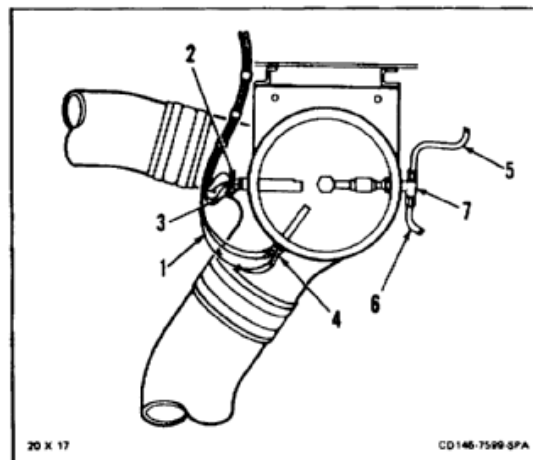

**13-22 REMOVE HEATER TRANSITION DUCT (Continued)**

13-22

3. Remove clamps (8 and 9) from hoses (10 and 11).
4. Remove four bolts (12) and washers (13).  
Remove heater transition duct (14).

***FOLLOW-ON MAINTENANCE:***

None

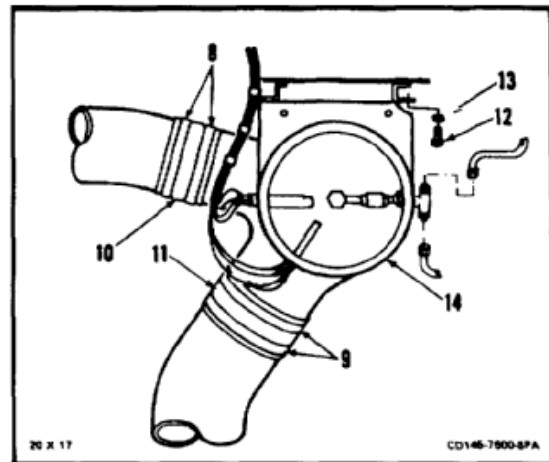

END OF TASK

INITIAL SETUP

**Applicable Configurations:**

All

**Tools:**

Aircraft Mechanic's Tool Kit, NSN 5180-00-323-4692

**Materials:**

None

**Personnel Required:**

Medium Helicopter Repairer

**References:**

TM 55-1520-240-23P

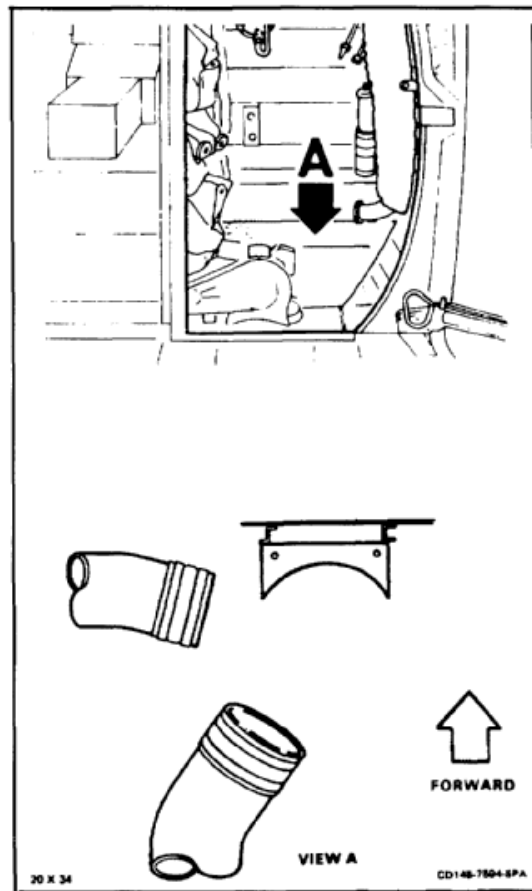

1. Position heater transition duct (1) with outlets (2 and 3) in hoses (4 and 5). Install four bolts (6) and washers (7).
2. Install clamps (8 and 9) on hoses (4 and 5).

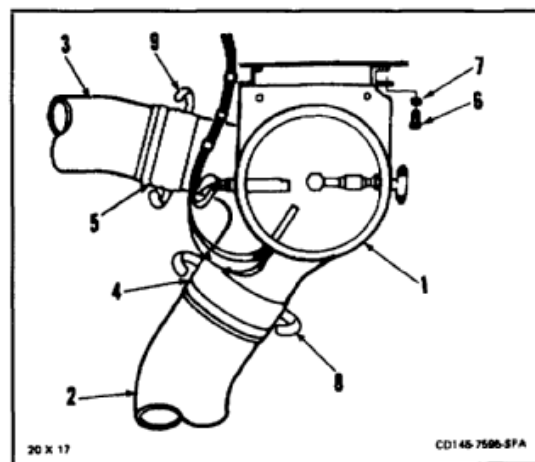



**13-23 INSTALL HEATER TRANSITION DUCT (Continued)****13-23**

3. Connect drain tubes (10 and 11) to tee (12).
4. Remove tape from ends of wires (13).
5. Connect wires (13) to three thermostatic switches (14, 15, and 16). Remove tags.

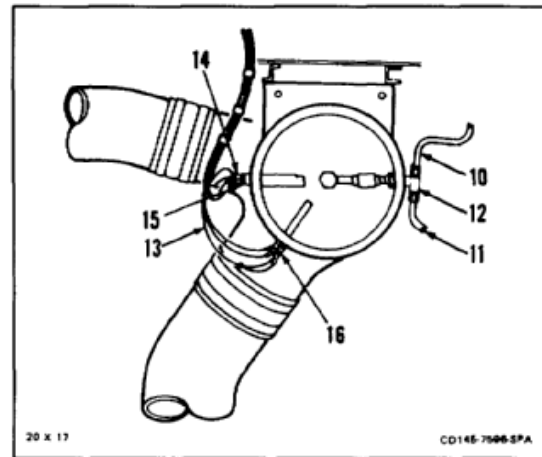
***FOLLOW-ON MAINTENANCE:***

Install heater (Task 13-8).

END OF TASK

INITIAL SETUP

**Applicable Configurations:**

All

**Tools:**

Aircraft Mechanic's Tool Kit, NSN 5180-00-323-4692

**Materials:**

None

**Personnel Required:**

Medium Helicopter Repairer (2)

**Equipment Condition:**

Battery Disconnected (Task 1-39)  
 Electrical Power Off  
 Hydraulic Power Off

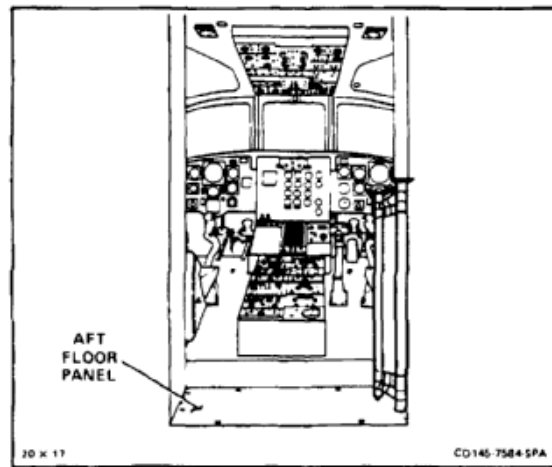

1. Have helper hold troop commanders seat (1) in horizontal position.
2. Remove nine screws (2).
3. Tilt floor panel (3) as needed to clear structure. Remove panel.
4. Lower seat (1) to stowed position.

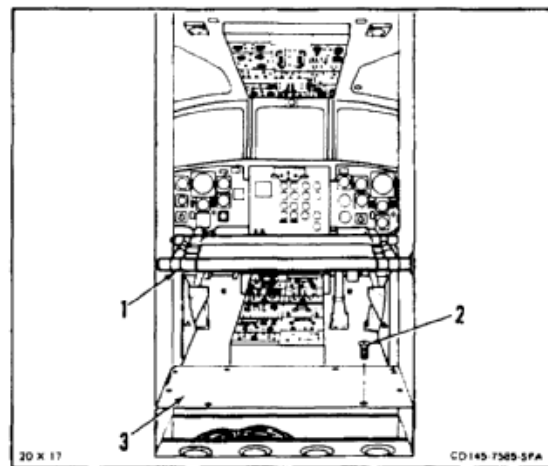

5. Remove 22 screws (4) and washers (5) from access panel (6).
6. Remove access panel (6).

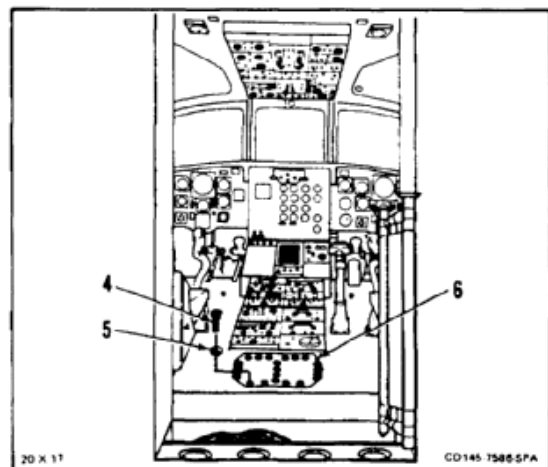

**13-24 REMOVE DISTRIBUTOR AIR DUCT (Continued)****13-24**

7. Remove four clamps (4, 5, and 6).
8. Slide hoses (7) clear of joint between distributor air duct (8) and valve (9).
9. Remove distributor air duct (8).

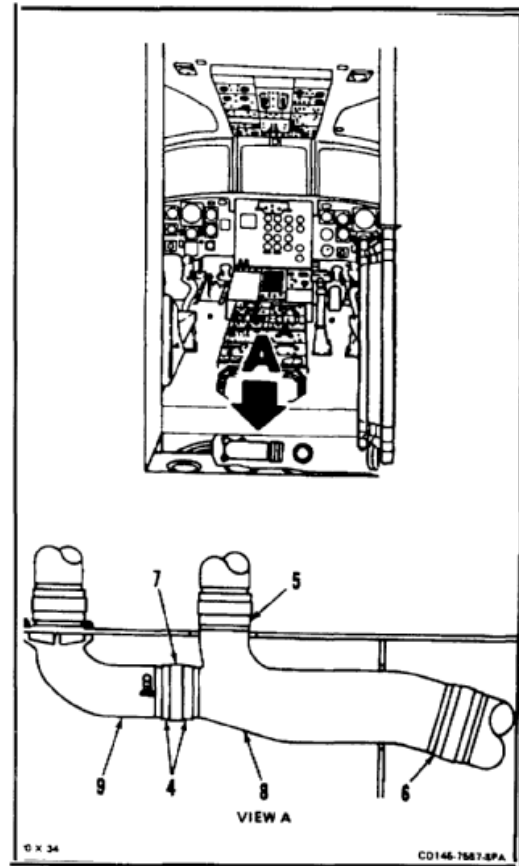
**FOLLOW-ON MAINTENANCE:**

None

END OF TASK

13-87

INITIAL SETUP

**Applicable Configurations:**

All

**Tools:**

Aircraft Mechanic's Tool Kit, NSN 5180-00-323-4692

**Materials:**

None

**Personnel Required:**

Medium Helicopter Repairer

**References:**

TM 55-1520-240-23P

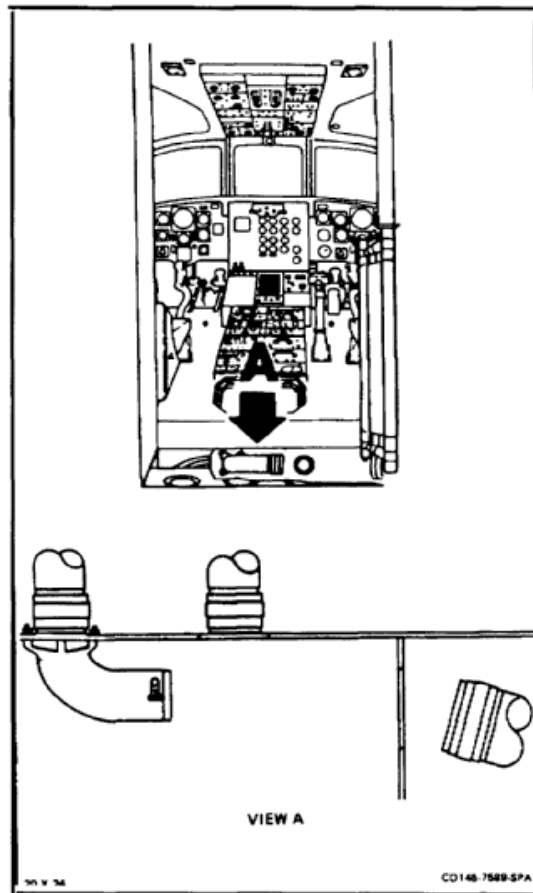

1. Position air duct (1) with outlets (2 and 3) in hoses (4 and 5).
2. Slide hoses (6) over outlet (3) of distributor air duct (1).
3. Install four clamps (8, 9, and 10).

**INSPECT**

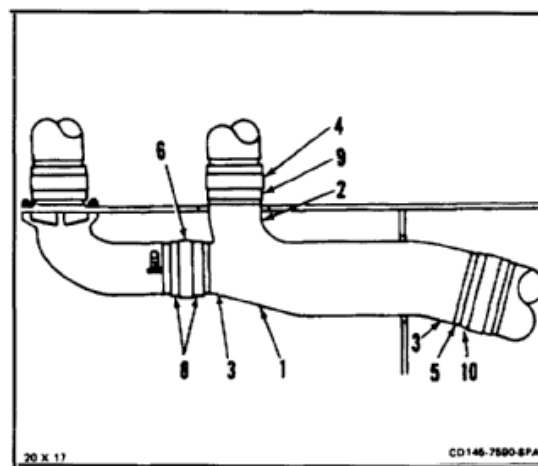

4. Install 22 screws (11), washers (12), and access panel (13).

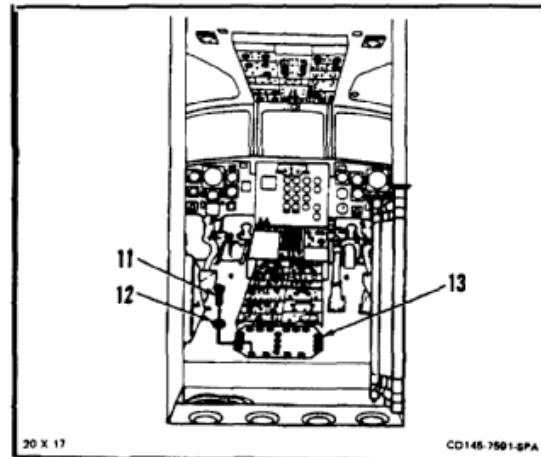

5. Have helper hold troop commanders seat (14) in horizontal position.
6. Position floor panel (15) on structure (16). Install nine screws (17).
7. Lower seat (14) to stowed position.

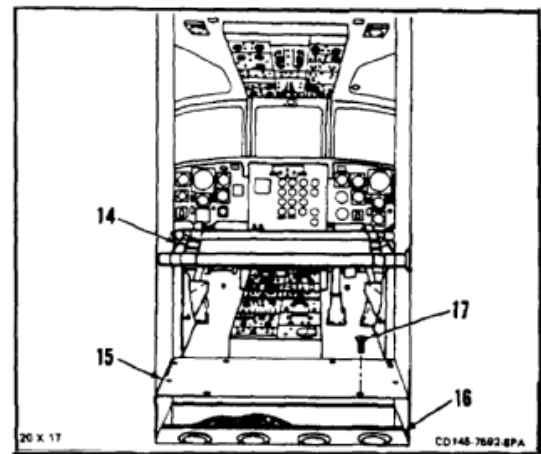

**FOLLOW-ON MAINTENANCE:**

None

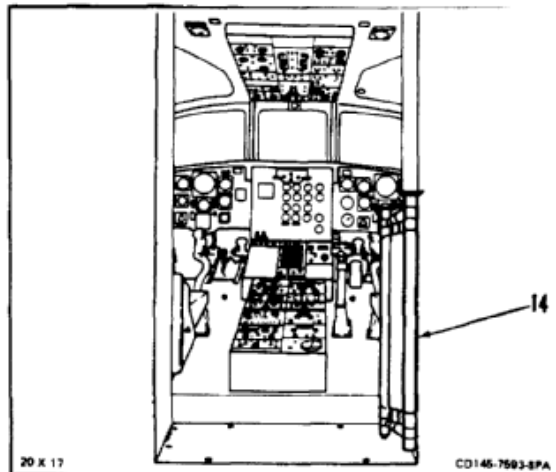

END OF TASK

INITIAL SETUP

**Applicable Configurations:**

All

**Tools:**

Aircraft Mechanic's Tool Kit, NSN 5180-00-323-4692

**Materials:**

None

**Personnel Required:**

Medium Helicopter Repairer (2)

**Equipment Condition:**

- Battery Disconnected (Task 1-39)
- Electrical Power Off
- Hydraulic Power Off
- Cockpit Aft Floor Removed (Task 2-83)

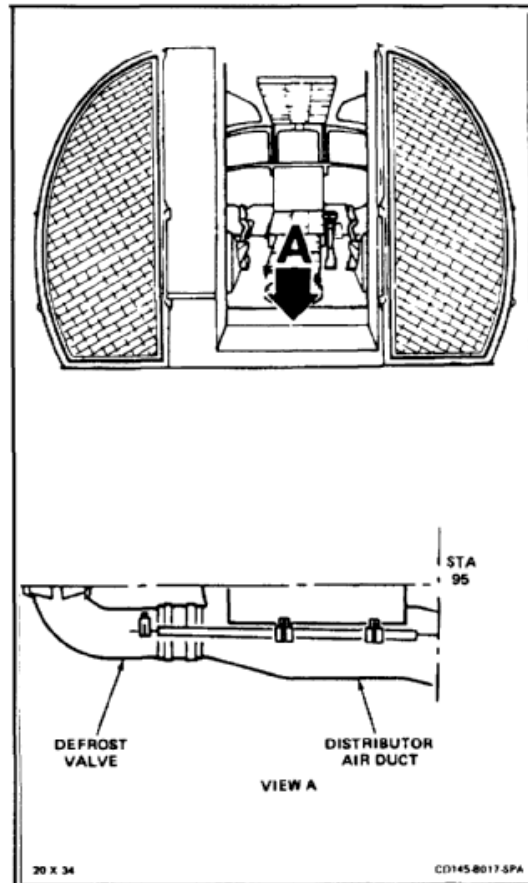

1. Remove 22 screws (1) and washer (2) from cockpit aft floor access panel (3). Remove panel.

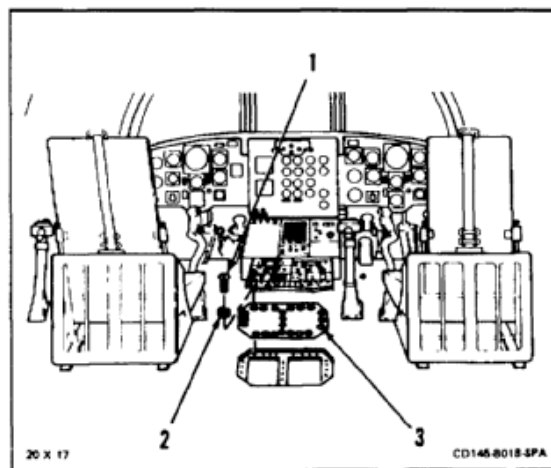

2. Loosen clamp (4).
3. With aid of helper, remove three nuts (5), washers (6), and bolts (7).

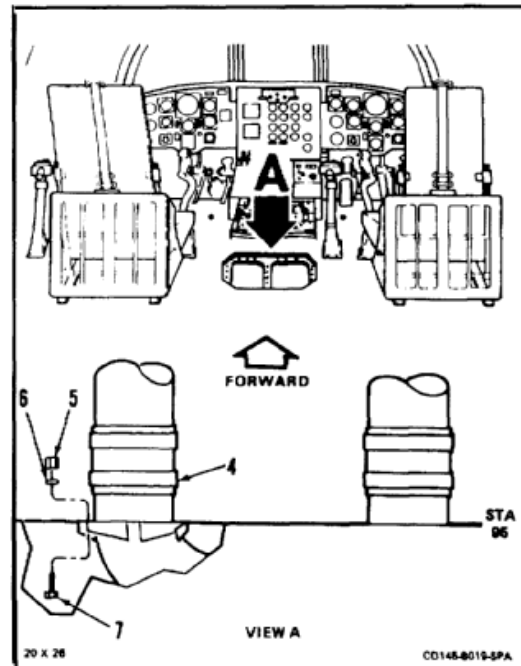

4. Loosen cable clamping nut (8) on defrost valve (9). Remove cockpit defrost control cable (10).
5. Loosen two clamps (11). Slide hose (12) to clear joint.
6. Remove valve (9).
7. Remove hose (12).

**FOLLOW-ON MAINTENANCE:**

None

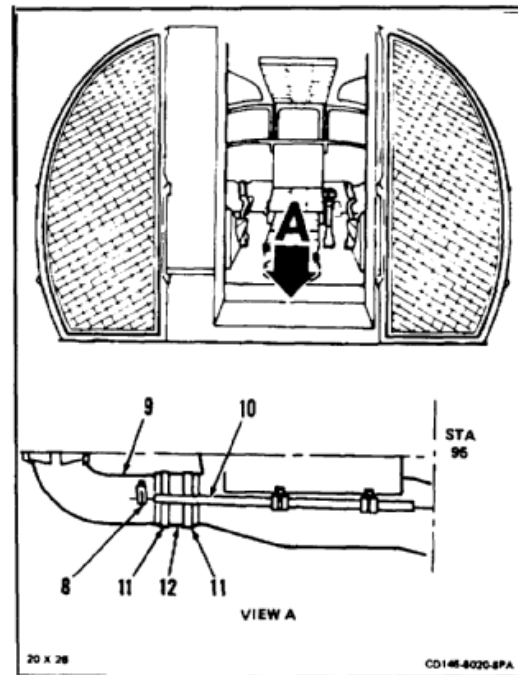

END OF TASK

INITIAL SETUP

**Applicable Configurations:**

All

**Tools:**

Aircraft Mechanic's Tool Kit, NSN 5180-00-323-4692

**Materials:**

None

**Personnel Required:**

Medium Helicopter Repairer (2)  
Inspector

**References:**

TM 55-1520-240-23P

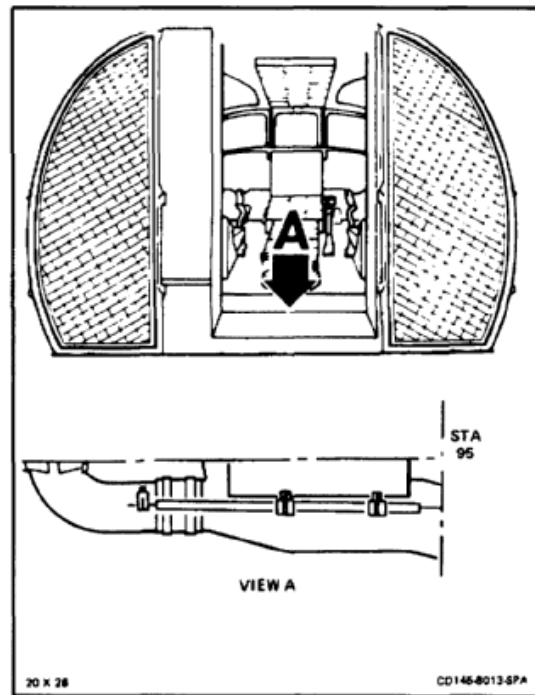

1. Slide hose (1) on defrost valve (2).
2. Insert defrost valve (2) into hose (3).
3. Align mount holes in valve (2) and sta. 95. With aid of helper, install three bolts (4), washers (5), and nuts (6).
4. Tighten clamp (7).

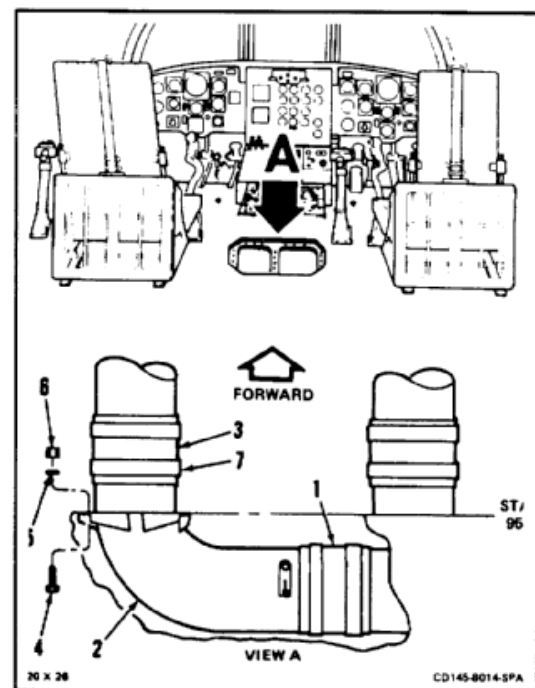



**13-27 INSTALL DEFROST VALVE (Continued)**

13-27

5. Slide hose (1) over joint between valve (2) and distributor duct (8). Install two clamps (9).
6. Insert cockpit defrost control cable (10) in cable clamping nut (11).
7. Have helper, in cockpit, hold cockpit defrost control handle (12) in a position  $1/16$  to  $1/8$  inch short of fully closed.
8. Hold valve (2) fully closed. Tighten clamping nut (11).
9. Have helper operate handle (12). Check that valve (2) opens and closes.

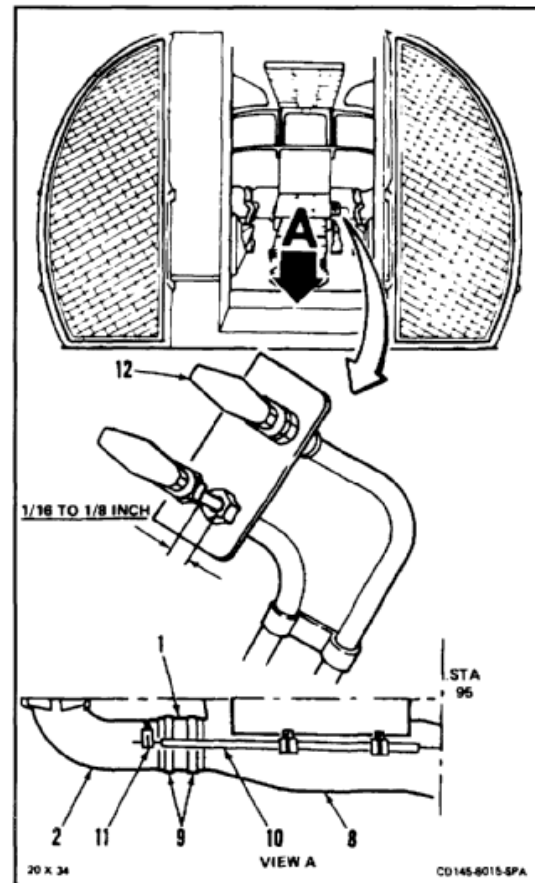
**INSPECT**

10. Position aft floor access panel (13) in cockpit. Install 22 screws (14) and washers (15).

**FOLLOW-ON MAINTENANCE:**

Install cockpit aft floor (Task 2-84).

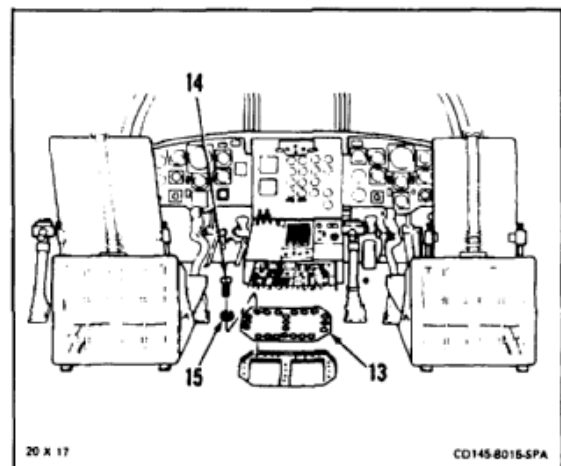

END OF TASK

## INITIAL SETUP

**Applicable Configurations:**

All

**Tools:**

Aircraft Mechanic's Tool Kit, NSN 5180-00-323-4692

**Materials:**

None

**Personnel Required:**

Medium Helicopter Repairer

**Equipment Condition:**

- Battery Disconnected (Task 1-39)
- Electrical Power Off
- Hydraulic Power Off
- Cockpit Ducting Access Panel Removed (Task 2-2)
- Pilot's and Copilot's Jettisonable Door Removed (Task 2-86)
- Pilot's and Copilot's Seat Removed (Task 2-111)
- Pilot's and Copilot's Floor Access Panel Removed (Task 2-79)
- Cockpit Dynamic Absorber Removed (Task 2-145)
- Pilot's and Copilot's Landing Light Removed (Task 9-69)

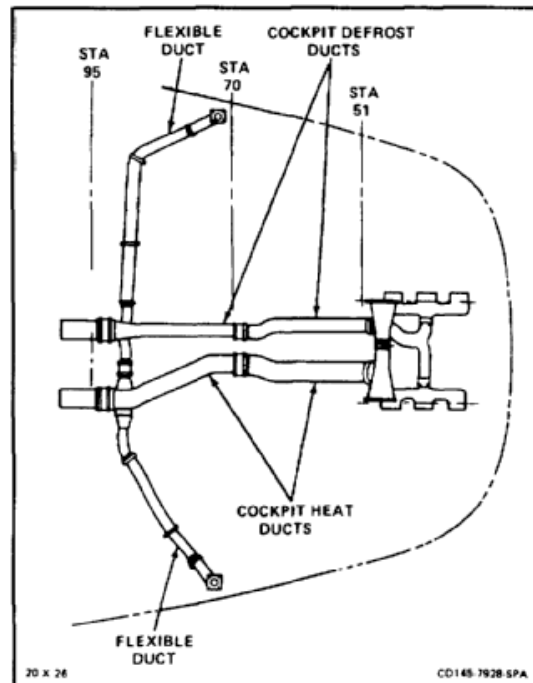

1. Loosen four clamps (1). Slide two hoses (2) aft onto defrost duct (3) and heat duct (4) to clear joints between ducts.

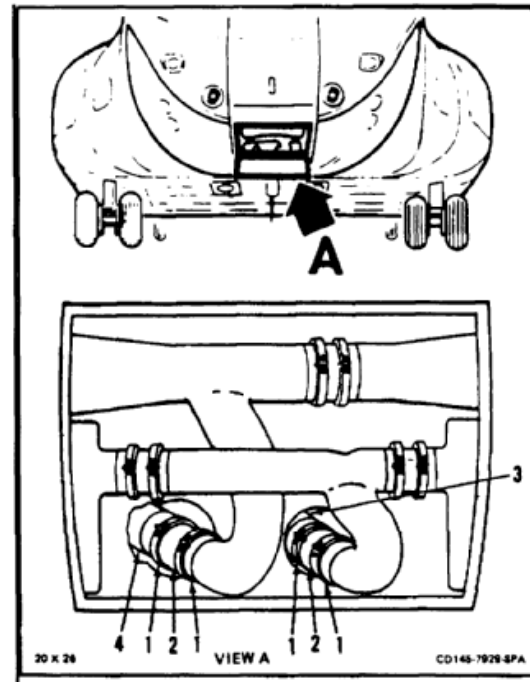

2. Loosen four clamps (5). Slide two hoses (6) forward onto defrost duct (7) and heat duct (8).
3. Remove ducts (7 and 8). Remove four clamps (5) and two hoses (6) from each duct.

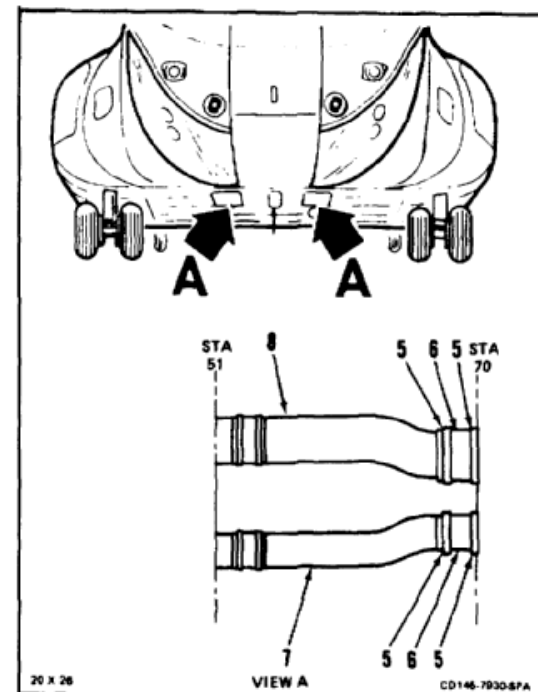

4. Loosen two clamps (9). Slide hose (10) forward onto defrost duct (11).
5. Loosen clamp (12). Remove flex duct (13) from defrost duct (11).
6. Loosen two clamps (14). Slide hose (15) onto defrost duct (11).
7. Remove defrost duct (11). Remove clamps (9 and 14) and hoses (10 and 15).
8. Loosen two clamps (16). Slide hose (17) forward onto heat duct (18).
9. Remove heat duct (18). Remove clamps (16) and hose (17).

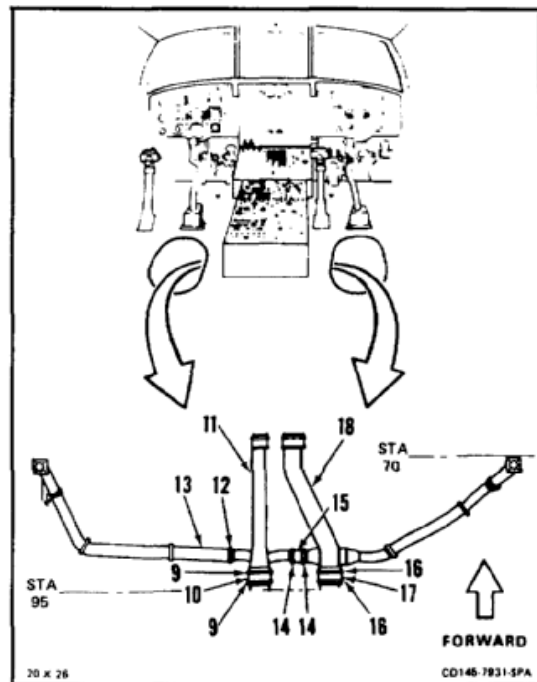

**13-28 REMOVE COCKPIT DUCTING (Continued)**

13-28

10. Loosen clamp (19). Remove defrost duct (20).
11. Remove three support clamps (21).
12. Loosen two clamps (22). Remove defrost hoses (23 and 24). Remove clamp (12, 19, and 22).
13. Remove support clamp (25).
14. Remove four nuts (26), washers (27), and screws (28) from each defrost duct (29 and 30). Remove ducts.

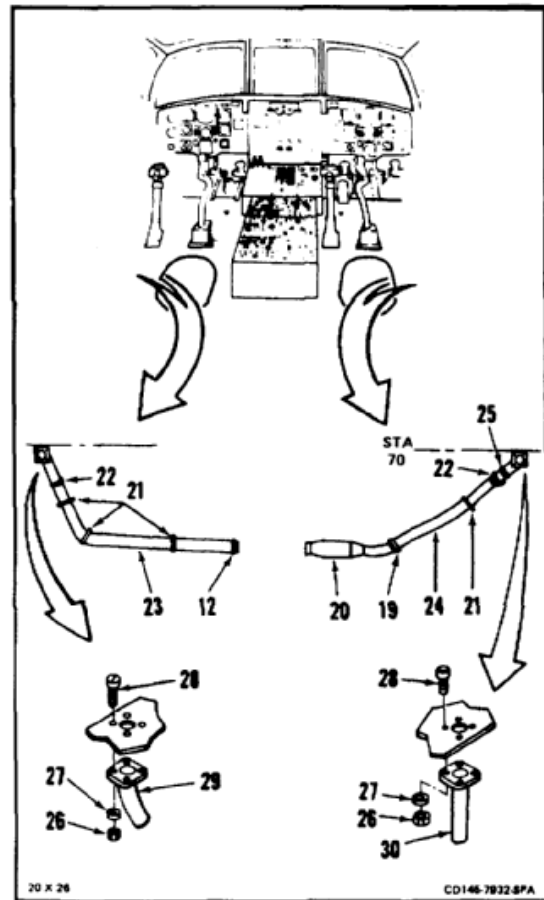
**FOLLOW-ON MAINTENANCE:**

None

END OF TASK

INITIAL SETUP

**Applicable Configurations:**

All

**Tools:**

Aircraft Mechanic's Tool Kit, NSN 5180-00-323-4692

**Materials:**

None

**Personnel Required:**

Medium Helicopter Repairer  
Inspector

**References:**

TM 55-1520-240-23P

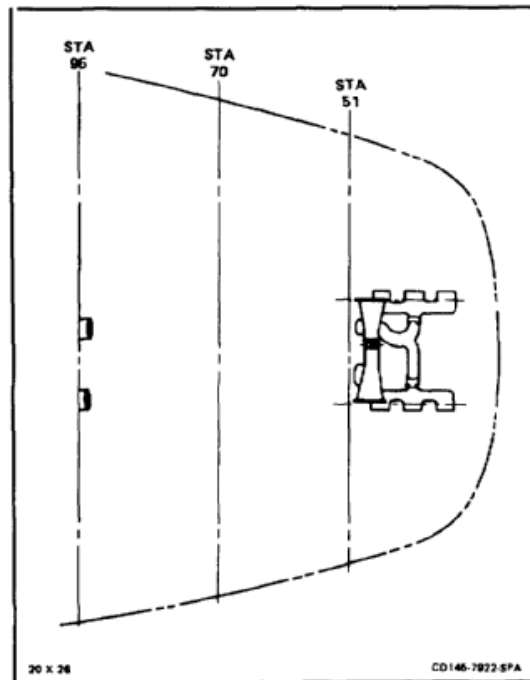

1. Align holes in flange of defrost ducts (1 and 2) with holes in cabin floor (3).
2. Install four screws (4), washers (5), and nuts (6) in each duct (1 and 2).
3. Install support clamp (7).

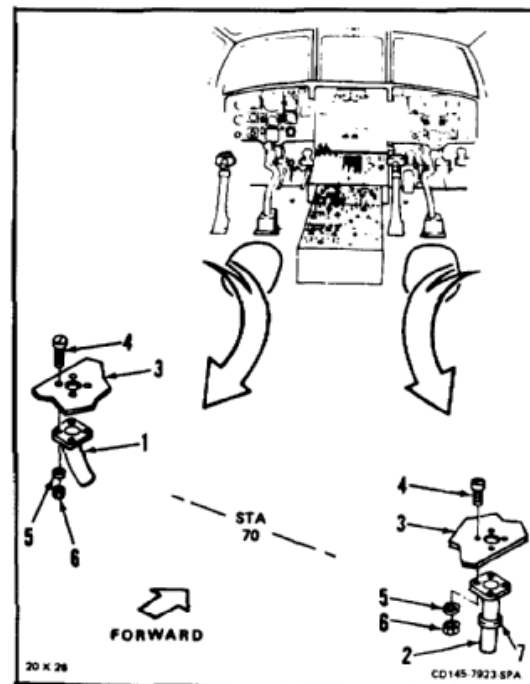

4. Install defrost hoses (8 and 9) on ducts (1 and 2). Install two clamps (10).
5. Install defrost duct (11) in hose (9). Install clamp (12).
6. Install four support clamps (13).

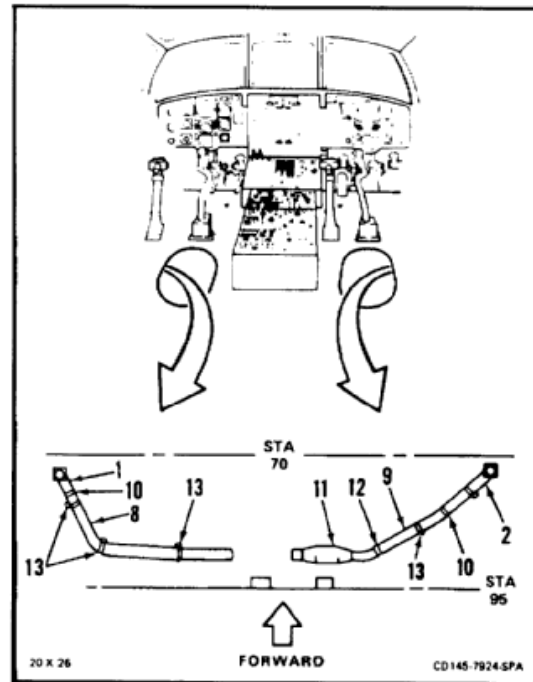

7. Slide hoses (14 and 15) onto defrost duct (16).
8. Position duct (16) between flex hose (8) and defrost duct (11). Slide hose (14) over joint between ducts (16 and 17). Install two clamps (18).
9. Slide hose (15) over joint between ducts (16 and 11). Install two clamps (19).
10. Slide flex hose (8) onto duct (16). Install clamp (20).
11. Slide hose (21) onto heat duct (22).
12. Position heat duct (22) on distributor duct (23). Slide hose (21) over joint between ducts. Install two clamps (24).

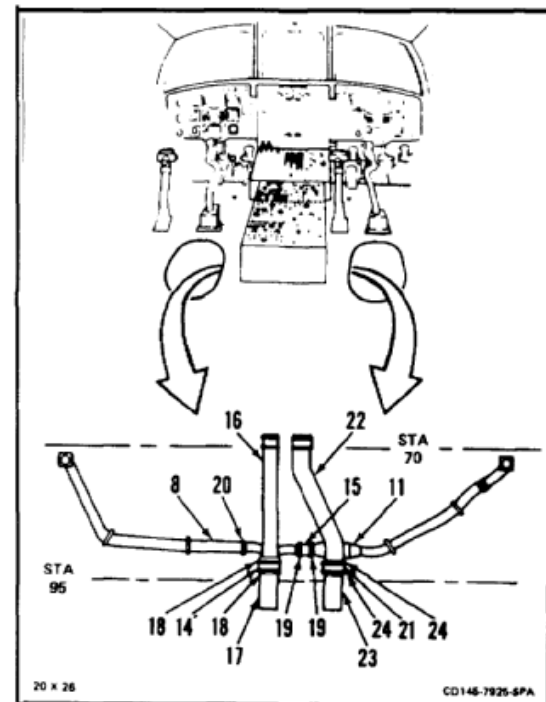

13. Slide hoses (25 and 26) on heat duct (27).
14. Position heat duct (27) on duct (22). Slide hose (25) over joint between ducts. Install two clamps (28).
15. Slide hoses (29 and 30) on defrost duct (31).
16. Position duct (31) on duct (16). Slide hose (29) over joint between ducts. Install two clamps (32).

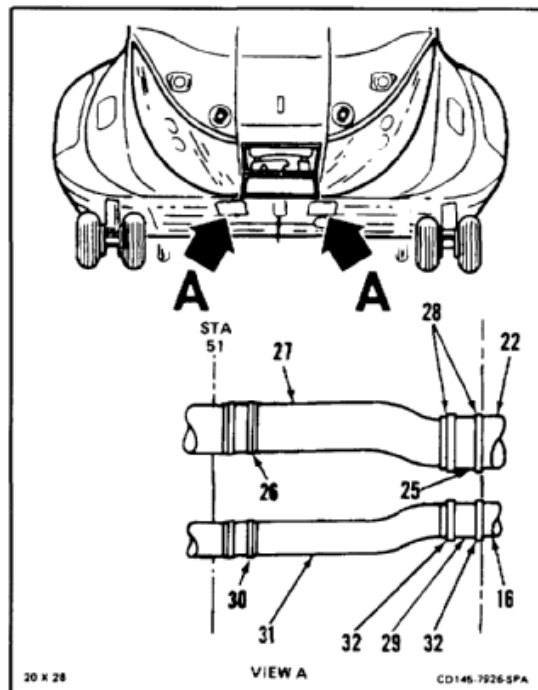

17. Align heat duct (27) and heat outlet duct (33). Slide hose (26) over joint between ducts. Install two clamps (34).
18. Align defrost duct (31) with defrost diffuser duct (35). Slide hose (30) over joint between ducts. Install two clamps (36).

**FOLLOW-ON MAINTENANCE:**

- Install cockpit dynamic absorber (Task 2-146).
- Install pilot's and copilot's floor access panel (Task 2-80).
- Install pilot's and copilot's seat (Task 2-114).
- Install pilot's and copilot's jettisonable doors (Task 2-89).
- Install pilot's and copilot's landing light (Task 9-79).
- Install cockpit ducting access panel (Task 2-2).

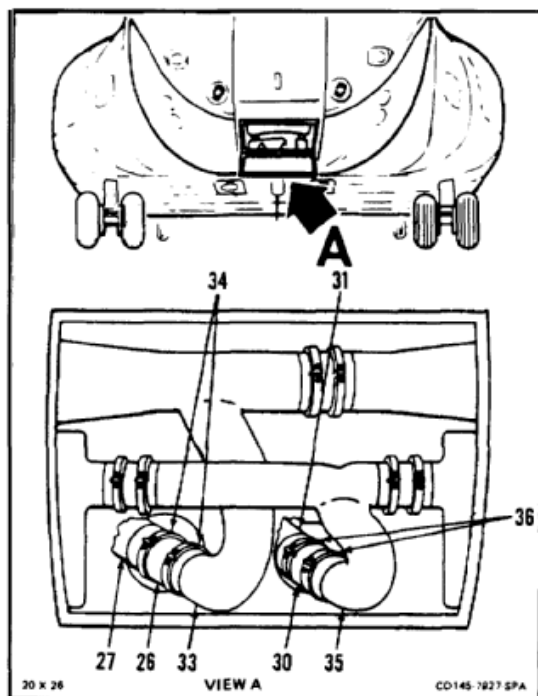

END OF TASK



**13-30 REMOVE COCKPIT AIR OUTLET DUCT**

13-30

**INITIAL SETUP**

**Applicable Configurations:**

All

**Tools:**

Aircraft Mechanic's Tool Kit, NSN 51 80-00-323-4692

**Materials:**

None

**Personnel Required:**

Medium Helicopter Repairer (2)

**Equipment Condition:**

- Battery Disconnected (Task 1-39)
- Electrical Power Off
- Hydraulic Power Off
- Cockpit Ducting Access Panel Removed (Task 2-2)
- Nose Enclosure Air Diffusers Removed (Task 13-32)

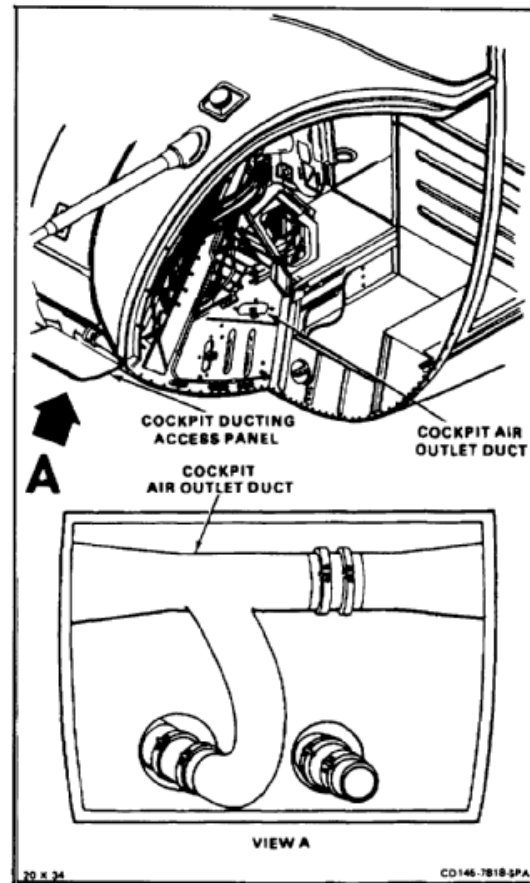

1. Have helper in cockpit disconnect control cable (1) from air outlet duct flap (2) at each side of cockpit beam assembly (3).

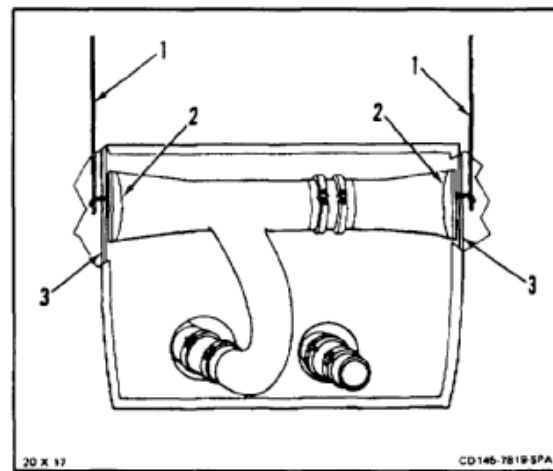

2. Loosen two clamps (4) on hose (5).
3. Slide hose (5) to clear air outlet duct (6) and air conditioning duct (7).
4. Have helper in cockpit hold screws (8).
5. Remove eight nuts (9) and washers (10).
6. Remove screws (8).
7. Remove air outlet duct (6) and two gaskets (11).

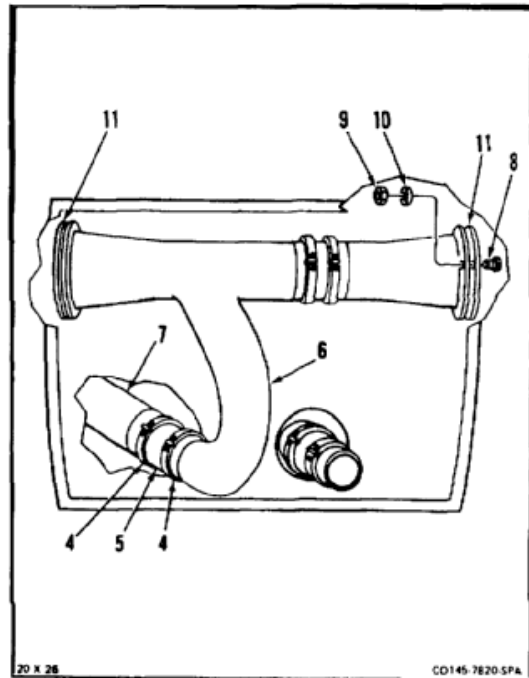

8. Remove two clamps (12) from hose (13). Separate air outlet ducts (6 and 14).
9. Remove hose (13).

**FOLLOW-ON MAINTENANCE:**

None

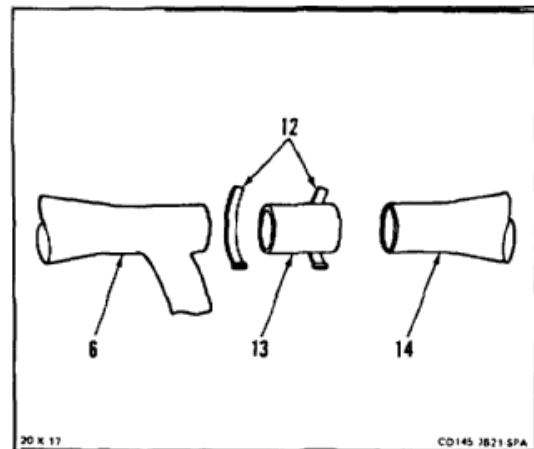

END OF TASK

INITIAL SETUP

**Applicable Configurations:**

All

**Tools:**

Aircraft Mechanic's Tool Kit, NSN 5180-00-323-4692

**Materials:**

None

**Personnel Required:**

CH-47 Helicopter Repairer (2)  
Inspector

**References:**

TM 55-1520-240-23P

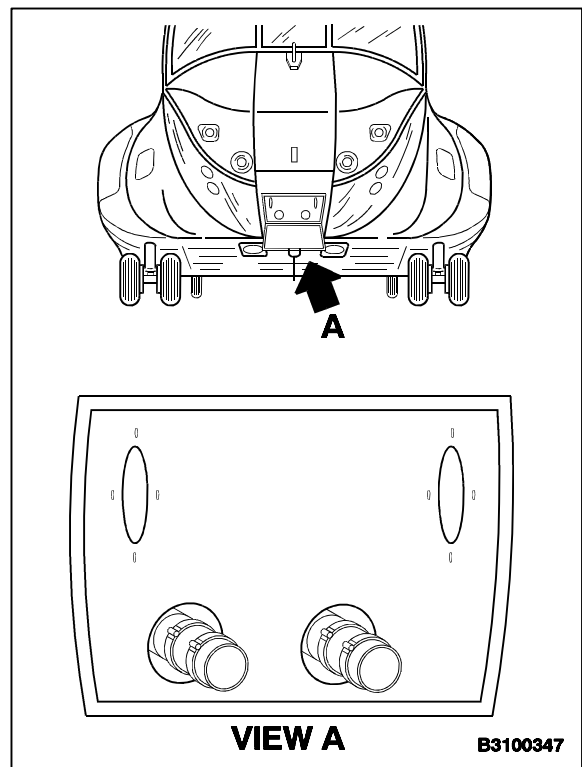

1. Install air outlet ducts (1 and 2) in hose (3). Loosely install two clamps (4) on hose.

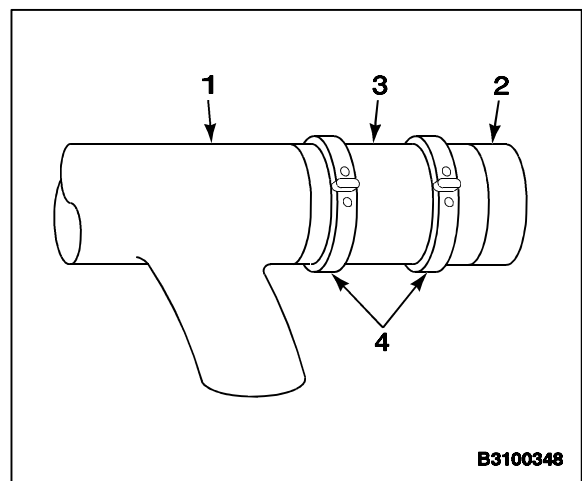

2. Align hose in outlet duct flanges (5) and beams (6).
3. Insert gaskets (7) between flanges (5) and beams (6).
4. Have helper, in cockpit, install eight screws (8).
5. Install eight washers (9) and nuts (10).
6. Slide hose (11) over outlet duct (1) and air conditioning duct (12). Tighten clamps (13).

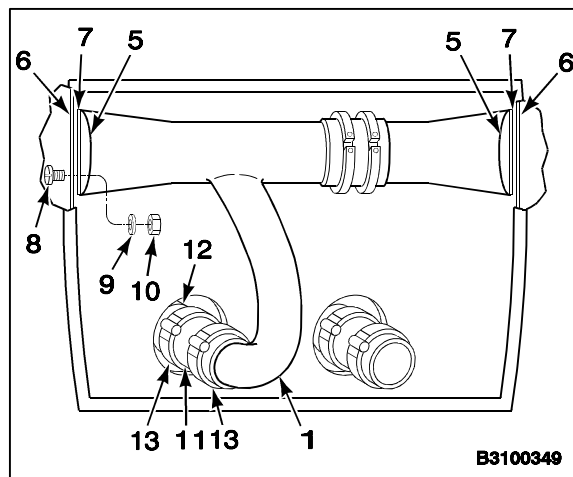

7. Tighten clamps (4) on hose (3).
8. Connect control cables (14) on outlet duct flaps (15).

**INSPECT**

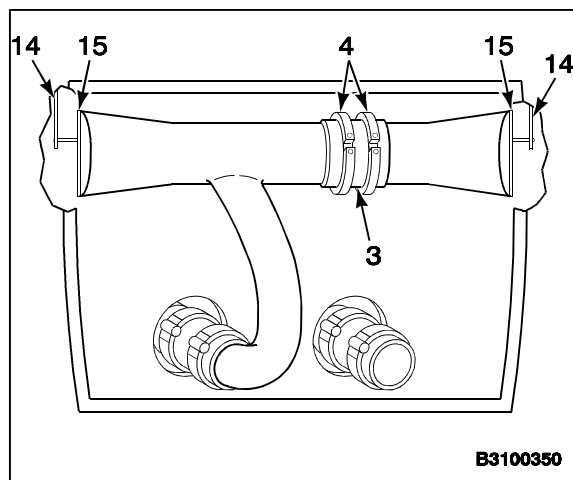

**FOLLOW-ON MAINTENANCE:**

- Install nose enclosure air diffuser (Task 13-33).
- Install ducting access panel (Task 2-2).

END OF TASK

INITIAL SETUP

**Applicable Configurations:**

All

**Tools:**

Aircraft Mechanic's Tool Kit, NSN 51 80-00-323-4692

**Materials:**

None

**Personnel Required:**

Medium Helicopter Repairer (2)

**Equipment Condition:**

- Battery Disconnected (Task 1-39)
- Electrical Power Off
- Hydraulic Power Off
- Nose Compartment Access Door Opened (Task 2-2)
- Cockpit Ducting Access Panel Removed (Task 2-2)

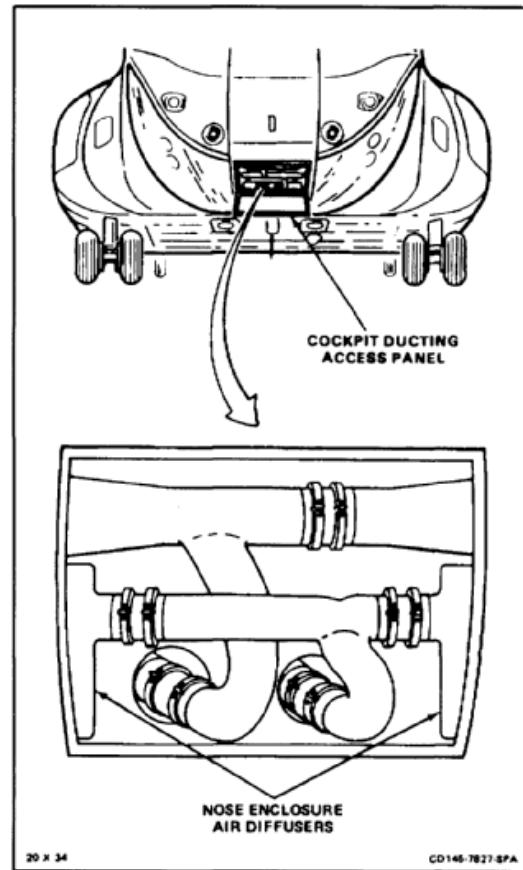

1. Loosen five clamps (1).
2. Slide two hoses (2) to clear joints between air diffusers (3) and defroster duct (4).
3. Remove defroster duct (4).

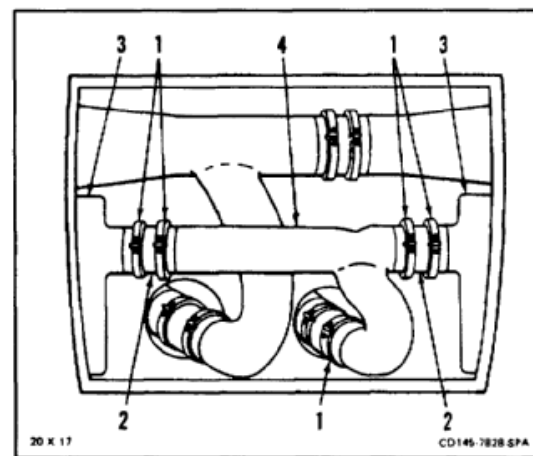

4. Have helper in cockpit hold six screws (5).
5. Remove six washers (6) and nuts (7). Remove screws (5).
6. Remove two diffusers (3).

***FOLLOW-ON MAINTENANCE:***

None

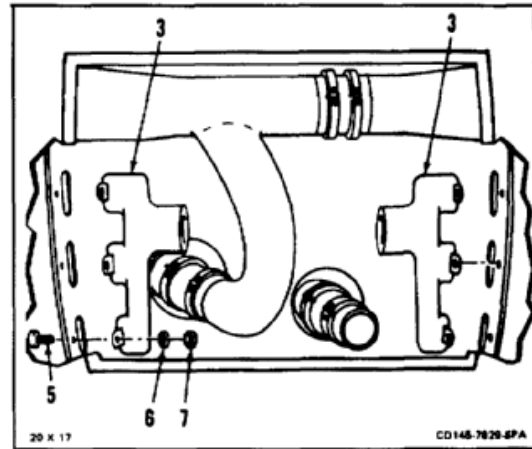

END OF TASK

INITIAL SETUP

**Applicable Configurations:**

All

**Tools:**

Aircraft Mechanic's Tool Kit, NSN 51 80-00-323-4692

**Materials:**

None

**Personnel Required:**

Medium Helicopter Repairer (2)  
Inspector

**References:**

TM 55-1520-240-23P

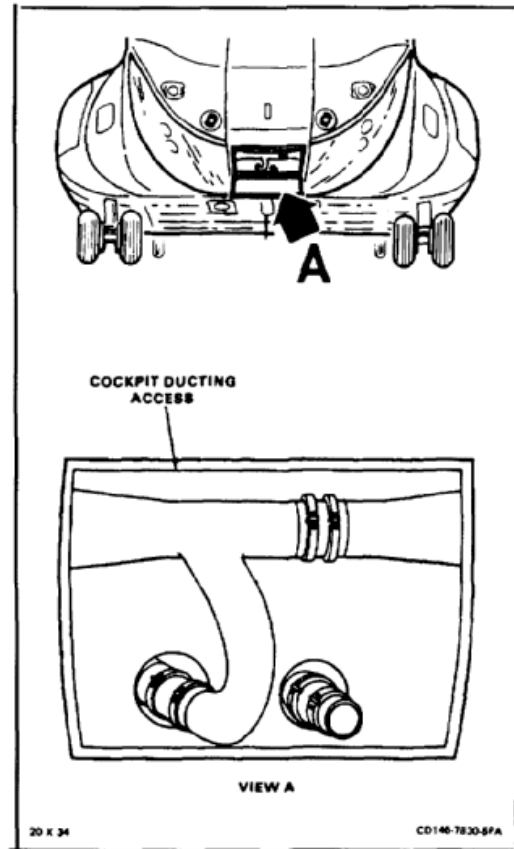

1. Position two diffusers (1) in beams (2).
2. Have helper in cockpit install three screws (3) in each diffuser (1).
3. Install three washers (4) and nuts (5) in each diffuser (1).

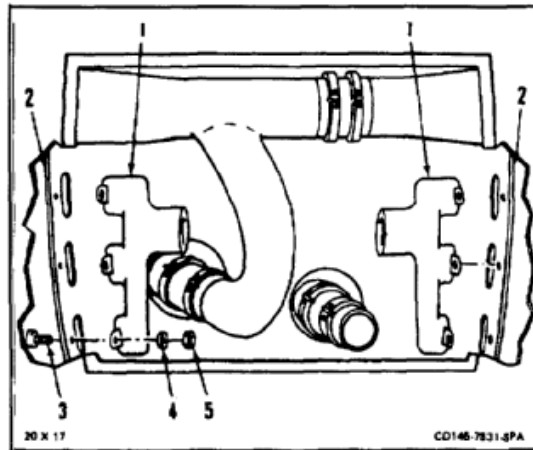

4. Install end of defroster duct (6) in hose (7).
5. Align remaining outlets of duct (6) with outlets in diffusers (1).
6. Slide two hoses (8) over joints between diffusers (1) and duct (6).
7. Tighten five clamps (9).

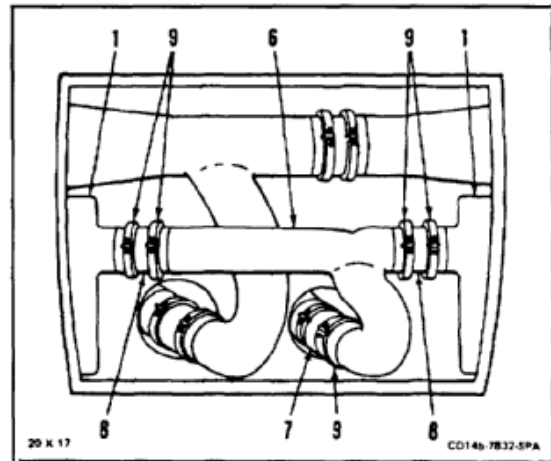
**INSPECT****FOLLOW-ON MAINTENANCE:**

Install cockpit ducting access panel (Task 2-2).

END OF TASK



## INITIAL SETUP

**Applicable Configurations:**

All

**Tools:**

Aircraft Mechanic's Tool Kit, NSN 51 80-00-323-4692

**Materials:**

Tape (E388)

**Personnel Required:**

Medium Helicopter Repairer

**Equipment Condition:**

Battery Disconnected (Task 1-39)  
 Electrical Power Off  
 Hydraulic Power Off

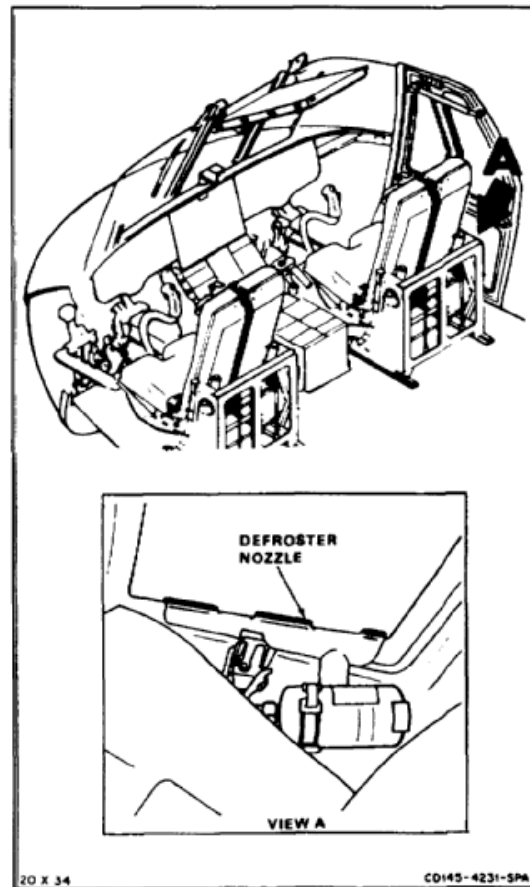
**NOTE**

Procedure is same to remove right or left side defroster nozzle. Right side (pilot's) nozzle is shown here.

1. Remove three screws (1) and washers (2).
2. Remove nozzle (3).
3. Cover duct outlet (4) with tape (E388).

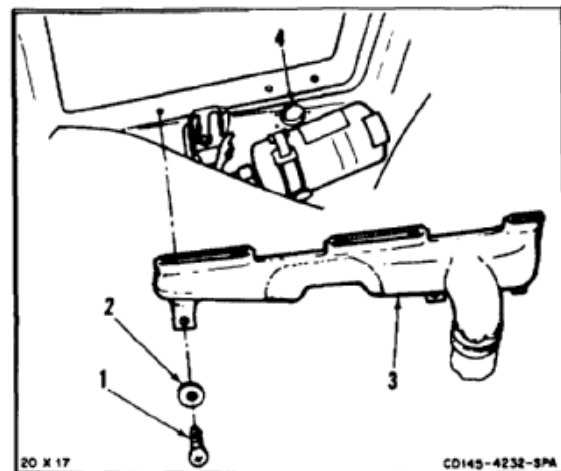

4. Remove clamp (5) from hose (6).
5. Remove hose (6) from nozzle (3).

**FOLLOW-ON MAINTENANCE:**

None

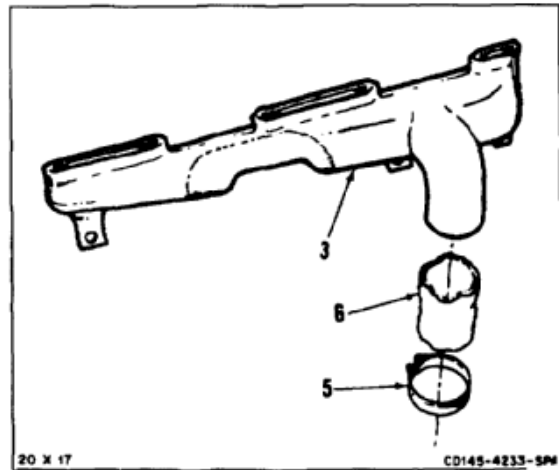

END OF TASK

13-110

INITIAL SETUP

**Applicable Configurations:**

All

**Tools:**

Aircraft Mechanic's Tool Kit, NSN 51 80-00-323-4692

**Materials:**

None

**Personnel Required:**

Medium Helicopter Repairer  
Inspector

**References:**

TM 55-1520-240-23P

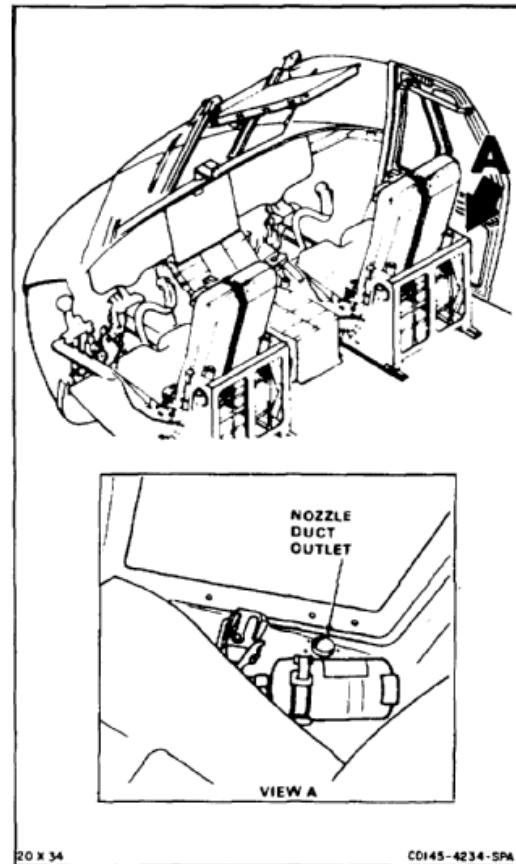

**NOTE**

Procedure is same to install right or left side defroster nozzle. Right side (pilot's) nozzle is shown here.

1. Install hose (1) on nozzle (2).
2. Install clamp (3) over hose (1).

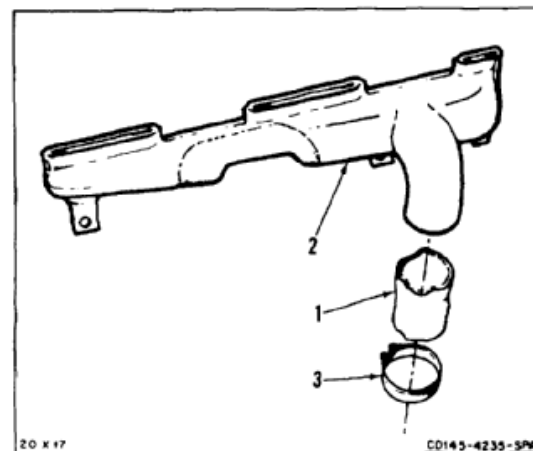

3. Remove tape from duct outlet (4).
4. Position hose (1) over duct outlet (4).
5. Install three screws (5) and washers (6).

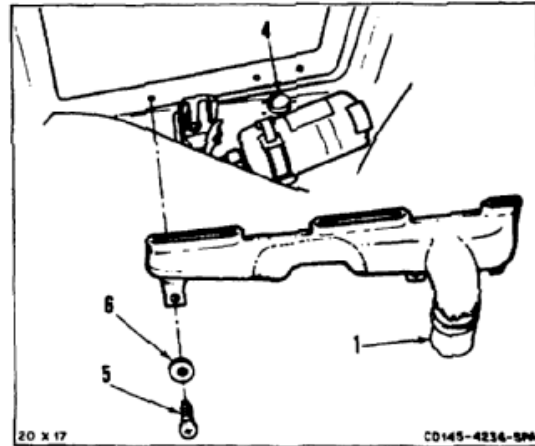
***INSPECT******FOLLOW-ON MAINTENANCE:***

None

END OF TASK

13-112

INITIAL SETUP

**Applicable Configurations:**

All

**Tools:**

Aircraft Mechanic's Tool Kit, NSN 5180-00-323-4692

**Materials:**

None

**Personnel Required:**

Medium Helicopter Repairer

**Equipment Condition:**

- Battery Disconnected (Task 1-39)
- Electrical Power Off
- Hydraulic Power Off
- Pilot's Seat Removed (Task 2-111)
- Pilot's Floor Access Panel Removed (Task 2-79)
- Cockpit Aft Floor Panel Removed (Task 2-83)
- Heater Compartment Acoustical Blanket Removed (Task 2-208)
- Pilot's Landing Light Removed (Task 9-69)

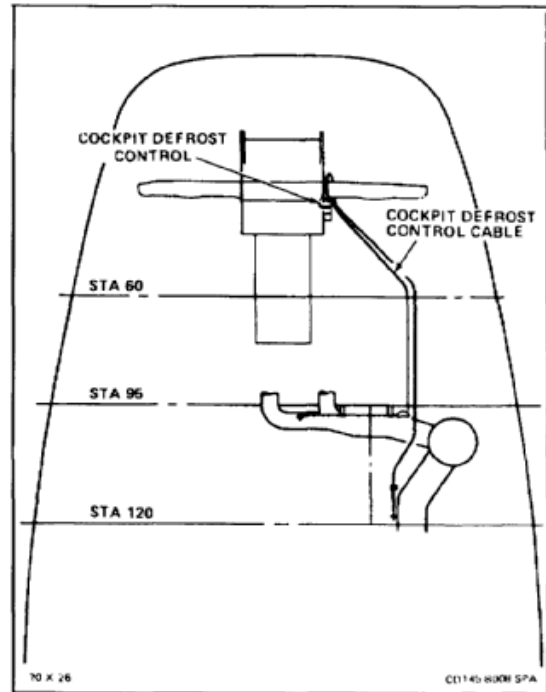

**REMOVE COCKPIT TRANSVERSE DEFROST CONTROL CABLE**

1. Loosen cable clamping nuts (1) on defrost valve (2) and bellcrank (3).
2. Remove defrost control cable (4) from transverse defrost control tube (5).

**REMOVE COCKPIT TRANSVERSE DEFROST CONTROL TUBE**

3. Loosen two clamps (6).
4. Remove tube (5).

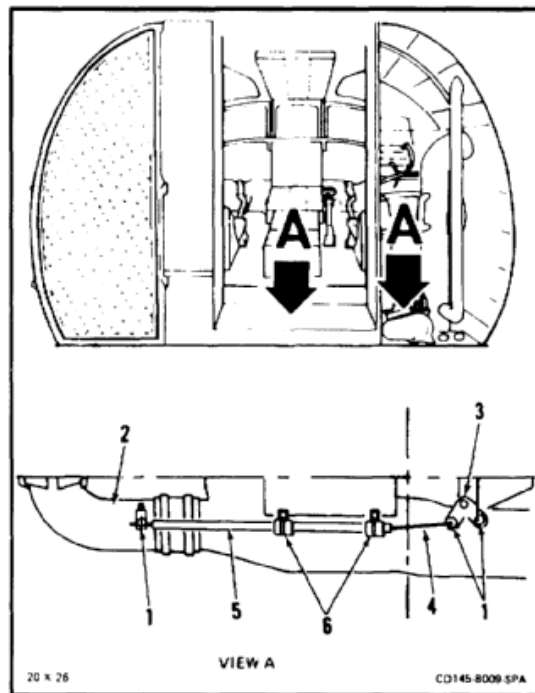

**REMOVE COCKPIT DEFROST CONTROL CABLE**

5. Pull handle (7) and remove cable (8).
6. Remove nut (9) and washer (10) from control (11).
7. Remove control (11) from mounting plate (12).
8. Loosen three clamps (13).

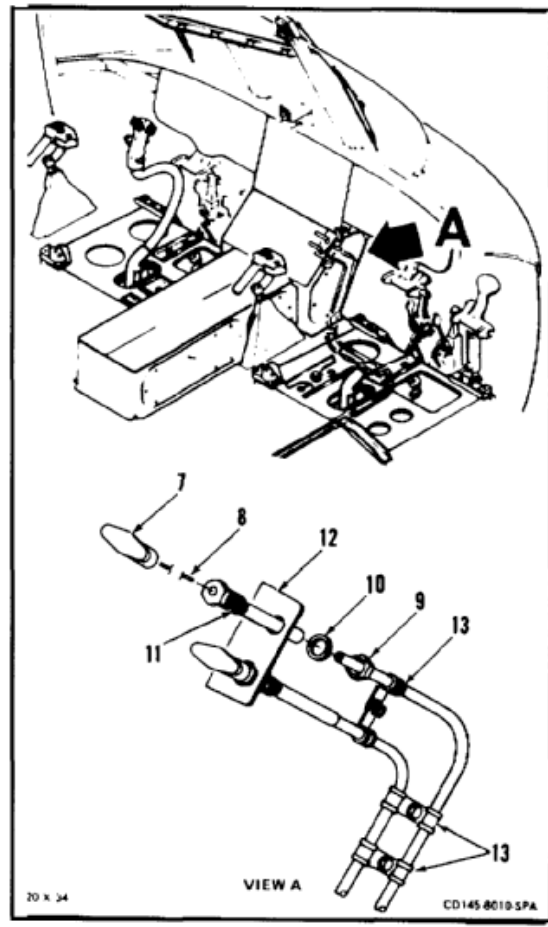

**REMOVE COCKPIT DEFROST CONTROL TUBE**

9. Loosen clamp (14) on defrost control tube (15).

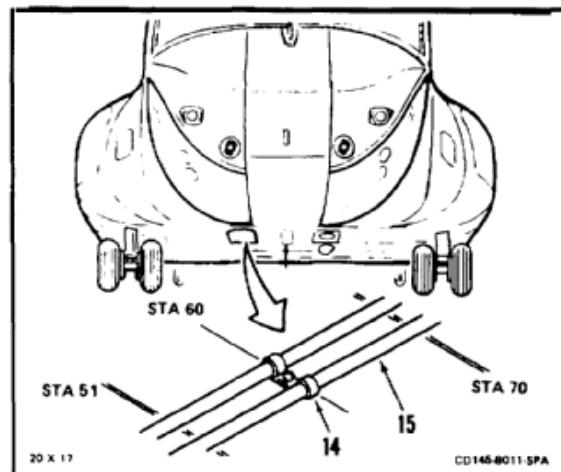

**13-36 REMOVE COCKPIT DEFROST CONTROL (Continued)****13-36**

10. Loosen two clamps (16).
11. Remove tube (15).

**FOLLOW-ON MAINTENANCE:**

None

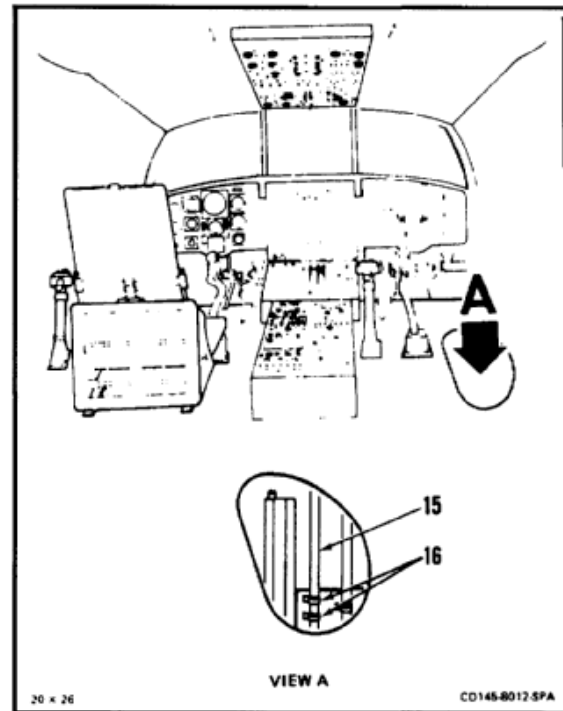

END OF TASK

INITIAL SETUP

**Applicable Configurations:**

All

**Tools:**

Aircraft Mechanic's Tool Kit, NSN 5180-00-323-4692

**Materials:**

None

**Personnel Required:**

Medium Helicopter Repairer (2)  
Inspector

**References:**

TM 55-1520-240-23P

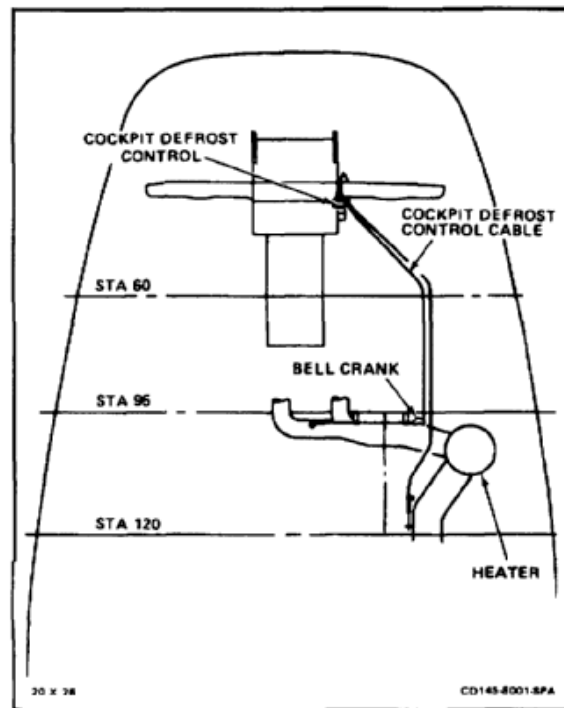

**INSTALL COCKPIT DEFROST CONTROL TUBE**

1. Position control (1) in mounting plate (2). Install washer (3) and nut (4).
2. Route control tube (5) through three clamps (6).
3. Insert end of tube (5) 1 inch into control (1).
4. Tighten three clamps (6).

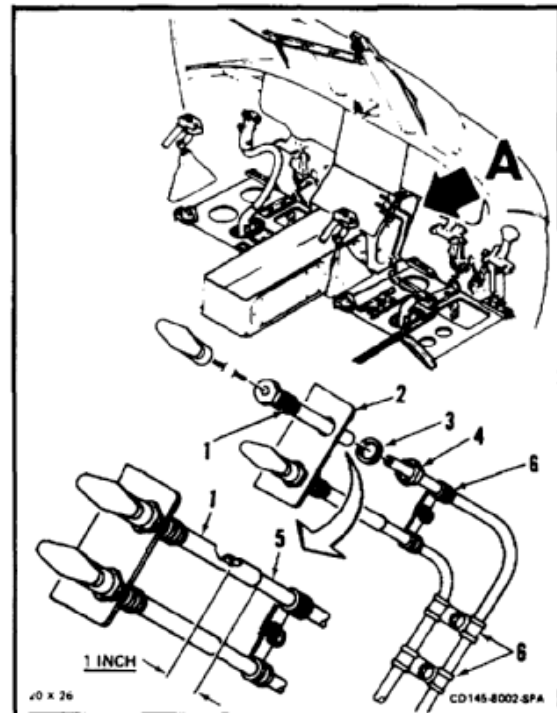



5. Route tube (5) through clamp (7). Tighten clamp.

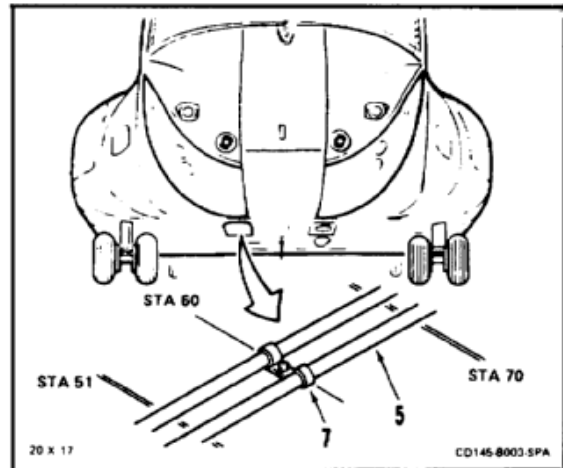

6. Route tube (5) through two clamps (8). Tighten clamps.

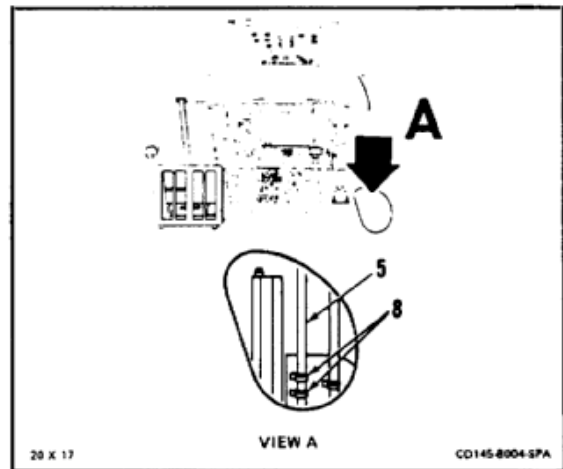

7. Thread defrost control cable (9) in tube (5).

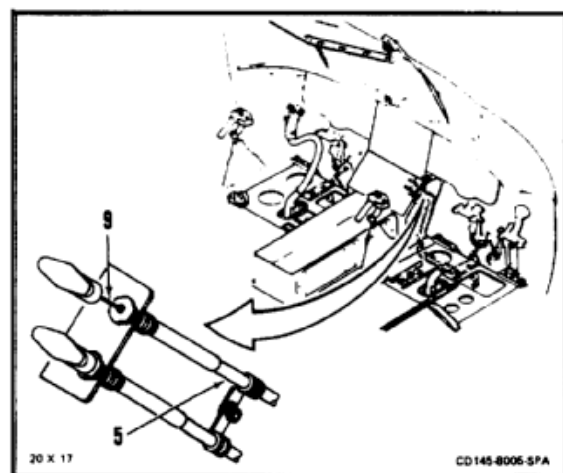

**INSTALL COCKPIT TRANSVERSE CONTROL TUBE**

8. Route tube (10) through two clamps (11).  
Tighten clamps.

**INSTALL COCKPIT TRANSVERSE CONTROL CABLE**

9. Thread control cable (12) through tube (10).
10. Insert ends of cable (12) in cable clamping nuts (13) on bellcrank (14) and defrost valve (15).
11. Insert end of cable (9) in cable clamping nut (16).
12. Position bellcrank (14) with cable clamping nuts (13 and 16) parallel to sta. 95.
13. Hold defrost valve (15) fully closed. Tighten two nuts (13).

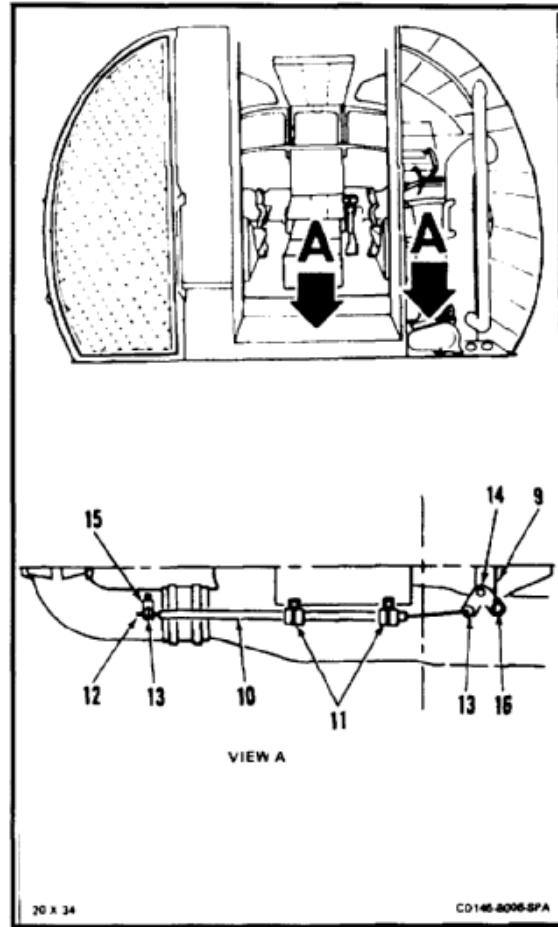

**13-37 INSTALL COCKPIT DEFROST CONTROL (Continued)**

13-37

14. Have helper, in cockpit, position defrost control handle (17) **1/8 to 1/16 inch** short of fully closed.
15. Check that bellcrank (14) is parallel to sta. 95. Hold bellcrank and tighten nut (16).
16. Have helper operate handle (17). Check that valve (15) opens and closes.

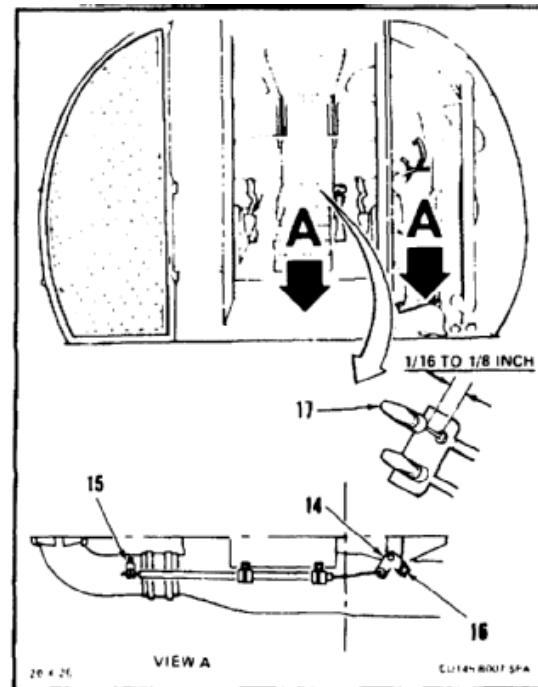
**INSPECT****FOLLOW-ON MAINTENANCE:**

- Install pilot's landing light (Task 9-79).
- Install floor access panel (Task 2-80).
- Install pilot's seat (Task 2-11).
- Install cockpit aft floor panel (Task 2-84).
- Install heater compartment acoustical blanket (Task 2-210).

END OF TASK

INITIAL SETUP

**Applicable Configurations:**

All

**Tools:**

Aircraft Mechanic's Tool Kit, NSN 5180-00-323-4692

**Materials:**

None

**Personnel Required:**

Medium Helicopter Repairer

**Equipment Condition:**

- Battery Disconnected (Task 1-39)
- Electrical Power Off
- Hydraulic Power Off
- Four Floor Panels at Sta. 120 Removed (Task 2-204)
- Heater Compartment Acoustical Blanket Removed (Task 2-208)
- Buffer Boards Removed (Task 2-217)
- Troop Seats Removed (Tasks 2-230 and 2-224)
- Winch Removed (Task 14-4)

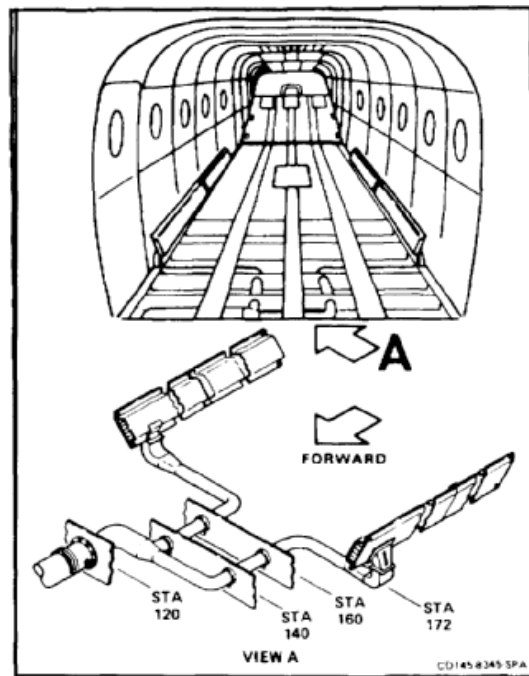

1. Loosen nut (1). Remove cable (2) from valve duct (3).
2. Loosen four clamps (4). Slide two hoses (5) to clear joints between valve duct and adjacent ducts.

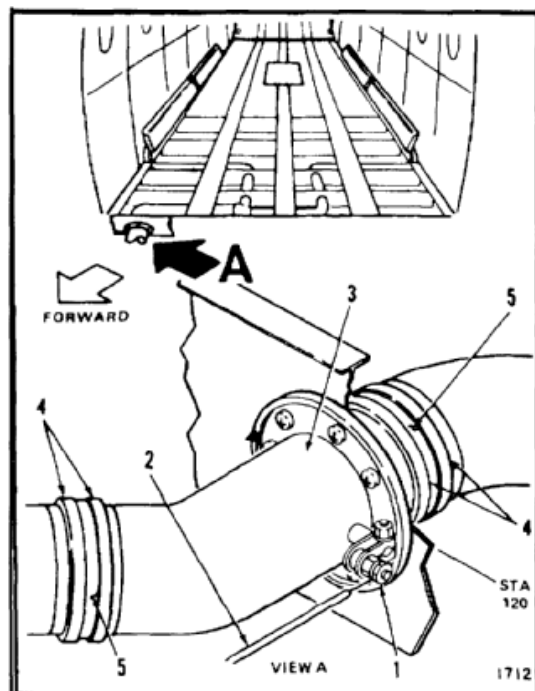

**NOTE**

Some valve ducts have nutplates and require removal of screws only.

3. Without nutplates, remove eight screws (6), washers (7), and nuts (8). Remove valve duct (3).
- 3.1. With nutplates, remove eight screws (6) and washers (7) from nutplates (8.1). Remove valve duct (3).
4. Remove two hoses (5) and four clamps (4).

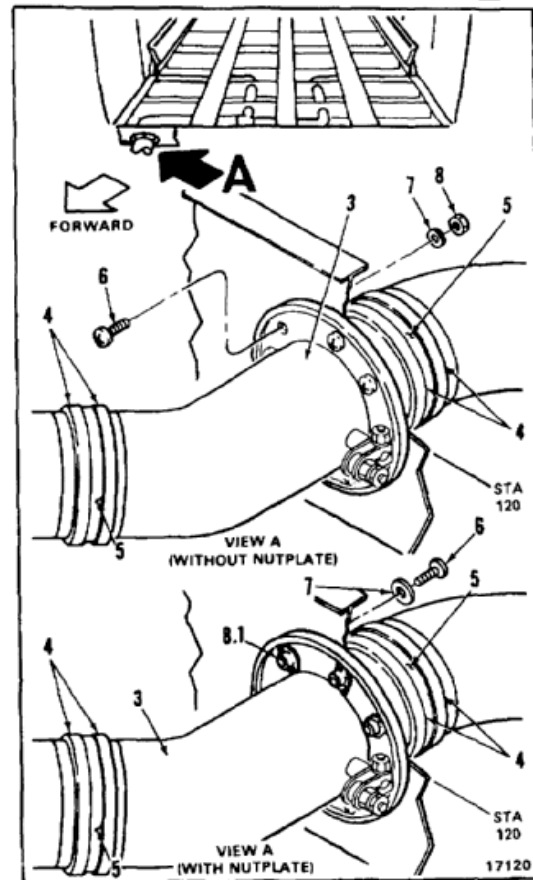

5. Remove two clamps (9). Disconnect two flex ducts (10) from manifold (11).
6. Remove two screws (12) and washers (13) from two support clamps (14).
7. Remove manifold (11). Remove two support clamps (14) from manifold.

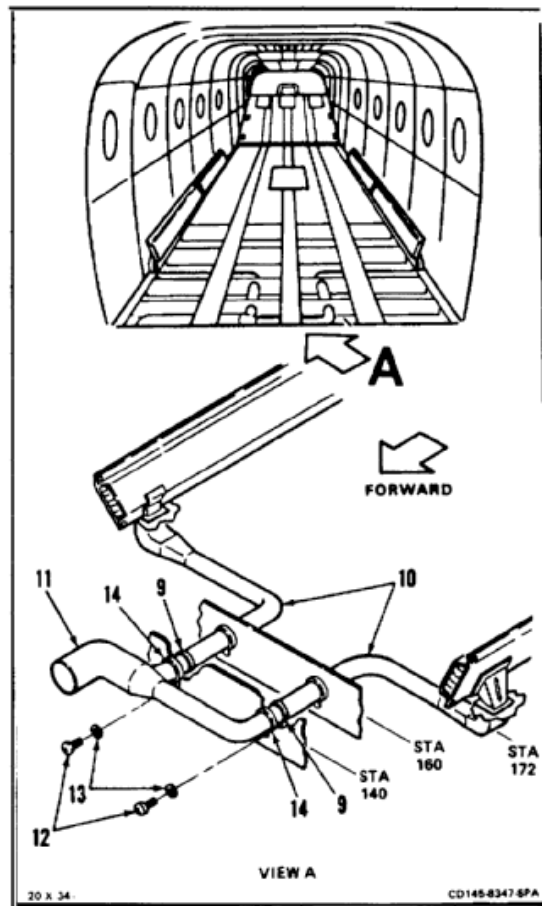

8. Remove 14 screws (15) and washers (16) from each flex duct (10).
9. Remove two screws (17) and washers (18) from two support clamps (19).
10. Remove two flex ducts (10). Remove two support clamps (19) from flex ducts.

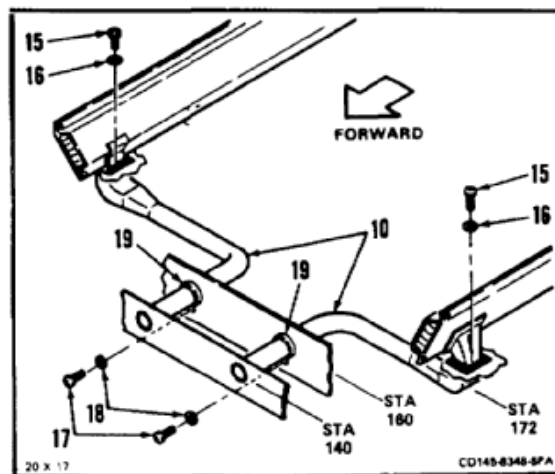

11. Remove nine screws (20), two washers (21), and two nuts (22) from each cover plate (23). Remove two cover plates.

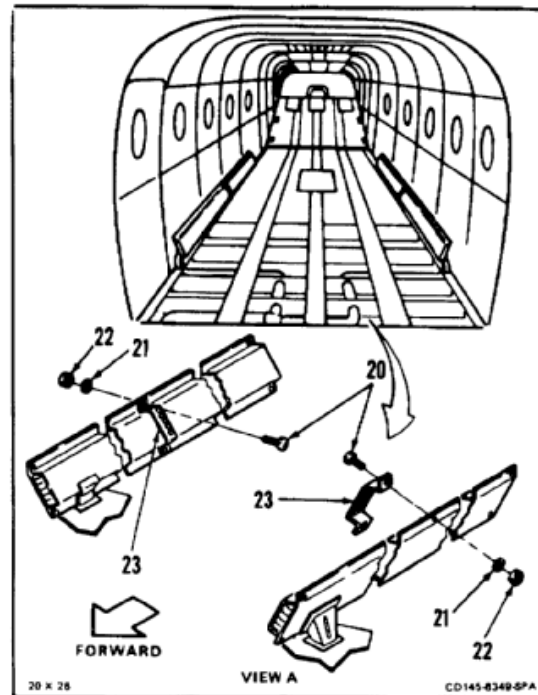

12. Remove eight screws (24), and washers (25), from each forward diffuser duct (26). Remove ducts.
13. Remove eight screws (27), and washers (28), from each aft diffuser duct (29). Remove ducts.

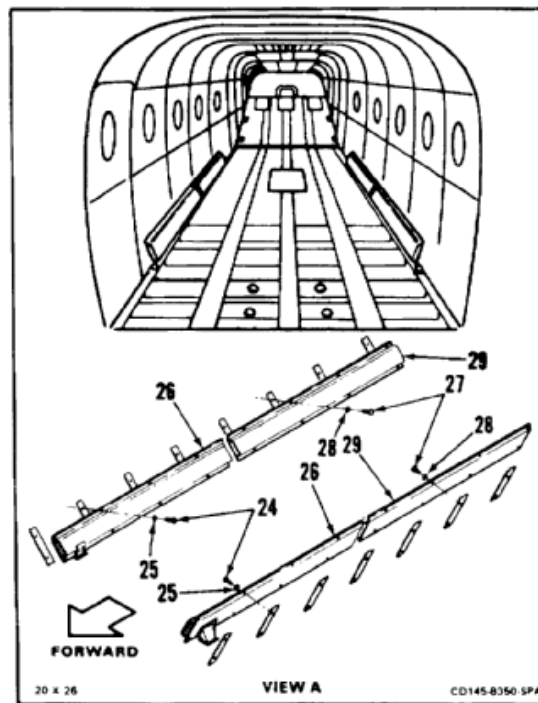

14. If damaged, remove transition diffuser duct (30) from each forward diffuser duct (26) as follows:
- Remove 16 screws (31) and washers (32).
  - Remove transition diffuser duct (30).
  - Remove two seals (33) and two seals (34).

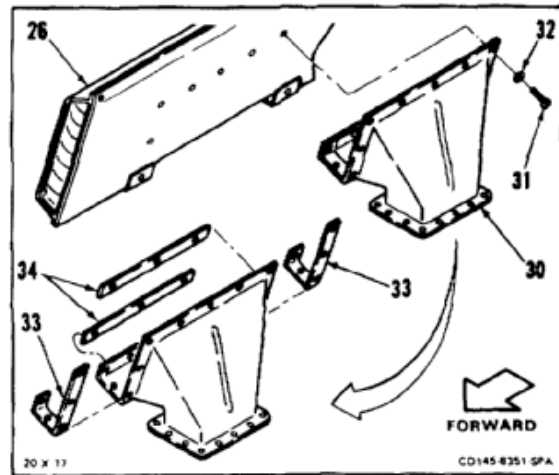
**FOLLOW-ON MAINTENANCE:**

None

END OF TASK

13-124



INITIAL SETUP

**Applicable Configurations:**

All

**Tools:**

Aircraft Mechanic's Tool Kit, NSN 51 80-00-323-4692

**Materials:**

Sealant (E340)  
Gloves (E186)

**Personnel Required:**

Medium Helicopter Repairer (2)

**References:**

TM 55-1520-240-23P

**General Safety Instructions:**

**WARNING**

Sealant (E340) can irritate skin and cause burns. Avoid contact with skin, eyes, or clothing. In case of contact, immediately flush skin or eyes with water for at least **15 minutes**. Get medical attention for eyes.

1. If transition diffuser duct (1) was removed, install it as follows:
  - a. Apply sealant (E340) to both sides of two seals (2) and two seals (3). Wear gloves (E186).
  - b. Position seals (2 and 3) on duct (1).
  - c. Align holes (4) in duct (1) and forward diffuser duct (5).
  - d. Install 16 screws (6) and washers (7).

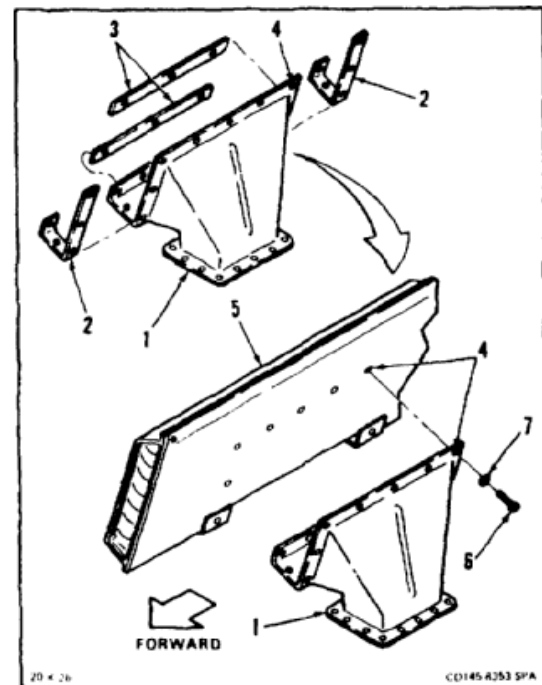
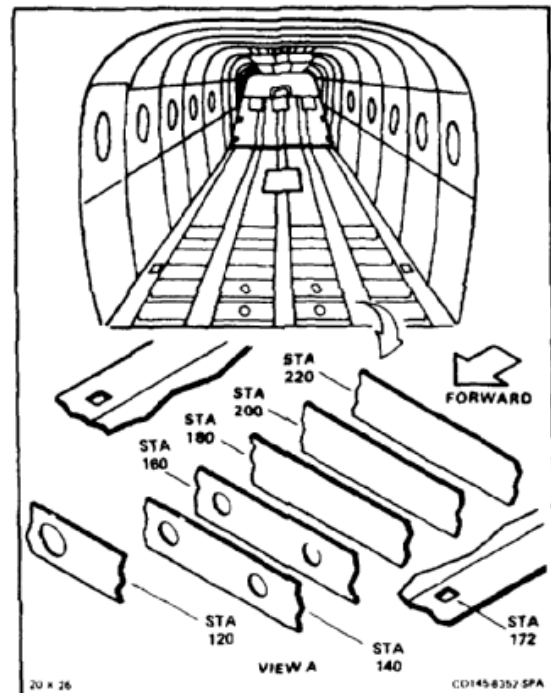

2. Position both aft diffuser ducts (9) on structure. Install eight screws (10), and washers (11), in each duct.

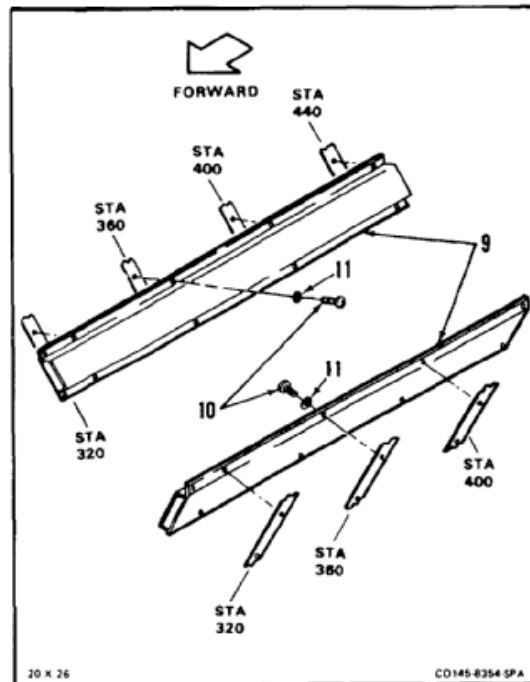

- 2.1. Install washer (11.1), spacer (11.2), and thumb screw (11.3) in duct assembly (11.4).

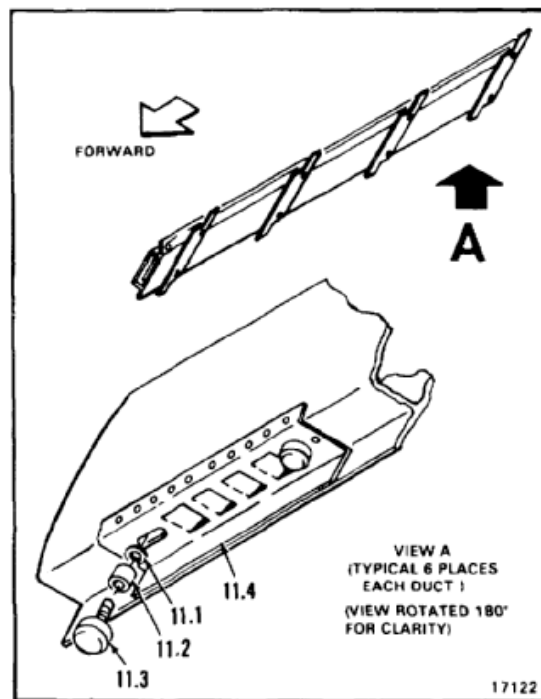

**13-39 INSTALL CABIN DUCTING (Continued)**

3. Apply sealant (E340) to flange of each transition diffuser duct (1). Wear gloves (E186).
4. Position both transition diffuser ducts (1) on structure. Install seven screws (12) and washers (13) in each duct. Install screw (14) and washers (15) in each duct.
5. Apply sealant (E340) to flange of each flexible duct (16). Wear gloves (E186).
6. Position flexible ducts (16) under cabin floor (17) and transition diffuser duct (1). Install 14 screws (18) and washers (19) in each duct (1).
7. Position two cover plates (20) over joints between forward and aft diffuser ducts (5 and 9). Install seven screws (21) and washers (22) in each plate. Install two screws (23), washers (24), and nuts (25) in each plate.

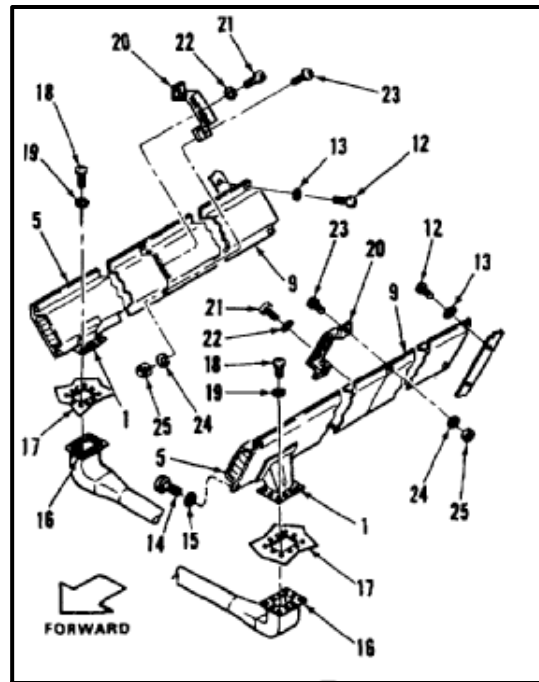

8. Route ducts (16) through holes in bulkhead at sta 160.
9. Position support clamps (26) on flexible ducts (16). Install screw (27) and washer (28) in each clamp (26).

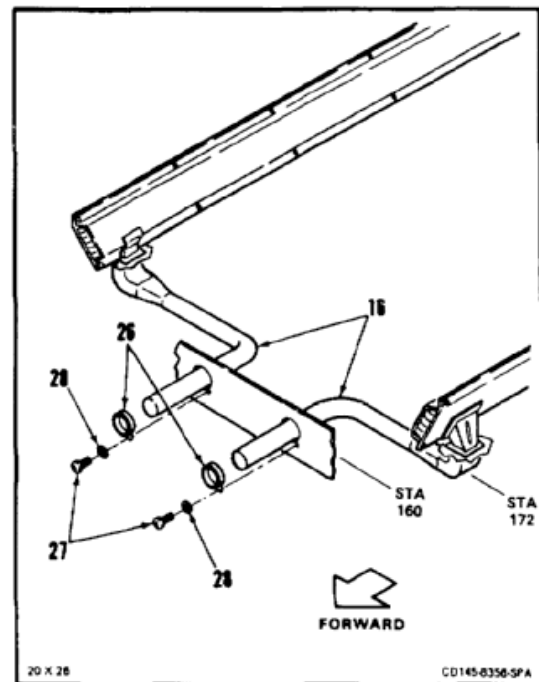

10. Position two support clamps (29) on manifold duct (30).
11. Slide hose (31) onto manifold duct (30).
12. Position manifold duct (30). Slide ends of flex ducts (16) on manifold duct (30). Install two clamps (32).
13. Install screw (33) and washer (34) in each support clamp (29).

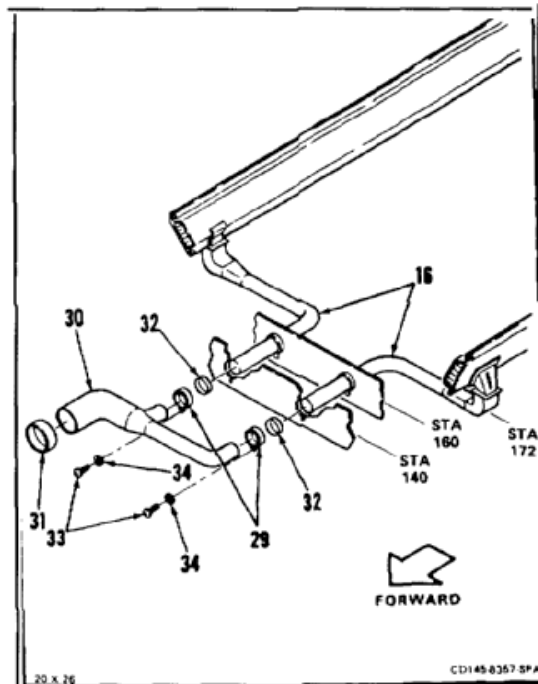

14. Slide hose (35) or valve duct (36).

**NOTE**

Some valve ducts have nutplates and require installation of screws only.

15. Without nutplates, position valve duct (36) between manifold duct (30) and transition duct (37). Install eight screws (38), washers (39), and nuts (40).

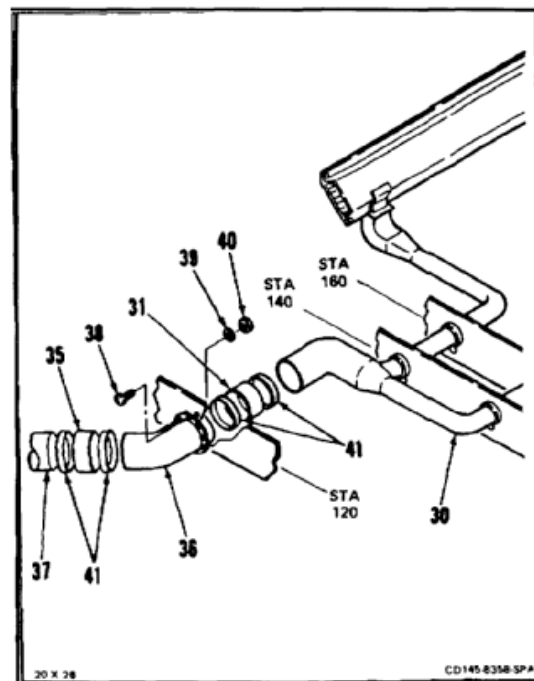

**13-39 INSTALL CABIN DUCTING (Continued)****13-39**

- 15.1. With nutplates, position valve duct (36) between manifold duct (30) and transition duct (37). Install eight screws (38) and washers (39) in nutplates (38.1).
16. Slide hoses (31 and 35) over joints between valve duct (36) and adjacent ducts (30 and 37).
17. Install four clamps (41).

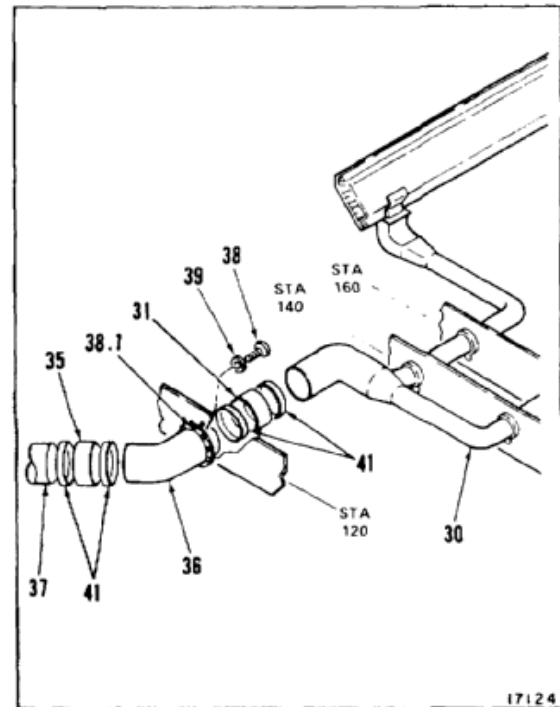

18. Install cabin heat control cable (42) into cable clamping nut (43) on valve duct (36).

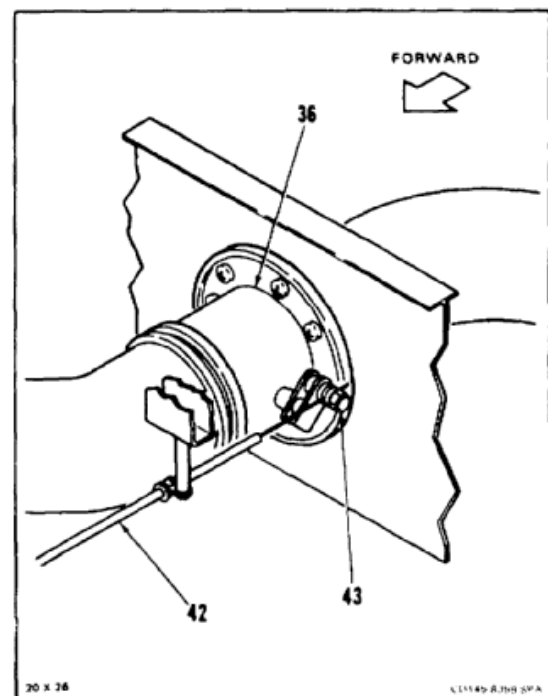

19. Have helper in cockpit hold cabin heat control handle (44) in a position  $1/16$  to  $1/8$  inch short of fully closed.
20. Hold heat valve (45) fully closed and tighten clamping nut (43).

**INSPECT**

21. Operate cabin heat control cable. Check for freedom of movement and full travel.

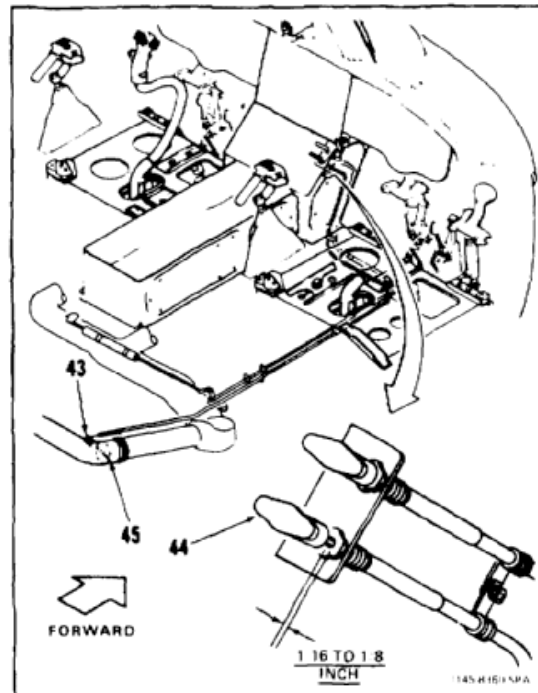
**FOLLOW-ON MAINTENANCE:**

- Install four floor panels at sta 120 (Task 2-207).
- Install winch (Task 14-9).
- Install heater compartment acoustical blanket (Task 2-210).
- Install buffer boards (Task 2-218).
- Install troop seats (Tasks 2-223 and 2-229).

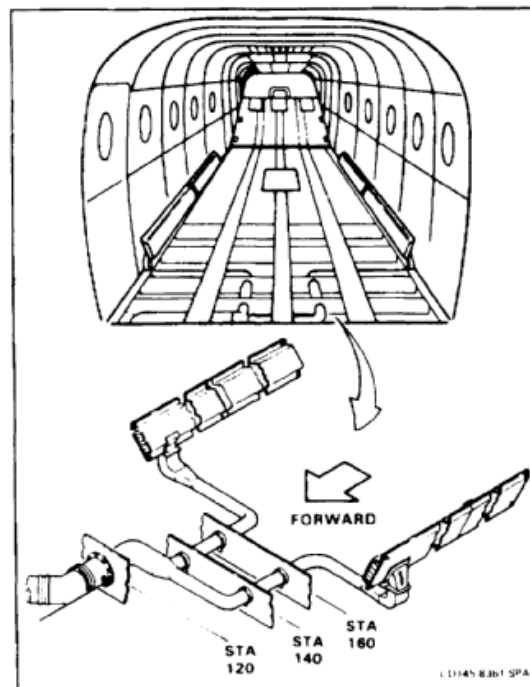

END OF TASK

INITIAL SETUP

**Applicable Configurations:**

All

**Tools:**

Aircraft Mechanic's Tool Kit, NSN 5180-00-323-4692  
 Airframe Repairer's Tool Kit, NSN 5180-00-323-4876

**Materials:**

None

**Personnel Required:**

Medium Helicopter Repairer  
 Aircraft Structural Repairer

**Equipment Conditions:**

Off Helicopter Task

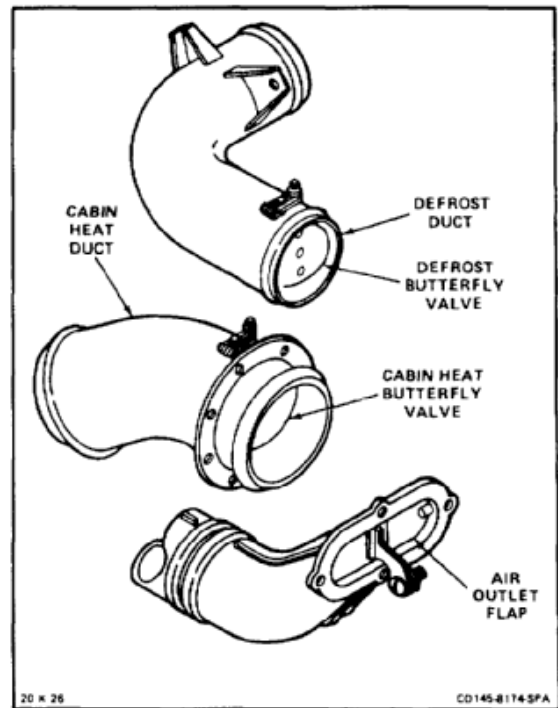

**REMOVE COCKPIT DEFROST OR CABIN HEAT BUTTERFLY VALVE**

**NOTE**

Procedure is same to remove cockpit defrost or cabin heat butterfly valve. Cockpit defrost valve is shown here.

1. Remove screw (1), washer (2), and nut (3) from lever (4).
2. Remove lever (4) and spacer (5) from shaft (6).

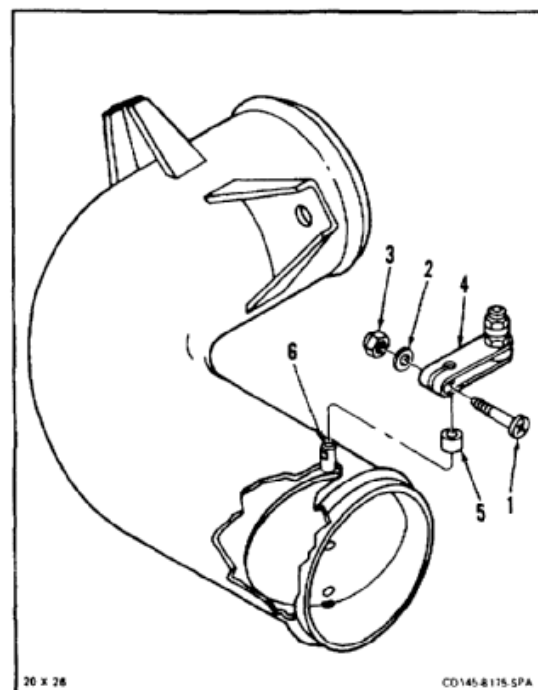

3. Remove three rivets (7) from butterfly valve (8) and shaft (6).
4. Remove butterfly valve (8), and shaft (6) from duct (9). Remove cotter pin (10) and washer (11) from shaft (6).

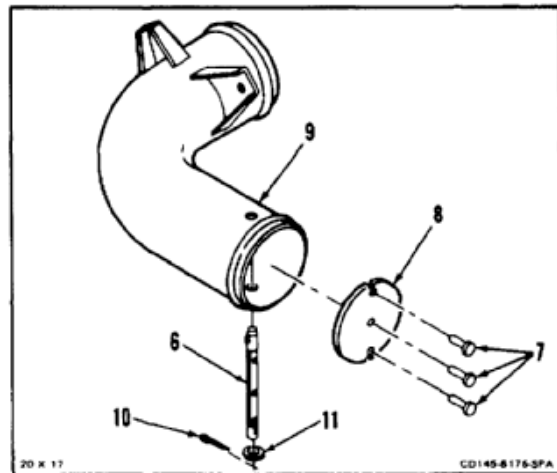

5. Remove cotter pin (12), washer (13), stud (14), and spacer (15) from lever (4).
6. Remove nut (16) and washer (17) from stud (14).

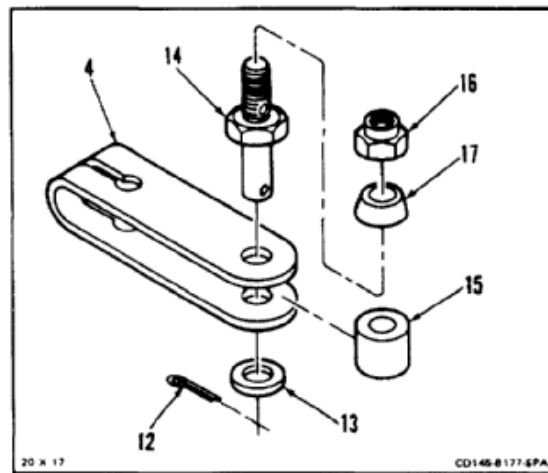

**REMOVE AIR OUTLET FLAP**

7. Remove lockwire and two screws (18).
8. Remove air outlet flap (19) from duct (20).
9. Remove nut (21), screw (22), and two collars (23) from arm (24).

**FOLLOW-ON MAINTENANCE:**

None

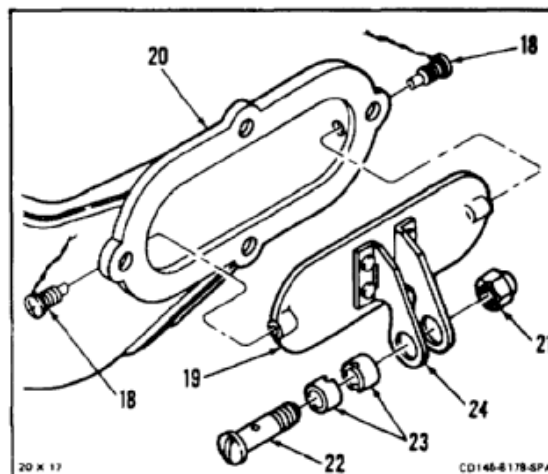

END OF TASK



INITIAL SETUP

**Applicable Configurations:**

All

**Tools:**

Aircraft Mechanic's Tool Kit, NSN 5180-00-323-4692  
 Airframe Repairer's Tool Kit, NSN 5180-00-323-4876

**Materials:**

Lockwire (E231)

**Parts:**

Rivets  
 Cotter Pins

**Personnel Required:**

Medium Helicopter Repairer  
 Aircraft Structural Repairer

**References:**

TM 55-1520-240-23P

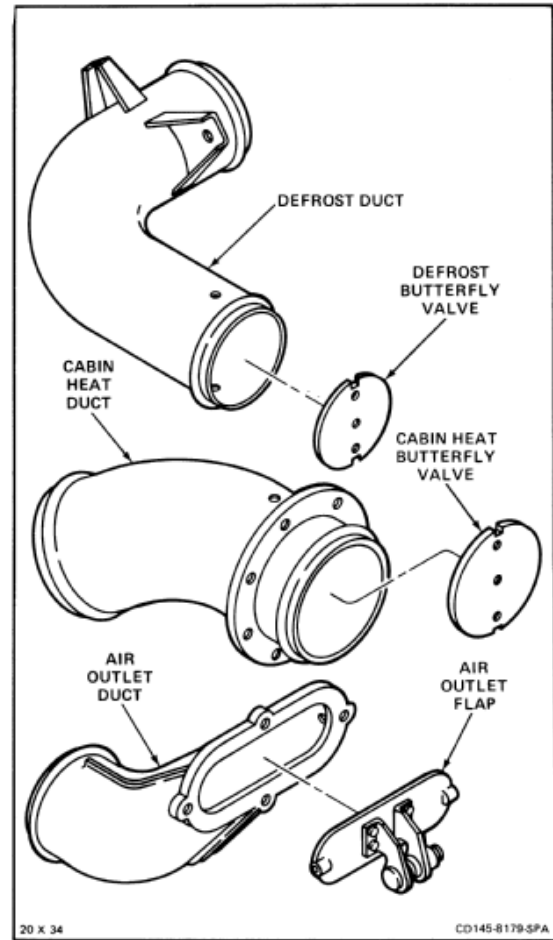

**INSTALL COCKPIT DEFROST OR CABIN HEAT BUTTERFLY VALVE**

**NOTE**

Procedures to install cockpit defrost or cabin heat butterfly valve is same. Cockpit defrost valve shown here.

1. Install washer (1) and nut (2) on stud (3).
2. Position spacer (4) in lever (5). Install stud (3).
3. Install washer (6) and cotter pin (7).

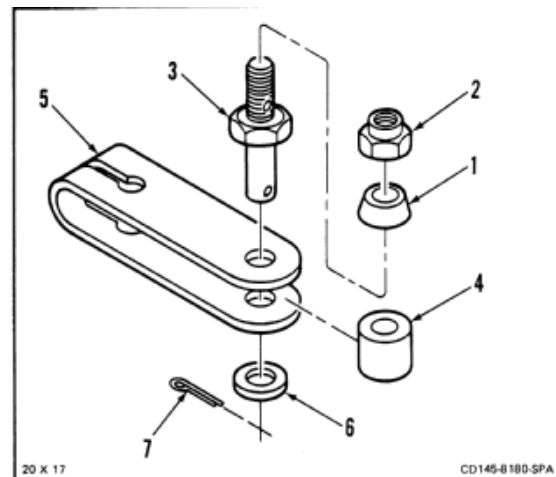

4. Position lever (5) on notched end of shaft (8). Install screw (9), washer (10), and nut (11).

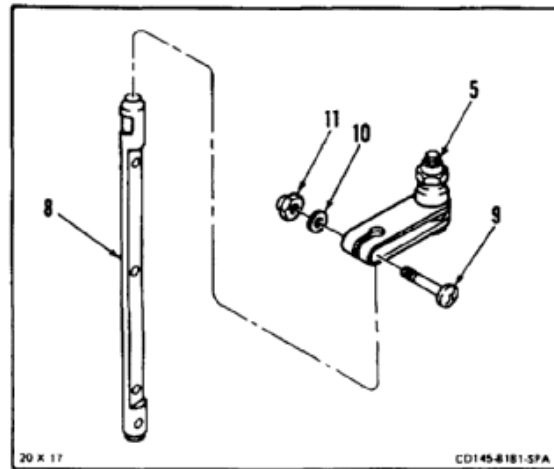

5. Slide shaft (8) through spacer (12) and defrost duct (13).
6. Install washer (14) and cotter pin (15).
7. Position butterfly valve (16) on shaft (8) so that notches in valve fit into shaft. Install three rivets (17).

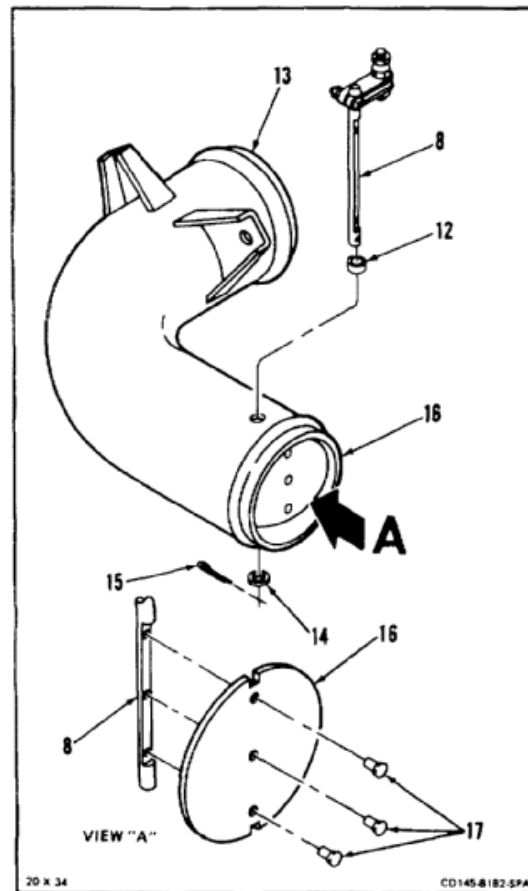

**INSTALL AIR OUTLET FLAP**

8. Position air outlet flap (18) in air outlet duct (19). Install two screws (20).
9. Lockwire screws (20). Use lockwire (E231).
10. Install screw (21), two collars (22), and nut (23) in arm (24).

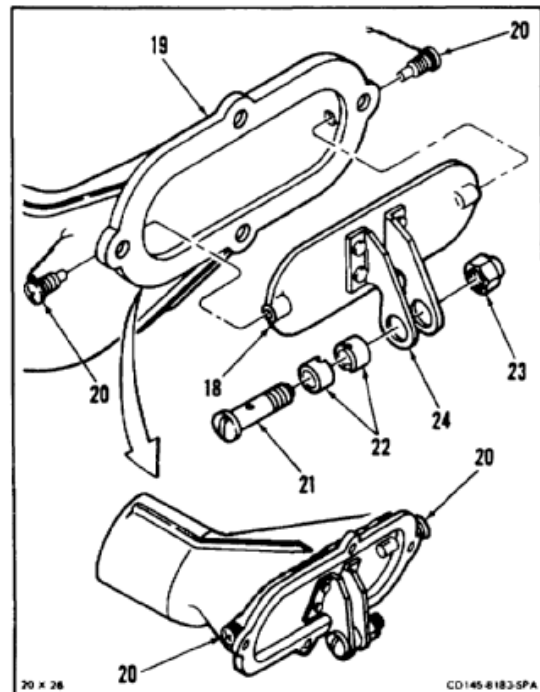
**FOLLOW-ON MAINTENANCE:**

None

END OF TASK

INITIAL SETUP

**Applicable Configurations:**

All

**Tools:**

Aircraft Mechanic's Tool Kit, NSN 5180-00-323-4692

**Materials:**

None

**Personnel Required:**

Medium Helicopter Repairer

**Equipment Condition:**

- Battery Disconnected (Task 1-39)
- Electrical Power Off
- Hydraulic Power Off

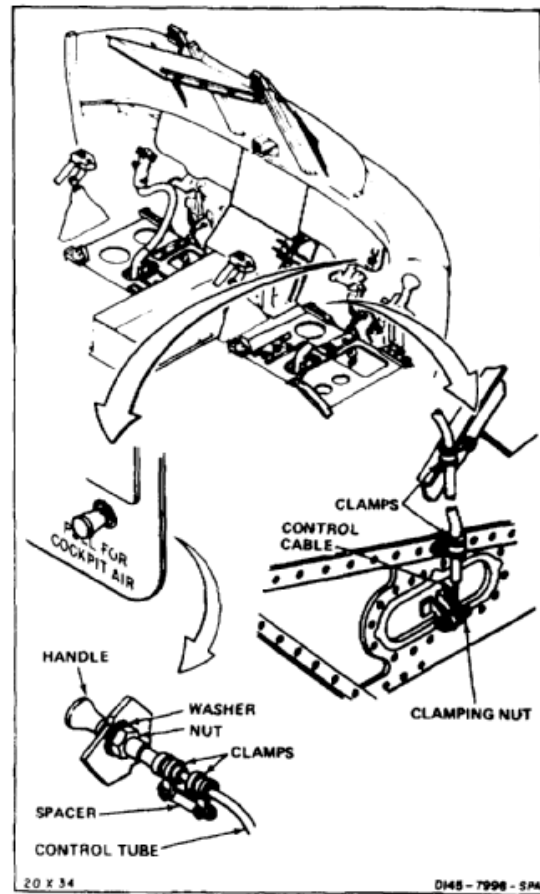

**NOTE**

Procedure is same to remove pilot's or copilot's cockpit air control. Pilot's air control shown here.

**REMOVE COCKPIT AIR CONTROL CABLE**

1. Loosen cable clamping nut (1) on cockpit air outlet flap (2). Disconnect control cable (3).
2. Pull handle (4) to remove control cable (3).

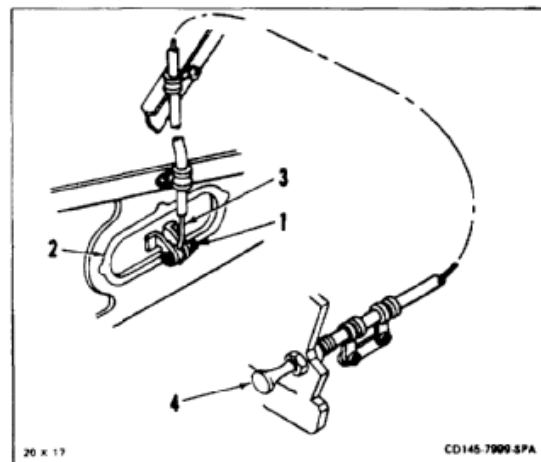

**REMOVE COCKPIT AIR CONTROL TUBE**

3. Loosen two clamps (5).
4. Loosen two clamps (6).
5. Remove nut (7) and washer (8) from control (9).  
Remove control from instrument panel (10).
6. Remove two clamps (6) with spacer (11).
7. Remove tube (12).

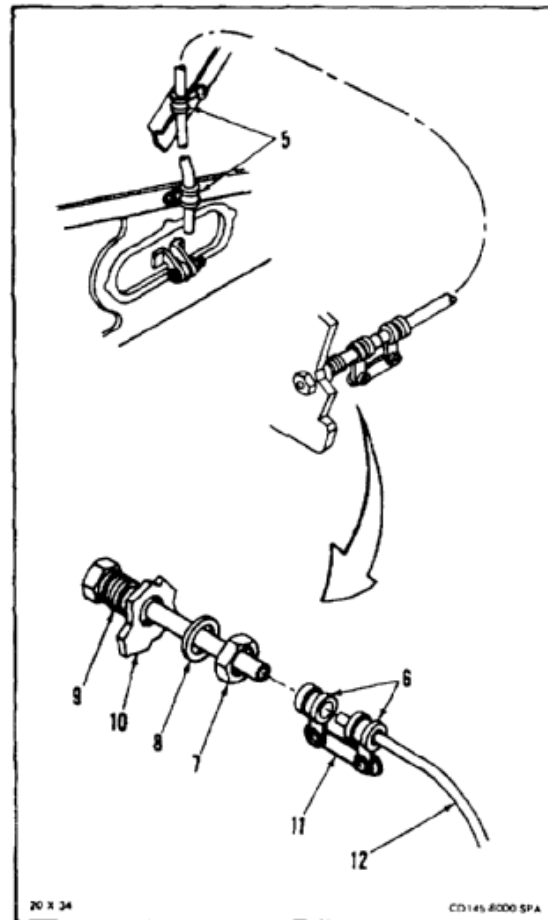
**FOLLOW-ON MAINTENANCE:**

None

END OF TASK

INITIAL SETUP

**Applicable Configurations:**

All

**Tools:**

Aircraft Mechanic's Tool Kit, NSN 5180-00-323-4692

**Materials:**

None

**Personnel Required:**

Medium Helicopter Mechanic (2)  
Inspector

**References:**

TM 55-1520-240-23P

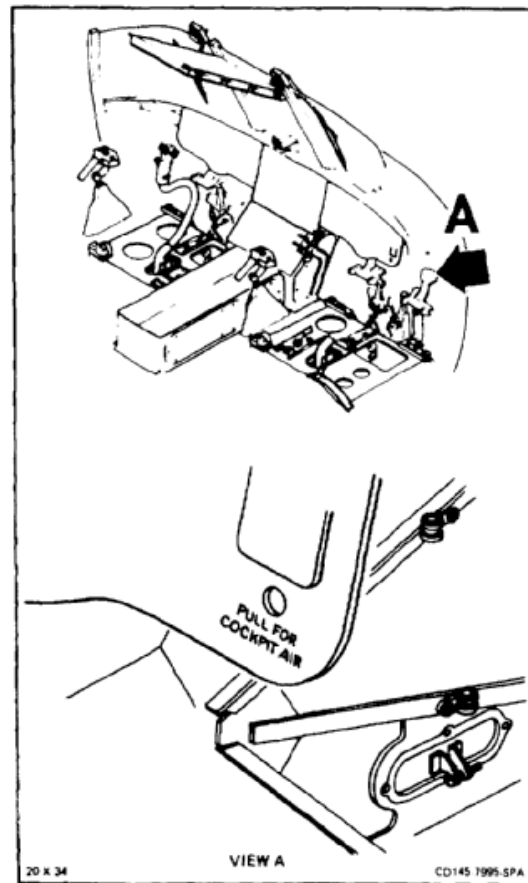

**NOTE**

Procedure to install pilot's or copilot's cockpit air control is same. Pilot's air control shown here.

**INSTALL COCKPIT AIR CONTROL TUBE**

1. Route control tube (1) through three clamps (2).
2. Position clamps (3 and 4) with spacer (5) on control tube (1).
3. Position control (6) in instrument panel (7). Install washer (8) and nut (9).

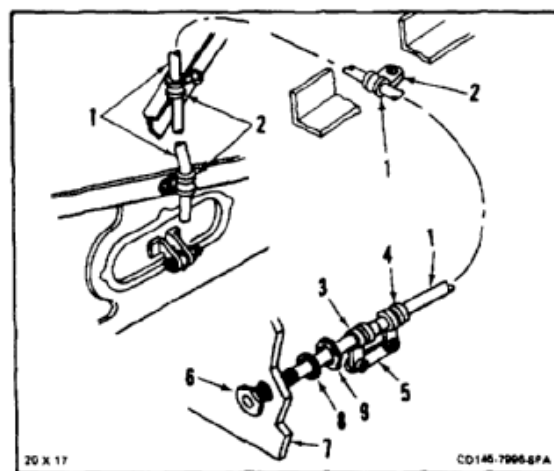

**13-43 INSTALL COCKPIT AIR CONTROL (Continued)**

13-43

4. Insert tube (1) **1 inch** into control (6).
5. Position clamps (3 and 4) with spacer (5) on tube (1) and control (6). Tighten clamps.
6. Tighten three clamps (2).

**INSTALL COCKPIT AIR CONTROL CABLE**

7. Thread control cable (10) through tube (1) into cable clamping nut (11).
8. Have helper hold control handle (12) in a position **1/16 to 1/8 inch** short of fully closed.
9. Hold air outlet flap (13) fully closed. Tighten cable clamping nut (11).
10. Have helper operate handle (12). Check that flap (13) opens and closes.

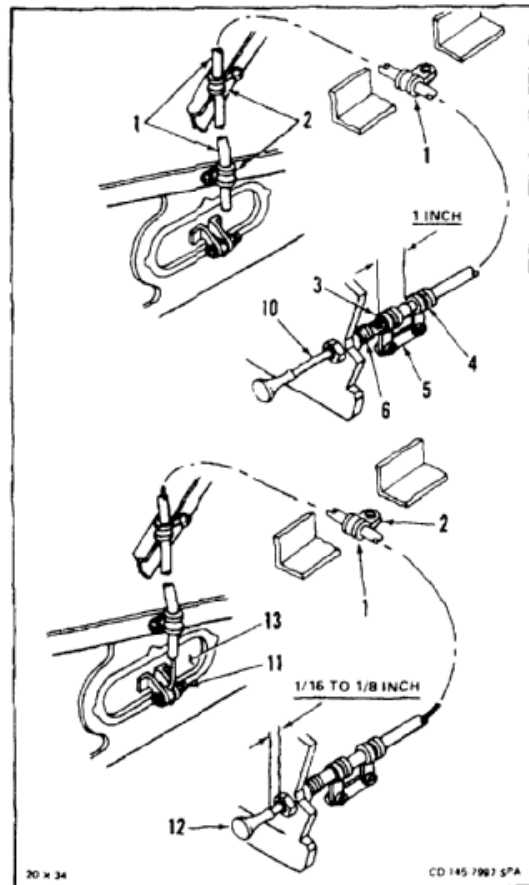
**INSPECT****FOLLOW-ON MAINTENANCE:**

None

END OF TASK

INITIAL SETUP

**Applicable Configurations:**

All

**Tools:**

Aircraft Mechanic's Tool Kit, NSN 5180-00-323-4692

**Materials:**

None

**Personnel Required:**

Medium Helicopter Repairer

**Equipment Condition:**

- Battery Disconnected (Task 1-39)
- Electrical Power Off
- Hydraulic Power Off
- Pilot's Seat Removed (Task 2-111)
- Pilot's Floor Access Panel Removed (Task 2-79)
- Heater Compartment Acoustical Blanket Removed (Task 2-208)
- Pilot's Landing Light Removed (Task 9-69)
- Winch Removed (Task 14-4)

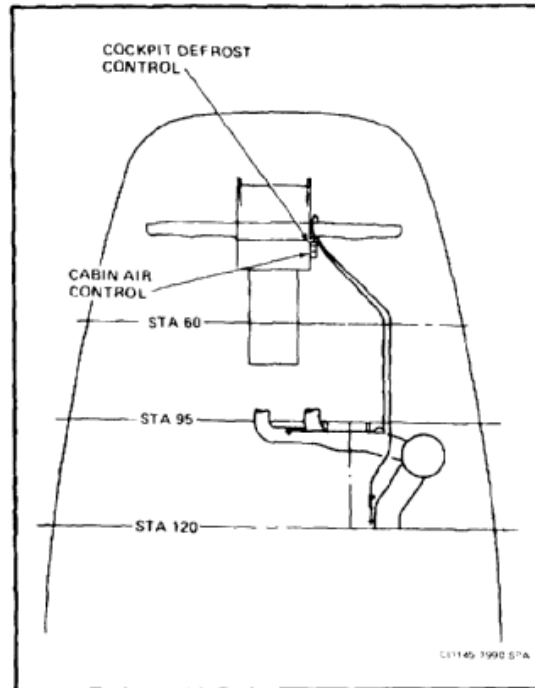

1. Loosen cable clamping nut (1).
2. Loosen clamp (2).

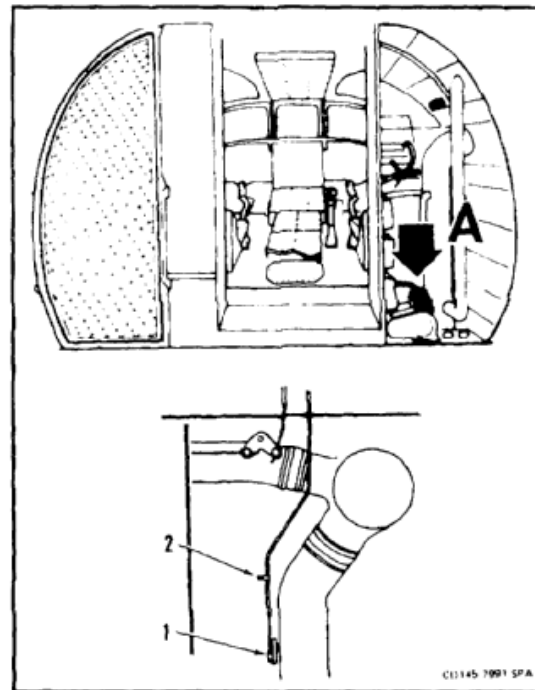



**REMOVE CABIN AIR CONTROL CABLE**

3. Pull cabin air control handle (3) and remove cable (4).
4. Remove nut (5) and washer (6) from control (7).
5. Remove control (7) from mounting plate (8).
6. Loosen three clamps (9).

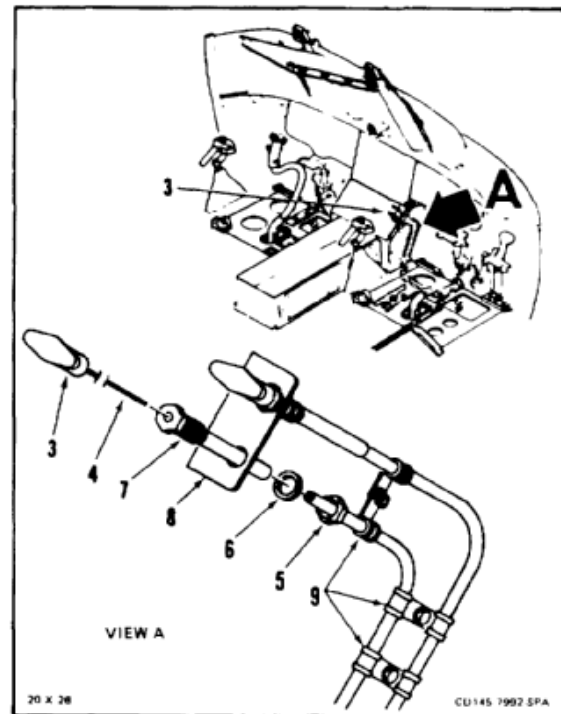
**REMOVE AIR CONTROL TUBE**

7. Loosen clamp (10) on air control tube (11).

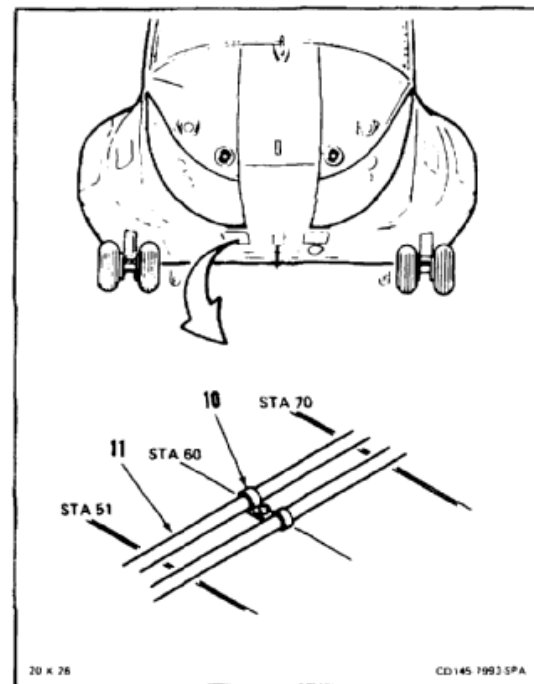

8. Loosen clamp (12).
9. Remove tube (11).

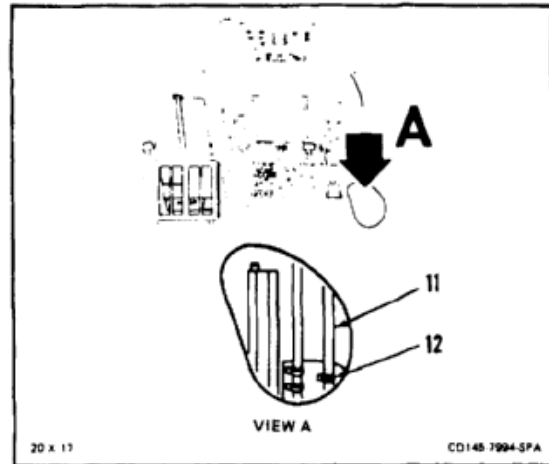
**FOLLOW-ON MAINTENANCE:**

None

END OF TASK

13-142

## INITIAL SETUP

**Applicable Configurations:**

All

**Tools:**

Aircraft Mechanic's Tool Kit, NSN 5180-00-323-4692

**Materials:**

None

**Personnel Required:**

Medium Helicopter Repairer (2)

**References:**

TM 55-1520-240-23P

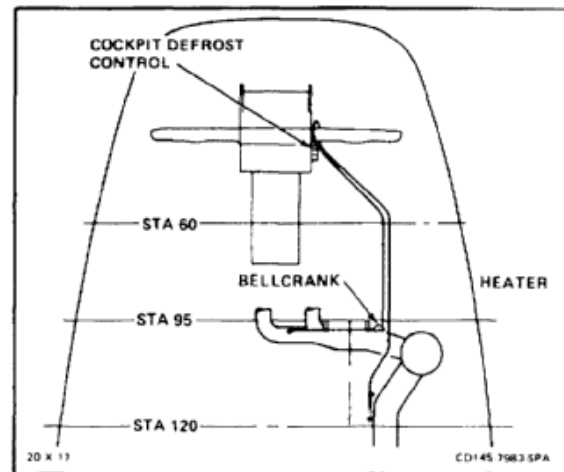
**INSTALL CABIN AIR CONTROL TUBE**

1. Position control (1) in mounting plate (2). Install washer (3) and nut (4).
2. Route control tube (5) through three clamps (6).
3. Insert end of tube (5) **1 inch** into control (1).
4. Tighten three clamps (6).

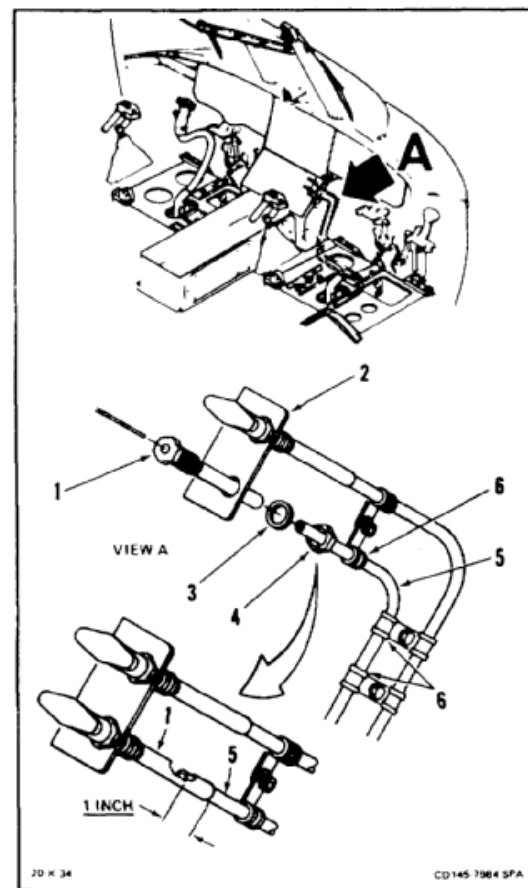

5. Route tube (5) through clamp (7). Tighten clamp.

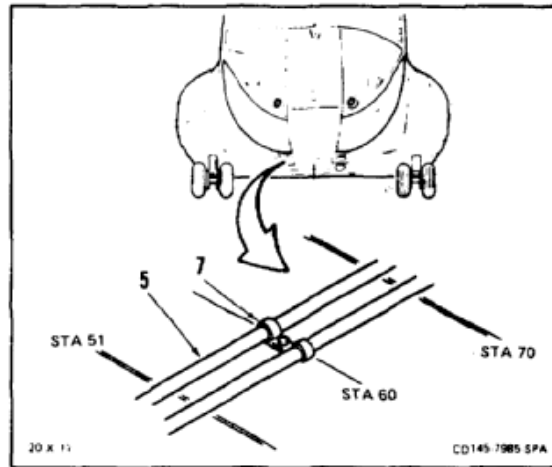

6. Route tube (5) through clamp (8). Tighten clamp.

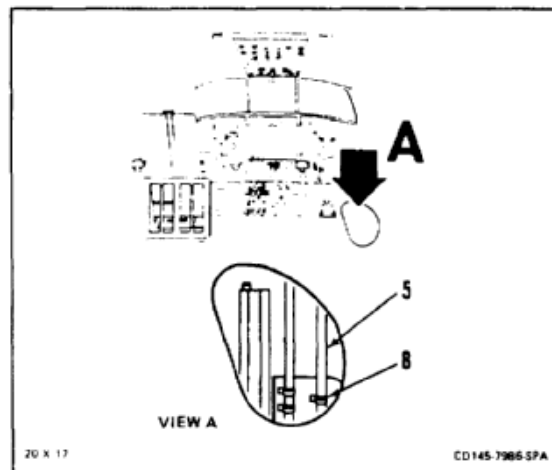

7. Route tube (5) through clamp (9). Tighten clamp.

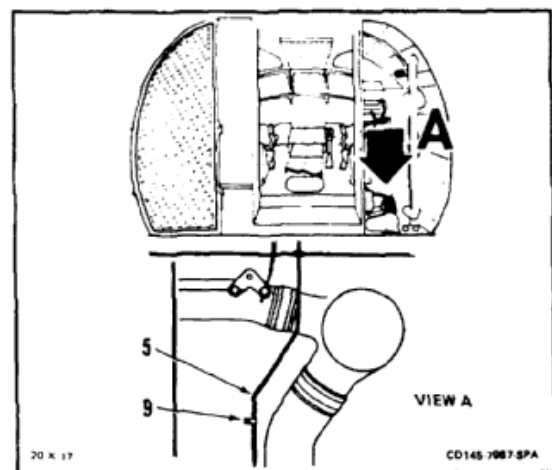

**INSTALL CABIN AIR CONTROL CABLE**

8. Thread cable (10) through tube (5).

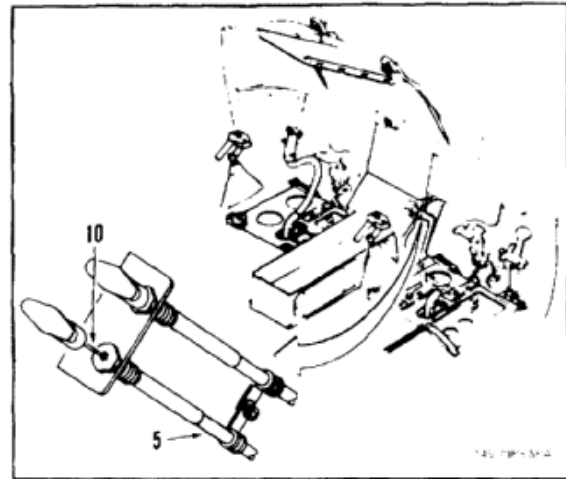

9. Insert cable (10) into cable clamping nut (11).
10. Have helper in cockpit position cabin air control handle (12) **1/16 to 1/8 inch** short of fully closed.
11. Hold air valve (13) fully closed. Tighten nut (11).
12. Have helper operate handle (12). Check that valve (13) opens and closes.

**FOLLOW-ON MAINTENANCE:**

- Install pilot's landing light (Task 9-79).
- Install pilot's floor access panel (Task 2-80).
- Install pilot's seat (Task 2-114).
- Install winch (Task 14-9).
- Install heater compartment acoustical blanket (Task 2-210).

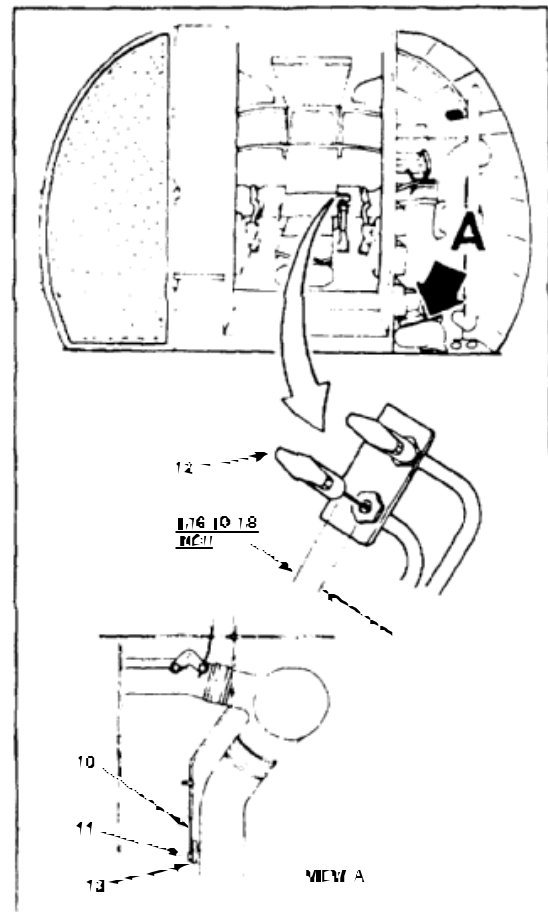

END OF TASK

INITIAL SETUP

**Applicable Configurations:**

All

**Tools:**

Electrical Repairer's Tool Kit, NSN 5180-00-323-4915

**Materials:**

Paper Tags (E264)  
Tape (E395)

**Personnel Required:**

Aircraft Electrician

**Equipment Condition:**

Battery Disconnected (Task 1-39)

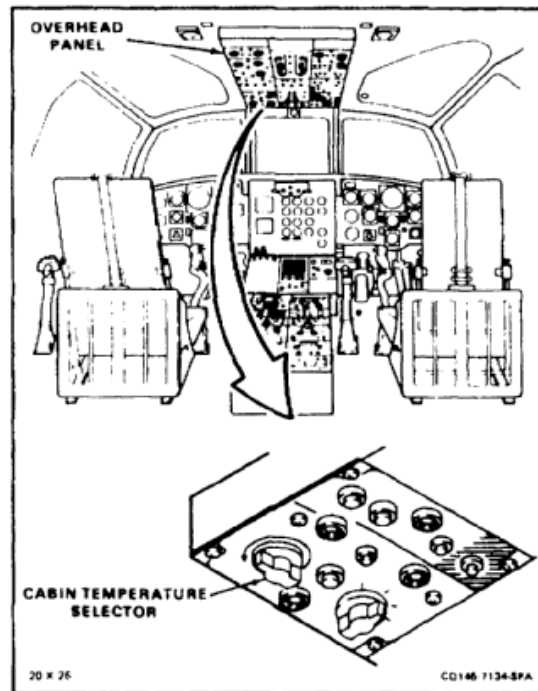

1. Loosen two setscrews (1). Remove two knobs (2) from plastic panel (3).
2. Turn four panel lights (4) counterclockwise. Remove lights and seals (5) from plastic panel (3).
3. Turn two press-to-test lights (6) counterclockwise. Remove press-to-test lights from plastic panel (3). Tag lights.

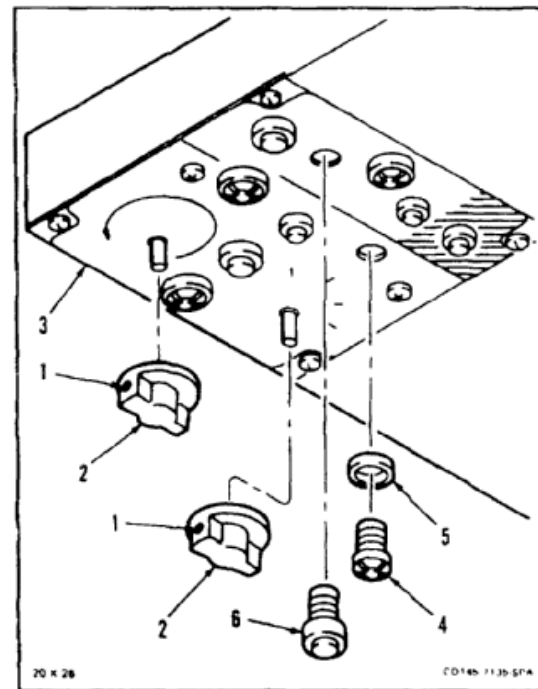

**13-46 REMOVE CABIN TEMPERATURE SELECTOR (Continued)**

13-46

4. Remove two screws (7) and plastic panel (3) from metal panel (8).
5. Release four screws (9). Remove metal panel (8) from cockpit overhead panel (10).

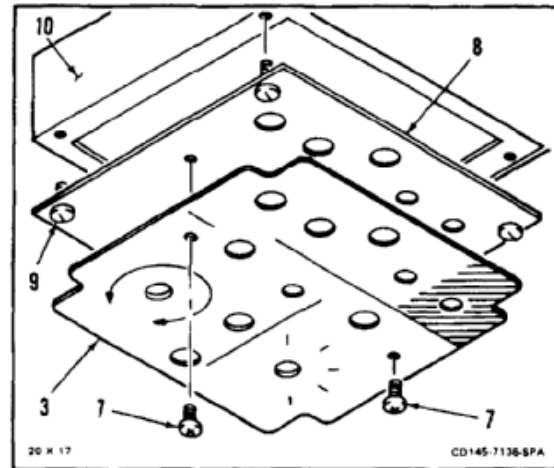

6. Tag two wires (11). Remove two screws (12), washers (13), and wires (11) from cabin temperature selector (14).
7. Remove locknut (15) and selector (14) from metal panel (8).
8. Tape exposed ends of wires (11). Use tape (E395).

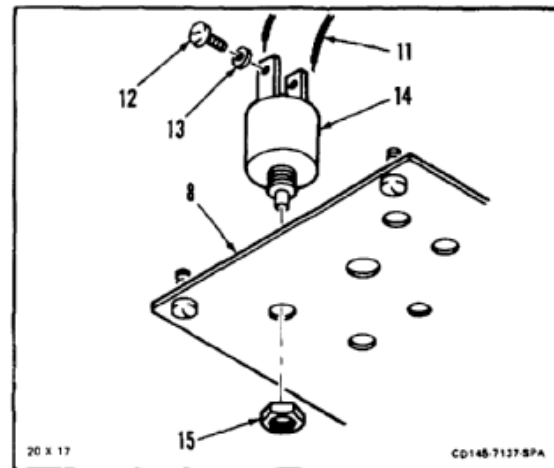
**FOLLOW-ON MAINTENANCE:**

None

END OF TASK

INITIAL SETUP

**Applicable Configurations:**

All

**Tools:**

Electrical Repairer's Tool Kit, NSN 5180-00-323-4915

**Materials:**

None

**Personnel Required:**

Aircraft Electrician  
Inspector

**References:**

TM 55-1520-240-23P

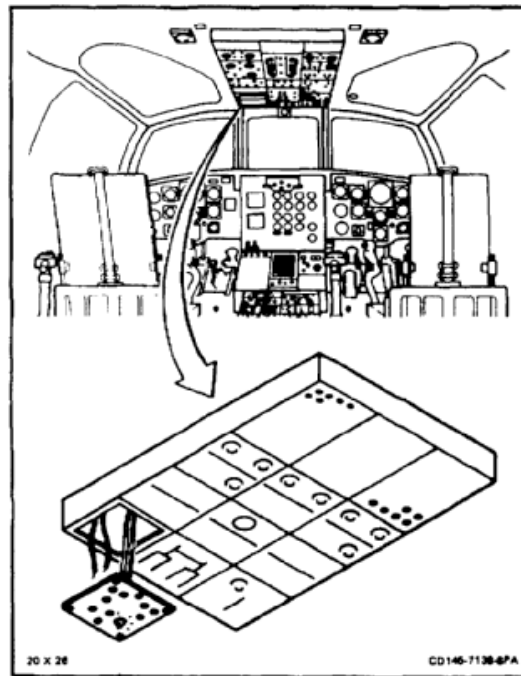

1. Position cabin temperature selector (1) in metal panel (2). Install locknut (3) on selector.
2. Remove tape from two electrical wires (4).
3. Connect two wires (4) to selector (1). Install two screws (5) and washers (6). Remove tags.

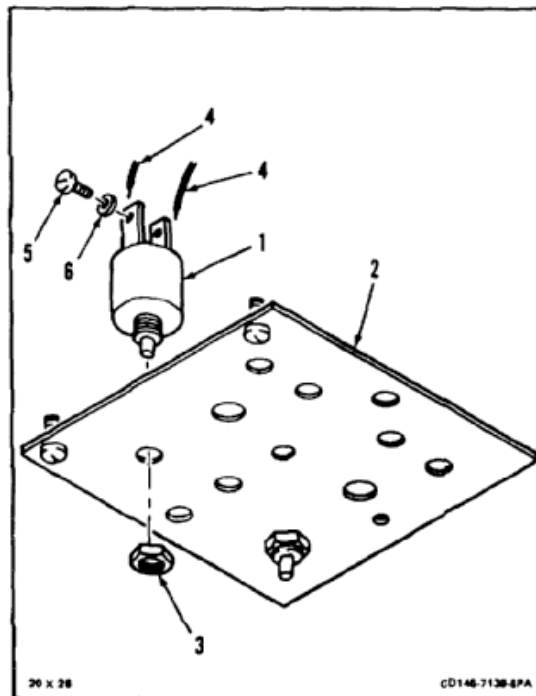



**13-47 INSTALL CABIN TEMPERATURE SELECTOR (Continued)**

13-47

4. Position metal panel (2) in cockpit overhead panel (7). Tighten four fasteners (8).
5. Align holes in plastic panel (9) and metal panel (2). Install two screws (10).

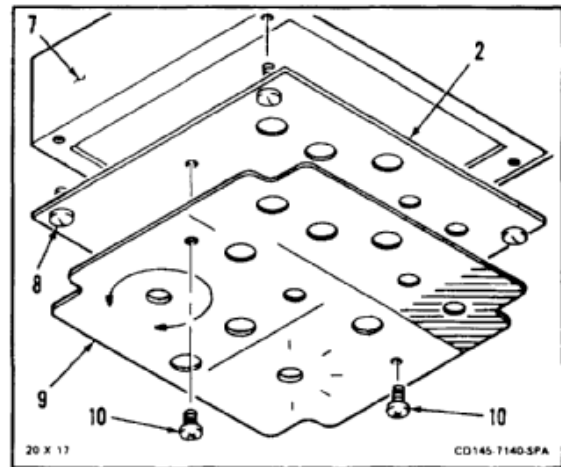

6. Install four panel lights (11) and seals (12) in plastic panel (9).
7. Remove tags and install two press-to-test lights (13) in plastic panel (9).
8. Install two knobs (14) on selectors (1 and 15).
9. Tighten setscrews (16).

**FOLLOW-ON MAINTENANCE:**

Perform operational check of heating system (TM 55-1520-240-T).

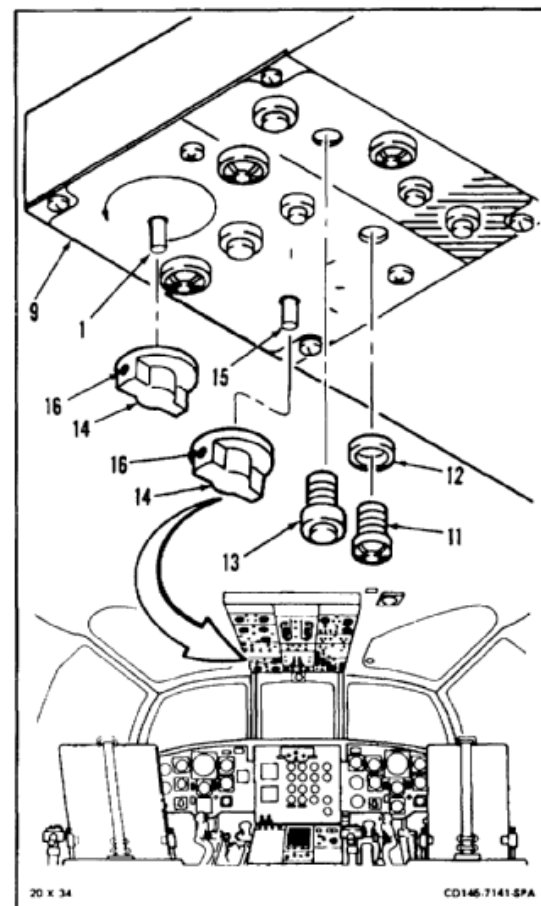

END OF TASK

## INITIAL SETUP

**Applicable Configurations:**

All

**Tools:**

Aircraft Mechanic's Tool Kit, NSN 5180-00-323-4692  
Grounded Container, Two Quart

**Materials:**

Cloths (E135)  
As Required

**Personnel Required:**

Medium Helicopter Repairer

**Equipment Conditions:**

Battery Disconnected (Task 1-39)  
Electrical Power Off  
Helicopter Grounded (Task 1-29)  
Right Aft Intertank Access Door Opened (Task 2-2)

**General Safety Instructions:****WARNING**

All regulations and instructions for handling fuels shall be strictly observed.

1. Remove lockwire and disconnect electrical connector (1).
2. Disconnect two fuel hoses (2). Use container and cloths (E135) for spilled fuel. Plug hoses.
3. Remove two bolts (3) and washers (4). Remove valve (5).

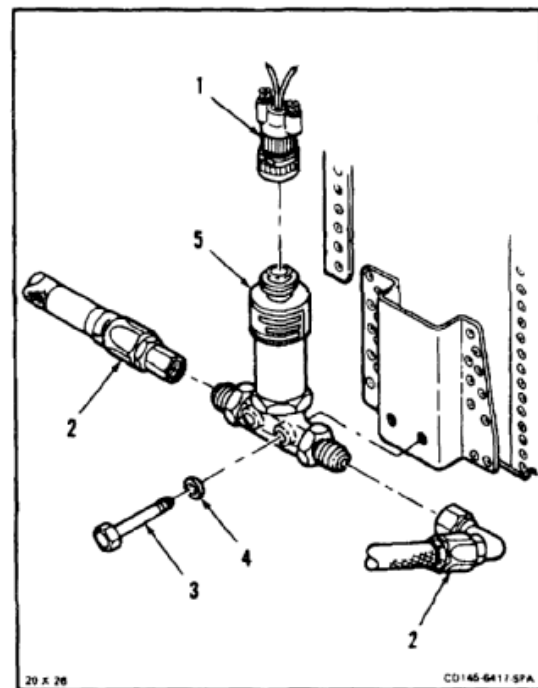
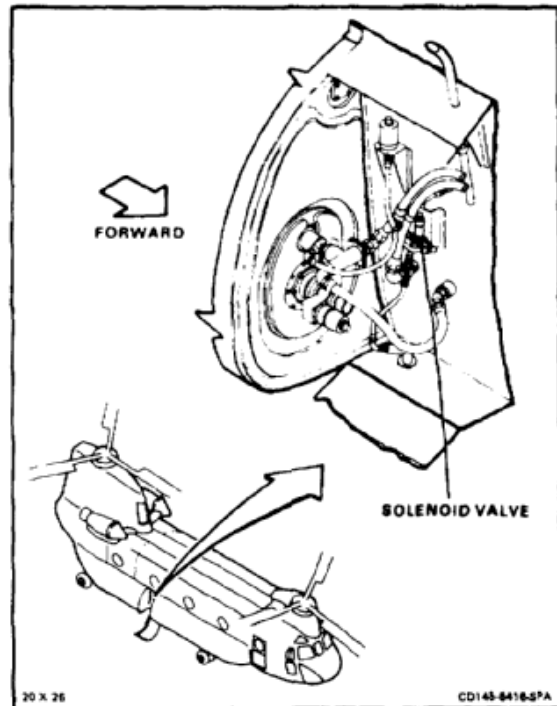

**13-48 REMOVE HEATER FUEL SOLENOID VALVE (Continued)****13-48**

4. Remove, two reducers (6) and packings (7) from valve (5).
5. Remove strainer (8).

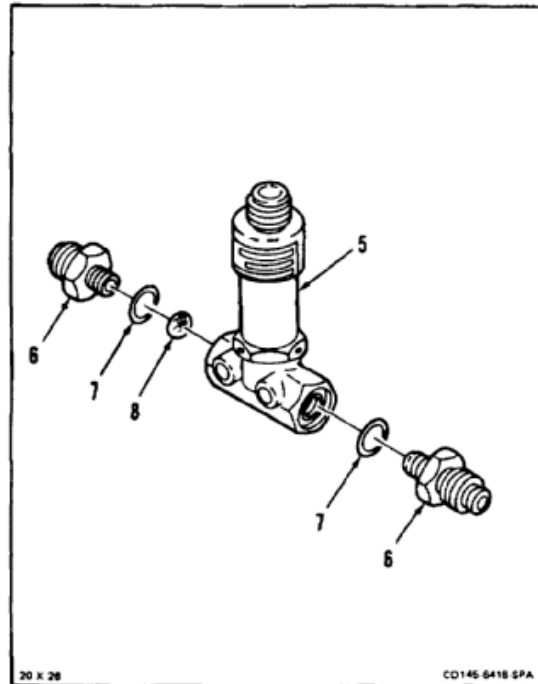
***FOLLOW-ON MAINTENANCE:***

None

END OF TASK

INITIAL SETUP

**Applicable Configurations:**

All

**Tools:**

Aircraft Mechanic's Tool Kit, NSN 5180-00-323-4692

**Materials:**

Lockwire (E231)

**Parts:**

Packing

**Personnel Required:**

Medium Helicopter Repairer  
Inspector

**References:**

TM 55-1520-240-23P

**General Safety Instructions:**

**WARNING**

All regulations and instructions for handling fuels shall be strictly observed.

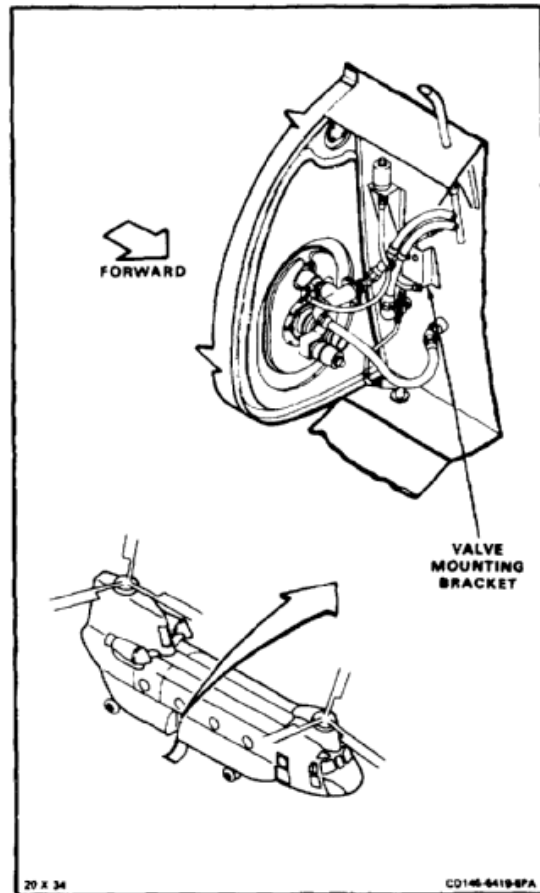

1. Install strainer (1) in end of valve (2) opposite arrow (3).
2. Install two reducers (4) and packings (5).

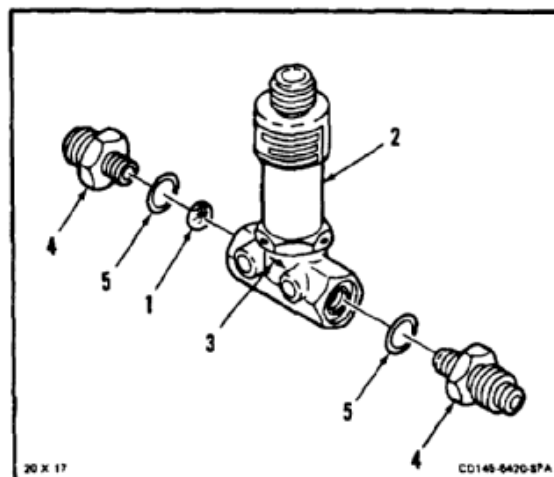

3. Position valve (2) on bracket (6), arrow (3) forward.
4. Install two bolts (7) and washers (8).
5. Remove plugs and connect two fuel hoses (9).
6. Connect electrical connector (10) to valve (2).

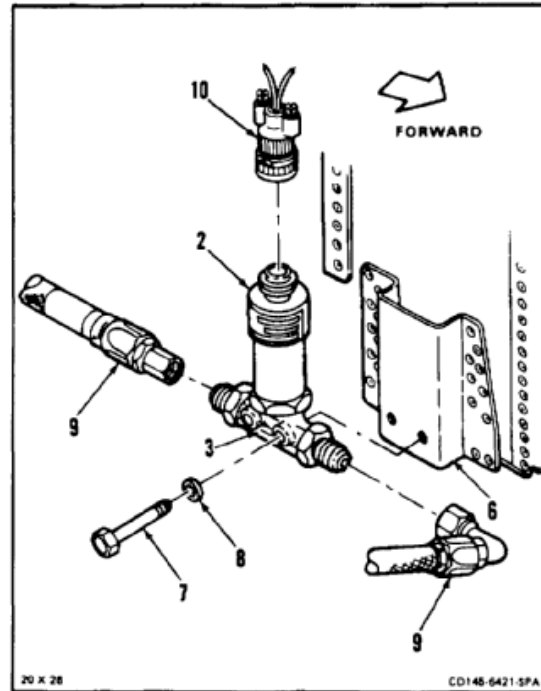

7. Lockwire (E231) connector (10) to valve (2).

**INSPECT**

**FOLLOW-ON MAINTENANCE:**

Close right aft intertank access door (Task 2-2).  
 Perform operational check (TM 55-1520-240-T).

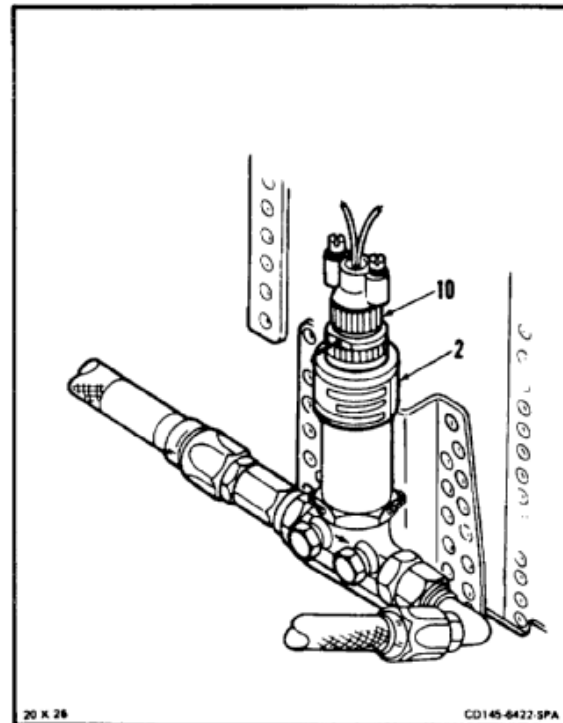

END OF TASK

INITIAL SETUP

**Applicable Configurations:**

All

**Tools:**

Aircraft Mechanic's Tool Kit, NSN 5180-00-323-4692

**Materials:**

Paper Tags (E264)  
Electrical Tape (E385)

**Personnel Required:**

Medium Helicopter Repairer

**Equipment Condition:**

Battery Disconnected (Task 1-39)  
Electrical Power Off  
Heater Compartment Acoustic Blanket Removed (Task 2-208)

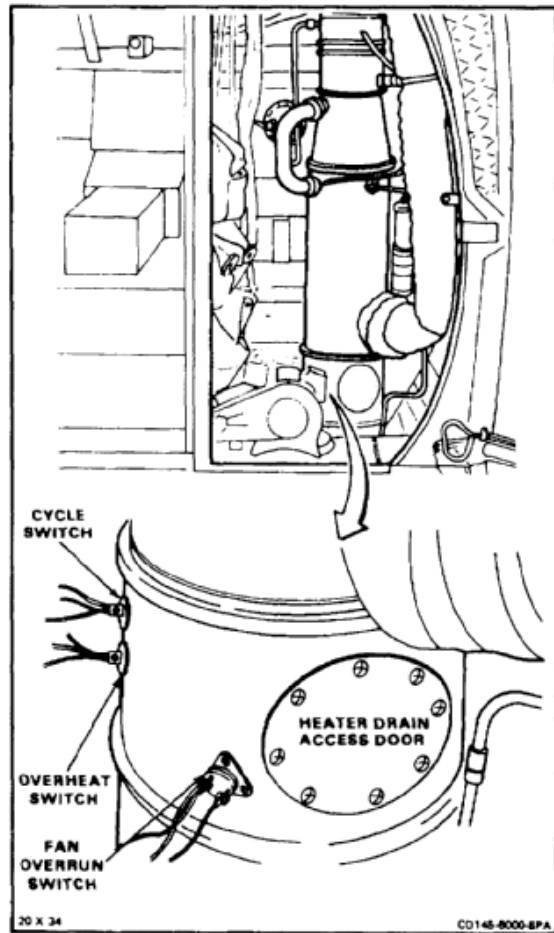

**NOTE**

Removal procedure is same for all three heater thermostatic switches except for wire connections. Overrun and overheat switches have three wires; cycle switch has two. Removal of fan overrun switch is shown here.

1. Tag and disconnect three wires (1) from switch (2) by removing two screws (3). Tape wire ends.

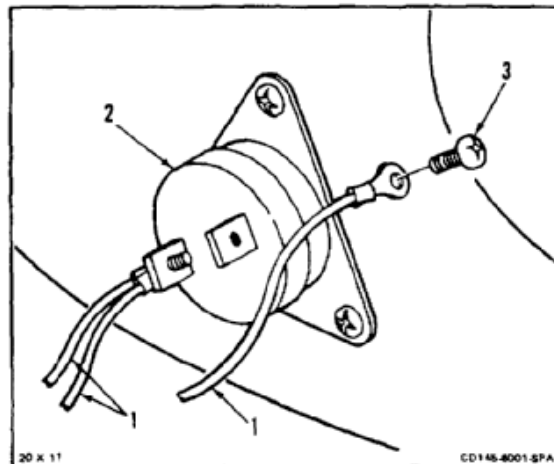

**13-50 REMOVE HEATER THERMOSTATIC SWITCHES (Continued)****13-50**

2. Remove three screws (4).
3. Remove switch (2) from transition duct (5).

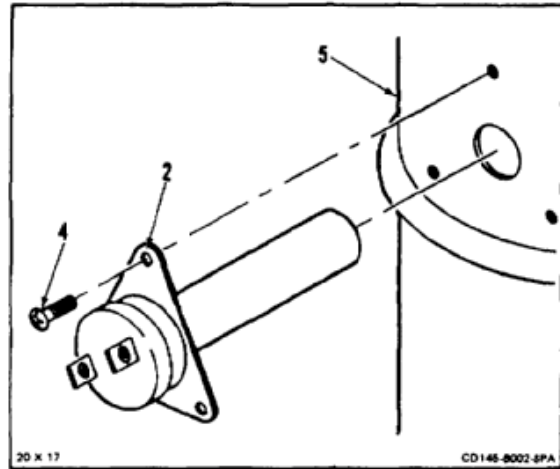
***FOLLOW-ON MAINTENANCE:***

None

END OF TASK

INITIAL SETUP

**Applicable Configurations:**

All

**Tools:**

Aircraft Mechanic's Tool Kit, NSN 5180-00-323-4692

**Materials:**

None

**Personnel Required:**

Medium Helicopter Repairer  
Inspector

**References:**

TM 55-1520-240-23P

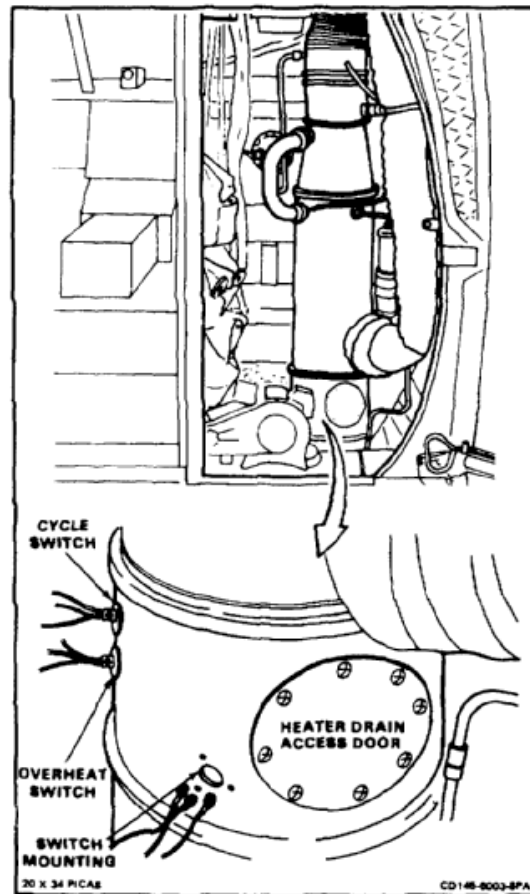

**NOTE**

Installation procedure is same for all three heater thermostatic switches except for wire connections. Overrun and overheat switches have three wires; cycle switch has two. Installation of fan overrun switch is shown here.

1. Slide switch (1) into transition duct (2).
2. Install three screws (3).

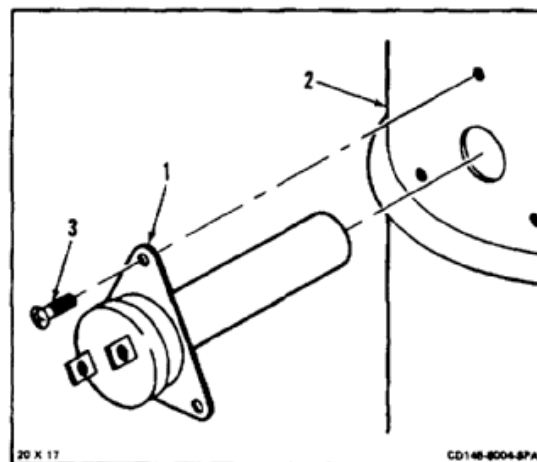



**13-51 INSTALL HEATER THERMOSTATIC SWITCHES (Continued)****13-51**

3. Remove tape. Connect three wires (4) to switch (1) by installing two screws (5). Remove tags.

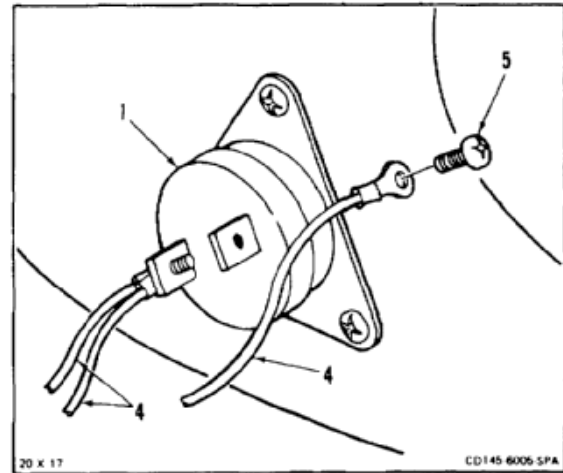
**INSPECT****FOLLOW-ON MAINTENANCE:**

Perform operational check (TM 55-1520-240-T).  
Install heater compartment acoustic blanket (Task 2-210).

END OF TASK

INITIAL SETUP

**Applicable Configurations:**

All

**Tools:**

Aircraft Mechanic's Tool Kit, NSN 5180-00-323-4692

**Materials:**

None

**Personnel Required:**

Medium Helicopter Repairer

**Equipment Condition:**

- Battery Disconnected (Task 1-39)
- Electrical Power Off
- Heater Compartment Acoustic Blanket Removed (Task 2-208)

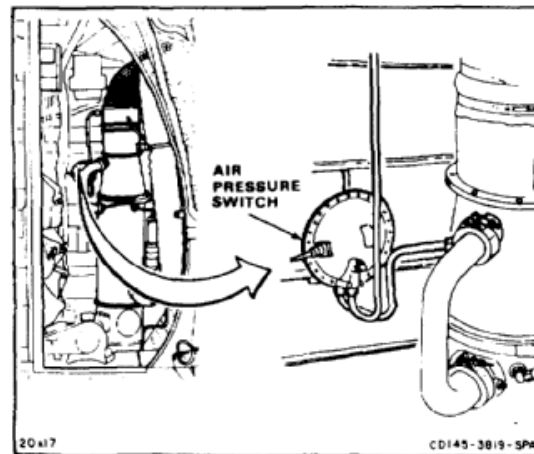

1. Disconnect two tubes (1) from switch (2).
2. Remove lockwire and disconnect electrical connector (3).
3. Remove three nuts (4) and washers (5) from back of switch (2).

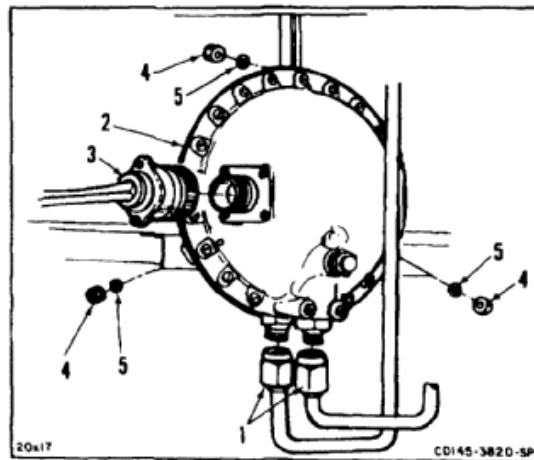

4. Remove switch (2).
5. Remove two nipples (6). Remove packings (7) from nipples.

**FOLLOW-ON MAINTENANCE:**

None

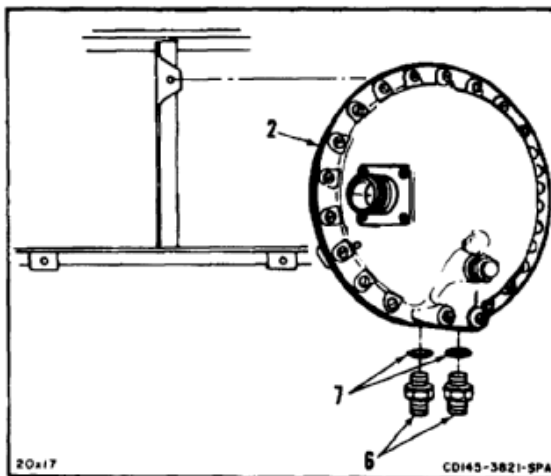

END OF TASK

INITIAL SETUP

**Applicable Configurations:**

All

**Tools:**

Aircraft Mechanic's Tool Kit, NSN 51 80-00-323-4692

**Materials:**

Lockwire (E231)

**Parts:**

Packings

**Personnel Required:**

Medium Helicopter Repairer  
Inspector

**References:**

TM 55-1520-240-23P

1. Install two packings (1) on nipples (2). Install nipples in switch (3).

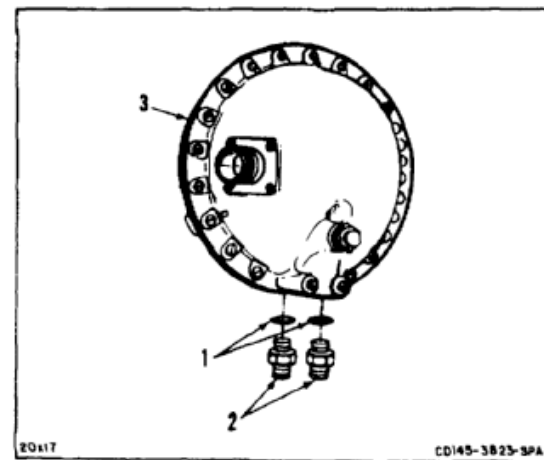
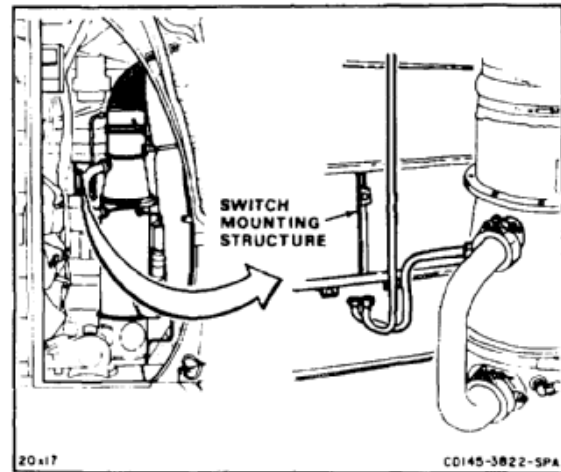

2. Position switch (3) on structure (4).
3. Install three nuts (5) and washers (6) on back of switch (3).
4. Connect electrical connector (7). Lockwire connector. Use lockwire (E231).
5. Connect two tubes (8).

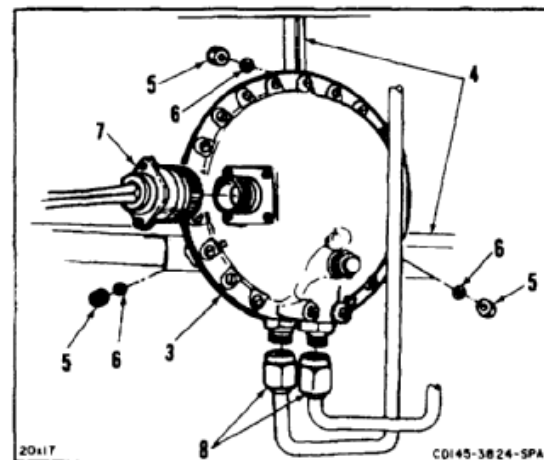

**INSPECT**

**FOLLOW-ON MAINTENANCE:**

Perform operational check (TM 55-1520-240-T).  
Install heater compartment acoustic blanket (Task 2-210).

END OF TASK

## INITIAL SETUP

**Applicable Configurations:**

All

**Tools:**

Aircraft Mechanic's Tool Kit, NSN 5180-00-323-4692

**Materials:**

None

**Personnel Required:**

Medium Helicopter Repairer

**Equipment Condition:**

Battery Disconnected (Task 1-39)

Electrical Power Off

Heater Compartment Acoustic Blanket Removed  
(Task 2-208)

Temperature Controller Removed (Task 13-58)

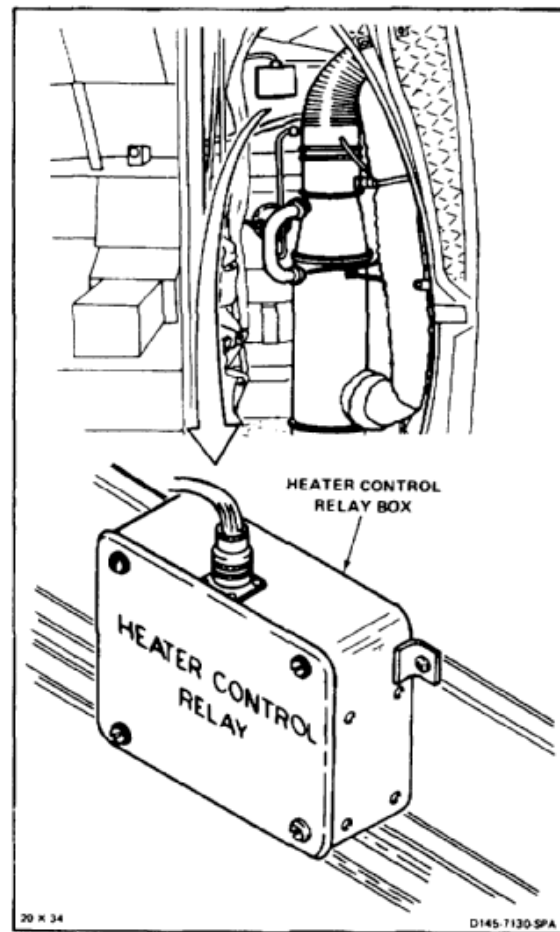

1. Disconnect electrical connector (1) from heater control relay box (2).
2. Remove four screws (3), washers (4), four clamps (5), and two spacers (6) from relay box (2). Remove relay box.

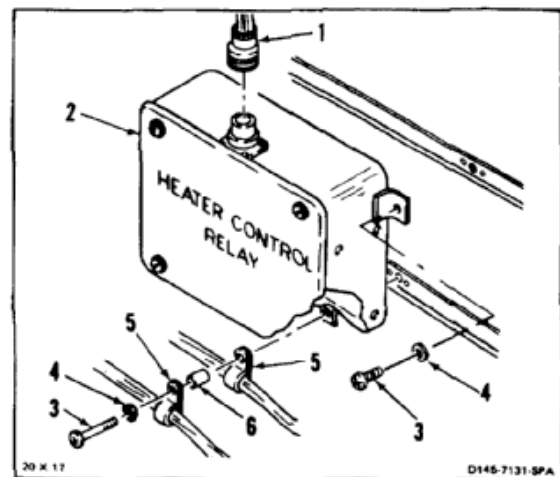
**FOLLOW-ON MAINTENANCE:**

None

END OF TASK

13-160

## INITIAL SETUP

**Application Configurations:**

All

**Tools:**

Electrical Repairer's Tool Kit, NSN 5180-00-323-4915  
Soldering iron

**Materials:**

Paper Tags (E264)  
Tape (E385)

**Personnel Required:**

Aircraft Electrician

**Equipment Condition:**

Off Helicopter Task

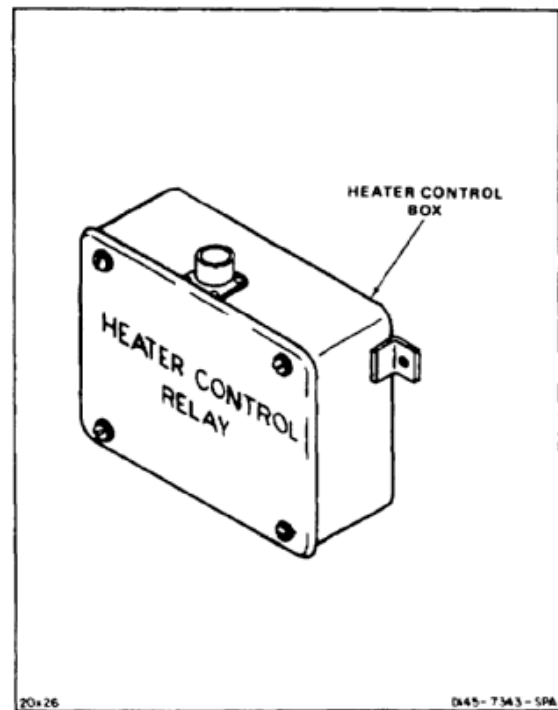

1. Remove four screws (1), washers (2), and cover (3) from heater control box (4).

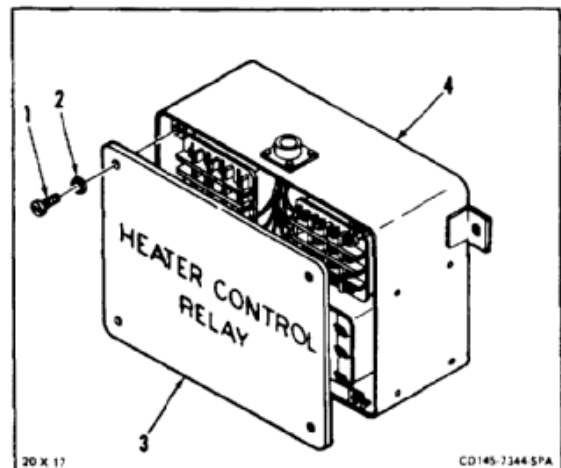

**REMOVE HEATER CONTROL RELAY**

2. Tag 10 wires (5) on heater control relay (6). Remove 8 screws (7), washers (8), and wires. Tape exposed ends of wires. Use tape (E385).
3. Remove four screws (9), washers (10), and relay (6) from box (4).

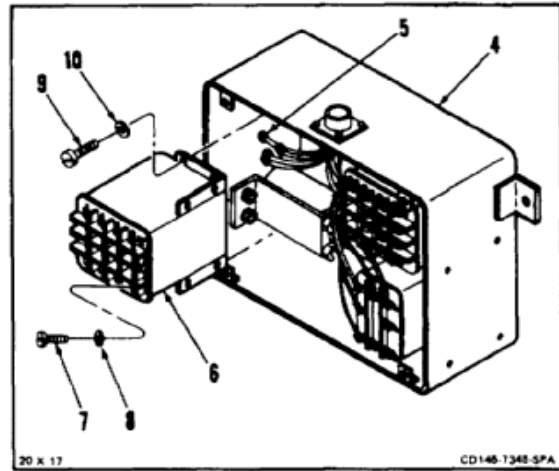

**REMOVE OVERHEAT RELAY**

4. Tag 11 wires (11) on overheat relay (12). Remove 8 screws (13), 8 washers (14), and 11 wires. Tape exposed ends of wires. Use tape (E385).
5. Remove four screws (15), washers (16), and relay (12) from box (4).

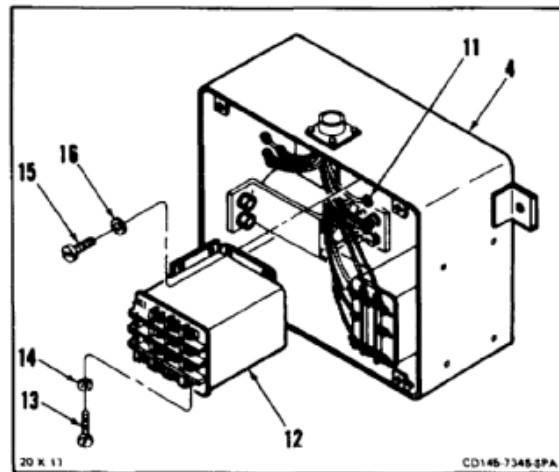

**REMOVE AIR PRESSURE RELAY**

6. Tag four wires (17) on air pressure relay (18). Remove four screws (19), washer (20), and wires. Tape exposed ends of wires. Use tape (E385).
7. Remove two screws (21), washers (22), and relay (18) from box (4).

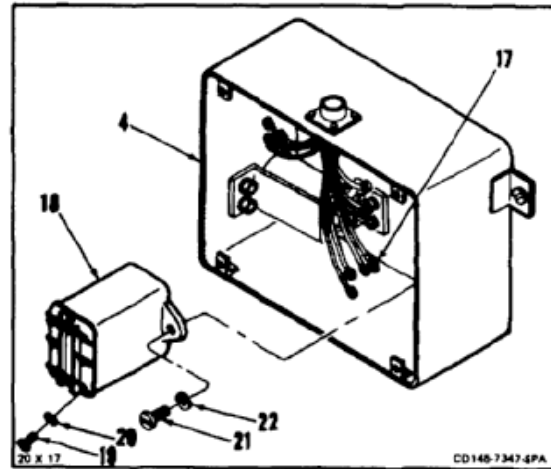
**REMOVE TIME DELAY RELAY**

8. Remove four screws (23), washers (24), two nuts (25), and support (26) from box.
9. Remove four nuts (27), washers (28), and time delay relay (29) from support (26).
10. Cut insulation tubing (30) from six wires (31).
11. Tag six wires (31). Unsolder six wires from time delay relay (29). Tape exposed ends of wires. Use tape (E385).

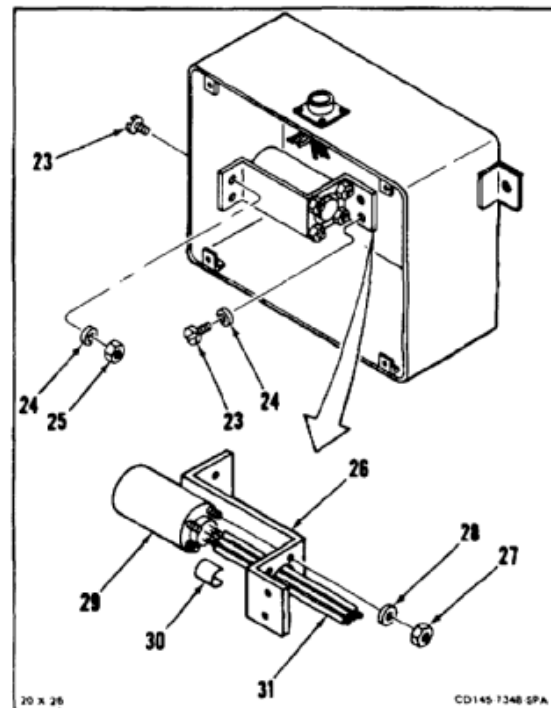
**FOLLOW-ON MAINTENANCE:**

None

END OF TASK

INITIAL SETUP

**Applicable Configurations:**

All

**Tools:**

Electrical Repairer's Tool Kit, NSN 5180-00-323-4915  
Soldering Gun  
Heat Gun

**Materials:**

Solder (E360)  
Insulation Tubing (E431)

**Personnel Required:**

Aircraft Electrician  
Inspector

**References:**

TM 55-1520-240-23P

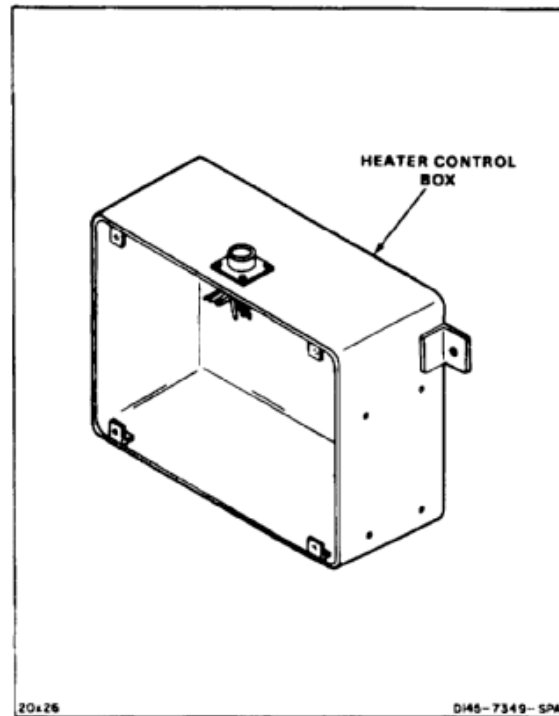

**INSTALL TIME DELAY RELAY**

1. Insert six wires (1) through support (2). Remove tape from wires.
2. Slide insulation tubing (3) on wires (1). Use tubing (E431).
3. Connect six wires (1) to time delay relay (4). Use solder (E360). Remove tags.
4. Slide tubing (3) over terminals of relay (4). Shrink tubing with heat gun.
5. Position relay (4) in support (2). Install four washers (5) and nuts (6).
6. Position support (2) in heater control box (7). Install four screws (8), washers (9), and two nuts (10).

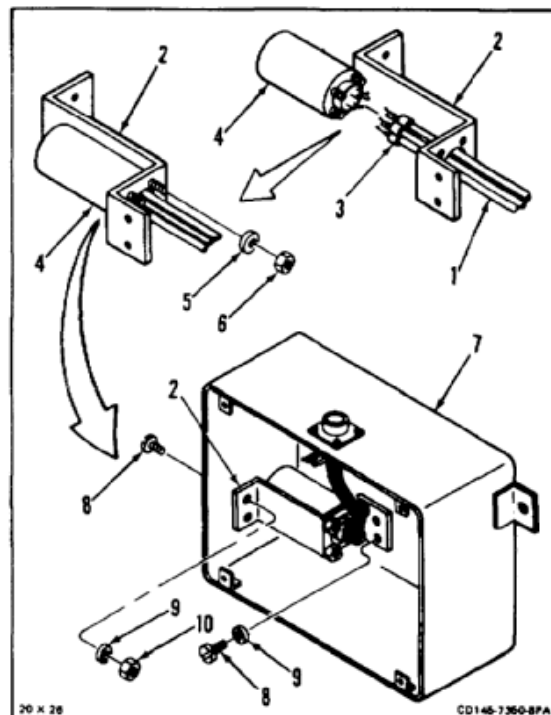



**INSTALL AIR PRESSURE RELAY**

7. Position air pressure relay (11) with X2 terminal up, in box (7). Install two screws (12) and washers (13).
8. Remove tape from four wires (14).
9. Connect four wires (14) to relay (11). Install four screws (15) and washers (16). Remove tags.

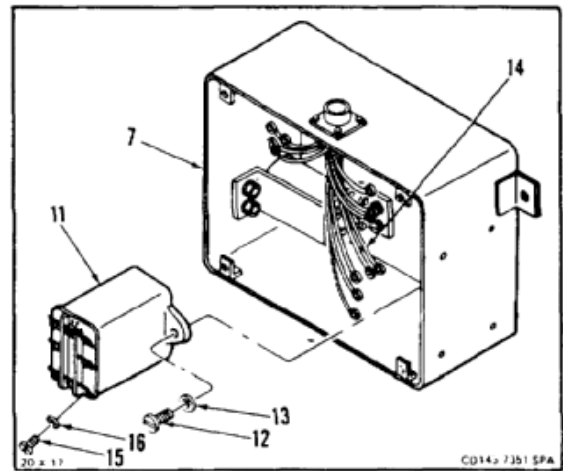

**INSTALL OVERHEAT RELAY**

10. Position overheat relay (17) with X1 terminal up, in box (7). Install four screws (18) and washers (19).
11. Remove tape from 11 wires (20).
12. Connect 11 wires (20) to relay (17). Install 8 screws (21) and washers (22). Remove tags.

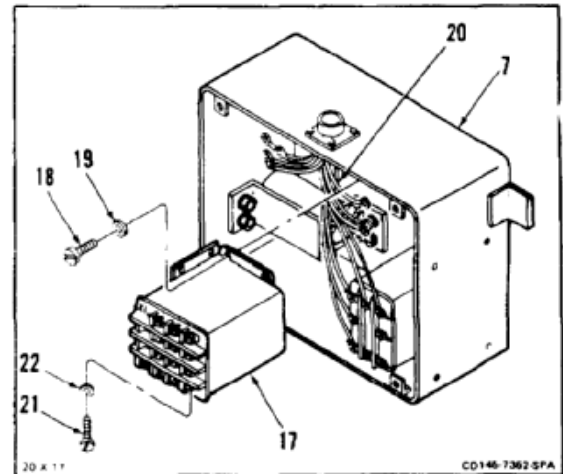

**INSTALL HEATER CONTROL RELAY**

13. Position heater control relay (23) with X2 terminal up, in box (7). Install four screws (24) and washers (25).
14. Remove tape from 10 wires (26).
15. Connect 10 wires (26) to relay (23). Install 8 screws (27) and washers (28). Remove tags.

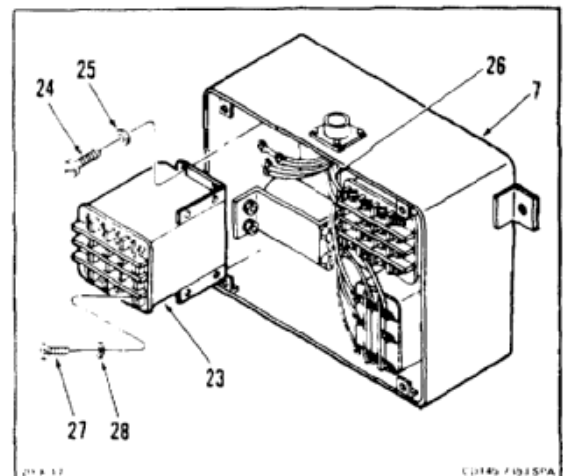

**INSPECT**

16. Position cover (29) on box (7). Install four screws (30) and washers (31).

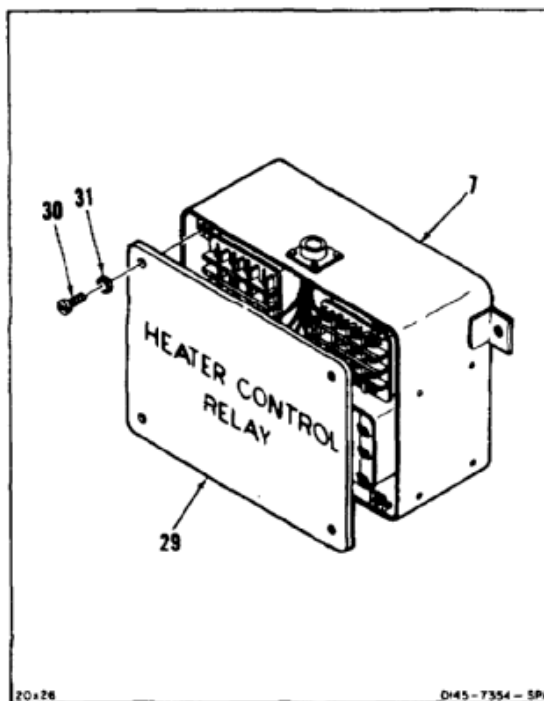

**FOLLOW-ON MAINTENANCE:**

None

END OF TASK

13-166

**13-57 INSTALL HEATER CONTROL RELAY BOX**

13-57

**INITIAL SETUP****Applicable Configurations:**

All

**Tools:**

Aircraft Mechanic's Tool Kit, NSN 5180-00-323-4692

**Materials:**

Cloths (E120)  
 Gloves (E186)  
 Methyl-Ethyl-Ketone (E244)

**Personnel Required:**

Medium Helicopter Repairer  
 Inspector

**References:**

TM 55-1520-240-23P

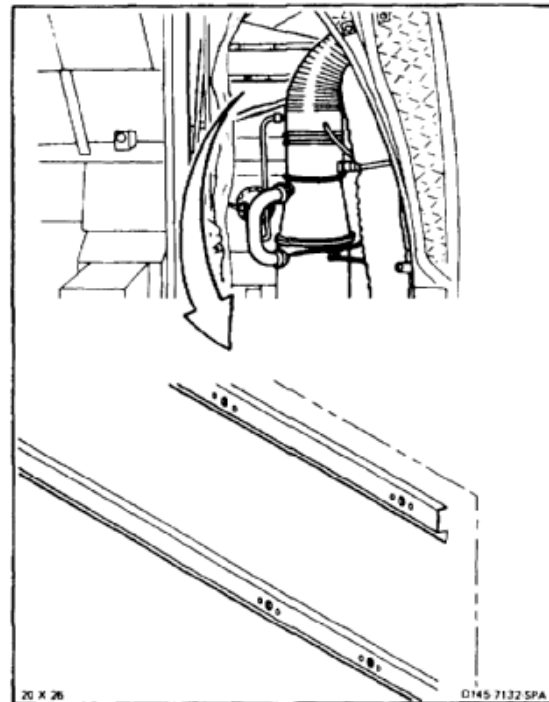
**WARNING**

Methyl-ethyl-ketone (E244) is flammable and toxic. It can irritate skin and cause burns. Use only in well-ventilated area, away from heat and open flame. In case of contact, immediately flush skin or eyes with water for at least **15 minutes**. Get medical attention for eyes.

1. Clean bonding points on heater control relay box (1) and structure (2). Use methyl-ethyl-ketone (E244) and cloths (E120). Wear gloves (E186).
2. Align holes in heater control relay box (1) and structure (2). Install four screws (3), washers (4), four clamps (5), and two spacers (6).
3. Connect electrical connector (7) to heater control relay box (1).

**INSPECT****FOLLOW-ON MAINTENANCE:**

Install temperature controller (Task 13-59).  
 Perform operational check of heating system (TM 55-1520-240-T).  
 Install heater compartment acoustic blanket (Task 2-210).

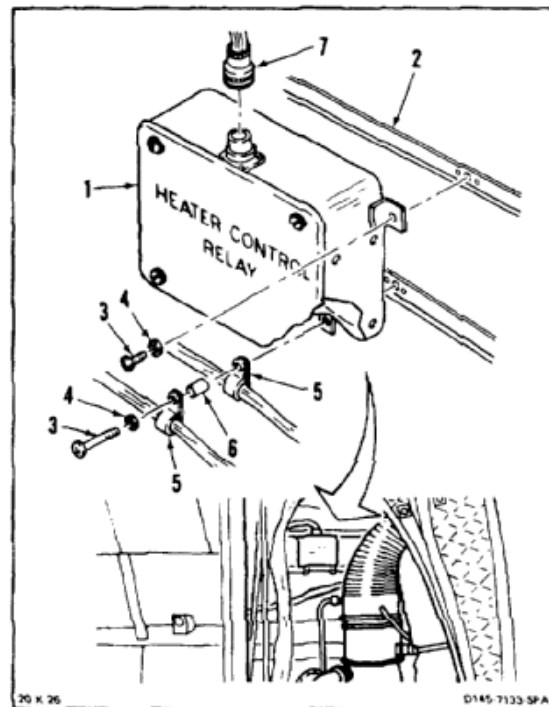

END OF TASK

INITIAL SETUP

**Applicable Configurations:**

All

**Tools:**

Aircraft Mechanic's Tool Kit, NSN 5180-00-323-4692

**Materials:**

None

**Personnel Required:**

Medium Helicopter Repairer

**Equipment Condition:**

Battery Disconnected (Task 1-39)

Electrical Power Off

Heater Compartment Acoustic Blanket Removed  
(Task 2-208)

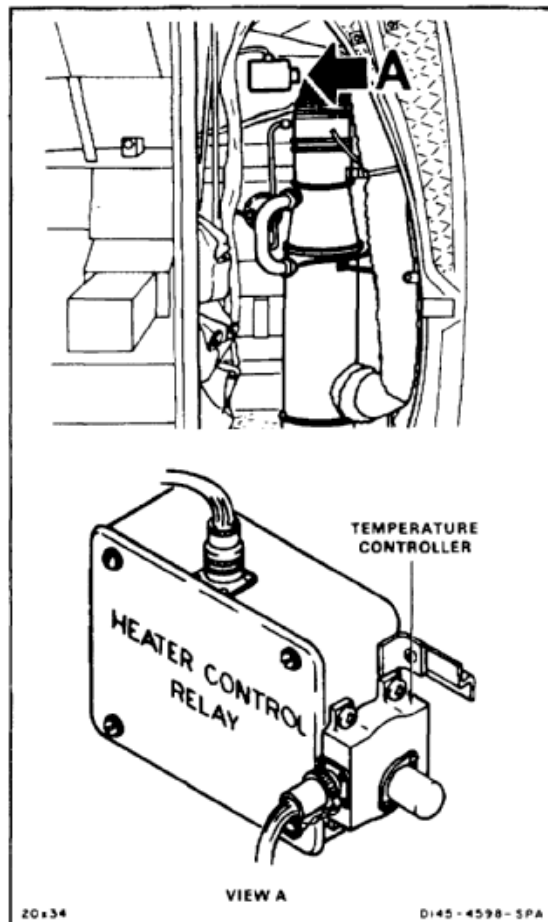

1. Remove lockwire and disconnect electrical connector (1).
2. Remove four screws (2) and washers (3).  
Remove temperature controller (4).

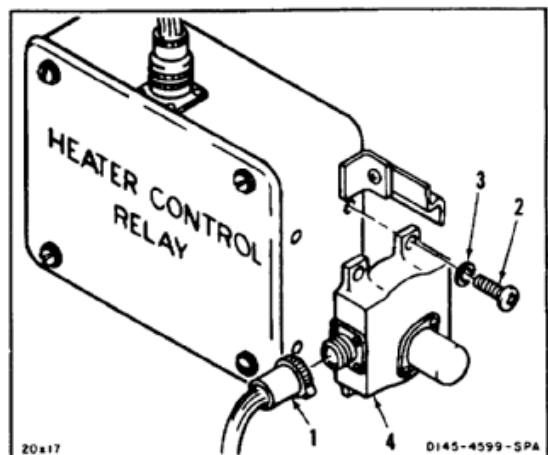

**FOLLOW-ON MAINTENANCE:**

None

END OF TASK

INITIAL SETUP

**Applicable Configurations:**

All

**Tools:**

Aircraft Mechanic's Tool Kit, NSN 51 80-00-323-4692

**Materials:**

Lockwire (E231)

**Personnel Required:**

Medium Helicopter Repairer  
Inspector

**References:**

TM 55-1520-240-23P

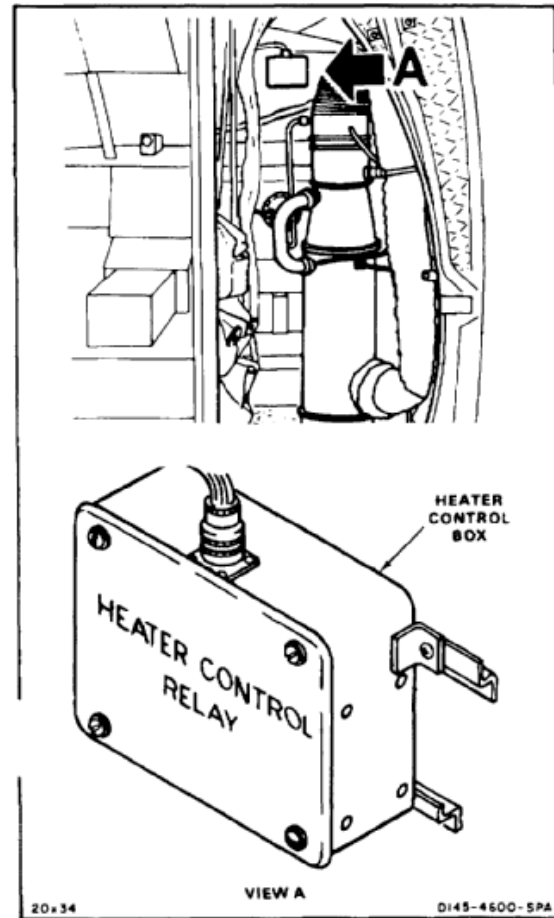

1. Position temperature controller (1) on heater control box (2).
2. Install four screws (3) and washers (4).

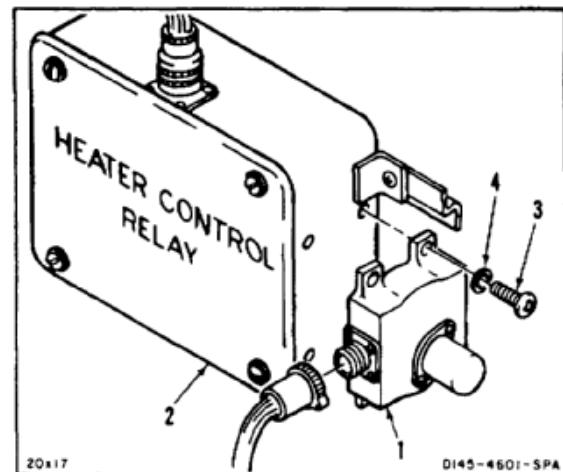

3. Connect electrical connector (5).
4. Lockwire connector (5) to screw (6) in heater control box (2). Use lockwire (E231).

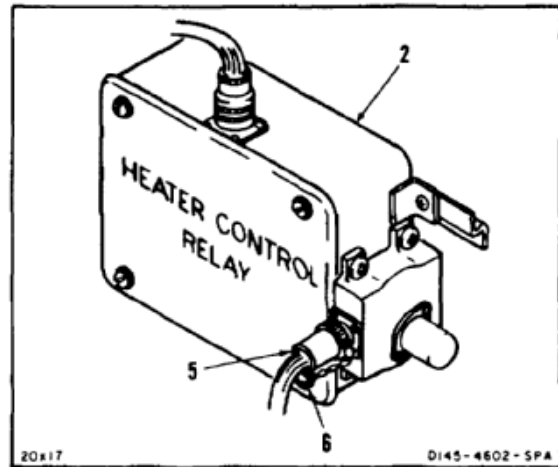
**INSPECT****FOLLOW-ON MAINTENANCE:**

Perform operational check (TM 55-1520-240-T).  
Install heater compartment acoustic blanket (Task 2-210).

END OF TASK

13-170

INITIAL SETUP

**Applicable Configurations:**

All

**Tools:**

Aircraft Mechanic's Tool Kit, NSN 5180-00-323-4692

**Materials:**

None

**Personnel Required:**

Medium Helicopter Repairer

**Equipment Condition:**

Battery Disconnected (Task 1-39)  
Electrical Power Off

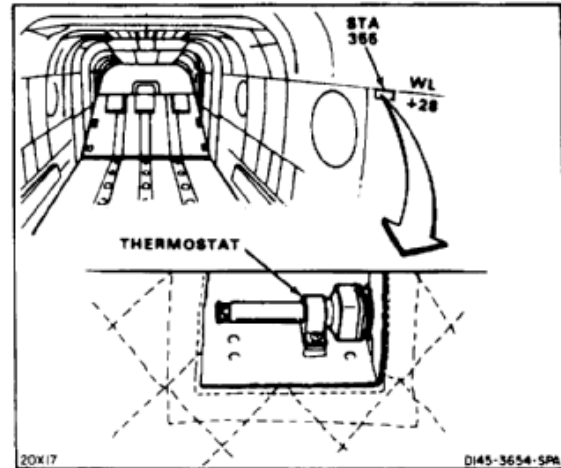

1. Pull blanket (1) away from box (2).
2. Disconnect connector (3) from thermostat (4).

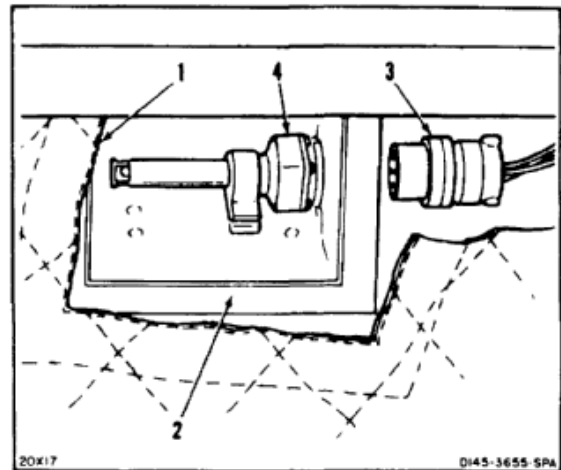

3. Remove two nuts (5) and washers (6) from back of box (2).
4. Remove two screws (7), thermostat (4), and rubber pad (8).

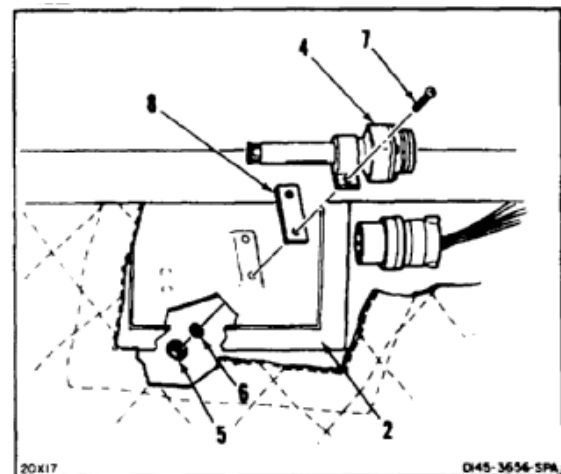

**FOLLOW-ON MAINTENANCE:**

None

END OF TASK

INITIAL SETUP

**Applicable Configurations:**

All

**Tools:**

Aircraft Mechanic's Tool Kit, NSN 5180-00-323-4692

**Materials:**

None

**Personnel Required:**

Medium Helicopter Repairer

**References:**

TM 55-1520-240-23P

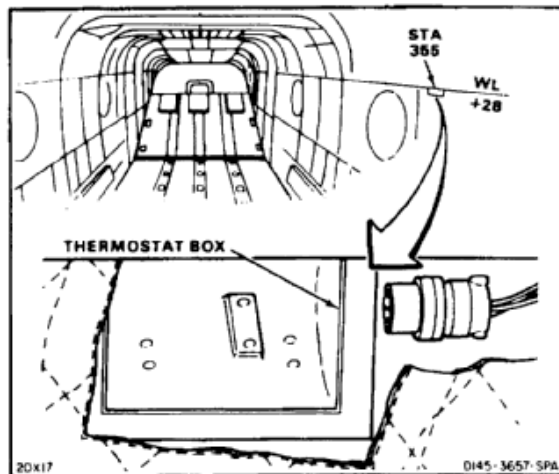

1. Connect connector (1) to thermostat (2).
2. Position thermostat (2) and rubber pad (3) on box (4). Install two screws (5), washers (6), and nuts (7).

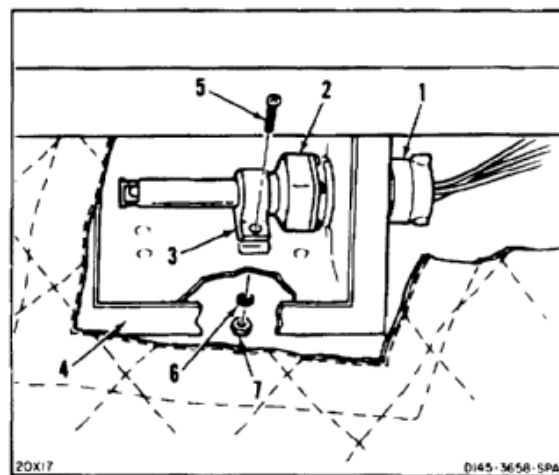

3. Install blanket (8) around box (4).

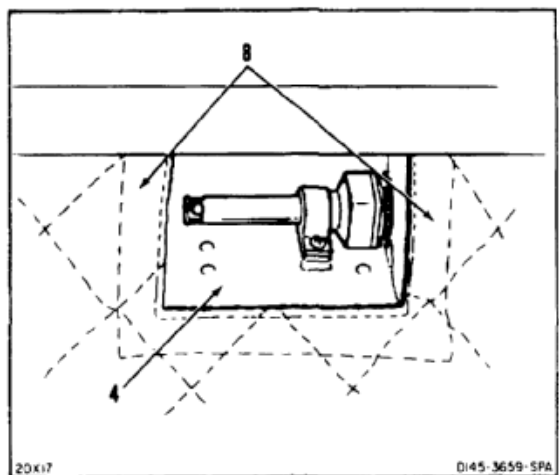

**FOLLOW-ON MAINTENANCE:**

Perform operational check (TM 55-1520-240-T).

END OF TASK



**13-62 REMOVE HEATER FUEL CONTROL**

13-62

**INITIAL SETUP****Applicable Configurations:**

All

**Tools:**

Aircraft Mechanic's Tool Kit, NSN 5180-00-323-4692

**Materials:**

Cloths (E135)  
 Paper Tags (E264)  
 As Required

**Personnel Required:**

Medium Helicopter Repairer

**Equipment Condition:**

Battery Disconnected (Task 1-39)  
 Electrical Power Off  
 Heater Compartment Acoustic Blanket Removed  
 (Task 2-208)  
 Grounded Container, Two Quart

**General Safety Instructions:****WARNING**

All regulations and instructions  
 for handling fuels shall be strictly  
 observed.

1. Remove lockwire and disconnect electrical connector (1).
2. Tag and disconnect two fuel hoses (2). Use container and cloths (E135) for spilled fuel. Plug hoses.
3. Remove reducer (3).
4. Cap ports (4).

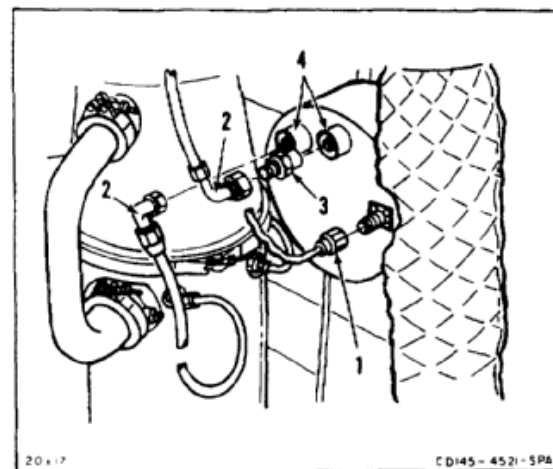
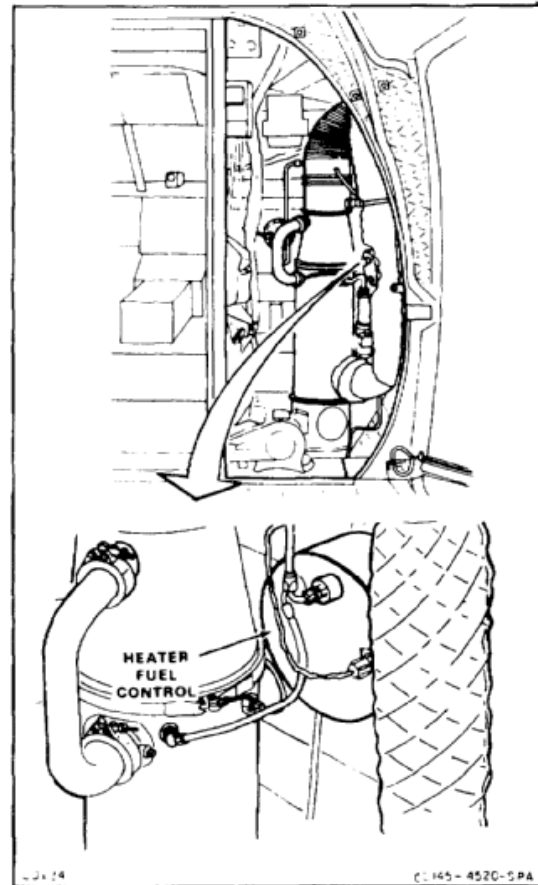

5. Disconnect drain tube (5).
6. Remove 4 bolts (6) and 12 washers (7). Remove control (8).
7. Plug drain tube (5) and cap port (9).

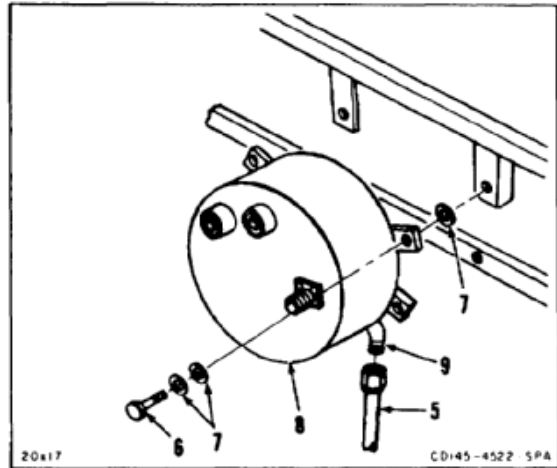
***FOLLOW-ON MAINTENANCE:***

None

END OF TASK

**13-174**

INITIAL SETUP

**Applicable Configurations:**

All

**Tools:**

Aircraft Mechanic's Tool Kit, NSN 51 80-00-323-4692

**Materials:**

Lockwire (E229)

**Personnel Required:**

Medium Helicopter Repairer  
Inspector

**References:**

TM 55-1520-240-23P

**General Safety Instructions:**

**WARNING**

All regulations and instructions for handling fuels shall be strictly observed.

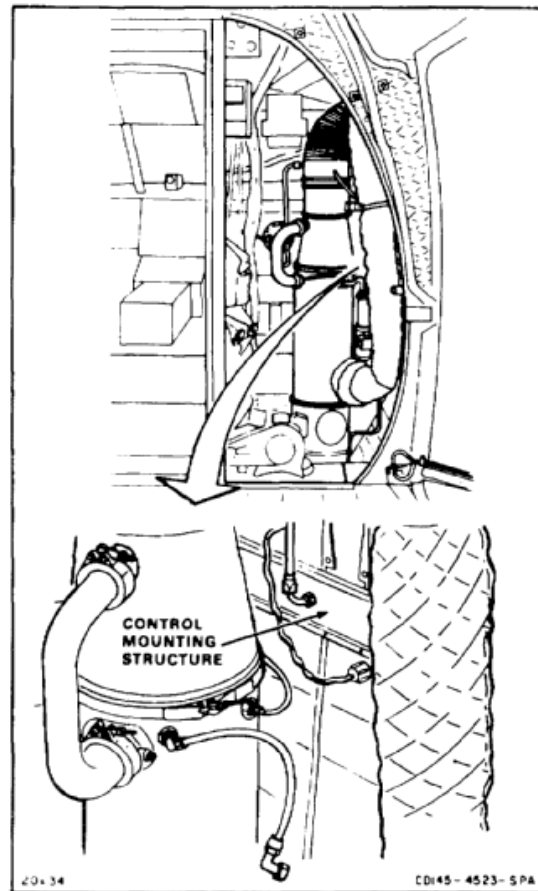

1. Remove plug from drain tube (1) and cap from DRAIN port (2).
2. Position control (3) on mounting structure (4).
3. Install 4 bolts (5) and 12 washers (6).
4. Connect drain tube (1) to drain port (2).

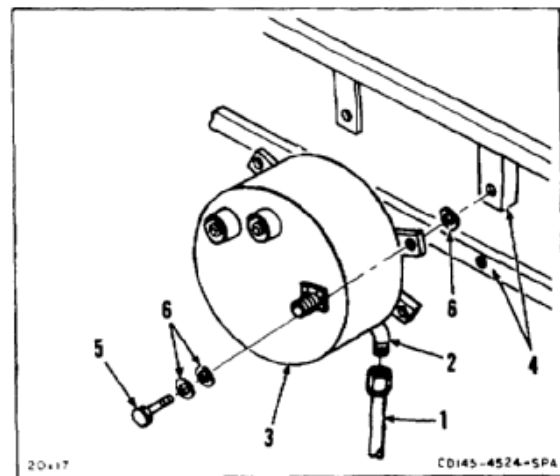

5. Remove plug from hose (7) and cap from FUEL OUTLET port (8). Connect hose to port. Remove tag from hose.
6. Remove cap from FUEL INLET port (9). Install reducer (10) in port.
7. Remove plug from hose (11). Connect hose to reducer (10). Remove tag from hose.

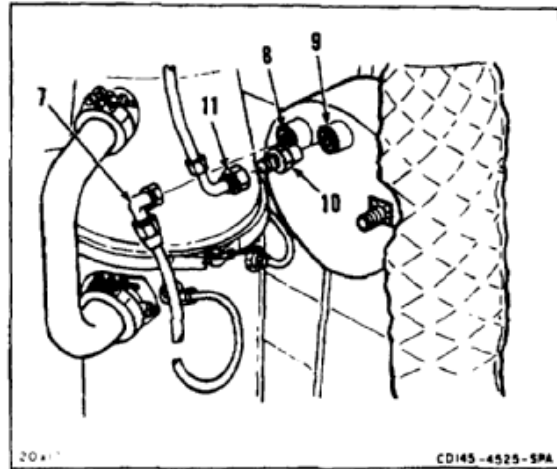

8. Connect electrical connector (12).
9. Install lockwire (E229) on connector (12).

**INSPECT**

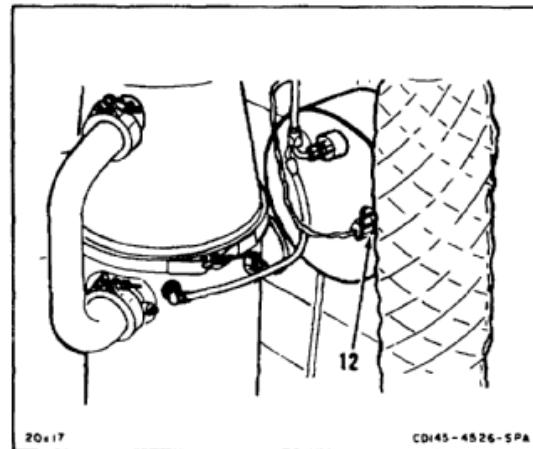

**FOLLOW-ON MAINTENANCE:**

Perform operational check (TM 55-1520-240-T).  
Install heater compartment acoustic blanket (Task 2-210).

END OF TASK

13-176

## INITIAL SETUP

**Applicable Configurations:**

All

**Tools:**

None

**Materials:**

None

**Parts:**

Fuse

**Personnel Required:**

Medium Helicopter Repairer

**References:**

TM 55-1520-240-23P

**Equipment Condition:**

Battery Disconnected (Task 1-39)  
 Electrical Power Off  
 Heater Compartment Acoustic Blanket Removed  
 (Task 2-208)

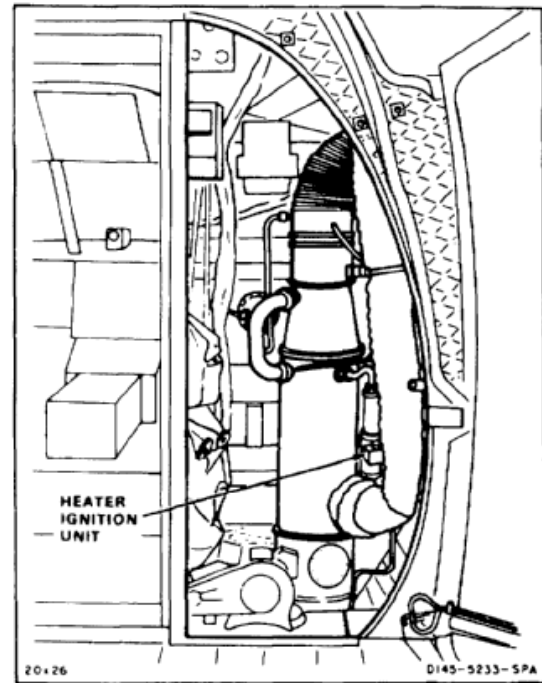

1. Remove extractor (1) from ignition unit (2).
2. Remove fuse (3) from extractor (1). Install serviceable fuse.
3. Install extractor (1).

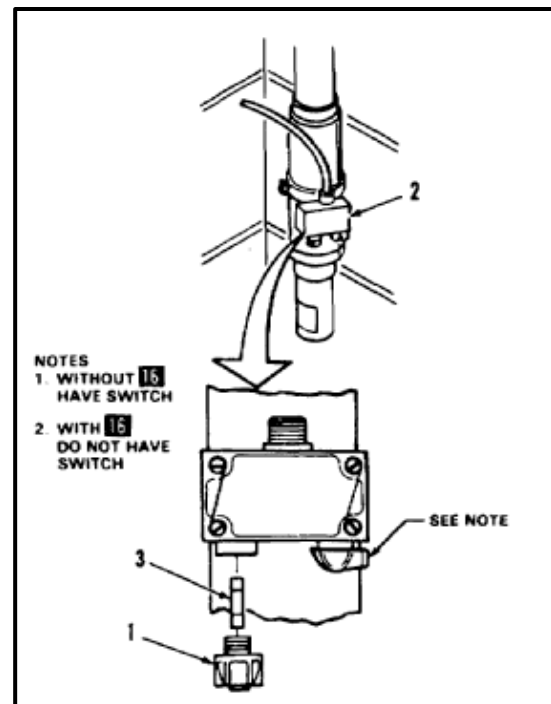
**FOLLOW-ON MAINTENANCE:**

Install heater compartment acoustic blanket (Task 2-210).

END OF TASK

INITIAL SETUP

**Applicable Configurations:**

All

**Tools:**

Aircraft Mechanic's Tool Kit, NSN 5180-00-323-4692

**Materials:**

None

**Personnel Required:**

Medium Helicopter Repairer

**Equipment Condition:**

Battery Disconnected (Task 1-39)

Electrical Power Off

Heater Compartment Acoustic Blanket Removed  
(Task 2-208)

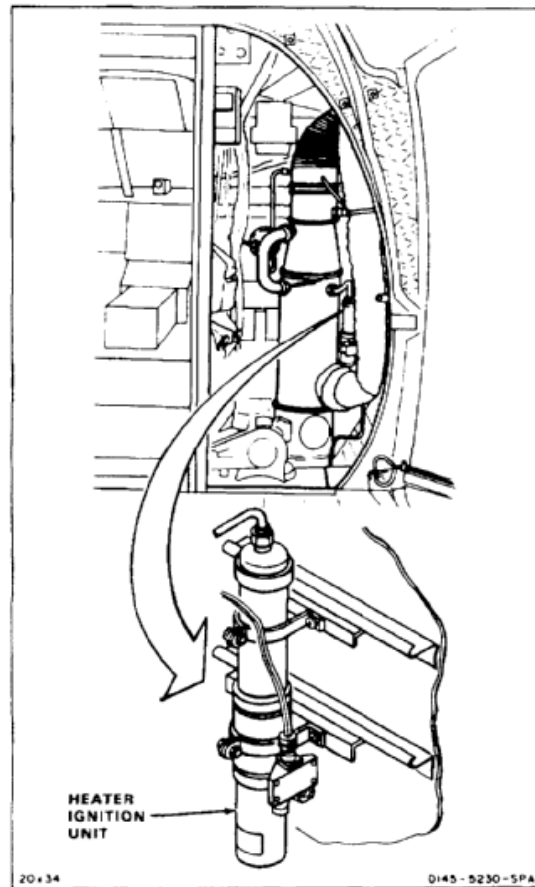

1. Remove lockwire and disconnect electrical connector (1).
2. Disconnect shielded lead (2).
3. Remove two screws (3) and washers (4).

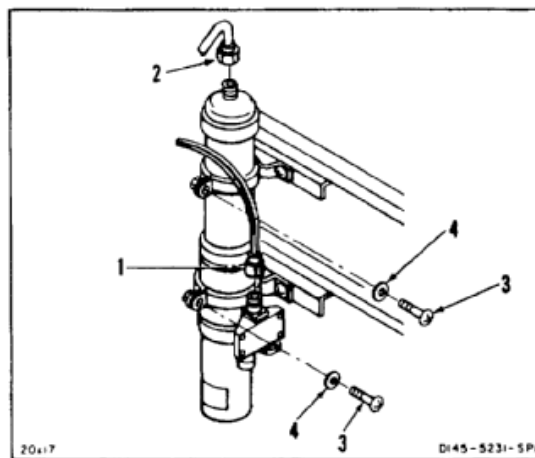

**13-65 REMOVE HEATER IGNITION UNIT (Continued)****13-65**

4. Removal ignition unit (5).
5. Remove four screws (6), washers (7), and two brackets from structure (8).

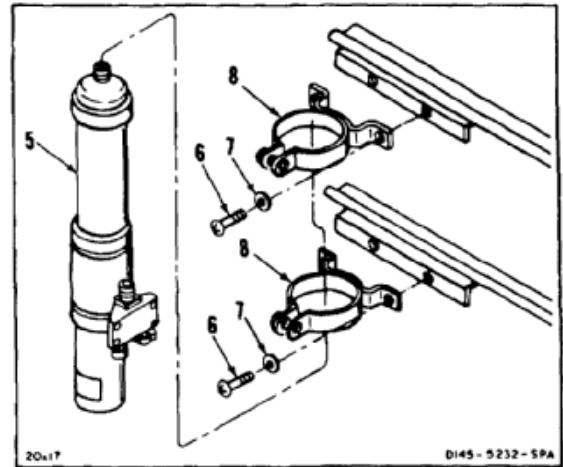
***FOLLOW-ON MAINTENANCE:***

None

END OF TASK

INITIAL SETUP

**Applicable Configurations:**

All

**Tools:**

Aircraft Mechanic's Tool Kit, NSN 5180-00-323-4692

**Materials:**

Lockwire (E231)

**Personnel Required:**

Medium Helicopter Repairer  
Inspector

**References:**

TM 55-1520-240-23P

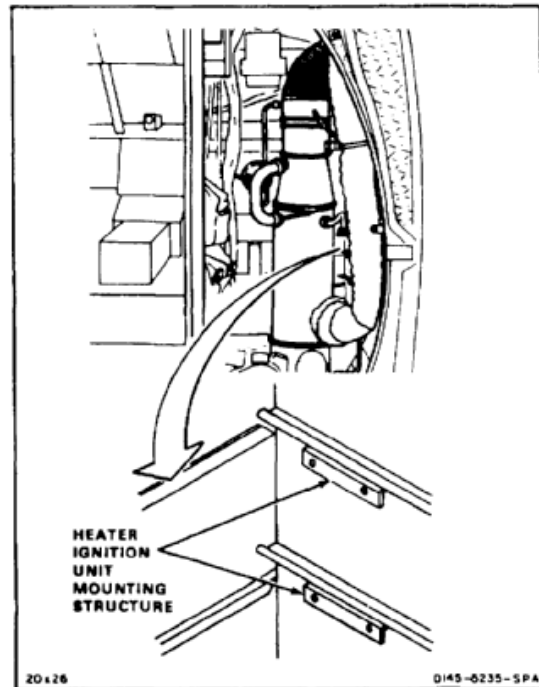

1. Align holes in small diameter bracket (1), large diameter bracket (2), and structure (3).
2. Install four screws (4) and washers (5).

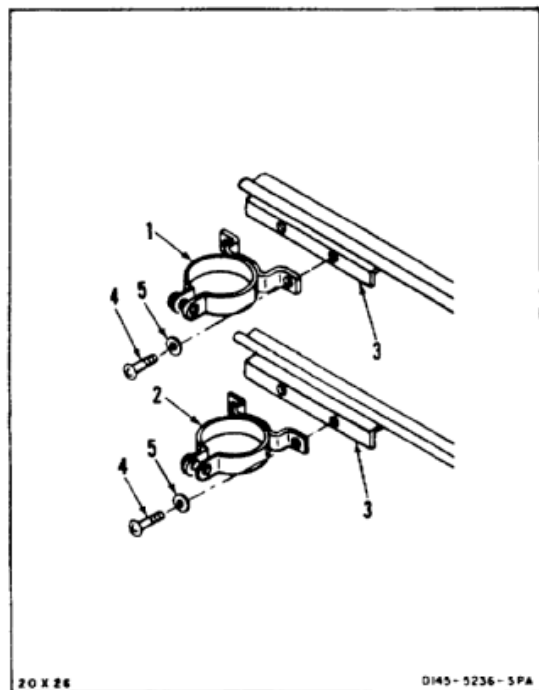



3. Position ignition unit (6) in brackets (1 and 2) as shown.

**NOTE**

Without **16** have switch (6.1). With **16** do not have switch (6.1).

4. Install two screws (7) and washers (8).
5. Connect shielded lead (9).
6. Connect electrical connector (10).

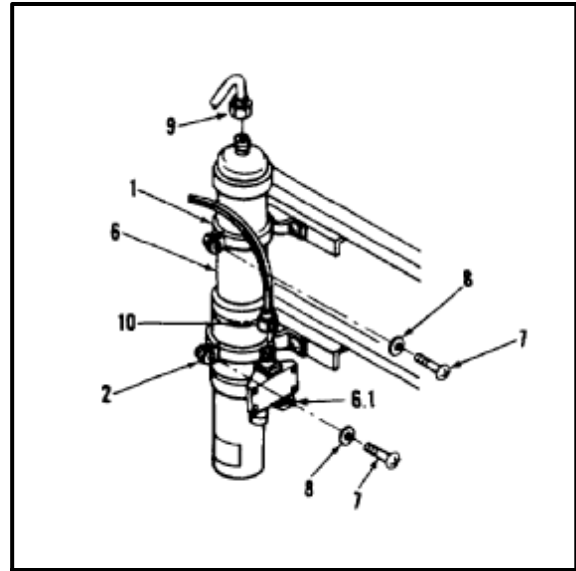

7. Lockwire connector (10). Use lockwire (E231).

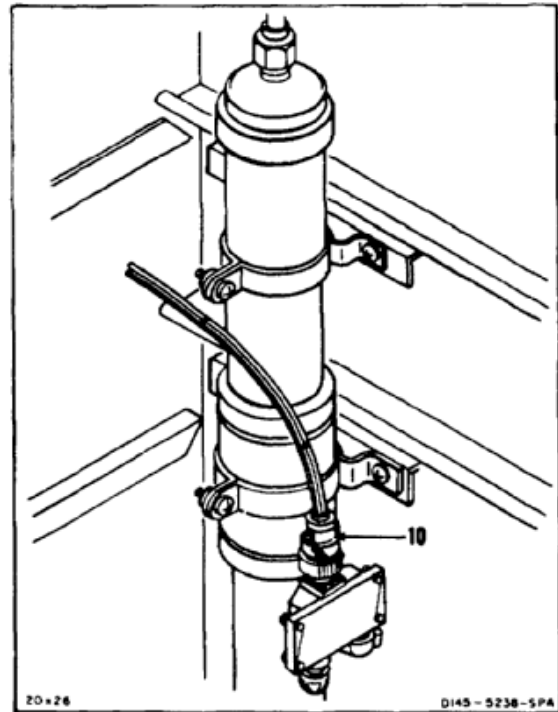
**INSPECT****FOLLOW-ON MAINTENANCE:**

Perform operational check (TM 55-1520-240-T).  
Install heater compartment acoustic blanket (Task 2-210).

END OF TASK

## INITIAL SETUP

**Applicable Configurations:**

All

**Tools:**

Aircraft Mechanic's Tool Kit, NSN 5180-00-323-4692

**Materials:**

None

**Personnel Required:**

Medium Helicopter Repairer

**Equipment Condition:**

Battery Disconnected (Task 1-39)

Electrical Power Off

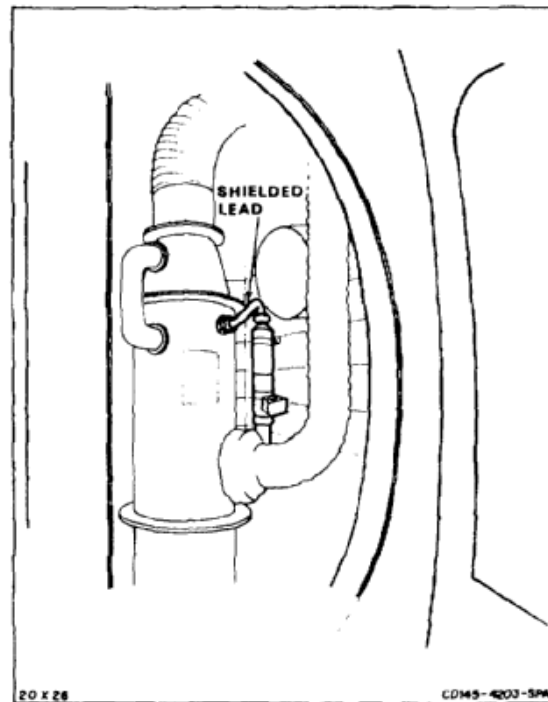
Heater Compartment Acoustic Blanket Removed  
(Task 2-208)

1. Disconnect shielded lead (1) from ignition unit (2).
2. Disconnect lead (1) from spark igniter (3).
3. Remove lead (1).

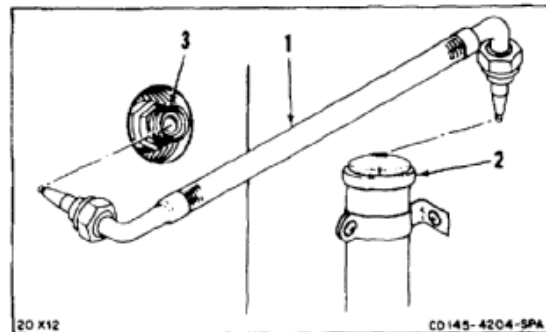
**FOLLOW-ON MAINTENANCE:**

None

END OF TASK

## INITIAL SETUP

**Applicable Configurations:**

All

**Tools:**

Aircraft Mechanic's Tool Kit, NSN 5180-00-323-4692

**Materials:**

None

**Personnel Required:**Medium Helicopter Repairer  
Inspector**References:**

TM 55-1520-240-23P

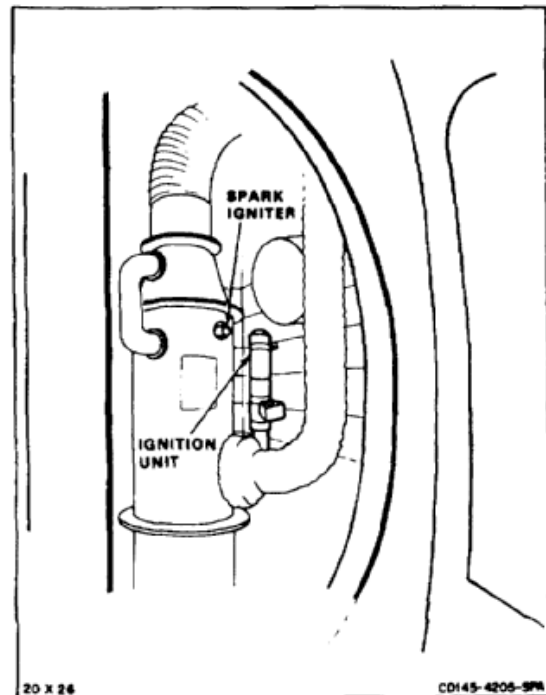

1. Connect shielded lead (1) to ignition unit (2).
2. Connect other end of lead (1) to spark igniter (3).

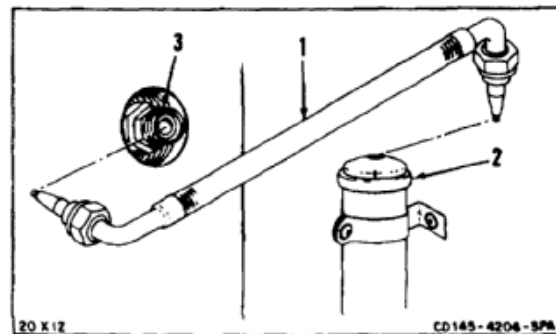
**INSPECT****FOLLOW-ON MAINTENANCE:**

Perform operational check (TM 55-1520-240-T).  
Install heater compartment acoustic blanket (Task 2-210).

END OF TASK



# **CHAPTER 14**

# **HOISTS AND WINCHES**

## **SECTION I**

### **CARGO HANDLING SYSTEM DESCRIPTION AND THEORY OF OPERATION**

**DESCRIPTION**

The cargo handling system consists of a hydraulically-operated winch and cable, a cable cutter, tackle blocks, and a remote-control grip and safety harness. Stowage bags in the heater compartment are provided for the cable cutter and tackle blocks when not in use. System power and control is provided through various hydraulic valves and electrical switches and receptacles.

The heart of the cargo handling system is the winch, mounted to the floor of the heater compartment at the right forward corner of the cabin. It is powered by hydraulic pressure from the utility hydraulic system. By changing cable routing, the winch can be used to perform several different functions:

- Loading cargo into the cabin through the open cargo door.
- Carrying or bringing on board cargo through the open rescue hatch while in the air.
- Personnel rescue operations.
- Parachute static line retrieval.

Refer to TM 55-1520-240-10 for information on setting up the system to perform these functions.

The winch has **150 feet** of **1/4 inch** steel cable. It has a **3,000 pound** load capacity at a reel-in speed of **20 feet per minute** for cargo loading through the cargo door. For hoisting operations through the rescue hatch, it can lift **600 pounds** at a reel-in speed of **100 feet per minute**. For cargo loading, the effective winch capacity can be increased by routing the cable through the cable blocks as described in TM 55-1520-240-10.

The winch system can be operated from either the cockpit or the cabin. Cockpit operation is by the HOIST panel on the overhead console. Cabin operation is by a control grip that can be plugged into an operator's panel at sta 320 or receptacles at sta 95 or 502. If power is lost during operation, a winch-mounted brake will automatically lock the cable. During rescue operations, the cable is routed through a cable cutter that is plugged into a receptacle above the rescue hatch. During cargo operation, the cable cutter is stowed in the stowage container and connected to a stowage receptacle in the heater compartment at sta 95.

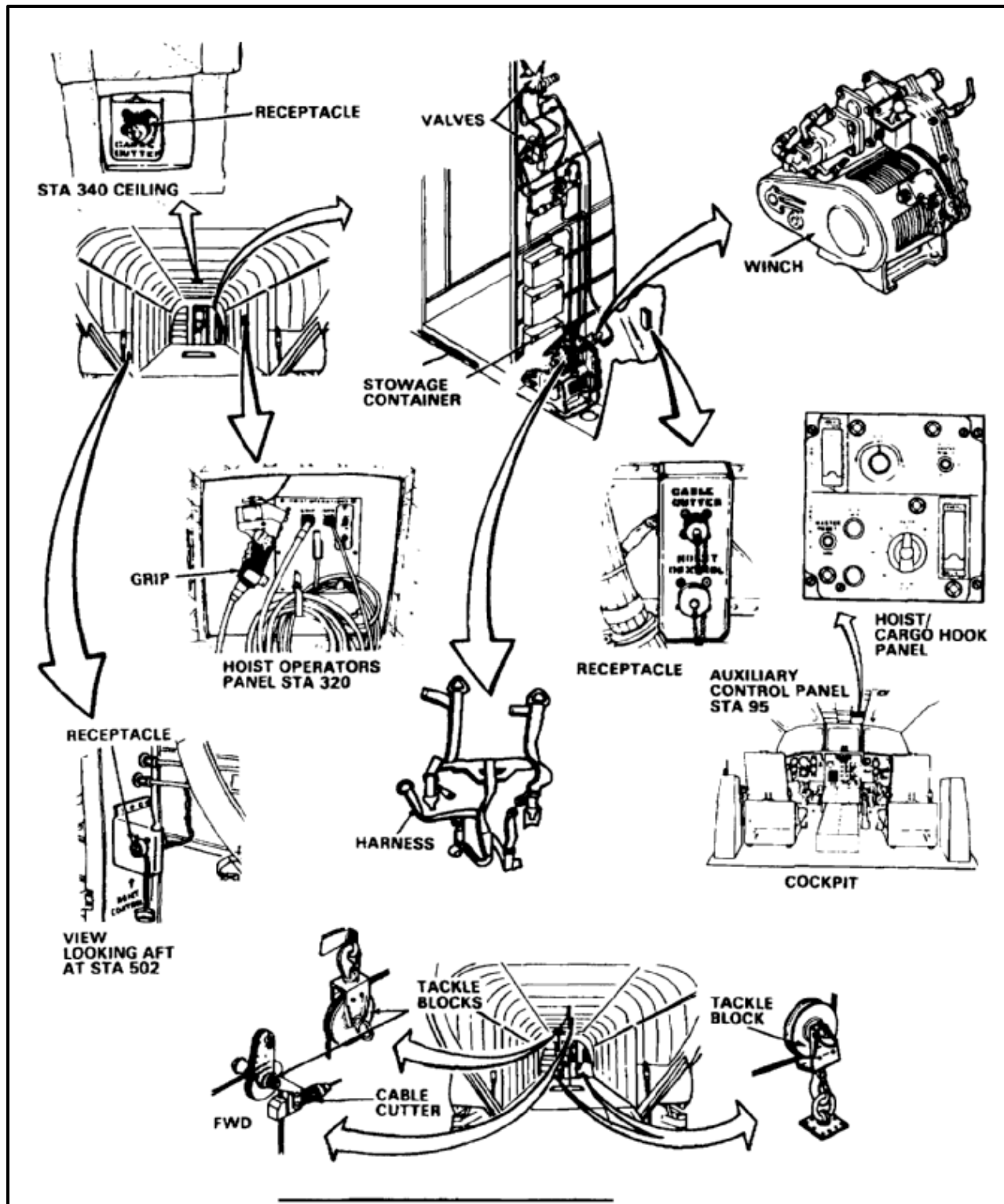

**THEORY OF OPERATION**

The hoist system can be operated from the cockpit or from any of three locations in the cabin. System operation is identical regardless of which location is used. Operation described here is from the cockpit overhead panel, with the winch shifting lever at RESCUE. The control locations in the cabin can be used when the HOIST MASTER switch on the cockpit overhead panel is at REMOTE.

1. Placing the HOIST MASTER switch to PILOT connects **28-volt dc** from the bus to the spring-loaded center-off HOIST rotary switch. The rotary switch has a set of contacts that close whenever the switch is off center. When off center, these contacts energize the winch brake control valve solenoid. When energized, this solenoid directs pressurized hydraulic fluid to release the winch brake and to the P (pressure) port of the winch control valve.
2. Rotating the HOIST switch to OUT energizes the winch control shutoff valve solenoid. At the same time, current flows from the rotary switch to energize the winch control valve OUT solenoid thru the out-limit switch on the winch. Hydraulic fluid from the C1 port of the winch control valve flows thru the pressure reducing valve. This reduces the pressure to **750 psi** before it reaches the OUT port of the winch motor. This pressurized fluid operates the hydraulic motor to reel out the cable. The fluid returns to the system through the IN port of the winch motor to the winch control valve. A relief valve between the hoist in line and system return protects the winch motor case shaft seal from high pressure.
3. When the HOIST switch is released to OFF, the winch control shutoff valve and the winch control valve circuits open. The winch control valve and shutoff valve return to the deenergized position. This stops fluid flow to the winch motor, to the brake release line, and the winch control valve. The winch control shutoff valve then directs fluid from the brake release line to the utility hydraulic system return line and the spring-loaded brake is applied automatically.
4. Rotating the HOIST switch to IN closes the contacts that complete the winch control shutoff valve solenoid circuit. It also moves the wiper of the rotary switch into contact with the IN portion of the switch. Current flows through the wiper arm to the IN solenoid of the winch control valve, through the overload limit and in-limit switches on the winch, and the cable cutter plug. The IN solenoid positions the winch control valve to direct fluid through the C2 port of the valve, to the IN port of the winch motor. The pressurized fluid operates the hydraulic motor to reel in the cable. The fluid returns to the system through the OUT port of the winch motor, the pressure reducer, and the return port of the winch control valve.
5. When the CABLE CUTTER switch on either the hoist control panel or the operator's grip is ON, power from the **28-volt dc** bus is connected to the cable cutter cartridge. In this condition, operation of the cable cutter from either the cockpit or cabin is independent of the HOIST MASTER switch.
6. Limit switches prevent winch overloading, stop winch OUT operation when the cable is extended **150 feet**, and stop winch IN operation when the cable is extended **28-1/2 feet** in the rescue mode or extended **3 feet** in the cargo mode. An overload limit switch opens the circuit when the load on the cable exceeds **3,100 to 3,200 pounds** when the winch is operated in the reel-in direction.



7. A shifting lever on the winch controls a two-speed gear train, labeled RESCUE (fast) and CARGO (slow). With the lever at RESCUE, the cable cutter must be plugged into the overhead CABLE CUTTER connector to complete the winch circuit. With the lever at CARGO, the cable cutter must be plugged into the stowage receptacle at sta 95 to complete the circuit. The shifting lever is mechanically linked to three transfer switches. These switches connect voltage to either the rescue or cargo in-limit switch. When the lever is at RESCUE, the rescue (fast) in-limit switch is connected in series with switch 1. With the lever at CARGO, the cargo (slow) in-limit switch is connected in series with switch 2. Switch 3 is a safety device which interrupts the hoist-out circuit when switches 1 and 2 are open. This arrangement prevents the winch from operating in either direction when the gears are not engaged.

8. In case of electrical failure, emergency hydraulic operation of the winch is possible by operating manual override knobs on the winch control shutoff valve and the winch control valve. The knob on the shutoff valve is an on-off valve that allows fluid to flow through the system when it is pushed in. It can be locked in by rotating it. Winch reeling direction (cable in or out) is controlled by rotating the knob on the control valve cw or ccw. When the manual override knobs are used, the cable limit switches are disabled. As a result, care is necessary to prevent reeling the cable too far in or out.

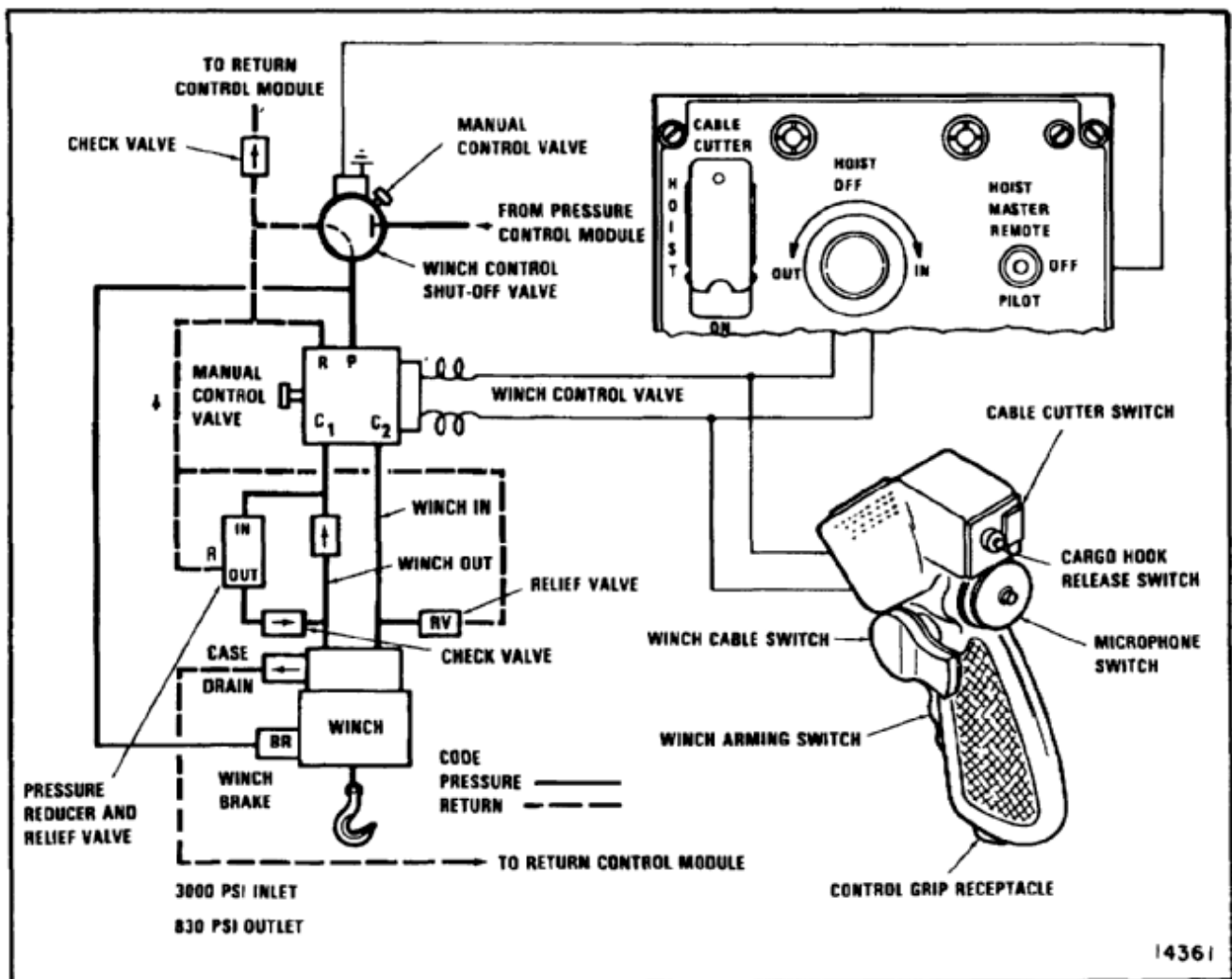

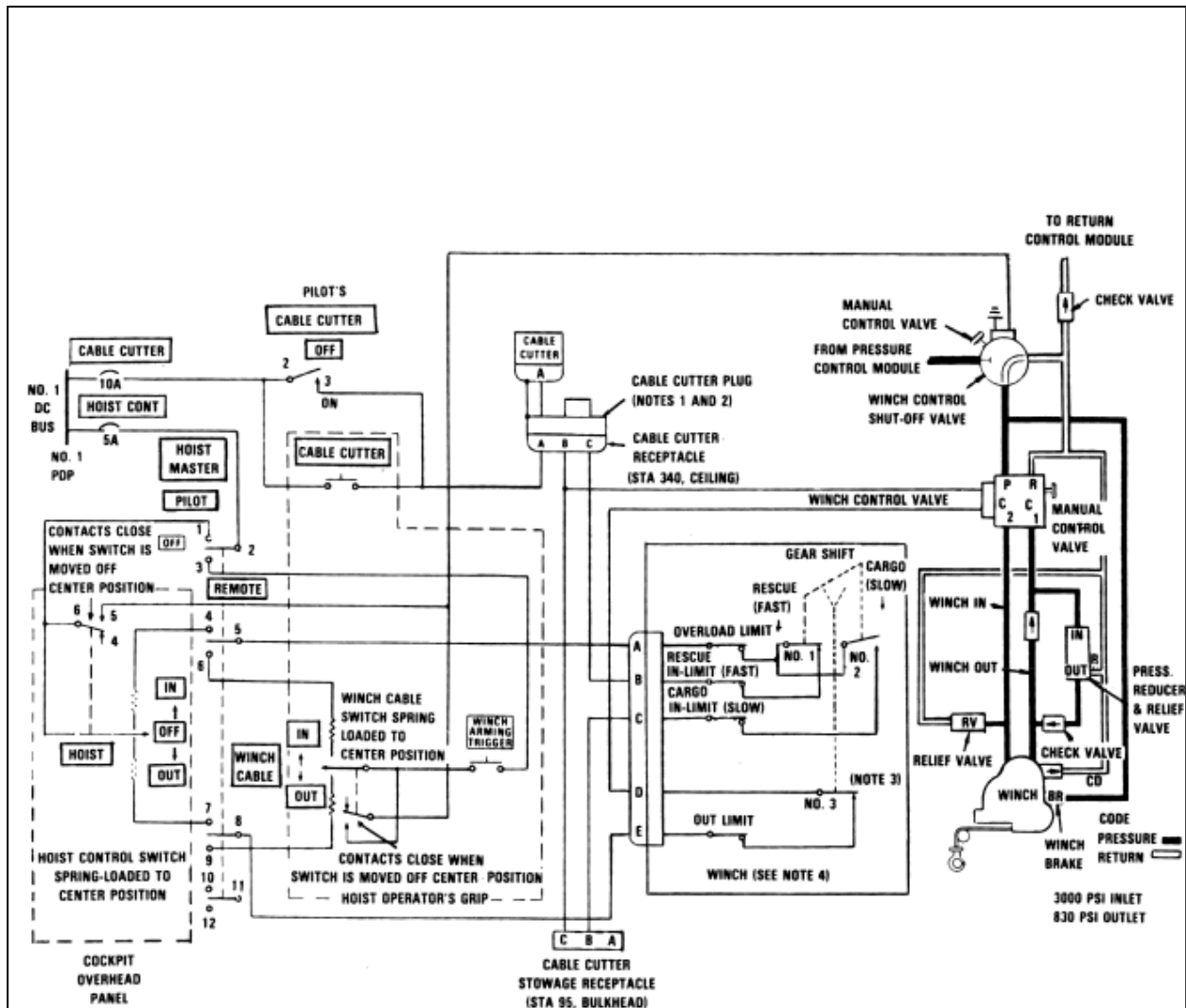

NOTES

1. FOR RESCUE (FAST) OPERATION, CABLE CUTTER PLUG MUST BE PLUGGED INTO CABLE CUTTER RECEPTACLE AND GEAR SHIFT MUST BE IN RESCUE POSITION TO COMPLETE HOIST "IN" CONTROL CIRCUIT.
2. FOR CARGO (SLOW) OPERATION, CABLE CUTTER PLUG MUST BE PLUGGED INTO STOWAGE RECEPTACLE AND GEAR SHIFT MUST BE IN CARGO POSITION TO COMPLETE WINCH "IN" CONTROL CIRCUIT.
3. SWITCH NO. 3 IS OPEN WHEN SWITCH NO. 1 AND SWITCH NO. 2 ARE OPEN SWITCH NO. 3 IS CLOSED WHEN SWITCH NO. 1 OR SWITCH NO. 2 IS CLOSED. THIS ARRANGEMENT PREVENTS WINCH OPERATION WHEN THE GEARS ARE NOT ENGAGED.
4. THESE SWITCHES ARE LOCATED ON THE WINCH.

## **SECTION II CARGO HANDLING SYSTEM**

## INITIAL SETUP

**Applicable Configurations:**

All

**Tools:**

Aircraft Mechanic's Tool Kit, NSN 5180-00-323-4692

**Materials:**

Cloths (E135)  
 Dry Cleaning Solvent (E162)  
 Gloves (E186)  
 Gloves, Wire Handling (E185)

**Personal Required:**

Medium Helicopter Repairer (2)

**References:**

Task 14-10  
 Task 14-11  
 TM 1-1500-204-23  
 TM 55-1520-240-T

**Equipment Condition:**

Battery Connected (Task 1-39)  
 Electrical Power On  
 Hydraulic Power On

**General Safety Instructions:****WARNING**

Wear wire handling gloves while handling cable. Broken wires can injure hands.

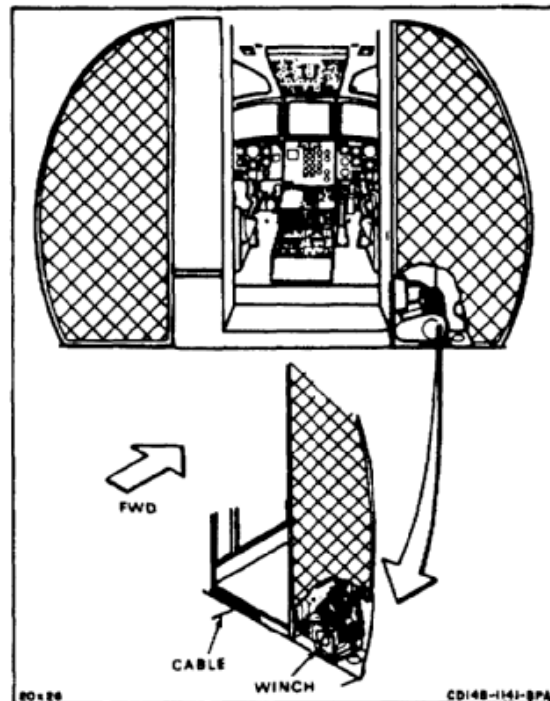

**14-2 CLEAN AND INSPECT WINCH CABLE (Continued)**

14-2

1. Reel out cable (1) (TM 55-1520-240-T). Have helper keep slight pull on cable as cable reels out.
2. Shut down electrical and hydraulic power.

**WARNING**

Dry cleaning solvent (E162) is flammable and toxic. It can irritate skin and cause burns. Use only in well-ventilated area away from heat and open flame. In case of contact, immediately flush skin or eyes with water for at least **15 minutes**. Get medical attention for eyes.

3. Wet cloth (E135) with solvent (E162) and wipe cable (1) clean. Wear gloves (E186).
4. If any of the following conditions are found, have the cable replaced (Tasks 14-10 and 14-11).

**NOTE**

A strand is seven wires twisted together. A cable has 19 strands.

- a. Check cable (1) for broken strands by passing clean dry cloth (E135) along cable. (Refer to TM 1-1500-204-23.)
  - b. Check cable (1). There shall be no bends, kinks, corrosion, or crushed wires. Inspect for **20 feet** of red paint on both ends of cable.
  - c. Check outer wires for wear. If wear on outer wires is **40 to 50 percent**, replace cable (TM 1-1500-204-23).
  - d. Check cable ball end (2). Ball end shall not be loose.
5. Apply electrical and hydraulic power.
  6. Reel in cable (1) (TM 55-1520-240-T). Have helper keep slight drag on cable as cable is reeled in.
  7. Shut down electrical and hydraulic power.

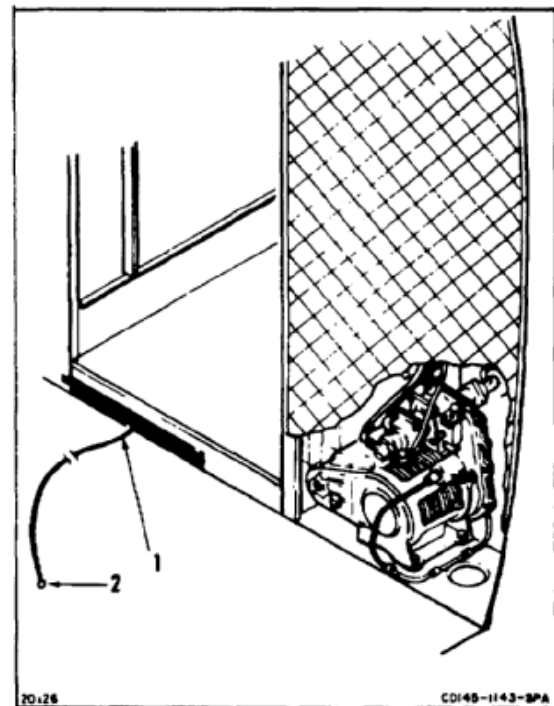
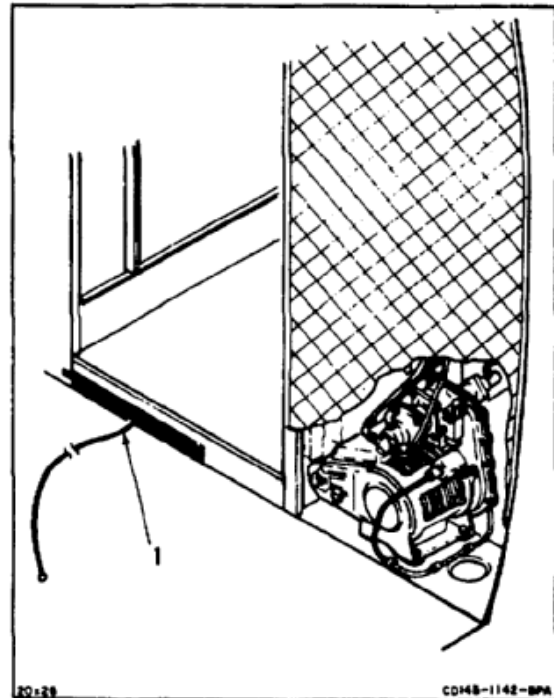
**FOLLOW-ON MAINTENANCE:**

None

END OF TASK

## INITIAL SETUP

**Applicable Configurations:**

All

**Tools:**

Aircraft Mechanic Tool Kit, NSN 5180-00-323-4692

**Materials:**

Lockwire (E231)  
 Marking Pencil (E271)  
 Sealant (E330)  
 Strap (E374)  
 Gloves, Wire Handling (E185)

**Personnel Required:**

Medium Helicopter Repairer (2)  
 Inspector

**References:**

TM 55-1520-240-T

**Equipment Condition:**

Battery Connected (Task 1-39)  
 Heater Compartment Acoustic Blanket Removed  
 (Task 2-208)  
 Stowage Container Removed (Task 14-19)  
 Electrical Power On  
 Hydraulic Power On

**General Safety Instructions:****WARNING**

Proper adjustment of three limit switches is needed for safe operation of winch. Adjust switches very carefully.

**WARNING**

Wear wire handling gloves while handling cable. Broken wires can injure hands.

**WARNING**

Sealant (E330) may irritate skin and cause burns. Avoid contact with skin, eyes, and clothing. In case of contact, immediately flush skin or eyes with water for at least **15 minutes**. Get medical attention for eyes.

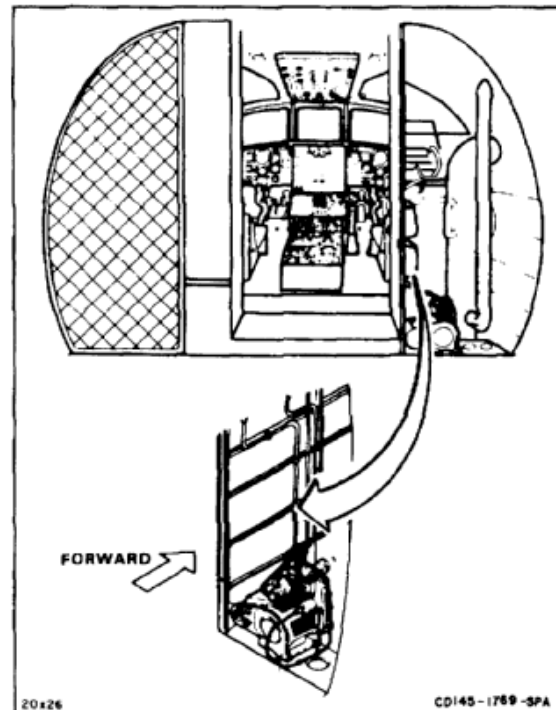

**REMOVE WINCH HOUSING COVER****NOTE**

It is not necessary to remove cover to adjust out-limit switch.

1. Remove lockwire. Remove six screws (1) and washers (2).
2. Lift cover (3) just enough to reach spring (4). Detach spring from underside of cover at bracket (5).
3. Remove cover (3).
4. Cut tie wrap and remove spring (4) from wire bundle (6).

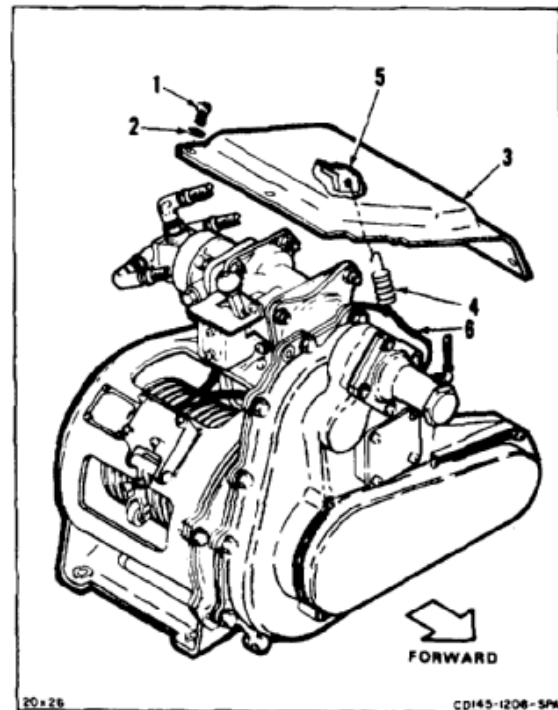
**ADJUST OUT-LIMIT SWITCH**

5. Set shift lever (7) to RESCUE.
6. Have helper keep slight pull on cable (8) as cable reels out. Helper must wear gloves (E185).
7. Reel out cable (8) until only **2-1/2 wraps** are left on drum (9) (TM 55-1520-240-T).
8. Loosen nut (10). Turn screw (11) in or out of lever (12) until it clicks.
9. Apply light coat of sealant (E330) to thread of screw (11). Tighten nut (10) to lock screw in place.

**INSPECT**

10. If no other switches need to be adjusted, go to step 42.

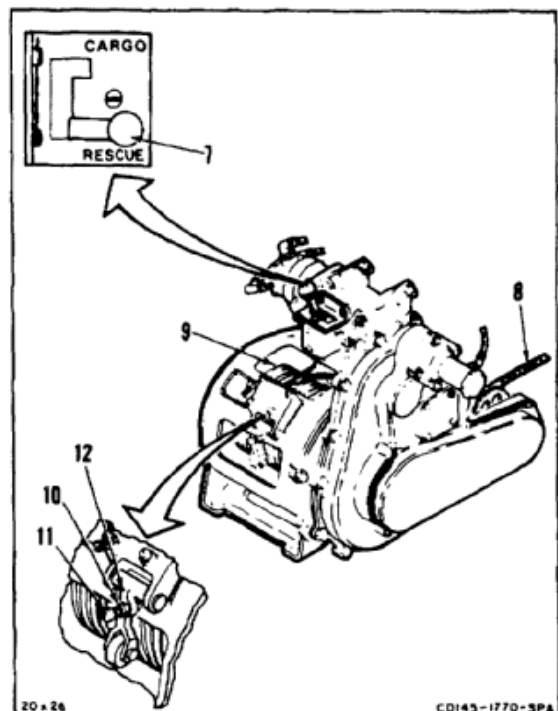

**ADJUST RESCUE MODE IN-LIMIT SWITCH**

11. Set shift lever (7) to RESCUE.
12. Have helper keep slight pull on cable (8) as cable reels out. Helper must wear gloves (E185).
13. Reel out **30 feet** of cable (8) (TM 55-1520-240-T).
14. Mark cable (8) **28-1/2 feet** from ball end (13). Use marking pencil (E271).

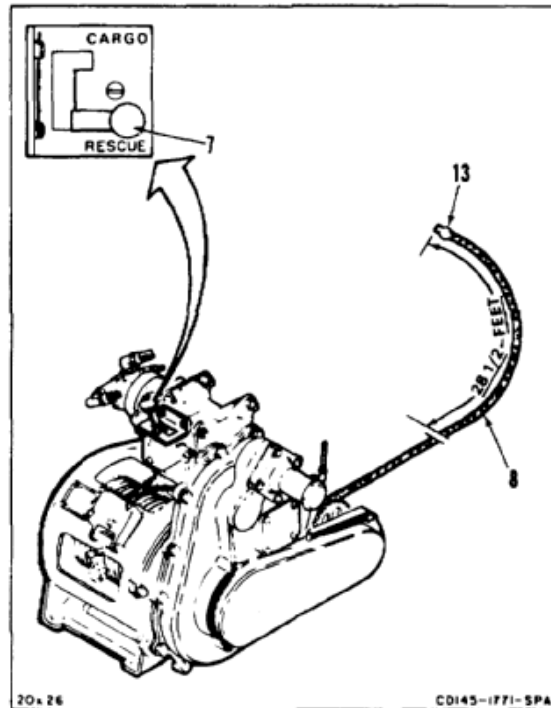

15. Have helper keep slight pull on cable (8) as cable reels in. Helper must wear gloves (E185).
16. Reel in cable (3) until mark just enters levelwind rollers (14).

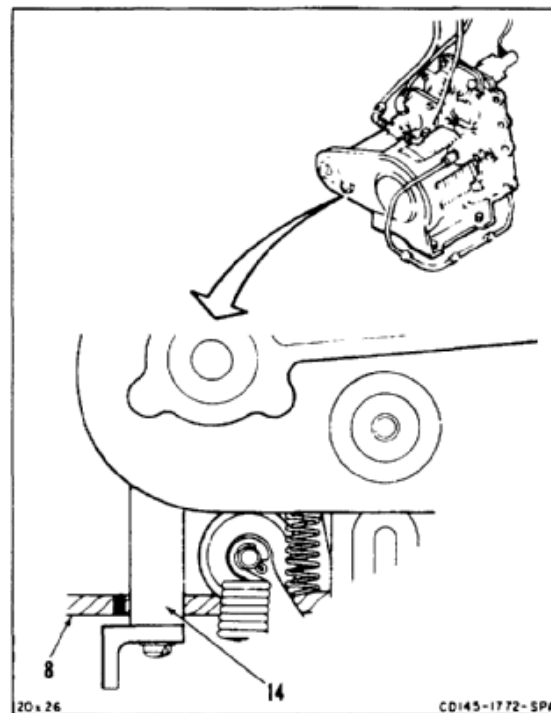



**14-3 ADJUST WINCH LIMIT SWITCHES (Continued)**

14-3

17. Remove four bolts (15) and washers (16). Move winch (17) enough to gain access to switch (18).
18. Loosen two screws (19). Position switch (18) in slots of switch bracket (20) so that it is actuated by striker bracket (21).
19. Apply light coat of sealant (E330) to thread of screws (19). Tighten screws.
20. Deleted.

**INSPECT**

21. If no other switches need adjusting, position winch (17) and install four bolts (15) and washers (16). Go to step 31.

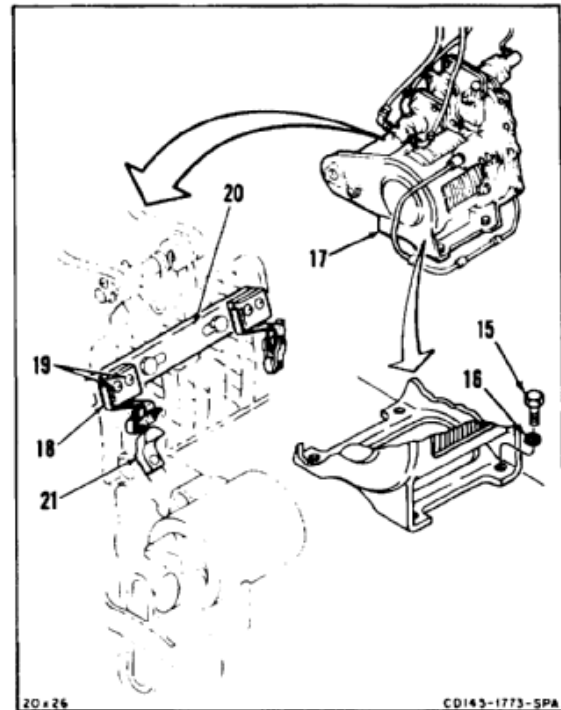
**ADJUST CARGO MODE IN-LIMIT SWITCH**

22. Set shift lever (7) to CARGO.
23. Have helper keep slight pull on cable (8) as it reels out. Helper must wear gloves (E185).
24. Reel out **5 feet** of cable (8) (TM 55-1520-240-T).
25. Mark cable (8) **36 inches** from ball end (13). Use marking pencil (E271).

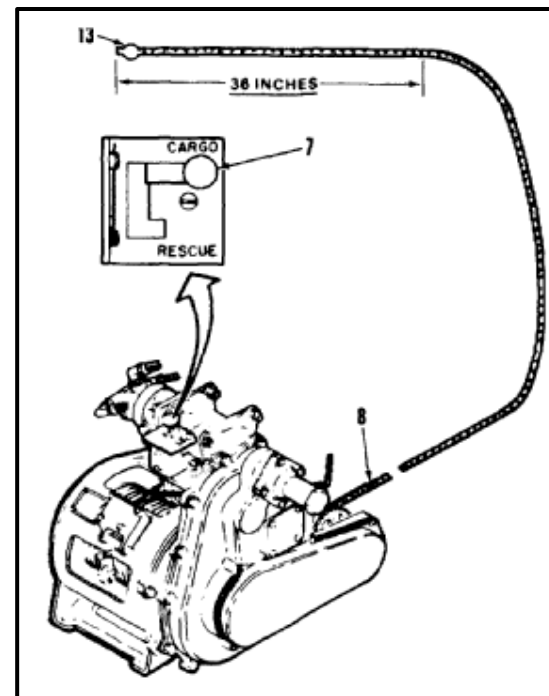

26. Have helper keep slight pull on cable (8) as cable reels in. Helper must wear gloves (E185).
27. Reel in cable (8) until mark just enters levelwind rollers (14).

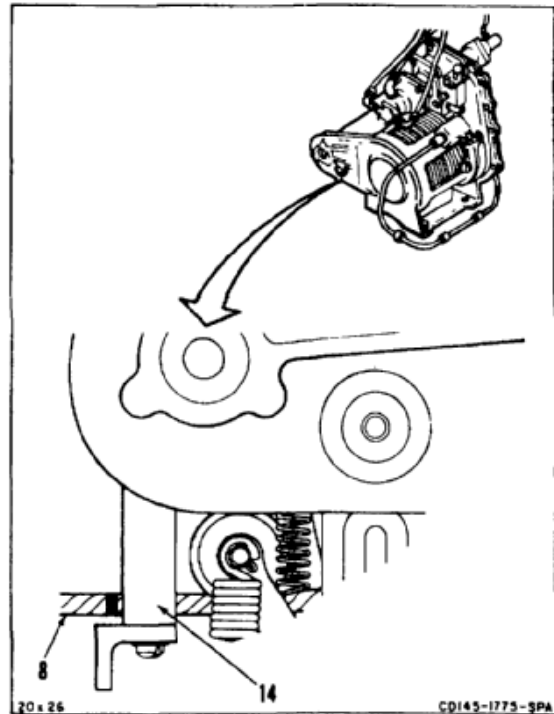

28. Deleted.
29. Loosen two screws (22). Position switch (23) in slots of switch bracket (20) so that it is actuated by striker bracket (21).
30. Apply light coat of sealant (E330) to thread of screws (22). Tighten screws.

**INSPECT**

31. Test winch (17) (TM 55-1520-240-T).
32. Turn off electrical and hydraulic power.

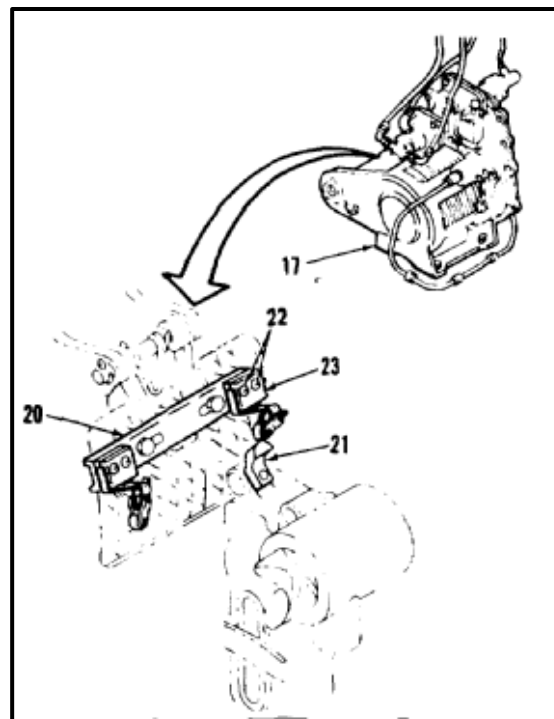

**ADJUST OVERLOAD LIMIT SWITCH**

33. Set switch lever (7) to CARGO.
34. Have helper keep slight pull on cable (8) as cable reels out. Helper must wear gloves (E185).
35. Reel out cable (8) until it is fully extended (TM 55-1520-240-T).
36. Attach **3100 to 3300 pound** drag load to cable (8).
37. With load attached, reel in cable (8) until two layers of cable are wrapped on drum (9).

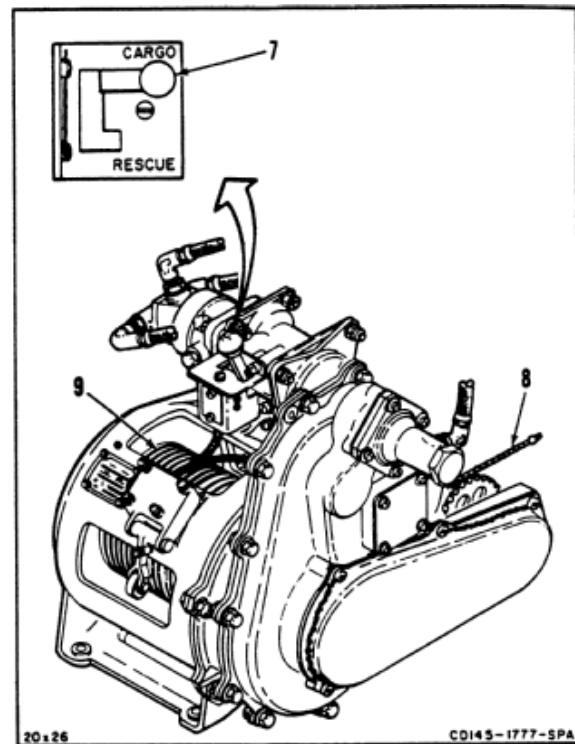

38. Repeat step 17.
39. Loosen two nuts (24). Position switch (25) in slots of cable tension bracket (26) so that it is actuated by load on second layer of cable (8).
40. Apply light coat of sealant (E330) to thread of screws (27). Tighten nuts (24).

**INSPECT**

41. Repeat step 20.
42. Test winch (17) (TM 55-1520-240-T).
43. Turn off electrical and hydraulic power.

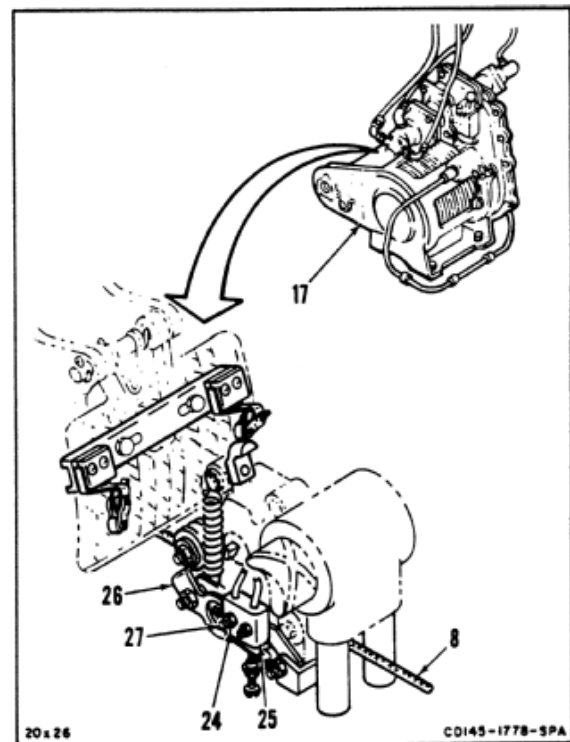

**INSTALL WINCH HOUSING COVER**

- 44. Deleted.
- 45. Connect lower end of spring (4) to wire bundle (6). Use strap (E374).
- 46. Position cover (3). Lift cover enough to attach spring (4) to underside of cover at bracket (5). Lower cover.
- 47. Secure cover (3) to housing with six screws (1) and washers (2).

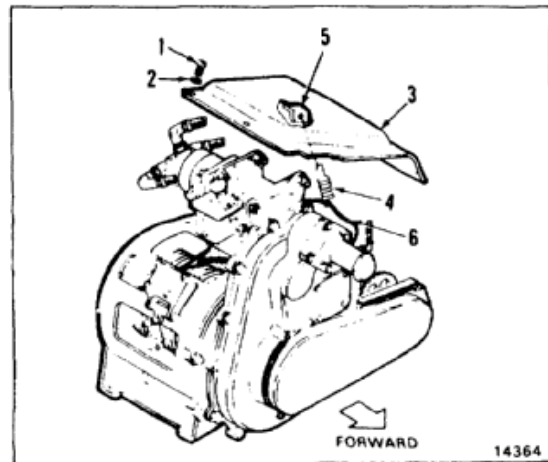

- 48. Lockwire screws (1) together in pairs. Use lockwire (E231).

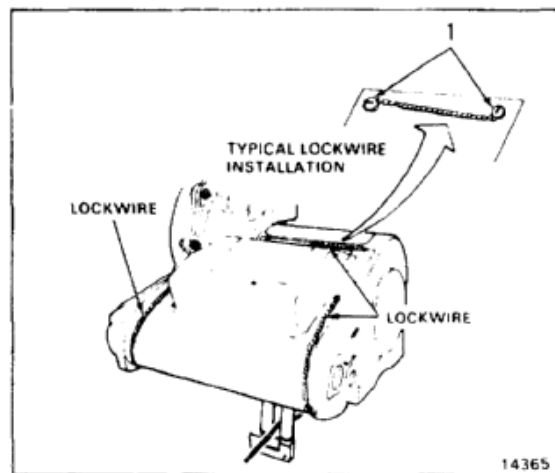

- 49. Position winch (17). Install four bolts (15) and washers (16).

**INSPECT**

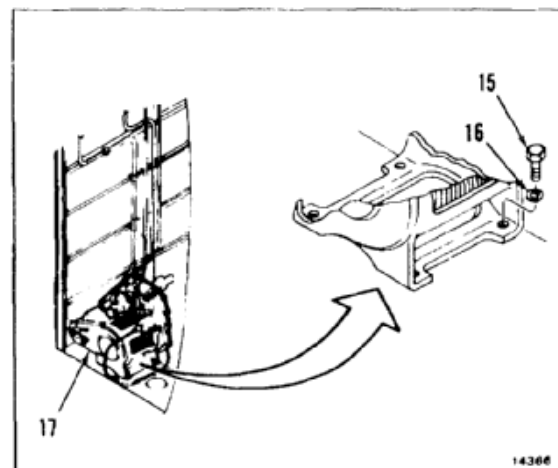

**FOLLOW-ON MAINTENANCE:**

Install stowage container (Task 14-20).

END OF TASK

**14-3.1 REPLACE WINCH LIMIT SWITCHES**

14-3.1

**INITIAL SETUP****Applicable Configurations:**

All

**Tools:**

Aircraft Mechanic's Tool Kit, NSN 51 80-00-323-4692

**Materials:**

Lockwire (E231)

Sealant (E330)

Strap (E374)

Gloves (E186)

**Personnel Required:**

Medium Helicopter Repairer (2)

Inspector

**References:**

None

**Equipment Condition:**

Battery Disconnected (Task 1-39)

Electrical Power Off

Hydraulic Power Off

Heater Compartment Acoustic Blanket Removed  
(Task 2-208)

Stowage Container Removed (Task 14-19)

**General Safety Instructions:****WARNING**

Sealant (E330) may irritate skin and cause burns. Avoid contact with skin, eyes and clothing. In case of contact, immediately flush skin or eyes with water for at least **15 minutes**. Get medical attention for eyes.

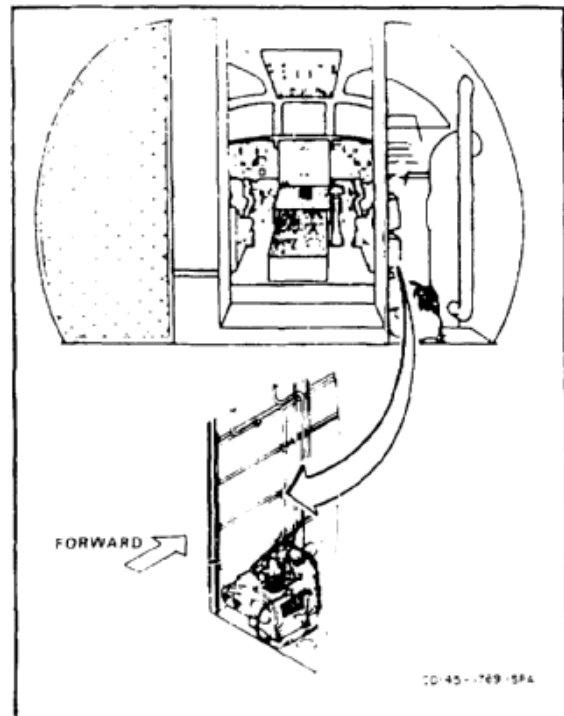

**REMOVE WINCH HOUSING COVER****NOTE**

Procedure is the same to replace out-limit switch and in-limit switch. Out-limit switch is shown here.

1. Remove lockwire. Remove six screws (1) and washers (2).
2. Lift cover (3) just enough to reach spring (4). Detach spring from underside of cover at bracket (5).
3. Remove cover (3).
4. Cut tie wrap and remove spring (4) from wire bundle (6).

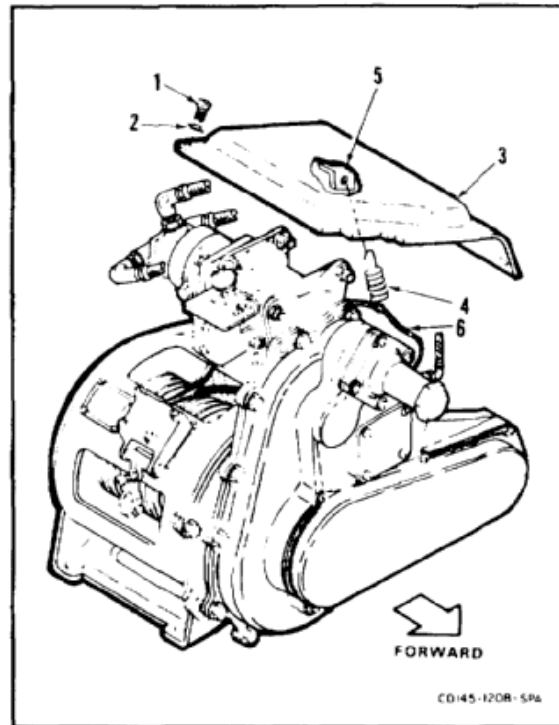

**REMOVE OUT/IN LIMIT SWITCH**

5. Remove four bolts (7) and washers (8). Move winch (9) enough to gain access to switch (10).
6. Remove two screws (11), washers (11.1), switch (10), two adapters (11.2), bracket (11.3), and spacer (11.4) from switch holder (12).

**INSTALL OUT/IN LIMIT SWITCH**

7. Install spacer (11.4), bracket (11.3), two adapters (11.2), and switch (10) in switch holder (12).
8. Position switch (10) in slots of switch holder (12) so that it is actuated by striker bracket (13).
9. Apply light coat of sealant (E330) to thread of screws (11). Wear gloves (E186).
10. Install washers (11.1) and screws (11). Tighten two screws (11).

**INSPECT**

11. If no other switches need replacing, position winch (9). Install four bolts (7) and washers (8). Go to step 19.

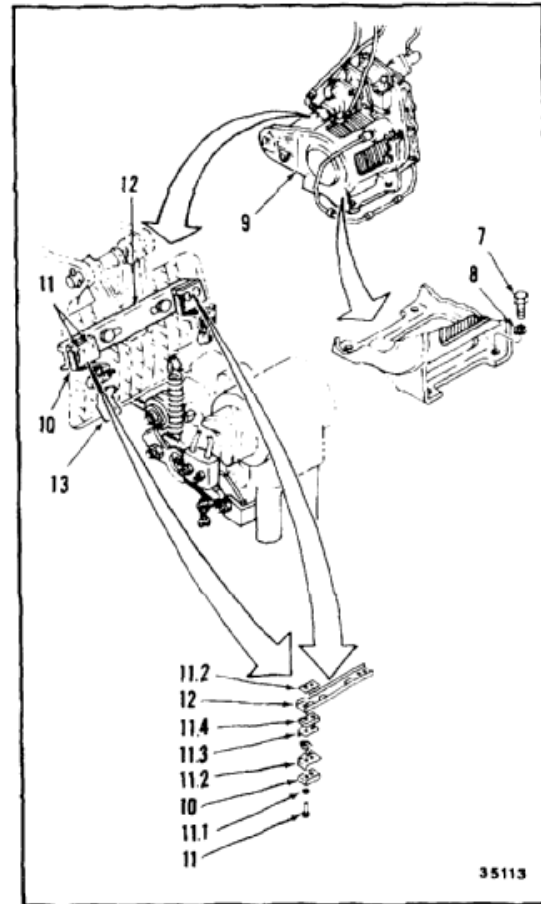

35113

**REMOVE OVERLOAD LIMIT SWITCH**

12. Repeat steps 1 thru 5.
13. Remove two nuts (14).
14. Remove switch (15) from cable tension bracket (16).

**INSTALL OVERLOAD LIMIT SWITCH**

15. Position switch (15) in slots of cable tension bracket (16) so that it is actuated by load on second layer of cable (17).
16. Apply light coat of sealant (E330) to thread of screws (18). Wear gloves (E186).
17. Tighten two nuts (14).

**INSPECT**

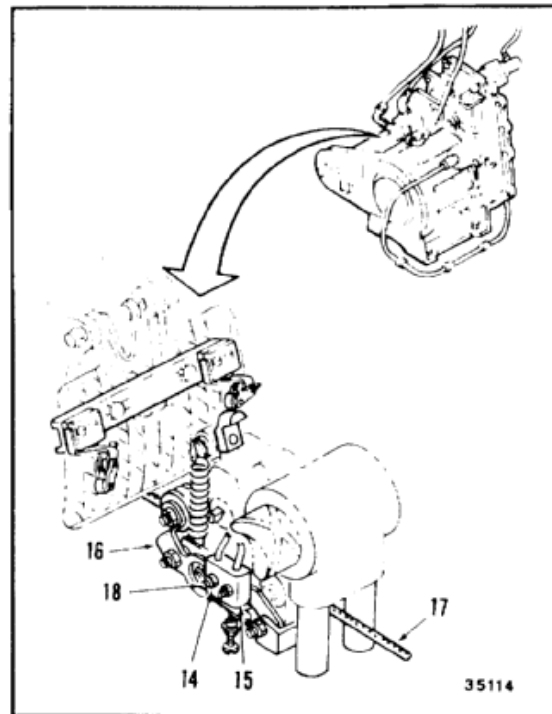

18. Position winch (9). Install four bolts (7) and washers (8).

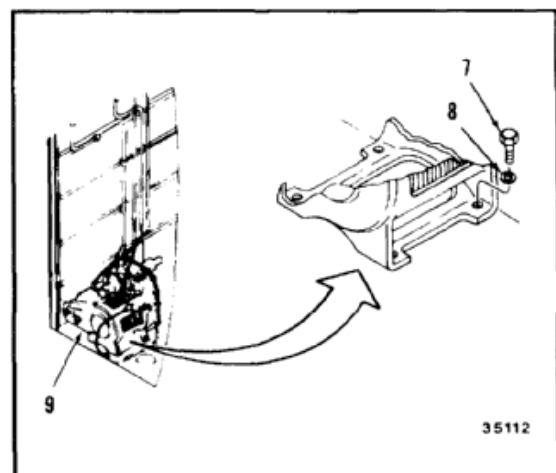



**INSTALL WINCH HOUSING COVER**

19. Connect lower end of spring (4) to wire bundle (6). Use tie wrap (E374).
20. Position cover (3). Lift cover enough to attach spring (4) to underside of cover at bracket (5). Lower cover.
21. Secure cover (3) to housing with six screws (1) and washers (2).

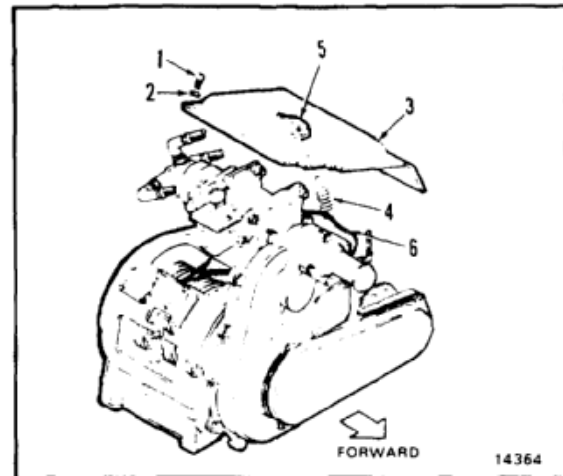

22. Lockwire screws (1) together in pairs. Use lockwire (E231).

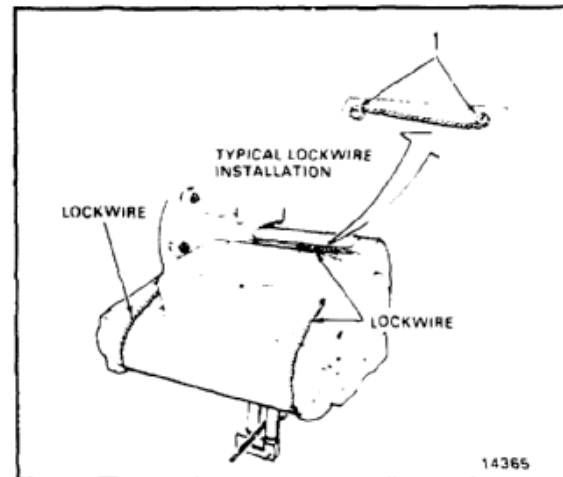
**INSPECT****FOLLOW-ON MAINTENANCE:**

- Perform operational check (TM 55-1520-240-T).
- Install stowage container (Task 14-20).
- Install heater compartment acoustic blanket (Task 2-210).

END OF TASK

## INITIAL SETUP

**Applicable Configurations:**

All

**Tools:**

Aircraft Mechanic's Tool Kit, NSN 5180-00-323-4692  
 Container, Two Quart

**Materials:**

Paper Tags (E264)  
 Cloths (E135)

**Personnel Required:**

Medium Helicopter Repairer (2)

**Equipment Condition:**

Battery Disconnected (Task 1-39)  
 Electrical Power Off  
 Hydraulic Power Off  
 Utility Hydraulic System Depressurized (TM  
 55-1520-240-T)  
 Heater Compartment Acoustic Blanket Removed  
 (Task 2-208)  
 Cockpit Aft Floor Panel Removed (Task 2-83)

**DISCONNECT HOSES AND ELECTRICAL CONNECTOR****WARNING**

Use container to catch fluid as each hose is disconnected. Spilled fluid is a hazard.

1. Tag and disconnect hose (1).
2. Tag and disconnect three hoses (2). Wipe up spilled fluid with cloths (E135).
3. Disconnect electrical connector (3).

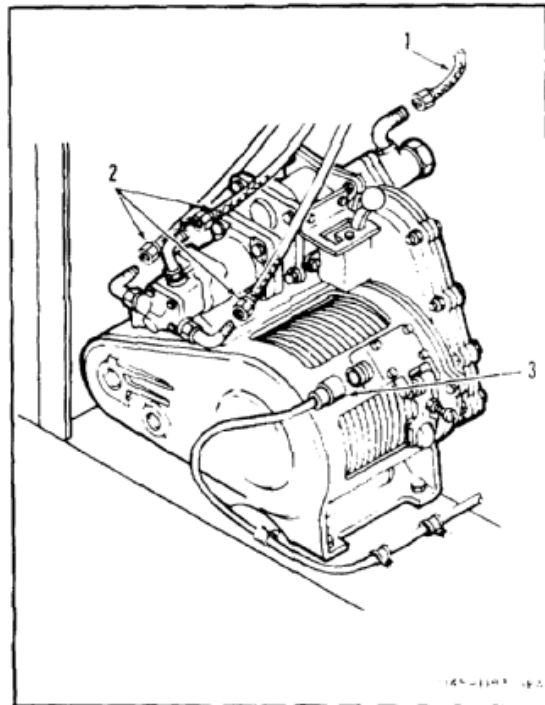
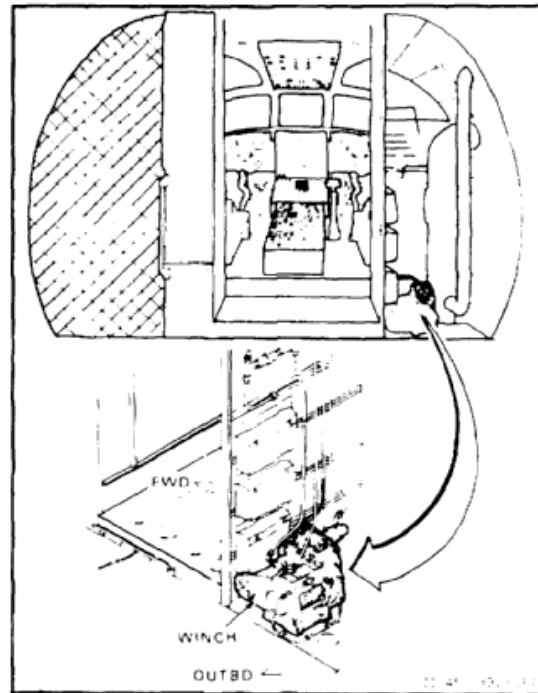

**REMOVE WINCH**

4. Remove three screws (4). Remove cable panel (5).
5. Remove four bolts (6) and washers (7).

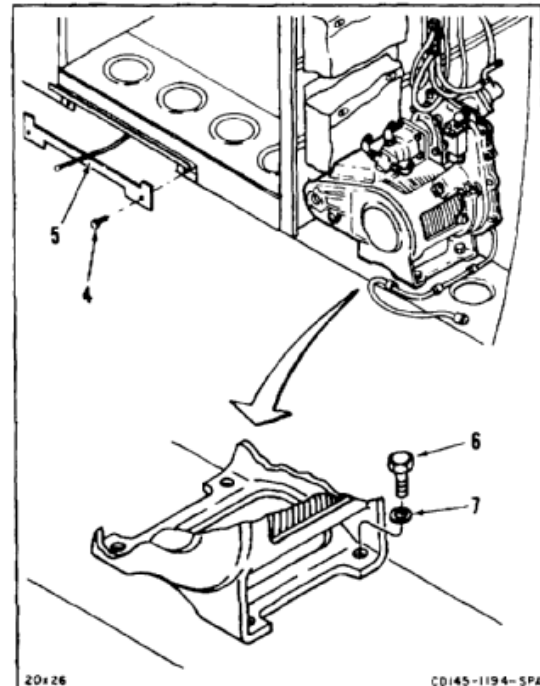

6. Reach under structure (8) and remove nut (9) and washer (10). Remove bolt (11) and washer (12).
7. Move pulley (13) outboard along bracket (14).
8. Slide winch (15) away from structure (8). At same time, have helper pull cable (16) through cable guard (17). Pull cable (16) out from between pulley (13) and bracket (14).

**WARNING**

Winch weighs **56 pounds**. Do not lift winch without help. Personal injury can result.

**CAUTION**

Take care not to damage electrical connector or wiring when removing winch.

9. Secure cable (16) to winch (15). Remove winch from compartment.

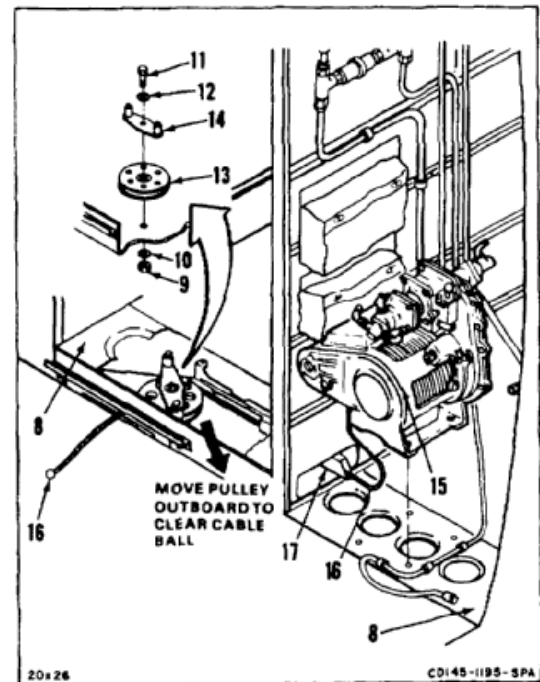

**PARTS REMOVAL**

**NOTE**

Remove parts only if replacement winch will be installed. Note position of elbows for reinstallation.

10. Remove two elbows (18) by loosening attaching nuts (19). Remove two packings (20) and washers (21).

11. Remove two elbows (22) by loosening attaching nuts (23). Remove two packings (24) and washers (25).

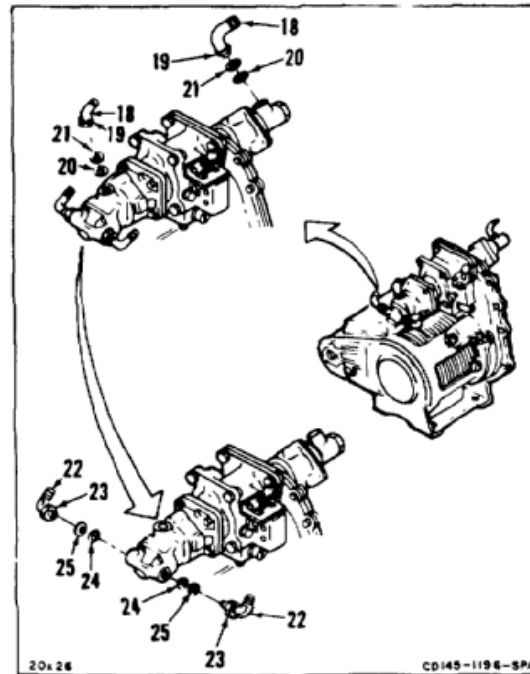

12. Remove two nuts (26), four washers (27), and two screws (28). Remove cable guard guide (29).

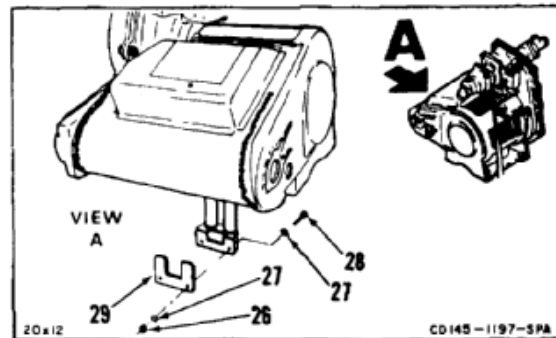

**FOLLOW-ON MAINTENANCE:**

None

END OF TASK

**14-5 REMOVE CLUTCH CHAIN AND ROLLER CHAINS (AVIM)**

14-5

**INITIAL SETUP**

**Applicable Configurations:**

All

**Tools:**

Aircraft Mechanic's Tool Kit, NSN 51 80-00-323-4692

**Materials:**

None

**Personnel Required:**

Medium Helicopter Repairer

**References:**

Task 14-10

**Equipment Condition:**

Off Helicopter Task

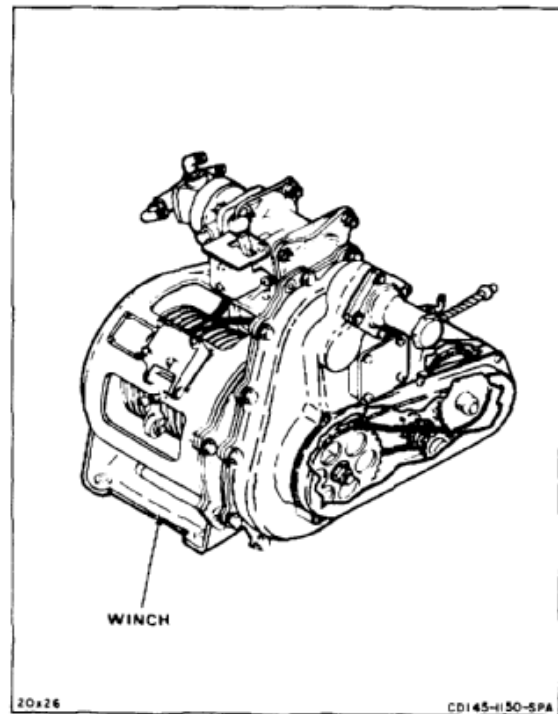

1. Remove lockwire. Remove six screws (1) and washers (2).
2. Lift cover (3). Cut strap (4) from wire bundle (5).
3. Remove cover (3).
4. Disconnect spring (6) from bracket (7).

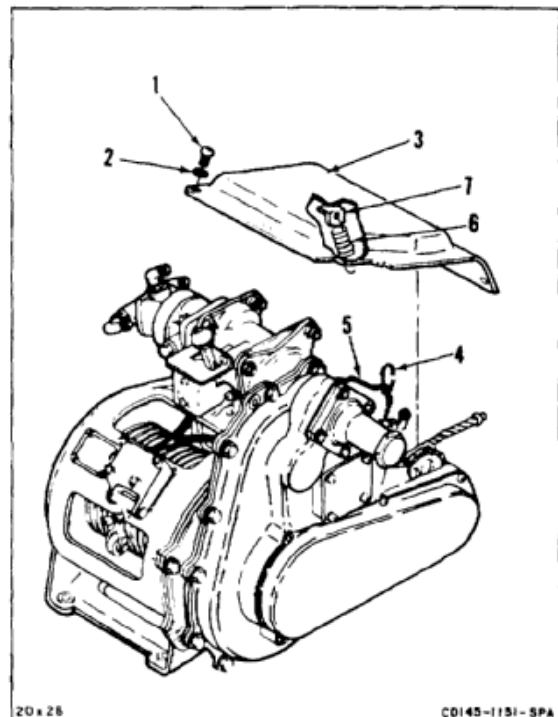

5. Remove spring lock (8) from clutch chain (9). Remove chain.
6. Remove lockwire. Remove six screws (10) and washers (11). Remove cover (12).
7. Remove spring lock (3) from roller chain (13). Remove chain.
8. Remove spring lock (8) from roller chain (14). Remove chain.
9. Remove cable (15) (Task 14-10).

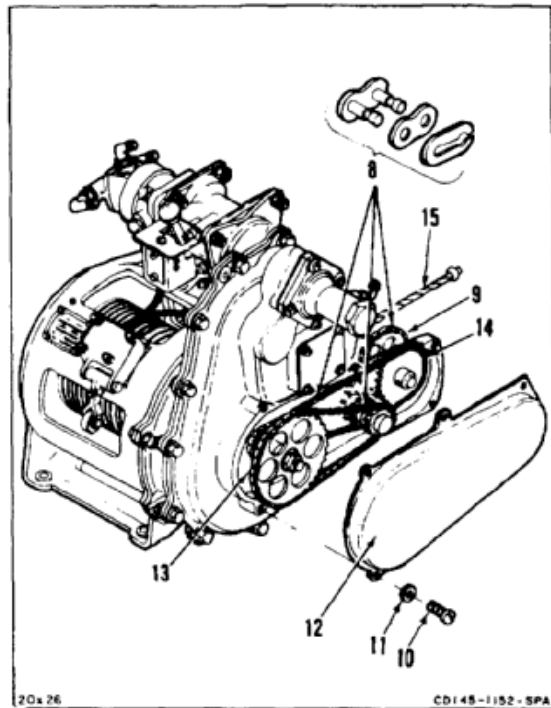
**FOLLOW-ON MAINTENANCE:**

None

END OF TASK

## INITIAL SETUP

**Applicable Configurations:**

All

**Tools:**

Aircraft Mechanic's Tool Kit, NSN 51 80-00-323-4692  
Source of Compressed Air

**Materials:**

Brush (E85)  
Dry Cleaning Solvent (E162)  
Gloves (E186)

**Personnel Required:**

Medium Helicopter Repairer  
Inspector

**Equipment Condition:**

Off Helicopter Task  
Clutch Chain and Roller Chains Removed (Task 14-5)

**WARNING**

Dry cleaning solvent (E162) is flammable and toxic. It can irritate skin and cause burns. Use only in well-ventilated area away from heat and open flame. In case of contact, immediately flush skin or eyes with water for at least **15 minutes**. Get medical attention for eyes.

**WARNING**

Do not use more than **30 psi** compressed air for cleaning purposes. Debris propelled under pressure can cause injury to eyes. Use source of compressed air under **30 psi** and eye protection to prevent injury to personnel.

1. Dip brush (E85) in solvent (E162). Clean chains (1), covers (2), and sprockets (3). Dry parts with low pressure dry air. Use goggles for eyes and wear gloves (E186).
2. Check sprockets (3). There shall be no burrs, nicks, or broken teeth.
3. Check chains (1). There shall be no broken or worn links or rollers.

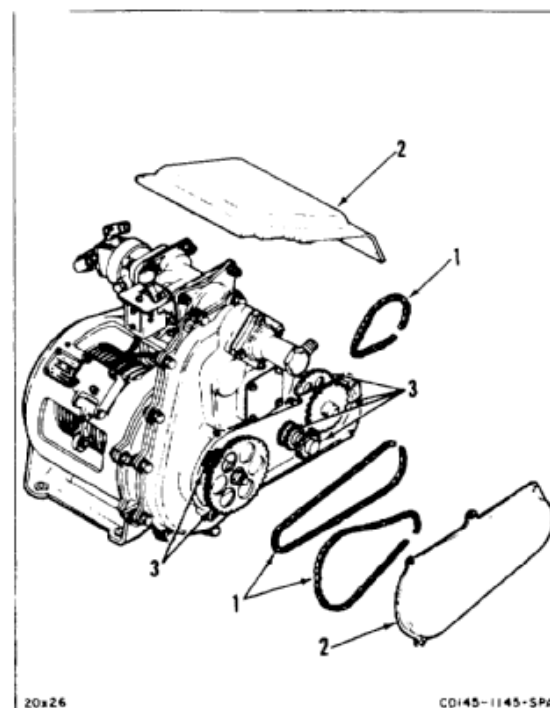
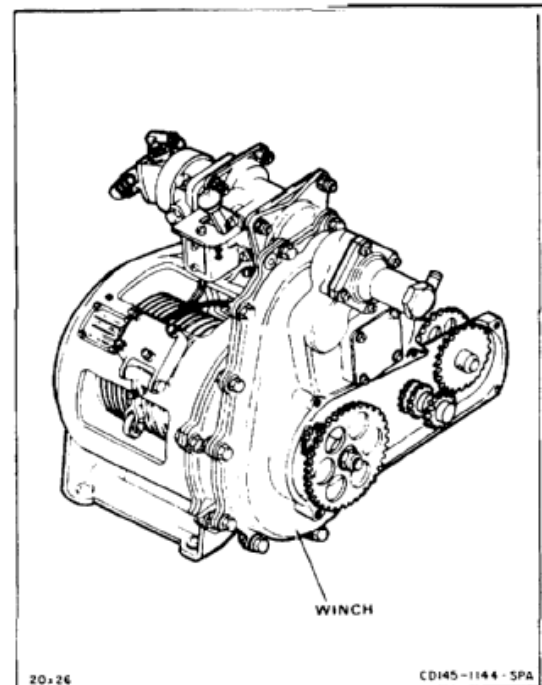

4. Check spring locks (4). There shall be no cracks, bends, or poor locking action.
5. Check covers (2). There shall be no cracks, dents, or out-of-round holes.

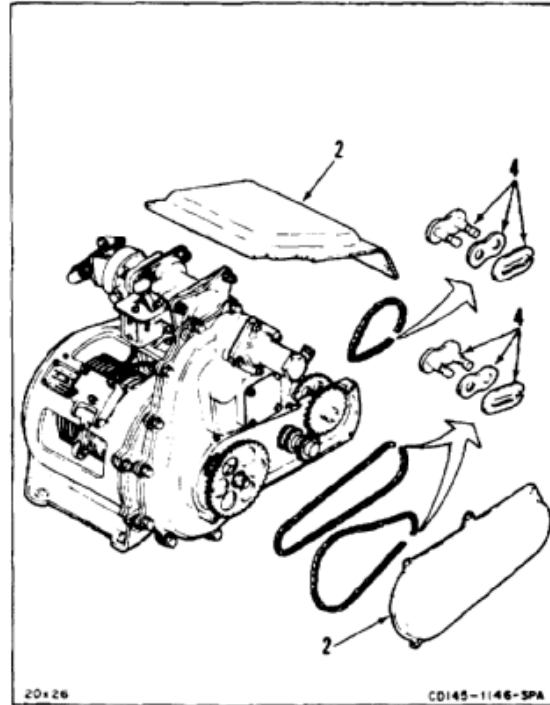
***FOLLOW-ON MAINTENANCE:***

Install clutch chain and roller chains (Task 14-8).

END OF TASK



## INITIAL SETUP

**Applicable Configurations:**

All

**Tools:**

Aircraft Mechanic's Tool Kit, NSN 51 80-00-323-4692

**Materials:**

None

**Personnel Required:**

Medium Helicopter Repairer

**Equipment Condition:**

Off Helicopter Task

Winch Wire Rope (Cable) Removed (Task 14-10)

Clutch Chain and Roller Chains Removed (Task 14-5)

**NOTE**

Dwell position is at far end of levelwind screw, next to chain housing.

1. Turn levelwind screw (1) until pin (2) in levelwind housing (3) lines up in dwell position.



Do not turn drum or levelwind screw after timing is complete. Cable snarl could result.

2. Turn drum (4) until cable socket (5) in drum is straight down. Drum is now timed to levelwind screw (1). Do not move drum or screw until chains are installed.

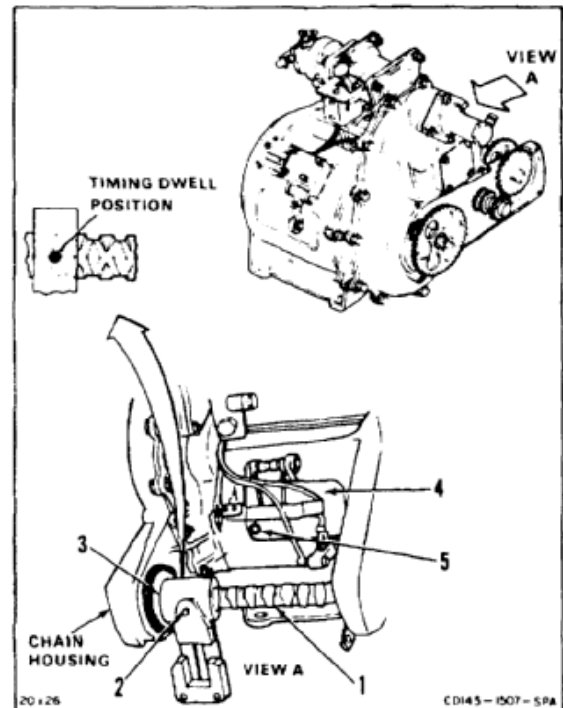
**FOLLOW-ON MAINTENANCE:**

Install clutch chains and roller chains (Task 14-8).

END OF TASK

## INITIAL SETUP

**Applicable Configurations:**

All

**Tools:**

Aircraft Mechanic's Tool Kit, NSN 5180-00-323-4692

**Materials:**

Grease (E190)  
 Lockwire (E231)  
 Tie-Wrap (E374)

**Personnel Required:**

Medium Helicopter Repairer  
 Inspector

**References:**

Task 14-7  
 Task 14-11  
 TM 55-1520-240-23P

1. Apply light coat of grease (E190) on clutch chain (1), roller chain (2), and roller chain (3). Put light coat of grease (E190) on sprockets (4).
2. Time winch cable drum and levelwind mechanism (Task 14-7).



Do not move cable drum or levelwind screw when installing chains. Levelwind timing could change, which could snarl the cable.

3. Install roller chain (2). Install spring lock (5).
4. Install roller chain (3). Install spring lock (5).
5. Install clutch chain (1). Install spring lock (5).
6. Position cover (6). Install six screws (7) and washers (8). Lockwire screws with lockwire (E231).

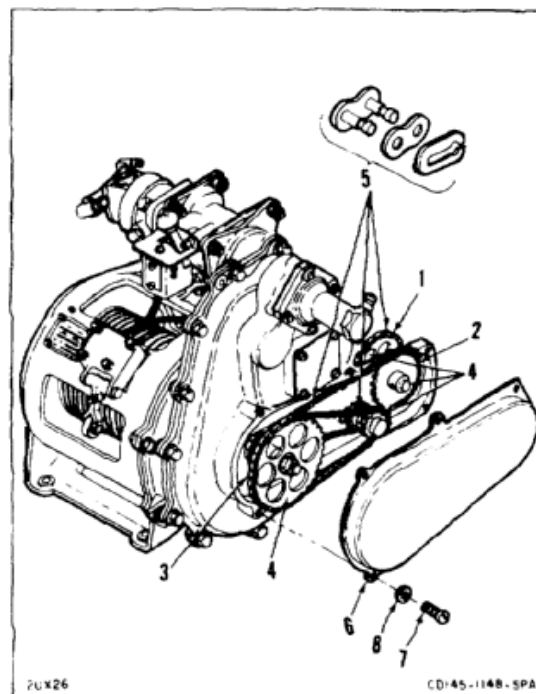
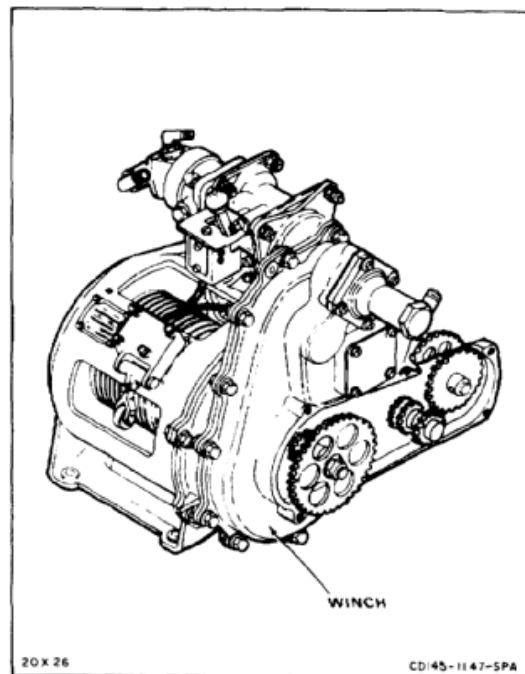

**14-8 INSTALL CLUTCH CHAIN AND ROLLER CHAINS (AVIM) (Continued)**

14-8

7. Install winch cable (Task 14-11).
8. Connect one end of spring (9) to wire bundle (10). Use tie-wrap (E374).
9. Attach other end of spring (9) to bracket (11).
10. Position cover (12). Install six screws (13) and washers (14). Lockwire screws using lockwire (E231).

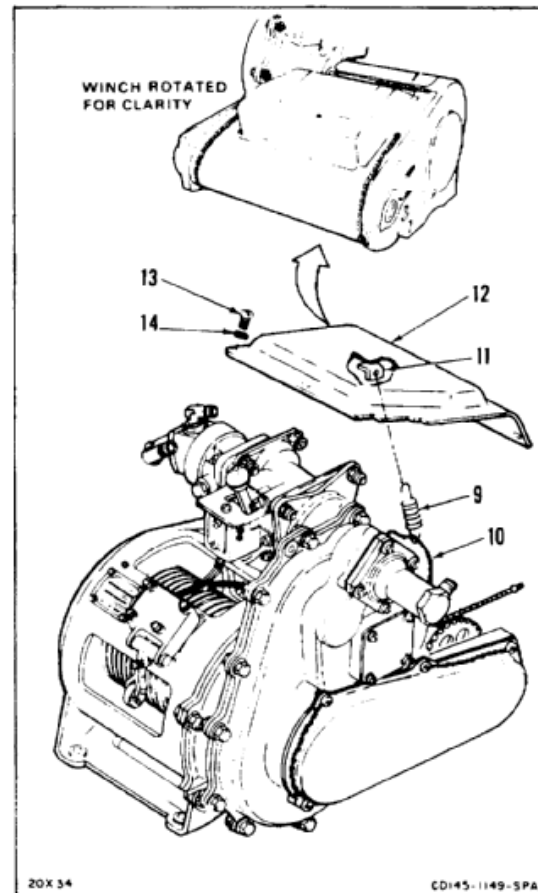
**INSPECT****FOLLOW-ON MAINTENANCE:**

None

END OF TASK

INITIAL SETUP

**Applicable Configurations:**

All

**Tools:**

Aircraft Mechanic's Tool Kit, NSN 5180-00-323-4692

**Materials:**

Cloths (E135)  
Hydraulic Fluid (E197)

**Parts:**

Preformed Packings  
Nonmetallic Washers

**Personnel Required:**

Medium Helicopter Repairer (2)  
Inspector

**References:**

TM 55-1520-240-23P

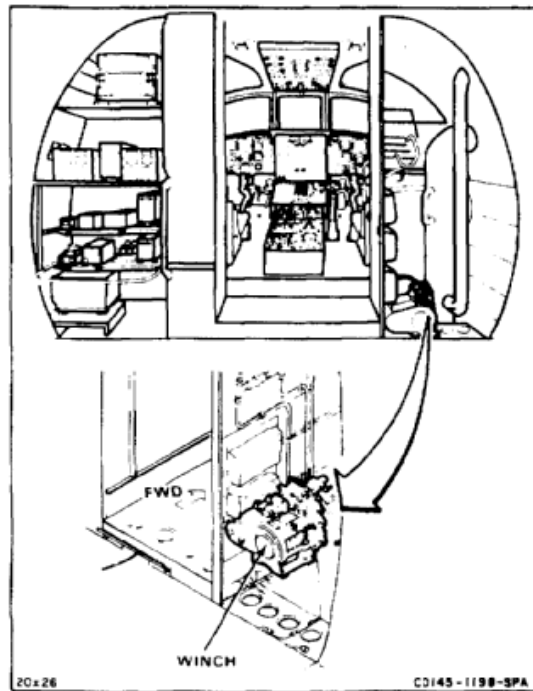

**PARTS INSTALLATION**

**NOTE**

Install parts on a replacement winch only as required.

1. Apply light coat of hydraulic fluid (E197) to two new washers (1) and packings (2). Coat thread of two elbows (3).
2. Install one washer (1) and packing (2) on each elbow (3).
3. Install elbows (3) with nuts (4) attached. Point elbows straight back, as shown, and tighten nuts.

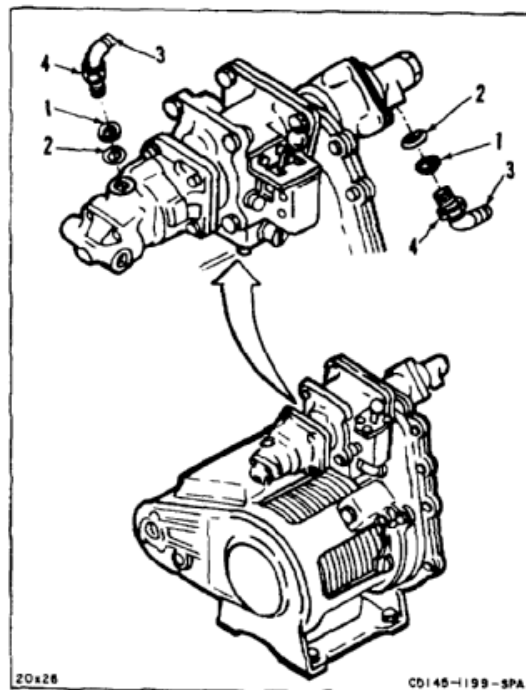

**14-9 INSTALL WINCH (Continued)**

4. Apply light coat of hydraulic fluid (E197) to two new washers (4) and packings (5). Coat thread of two elbows (6).
5. Install one washer (4) and packing (5) on each elbow (6).
6. Install elbows (6), with nuts (7) attached. Point elbows as shown and tighten nuts.

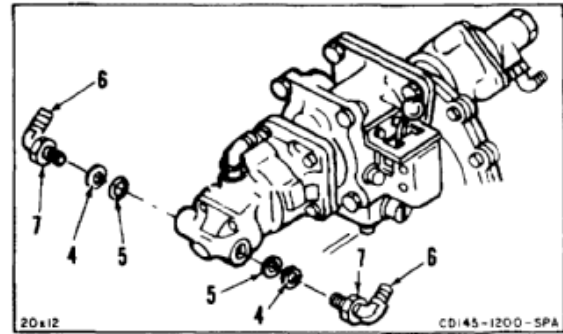

7. Install cable guard guide (8). Secure with two screws (9), four washers (10), and two nuts (11).

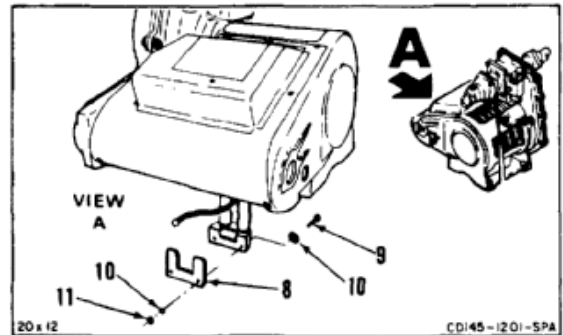

**INSTALL WINCH**

8. Set winch (12) on heater compartment floor. Route cable (13) through cable guard (14).
9. Route cable (13) around pulley (15) and bracket (16). Move pulley outboard along bracket as needed for clearance. Pass cable through slot in bulkhead (17).
10. Align two washers (18) with holes in pulley (15) and bracket (16). Install bolt (19) and washer (20). Install washer (21) and nut (22) by reaching under structure (23).
11. Position winch (12) to fit cable (13) into cable guard (14). Align mounting holes in winch and floor.

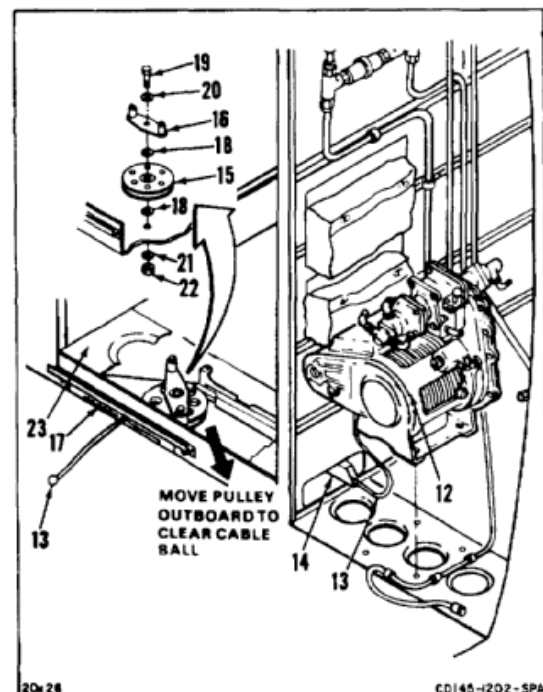

12. Install four bolts (24) and washers (25).
13. Secure panel (26) to bulkhead with two screws (27).

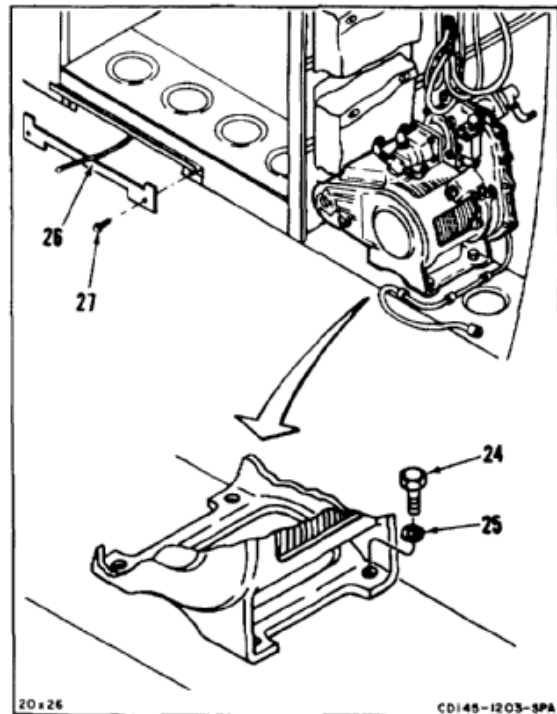

#### **CONNECT HOSES AND ELECTRICAL CONNECTOR**

14. Connect three hoses (28) as follows:
  - a. HOIST UP to IN port.
  - b. HOIST DOWN to OUT port.
  - c. RETURN to CABLE port.
15. Connect hose (29).
16. Connect electrical connector (30).

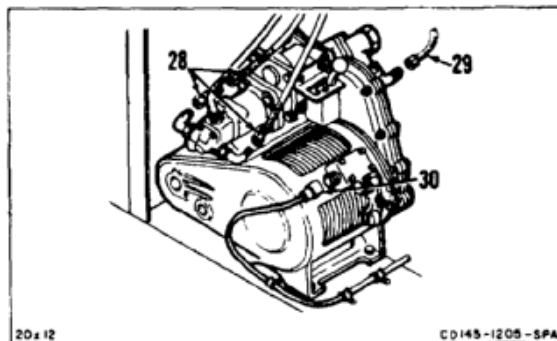

#### **INSPECT**

#### **FOLLOW-ON MAINTENANCE:**

- Install cockpit aft floor panel (Task 2-84).
- Bleed winch hydraulic system (Task 7-333).
- Install heater compartment blanket (Task 2-210).
- Perform operational check (TM 55-1520-240-T).

END OF TASK

**14-10 REMOVE WINCH WIRE ROPE CABLE**

14-10

**INITIAL SETUP****Applicable Configurations:**

All

**Tools:**

Aircraft Mechanic's Tool Kit, NSN 5180-00-323-4692  
 Container, Two Quart  
 Wooden Block, 2 Inch X 4 Inch X 12 Inch

**Materials:**

Cloths (E120)  
 Gloves, Wire Handling (E185)

**Personnel Required:**

Medium Helicopter Repairer (2)

**References:**

TM 55-1520-240-T

**Equipment Condition:**

Battery Connected (Task 1-39)  
 Electrical Power On  
 Hydraulic Power On  
 Acoustic Blanket Removed from Heater Compartment  
 (Task 2-208)  
 Cockpit Aft Floor Panel Removed (Task 2-83)

**General Safety Instructions:****WARNING**

Wear wire handling gloves when removing wire rope (cable). Otherwise, injury to hands can result.

**NOTE**

Keep tension on wire rope when reeling wire rope out. Wire rope will reel out evenly and will not snarl.

1. Have helper keep slight pull on wire rope (1). Helper must wear gloves (E185).

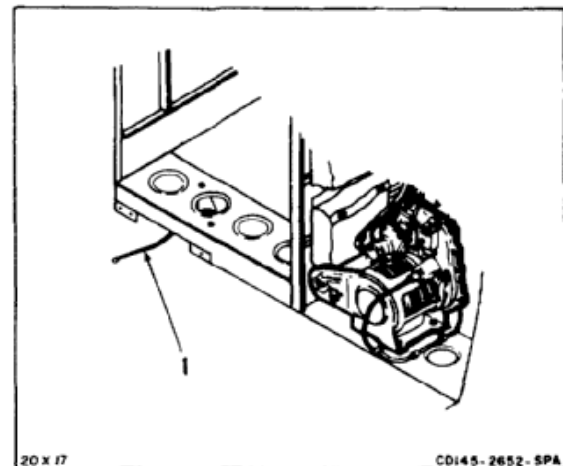
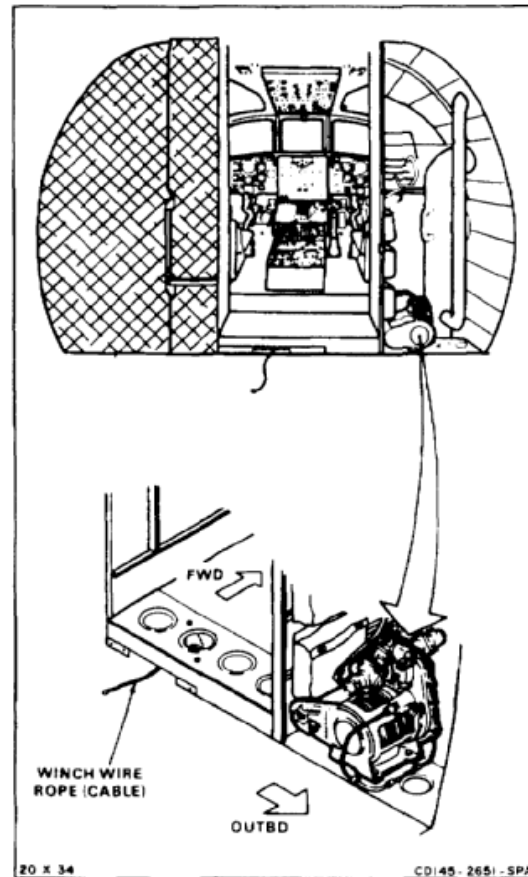

2. Reel out all wire rope (1) (TM 55-1520-240-T). End cover (2) shall be visible through opening in winch (3).
3. Shut down electric and hydraulic power.
4. Remove end cover (2), retaining ring (4), and locking sleeve (5).
5. Remove ball end (6) from drum (7).

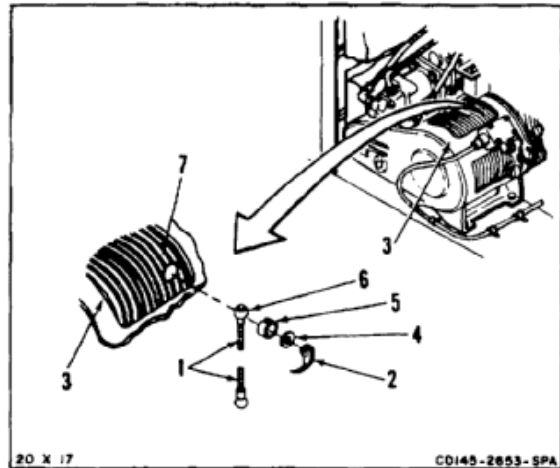

6. Remove four bolts (8), and washers (9), from winch (3).
7. Disconnect four hydraulic lines (10). Use container and cloths (E120) for spilled fluid. Cap lines.
8. Disconnect electrical plug (11).
9. Reposition winch (3) so back of winch faces aft. Position wooden block (12) under winch.

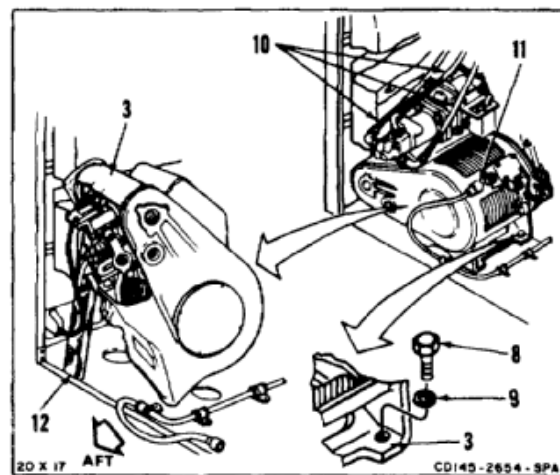

10. Cut lockwire and remove two screws (13).
11. Remove bracket (14), four washers (15), and two rollers (16) from posts (17).

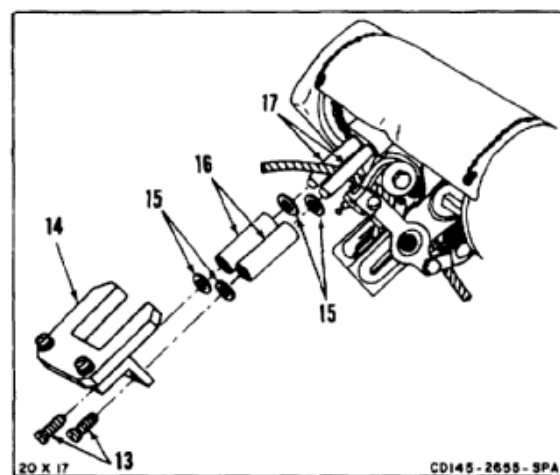



**14-10 REMOVE WINCH WIRE ROPE CABLE (Continued)**

14-10

12. With aid of helper, pull bracket (18) down.
13. Pull aft and remove wire rope (1) from pulleys (19) and posts (17).
14. Release bracket (18).

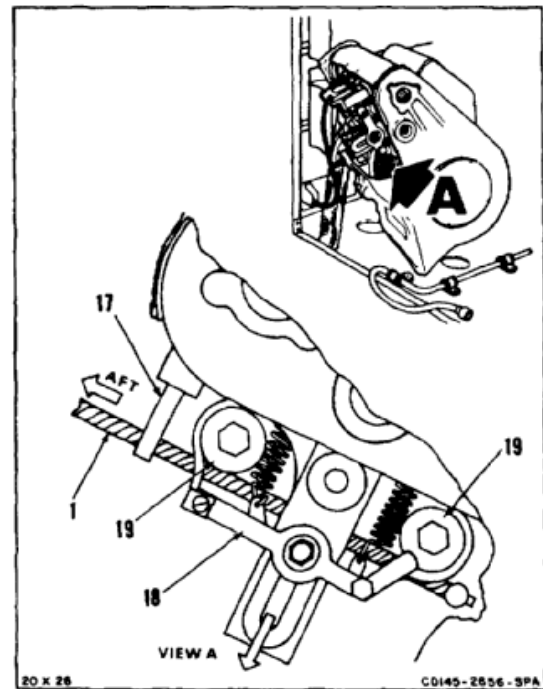

15. Remove three screws (20) from panel (21). Remove panel.
16. Reach under structure (22) and remove nut (23) and washer (24).
17. Remove bolt (25) and washer (26) from top of bracket (27).

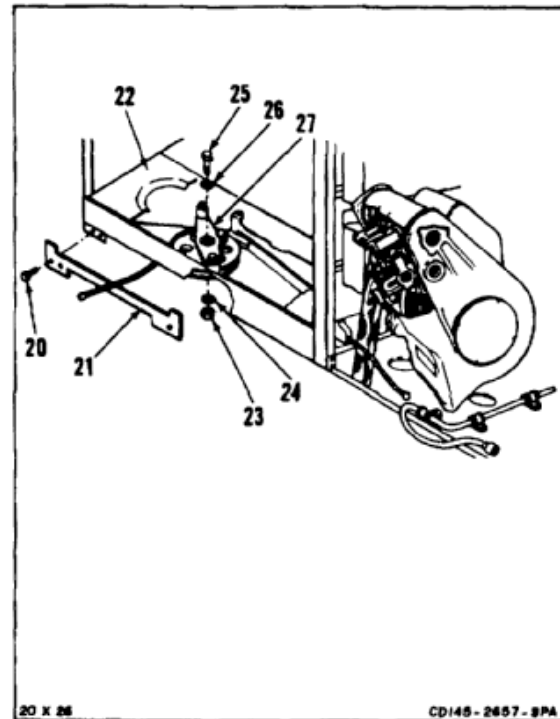

18. Make sure washers (28) stay in place on top and bottom of pulley (29).
19. Move pulley (29) aft just enough to clear ball end (6).
20. Guide wire rope (1) out from between pulley (29) and bracket (30).
21. Remove wire rope (1).

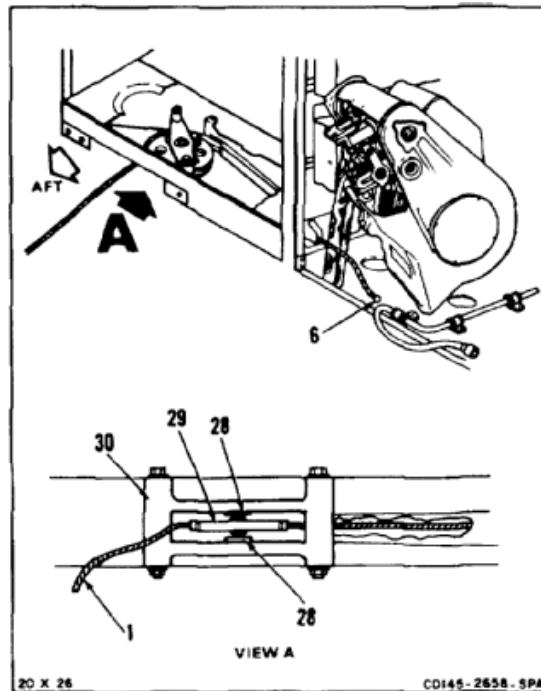
**FOLLOW-ON MAINTENANCE:**

None

END OF TASK

INITIAL SETUP

**Applicable Configurations:**

All

**Tools:**

Aircraft Mechanic's Tool Kit, NSN 51 80-00-323-4692  
 Container, Two Quart

**Materials:**

Cloths (E120)  
 Lockwire (E229)  
 Gloves, Wire Handling (E185)

**Personnel Required:**

Medium Helicopter Repairer (2)  
 Inspector

**References:**

TM 55-1520-240-23P  
 TM 55-1520-240-T

**General Safety Instructions:**

**WARNING**

Wear wire handling gloves when installing wire rope (cable). Otherwise, injury to hands can result.

1. Guide wire rope (1) through bracket (2) and guard (3) until cable ball end (4) extends past bulkhead (5).
2. Position pulley (6) forward in bracket (2). Wire rope (1) shall be forward in groove (7) of pulley.
3. Make sure two washers (8) are in place on top and bottom of pulley (6).

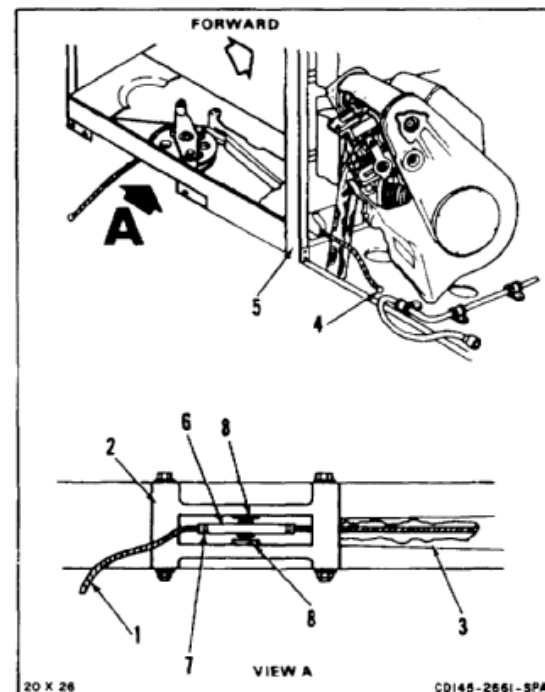
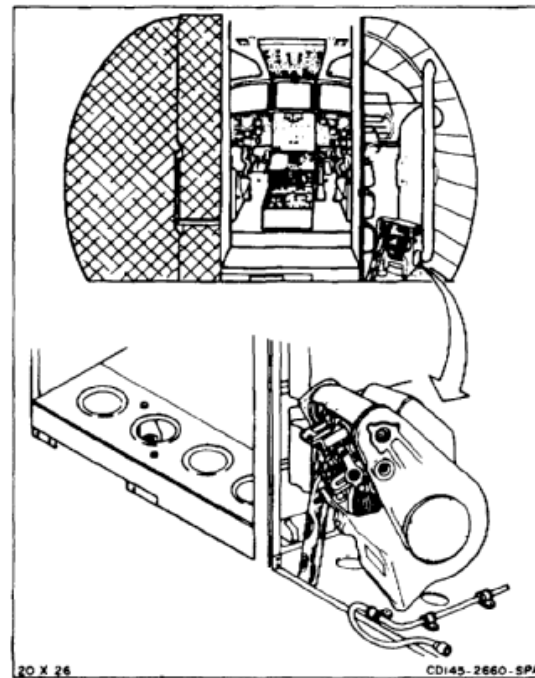

4. Install bolt (9), and washer (10) through bracket (2) and pulley (6).
5. Reach under structure (11) and install nut (12) and washer (13) on bolt (9).
6. Position panel (14) and install three screws (15).

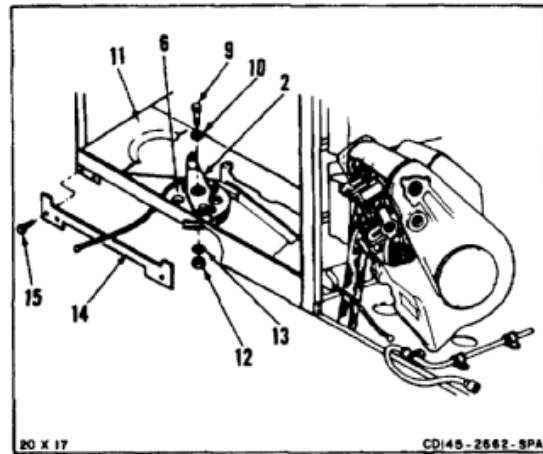

7. With aid of helper pull bracket (16) down.
8. Install wire rope (1) forward through posts (17) and pulleys (18).
9. Release bracket (16).

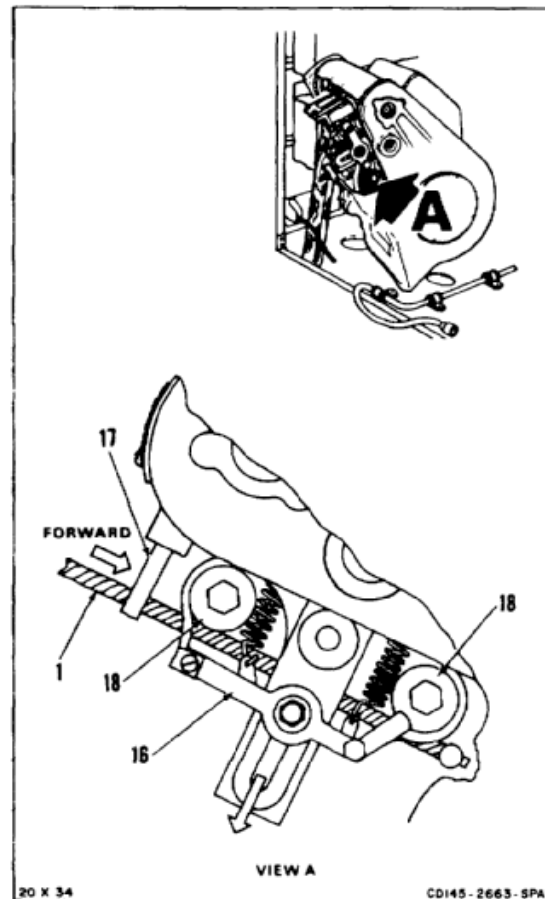

14-11 INSTALL WINCH WIRE ROPE (CABLE) (Continued)

10. Position four washers (19), two rollers (20), and bracket (21) on posts (17).
11. Install two screws (22) in bottom of posts (17). Lockwire screws with lockwire (E229).

**INSPECT**

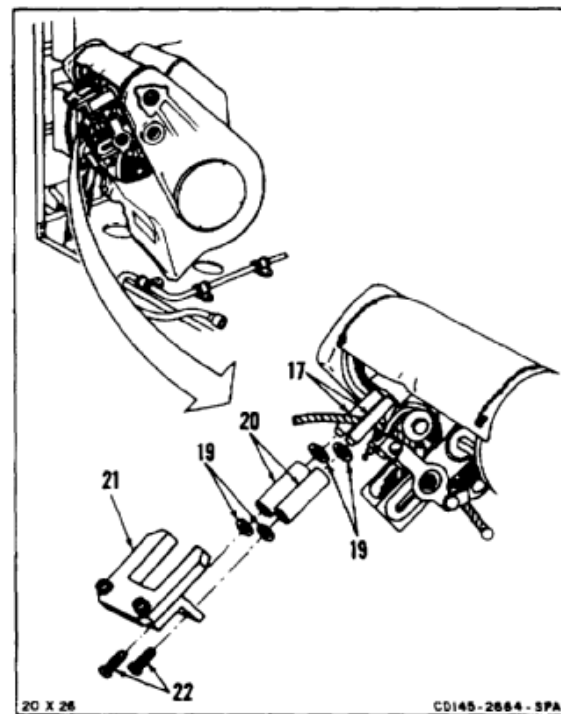

12. Remove wooden block (23).
13. Position winch (24) so back of winch faces inboard. Make sure guard (25) is aligned with wire rope (1) in back of winch.
14. Install four bolts (26) and washers (27) on winch (24).
15. Remove caps and connect four hydraulic lines (28). Use container and cloths (E120) for spilled fluid.
16. Connect electrical plug (29).

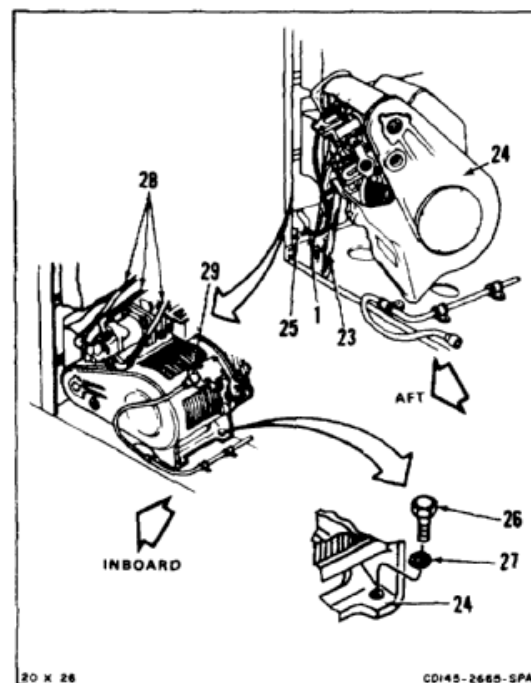

17. Pull ball end (4) up through winch housing (30).
18. Position ball end (4) in socket (31) on drum (32).
19. Install locking sleeve (33) and retaining ring (34).
20. Apply electric and hydraulic power.
21. Bleed utility hydraulic system.

**NOTE**

Keep tension on wire rope when reeling in wire rope. Wire rope will reel in evenly and will not snarl.

22. Have helper keep slight drag on wire rope (1). Helper must wear gloves (E185).
23. Reel in one wrap of wire rope (1) (TM 55-1520-240-T).

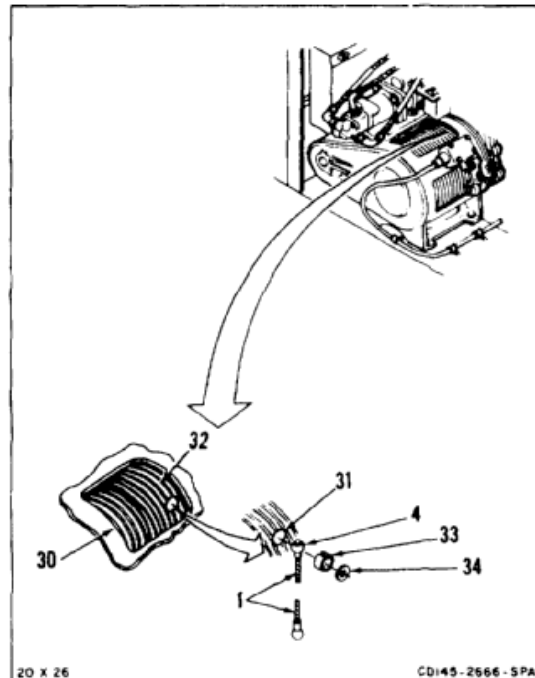

24. Raise wrap of wire rope (1) and install end cover (35) in socket (31).
25. Make sure wire rope (1) is pulled tight and holds end cover (35) in place.

**INSPECT**

26. Reel in all wire rope (1) (TM 55-1520-240-T).
27. Shut down electric and hydraulic power.

**FOLLOW-ON MAINTENANCE:**

Operate winch (TM 55-1520-240-T).  
 Install cockpit aft floor panel (Task 2-84).  
 Install heater compartment acoustic blanket (Task 2-210).

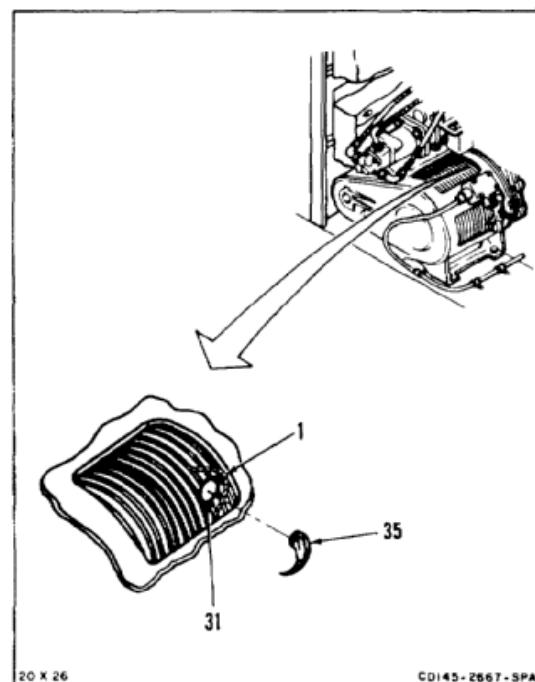

END OF TASK

## INITIAL SETUP

**Applicable Configurations:**

All

**Tools:**

Technical Inspection Tool Kit, NSN 5180-00-323-5114

**Materials:**

Cloths (E135)  
 Lubricant (E235)  
 Gloves, Wire Handling (E185)

**Personnel Required:**

Medium Helicopter Repairer  
 Inspector

**References:**

TM 1-1500-204-23

**Equipment Condition:**

Battery Disconnected (Task 1-39)  
 Electrical Power Off  
 Hydraulic Power Off  
 Heater Compartment Acoustic Blanket Removed  
 (Task 2-208)

**General Safety Instructions:****WARNING**

Wear wire handling gloves while handling cable. Broken wires can injure hands.

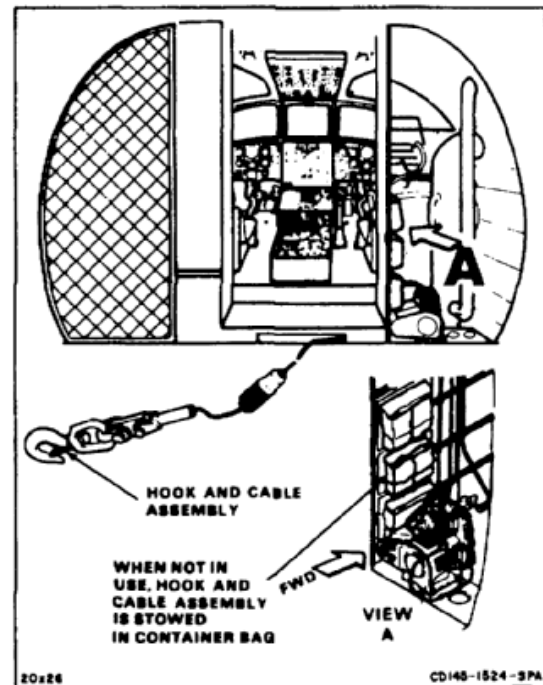

1. Disconnect upper half of quick disconnect cable guard (1) from lower half of cable guard (2).
2. Check hook (3) and cable (4) for corrosion.
3. Check that hook (3) turns freely. If it does not, apply light coat of dry lubricant (E235) to pivot (5).
4. Check safety latch (6) for cracks, nicks, and proper spring action.
5. Check cable (4) for broken strands or fraying. (Refer to TM 1-1500-204-23.) Trim wire ends flush with cable. Use cloth (E135).

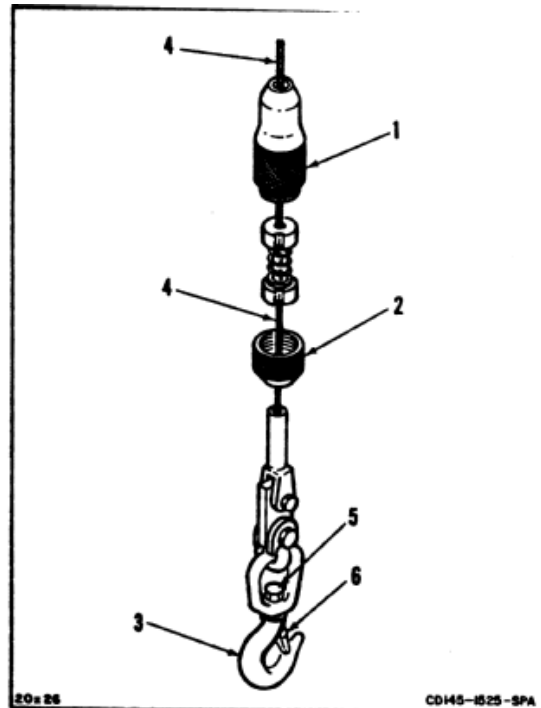

6. Check upper half of guard (1) and lower half of cable guard (2). There shall be no cracks or stripped thread.
7. Check quick-disconnect coupling (7). There shall be no broken spring (8), cracks, or corrosion.
8. Remove and stow hook and cable assembly (9) in pocket (10) of stowage container (11) (if required) (Task 14-13).

**FOLLOW-ON MAINTENANCE:**

Install heater compartment acoustic blanket (Task 2-210).

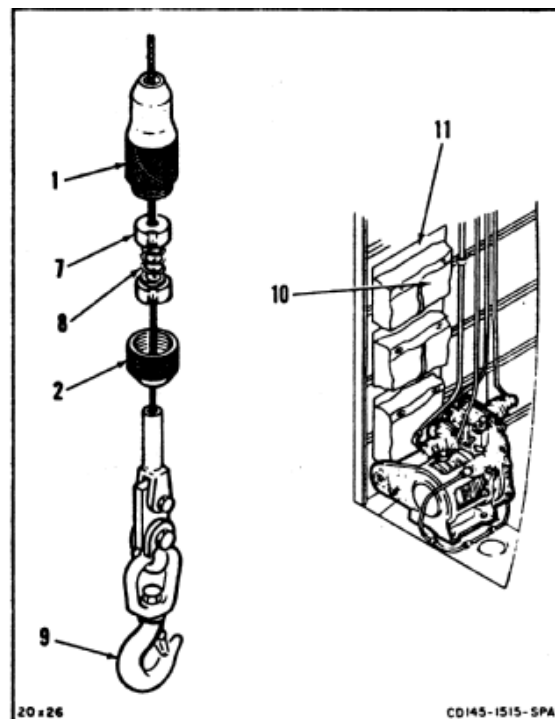

END OF TASK



INITIAL SETUP

**Applicable Configurations:**

All

**Tools:**

None

**Materials:**

None

**Personnel Required:**

Medium Helicopter Repairer

**Equipment Condition:**

- Battery Disconnected Task (1-39)
- Electrical Power Off
- Hydraulic Power Off

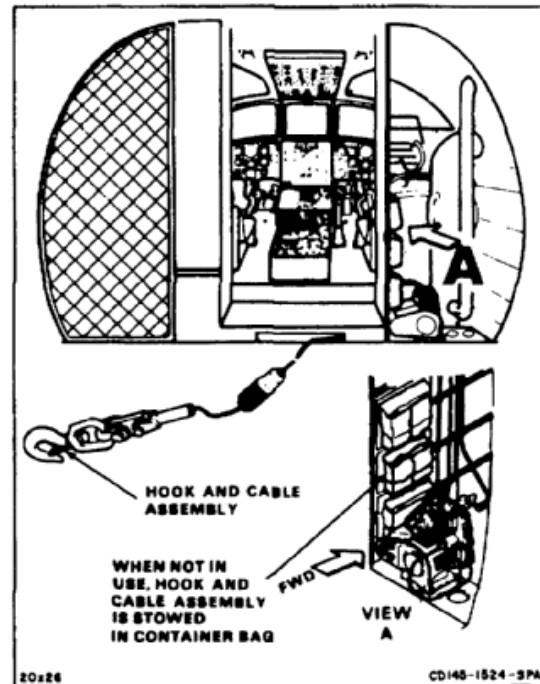

1. Disconnect quick-disconnect cable guard (1) from lower half of cable guard (2).
2. Push up and hold lower end of spring-loaded coupling (3).
3. Remove cable (4) and ball end (5) from coupling (3).
4. Release coupling (3).
5. Remove lower half of cable guard (2) from cable (4). Remove hook and cable assembly (7).
6. Connect guard (2) to upper half of cable guard (1).

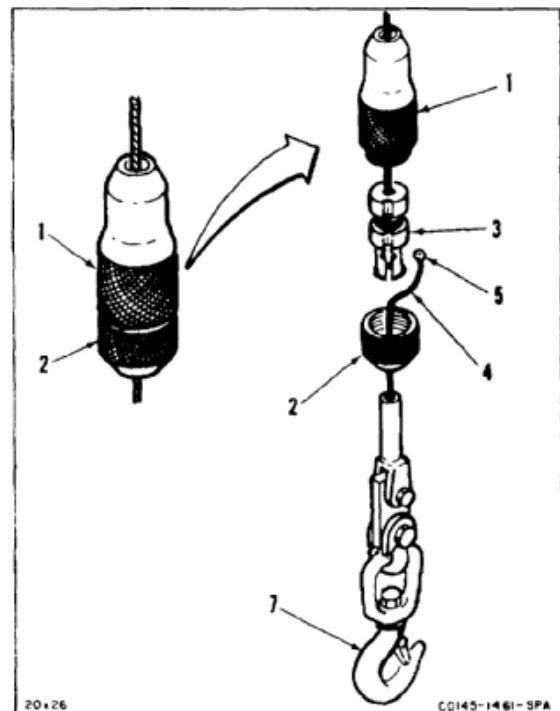

**FOLLOW-ON MAINTENANCE:**

None

END OF TASK

## INITIAL SETUP

**Applicable Configurations:**

All

**Tools:**

None

**Materials:**

None

**Personnel Required:**Medium Helicopter Repairer  
Inspector**References:**

TM 55-1520-240-23P

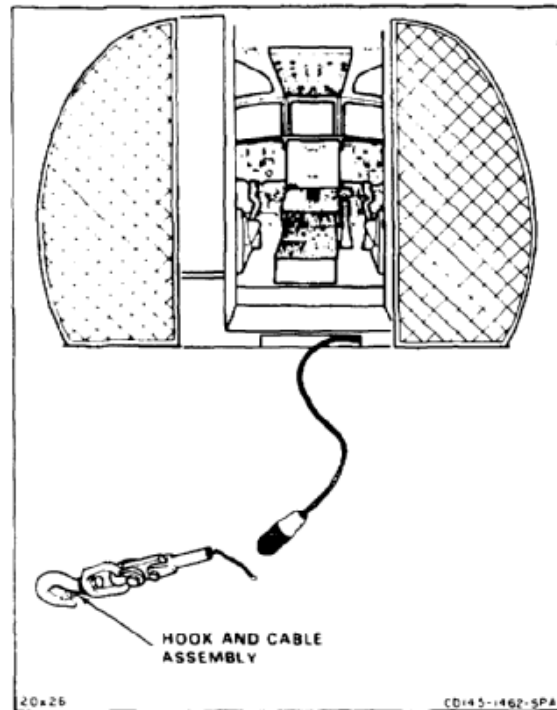
**WARNING**

Quick-disconnect cable guard must be installed during all rescue and cargo operations. Otherwise hook assembly can be accidentally disconnected from coupling. This can result in death or serious injury to personnel.

1. Remove upper half of quick-disconnect cable guard (1) from lower half of cable guard (2).
2. Install cable (3), through lower half of cable guard (2).
3. Push up and hold lower end of spring-loaded coupling (4).
4. Install ball end (5) of cable (3) into coupling (4).
5. Release lower end of coupling (4).
6. Connect guard (2) to upper half of cable guard (1).

**INSPECT****FOLLOW-ON MAINTENANCE:**

None

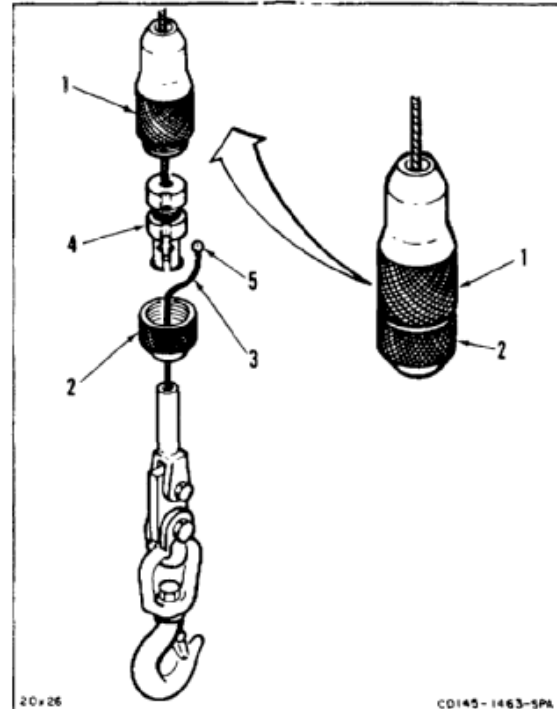

END OF TASK

**14-15 REMOVE CABLE CUTTER**

14-15

**INITIAL SETUP****Applicable Configurations:**

All

**Tools:**

Aircraft Mechanic's Tool Kit, NSN 51 80-00-323-4692

**Materials:**Cloths (E135)  
Lubricating Oil (E250)**Personnel Required:**

Medium Helicopter Repairer

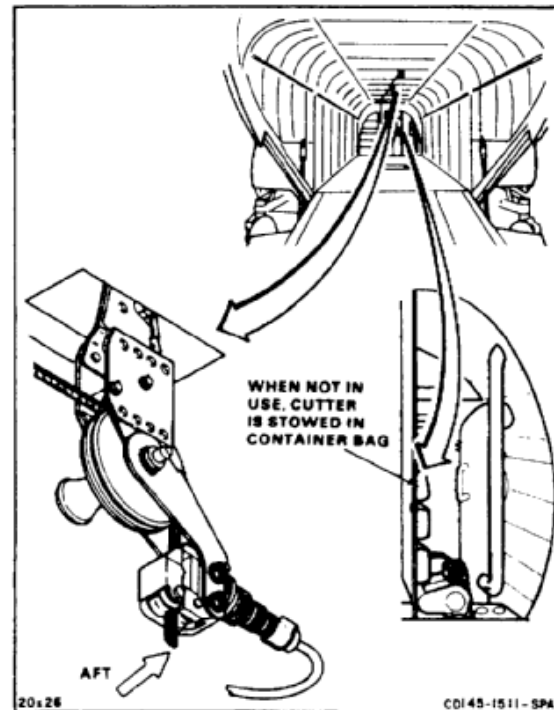
**References:**Task 1-75  
Task 14-16**Equipment Condition:**Battery Disconnected (Task 1-39)  
Electrical Power Off  
Hydraulic Power Off

1. If cartridge was fired without cable in place, inspect cable cutter (Task 14-16).
2. If cartridge was fired with cable in place, service cable cutter (Task 1-75).
3. Disconnect connector (1).
4. Push in keeper (2) and remove cable block (3).
5. Remove lockwire. Disconnect connector (4).
6. Remove adapter (5) and key washer (6).

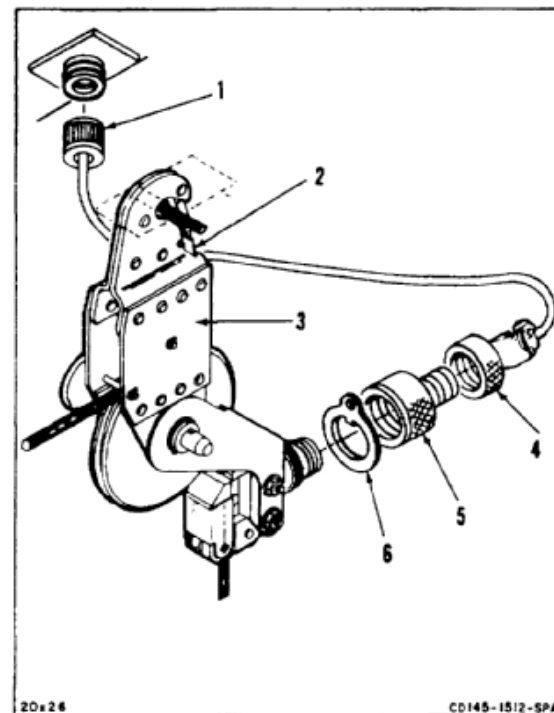

7. If cable is installed in cutter, push in lockpin (7) and remove locknut (8). Pull down guard (9) and push cable cutter (10) forward. Remove cable (11).

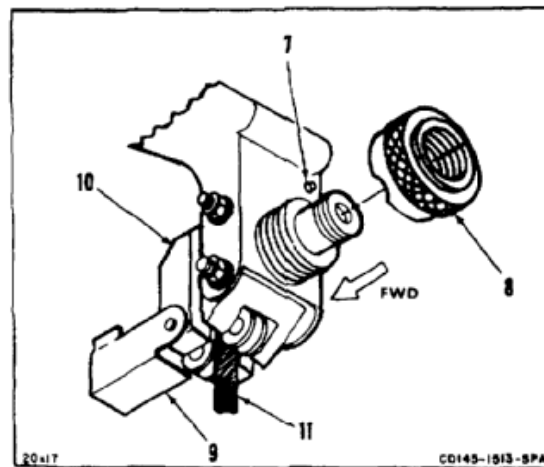

**WARNING**

Use care when handling cartridges. Injury to personnel could result if cartridge fires.

8. If cable cutter will be stowed, pull down guard (9). Remove cartridge (12).
- 8.1. Place serviceable cartridge in a protective container. Tag container with helicopter serial number and cartridge installation date for quick reference.
9. Push in lockpin (7) and remove locknut (8).
10. Remove two screws (13), nuts (14), and four washers (15). Remove cable cutter (10).
11. Lightly coat cable cutter (10) with lubricating oil (E250) using cloths (E135).

**FOLLOW-ON MAINTENANCE:**

None

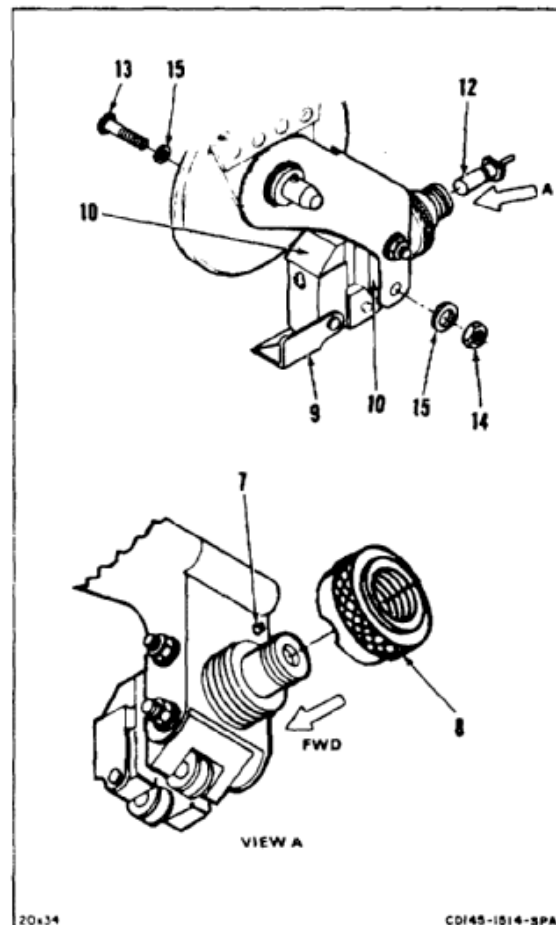

END OF TASK

## INITIAL SETUP

**Applicable Configurations:**

All

**Tools:**

None

**Materials:**

Cleaning Brush (E84)  
 Cloths (E135)  
 Dry Cleaning Solvent (E162)  
 Lubricating Oil (E250)  
 Powder Solvent (E464)  
 Gloves (E186)

**Personnel Required:**

Medium Helicopter Repairer  
 Inspector

**Equipment Condition:**

Off Helicopter Task

1. Clean cartridge chamber (1). Use powder solvent (E464) and cleaning brush (2) (E84).

**WARNING**

Dry cleaning solvent (E162) is flammable and toxic. It can irritate skin and cause burns. Use only in well-ventilated area away from heat and open flame. In case of contact, immediately flush skin or eyes with water for at least **15 minutes**. Get medical attention for eyes.

2. Clean cable cutter (3) except chamber (1). Use clean cloth (E135) wet with solvent (E162). Let parts air dry. Wear gloves (E186).

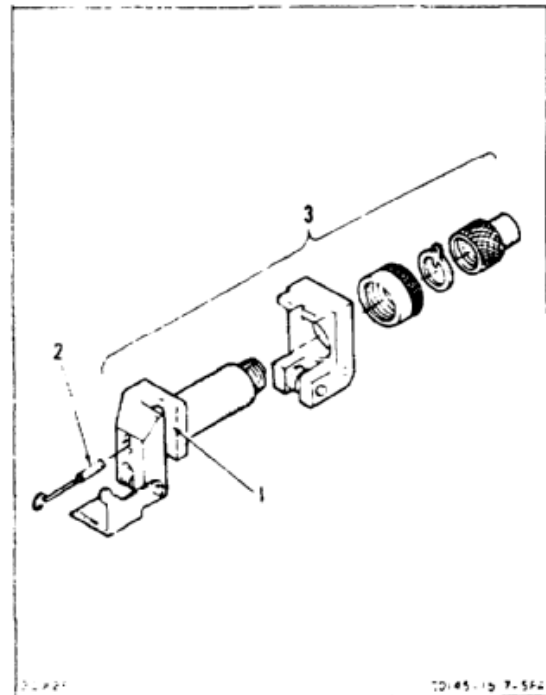

3. If cable cutter (3) has been fired without cable in place, log report of firing. Fill out inspection record and record serial number of cable cutter.
4. Check cable cutter (3) for corrosion, cracks, or nicks.
5. Coat all parts lightly with oil (E250) using cloths (E135).

**WARNING**

Use care when handling cartridges.  
Injury to personnel could result if  
cartridge fires.

6. Dispose of unserviceable live cartridges. Place them in empty can that contained replacement cartridge. Tag can unserviceable. On the tag write the reason for cartridge removal, date of removal, and date of installation. Return the cartridge to the Ammunition Supply Activity.

**INSPECT****FOLLOW-ON MAINTENANCE:**

None

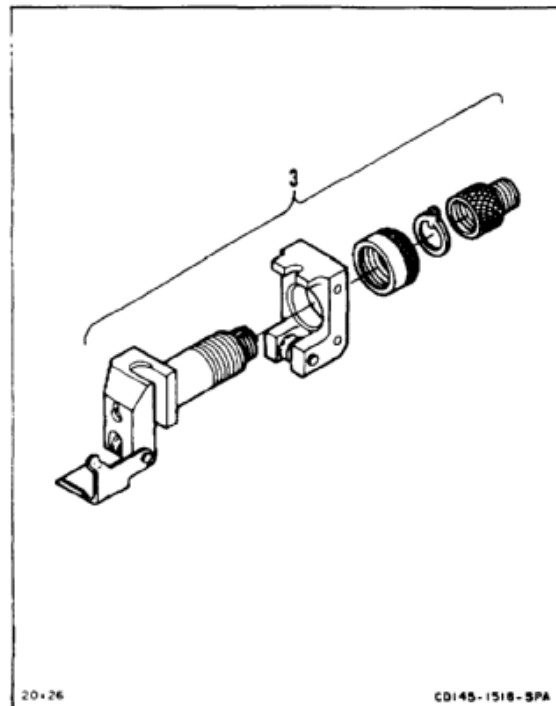

END OF TASK

## INITIAL SETUP

**Applicable Configurations:**

All

**Tools:**

Aircraft Mechanic's Tool Kit, NSN 51 80-00-323-4692

**Materials:**

Lockwire (E231)

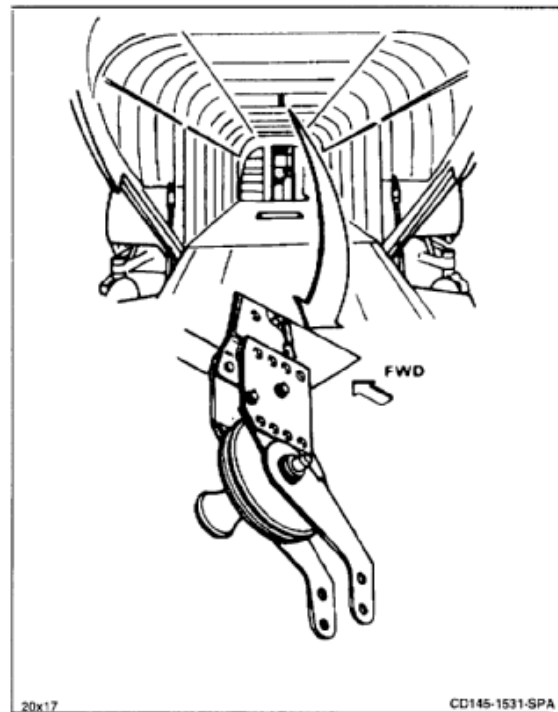
**Personnel Required:**Medium Helicopter Repairer  
Inspector**References:**Task 1-75  
TM 55-1520-240-23P**NOTE**

Make sure roller faces forward.

1. Position rear half of cable cutter (1) in bracket (2).
2. Align two holes in cutter (1) with holes (3). Install two screws (4), four washers (5), and two nuts (6).

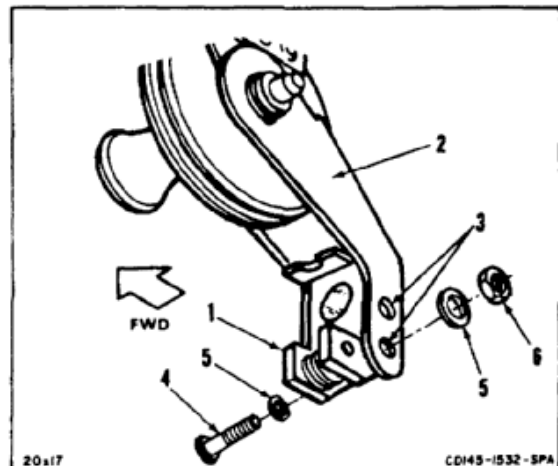

**NOTE**

If cable block will be used, perform steps 3 thru 7. If cable block will not be used, go to step 8.

3. Install cable block (7) on overhead hook (8).
4. Remove quick-disconnect pin (9) and remove pulley (10).
5. Place cable (11) between pulley (10) and cable block (7).
6. Place pulley (10) in cable block (7). Install pin (9).
7. Retain cable (11) between rollers (12) by installing forward half of cable cutter (1).

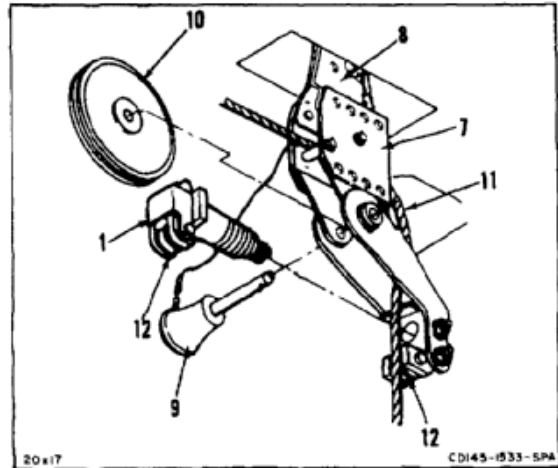

**CAUTION**

A loaded cutter is a hazard. Insert cartridge only if cutter is to be used. Do not install if cutter will be stowed.

8. Push in lockpin (13). Install locknut (14).
9. If cutter is to be used, insert cartridge (15) (Task 1-75).
- 9.1. Write cartridge lot number, date cartridge was installed, and date cartridge was removed on DA Form 2408-16.

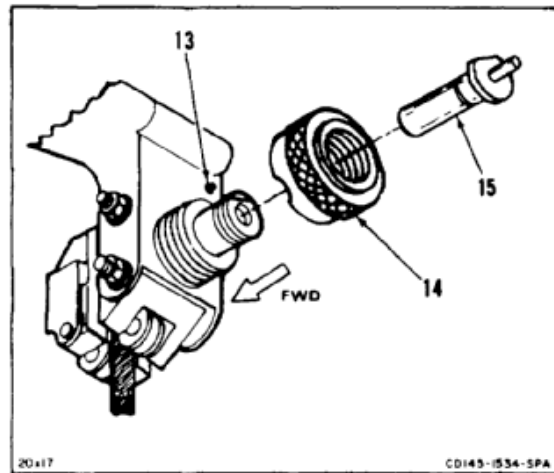

10. If cartridge is not inserted, install key washer (16) and lock adapter (17). Lockwire adapter to key washer using lockwire (E231).
11. Install electrical connector (18). Secure it to adapter (17) with lockwire (E231).

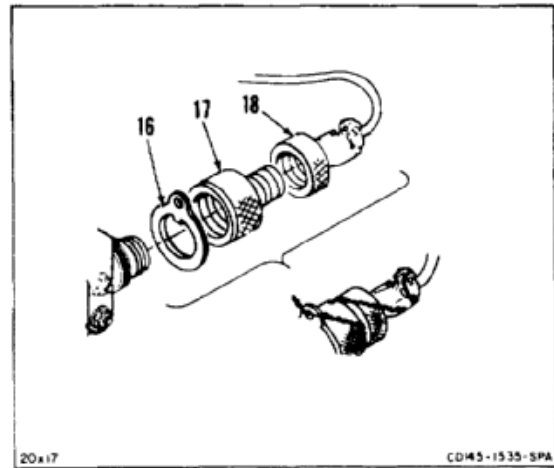



**NOTE**

Connect connector only if cutter is to be used. Stow cable block and cutter in container if it will not be used.

12. If cutter is to be used, connect connector (19).

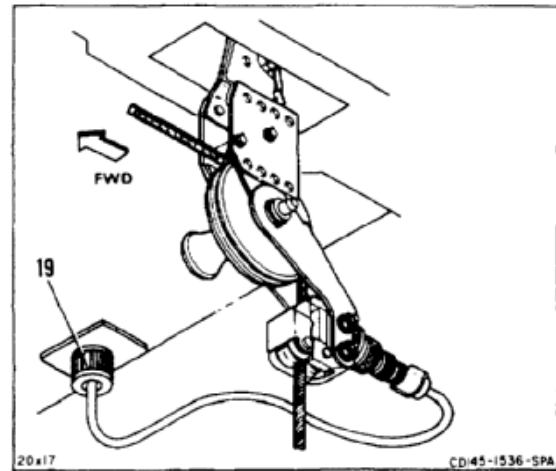
**INSPECT****FOLLOW-ON MAINTENANCE:**

None

END OF TASK

INITIAL SETUP

**Applicable Configurations:**

All

**Tools:**

None

**Materials:**

None

**Personnel Required:**

Inspector

**References:**

TM 1-1500-204-23

**Equipment Condition:**

- Battery Disconnected (Task 1-39)
- Electrical Power Off
- Hydraulic Power Off
- Heater Compartment Acoustic Blanket Removed (Task 2-208)

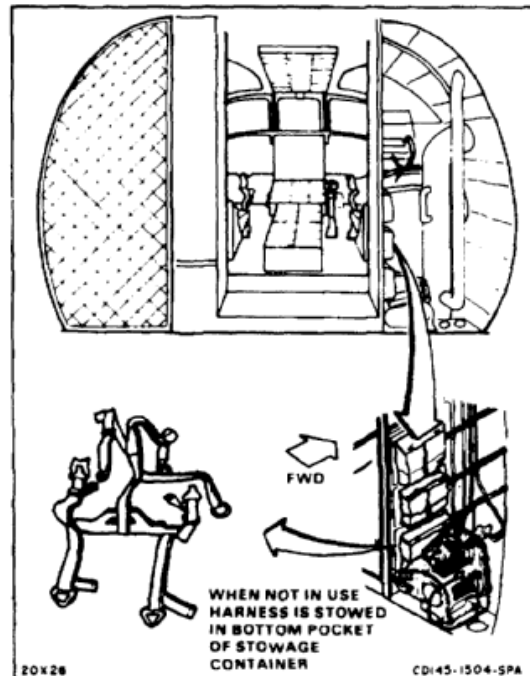

1. Check harness (1) for cuts or fraying (TM 1-1500-204-23).
2. Check fittings (2) for corrosion and proper operation (TM 1-1500-204-23).
3. Check lockring (3) for corrosion (TM 1-1500-204-23).
4. Check webbing for deterioration (TM 1-1500-204-23).
5. Stow operator's harness (1) in bottom pocket (4) of stowage container (5).

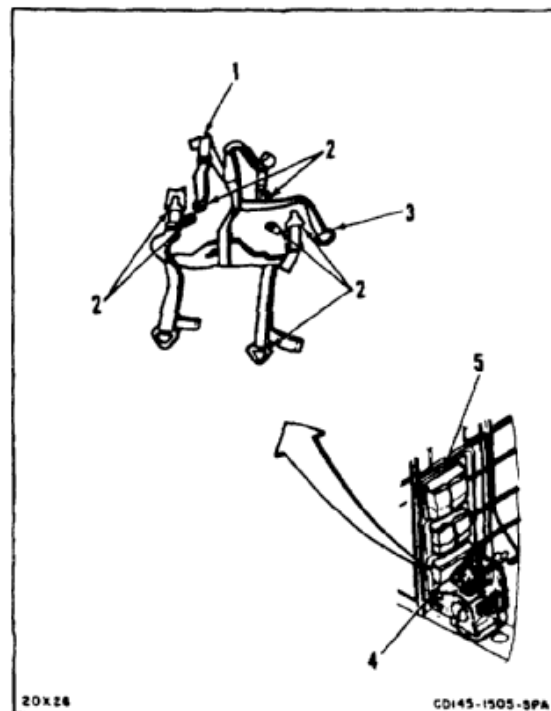

**FOLLOW-ON MAINTENANCE:**

None

END OF TASK

**14-19 REMOVE STOWAGE CONTAINER**

14-19

**INITIAL SETUP****Applicable Configurations:**

All

**Tools:**

Aircraft Mechanic's Tool Kit, NSN 51 80-00-323-4692

**Materials:**

None

**Personnel Required:**

Medium Helicopter Repairer

**Equipment Condition:**

Battery Disconnected (Task 1-39)  
 Electrical Power Off  
 Hydraulic Power Off  
 Heater Compartment Acoustic Blanket Removed  
 (Task 2-208)

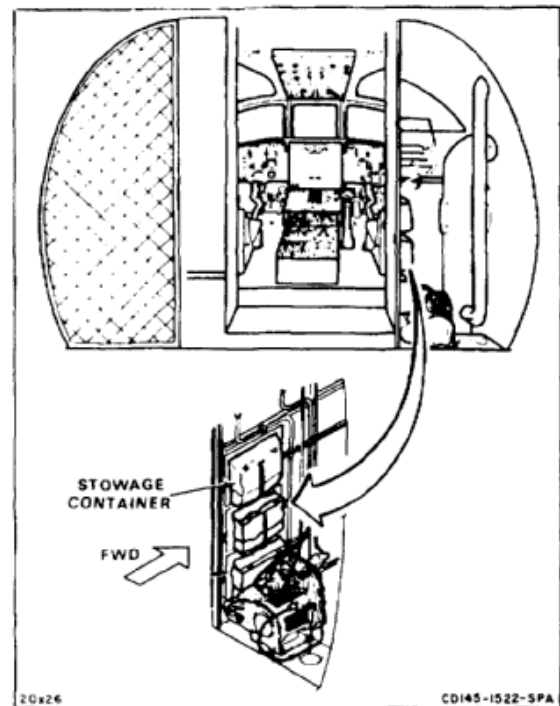

1. Remove parts from pockets (1).
2. Remove five screws (2) and washers (3).
3. Remove stowage container (4).

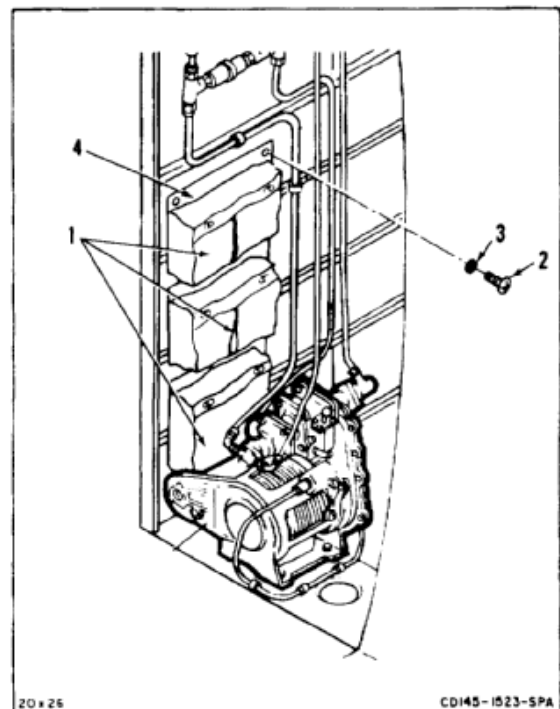
**FOLLOW-ON MAINTENANCE:**

None

END OF TASK

INITIAL SETUP

**Applicable Configurations:**

All

**Tools:**

Aircraft Mechanic's Tool Kit, NSN 5180-00-323-4692

**Materials:**

None

**Personnel Required:**

Medium Helicopter Repairer

**References:**

TM 55-1520-240-23P

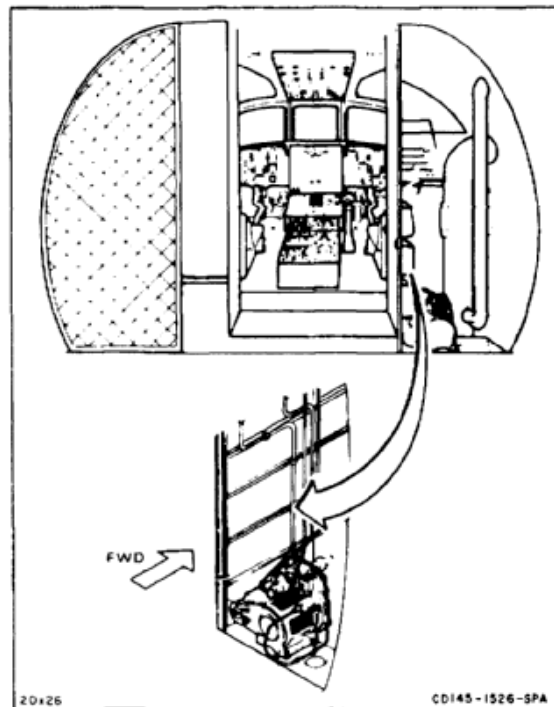

1. Position stowage container (1) on bulkhead (2).
2. Install five washers (3) and screws (4).
3. Stow parts in pockets (5).

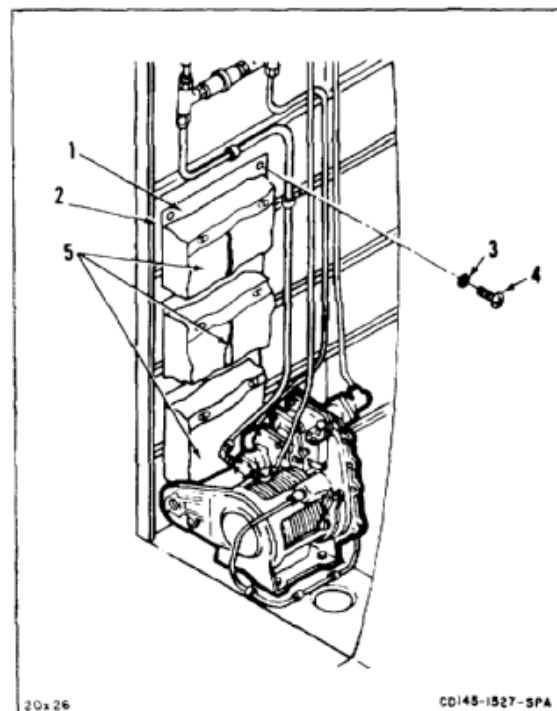

**FOLLOW-ON MAINTENANCE:**

None

END OF TASK

INITIAL SETUP

**Applicable Configurations:**

All

**Tools:**

None

**Materials:**

None

**Personnel Required:**

Medium Helicopter Repairer

**References:**

Task 14-15

**Equipment Condition:**

- Battery Disconnected (Task 1-39)
- Electrical Power Off
- Hydraulic Power Off

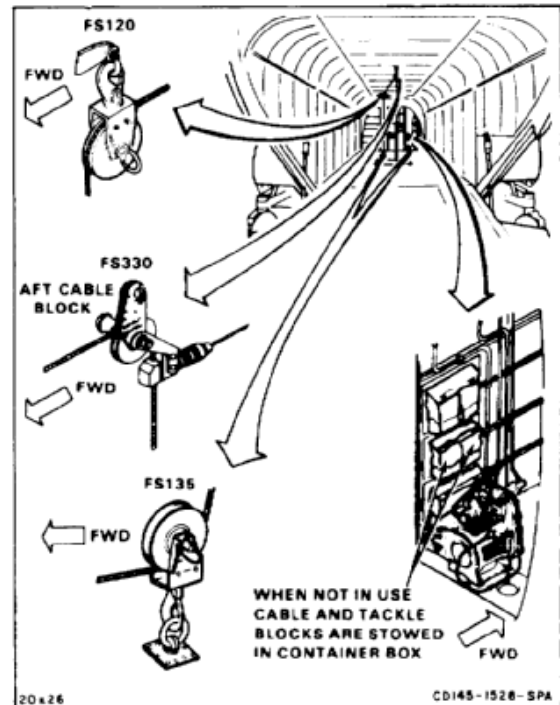

**WARNING**

Make sure there is no load on cable. Serious injury to personnel or damage to equipment can occur.

**NOTE**

Procedure is same for all tackle blocks except aft cable block. Aft cable block may have cable cutter installed.

1. Hold pulley (1) and remove quick disconnect pin (2). Remove pulley (1).
2. Remove cable (3) from cable block (4).
3. Position pulley (1) in cable block (4). Install pin (2).
4. For an aft cable block, remove cable cutter (5), if installed (Task 14-15).
5. Push in keeper (6) and remove cable block (4).
6. Stow cable or tackle blocks in pockets (7) of stowage container (8).

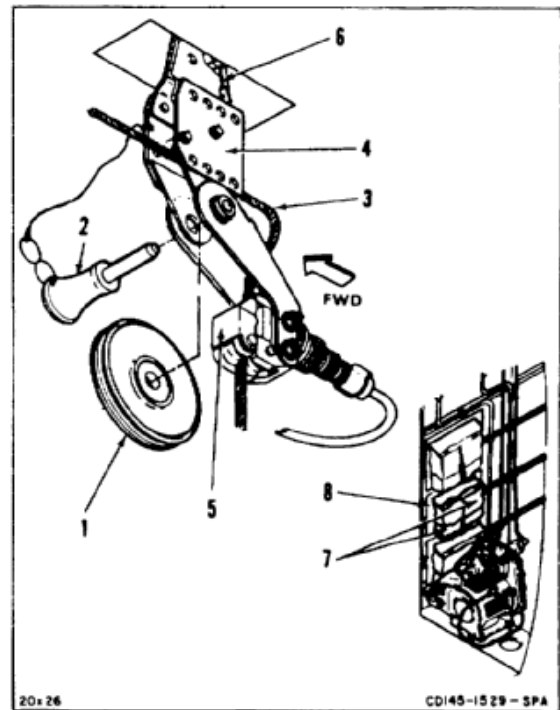

**FOLLOW-ON MAINTENANCE:**

None

END OF TASK

## INITIAL SETUP

**Applicable Configurations:**

All

**Tools:**

None

**Materials:**

None

**Personnel Required:**

Medium Helicopter Repairer

**References:**

Task 14-17

TM 55-1520-240-23P

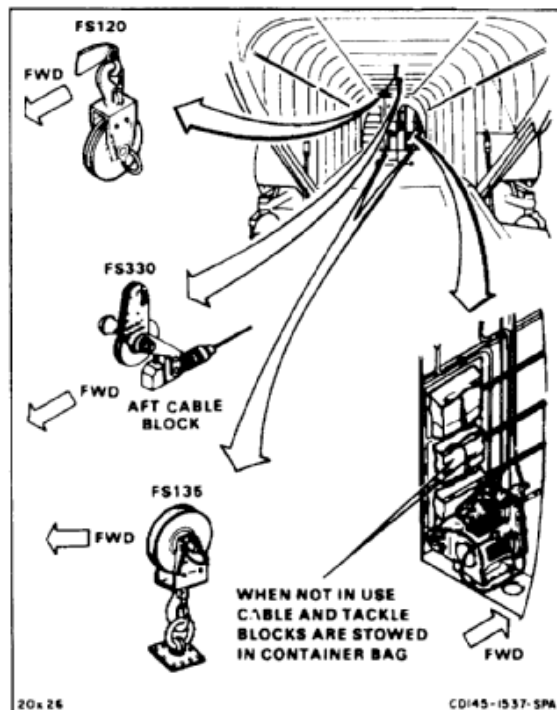
**WARNING**

Aft cable block may have cable cutter installed. Make sure there is no load on cable. Serious injury to personnel or damage to equipment can occur.

**NOTE**

Procedure is same for all tackle blocks except aft cable block.

1. Remove cable block (1) from pocket (2) of storage container (3).
2. Position cable block (1), push in keeper (4), and install cable block (1).
3. For an aft cable block, install cable cutter (5), if required (Task 14-17).
4. Remove quick-disconnect pin (6) and remove pulley (7).
5. Position cable (8) between pulley (7) and cable block (1).
6. Position pulley (7) in cable block (1) and install pin (6).

**FOLLOW-ON MAINTENANCE:**

None

END OF TASK

14-58

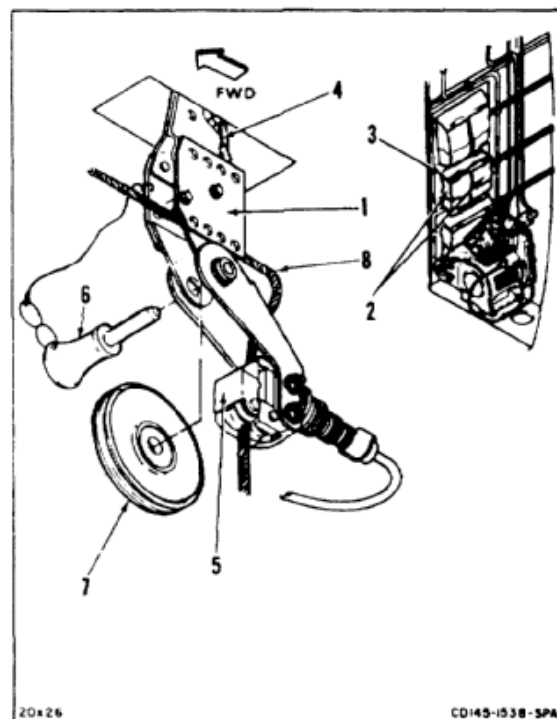

# **CHAPTER 15**

# **AUXILIARY POWER UNIT**

## **SECTION I**

### **AUXILIARY POWER UNIT DESCRIPTION AND SEQUENCE OF OPERATION**

**DESCRIPTION**

The auxiliary power unit (APU) is a gas turbine engine that provides hydraulic and electrical power for engine starting and ground maintenance. The complete APU system includes the APU, an electronic sequence unit (ESU), a switch, relays, a start module, and a start accumulator. Fuel supply components include a fuel valve, boost pump, and manual shutoff valve.

A hydraulic motor-pump is mounted on the front of the APU. To start the APU, the motor-pump is driven by pressurized hydraulic fluid from the utility hydraulic system, supplied by the start accumulator. When the APU is operating, the motor-pump operates as a pump to pressurize the flight control and utility hydraulic systems. An ac generator is driven by the APU to supply power to the electrical system during ground operation. Refer to TM 55-2835-205-23 for more detailed information on the APU.

The ESU is a microprocessor with built-in test equipment (BITE) facilities. The ESU automatically sequences the start procedure and continuously monitors APU operation. If the operating sequence is not normal or the operation is not within normal limits, the ESU stops the APU and shows fault displays that give the reason for shutdown. Information to decode the fault display is on a placard on the ESU.

**SEQUENCE OF OPERATION**

The APU is started and stopped through a three-position switch on the overhead ELECT panel. During normal starts, operating power is obtained from the **28 vdc** essential bus. Emergency start power is obtained from the battery bus.

Placing the APU switch to RUN provides power to operate the fuel pump and open the fuel solenoid valve. It also applies power to the electronic sequencing unit (ESU) and resets the built-in test equipment (BITE) indicators. Moving the switch to START energizes the solenoid valve on the APU start module. The valve opens to allow pressurized fluid to flow from the start accumulator to operate the motor-pump on the front of the APU.

As the motor-pump increases APU rpm, a magnetic pickup on the APU generates a signal proportional to APU speed.

**NOTE**

The starting sequence can be interrupted at any point and the APU shut down by closing the manual shutoff fuel valve.

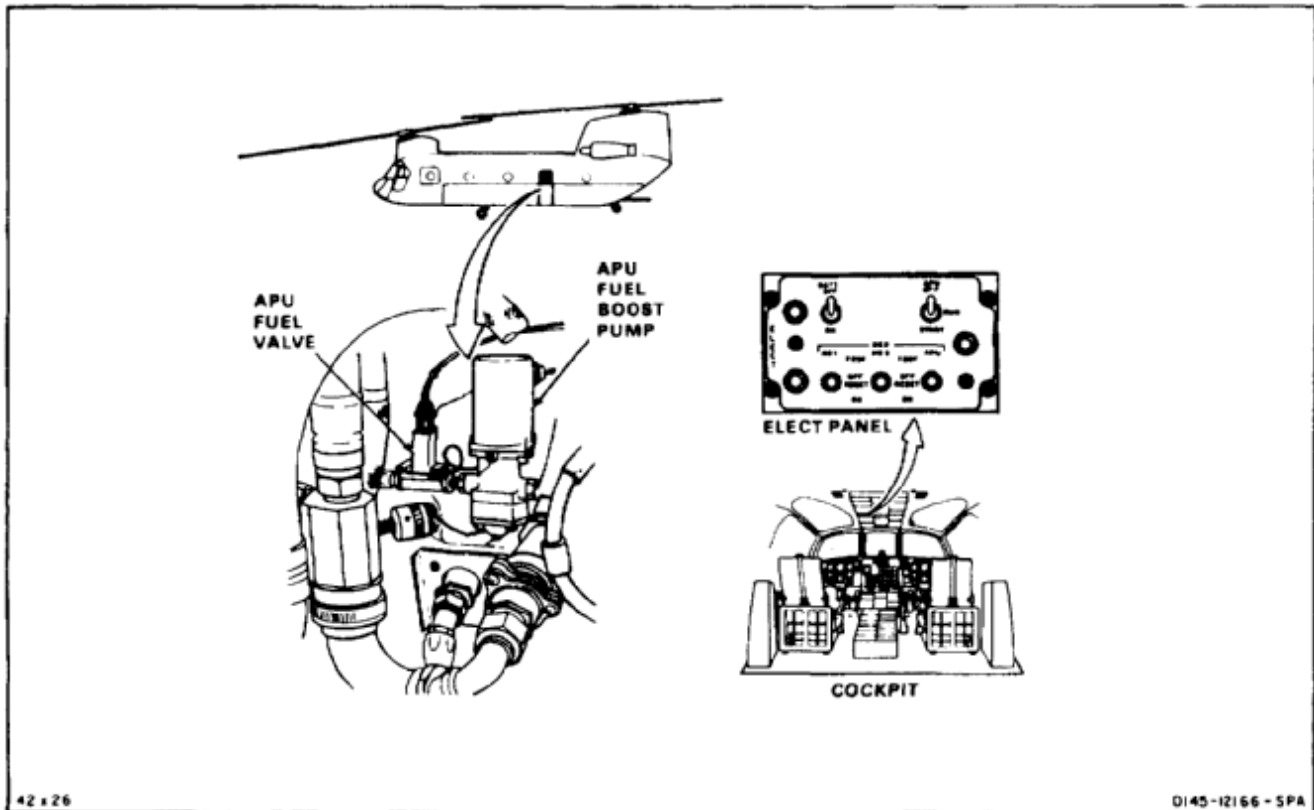



At about **5 percent** of rated speed, the ESU applies power to the ignition exciter and opens the start fuel valve. It also activates a **40 second** timer. Fuel flows through the start fuel valve and a start fuel nozzle into the combustor, where it is vaporized and ignited by the exciter-energized igniter plug. The burning fuel mixture increases APU speed.

At about **14 percent** of rated speed, the ESU opens the main fuel valve, allowing fuel to flow through the six main vaporizer tubes into six fuel injectors. The injectors direct fuel into the combustor, increasing APU speed.

At about **20 percent**, the charge in the start accumulator is depleted and the motor-pump no longer drives the APU.

At about **70 percent**, combustion is self-sustaining. Power is removed from the ignition exciter and start fuel solenoid.

At about **90 percent** the motor-pump becomes a pump and is driven by the APU to recharge the accumulator. After **1.5 seconds** the APU ON light on the master caution panel comes on. If **90 percent rpm** is not attained within **40 seconds** of when start power was applied to the ESU (**5 percent**) rpm, a fault relay cuts off fuel to the APU.

If the temperature or speed of an operating APU becomes abnormal, the ESU will automatically shut it down. Overtemperature during the start sequence is anything over a sustained **1,250°F (677°C)**. During operation, it is anything over **1,150°F (621°C)**.

Overspeed is anything more than about **110 percent** of rated speed. The APU will also shut down if speed drops below **90 percent 1.5 seconds** after attaining that speed.

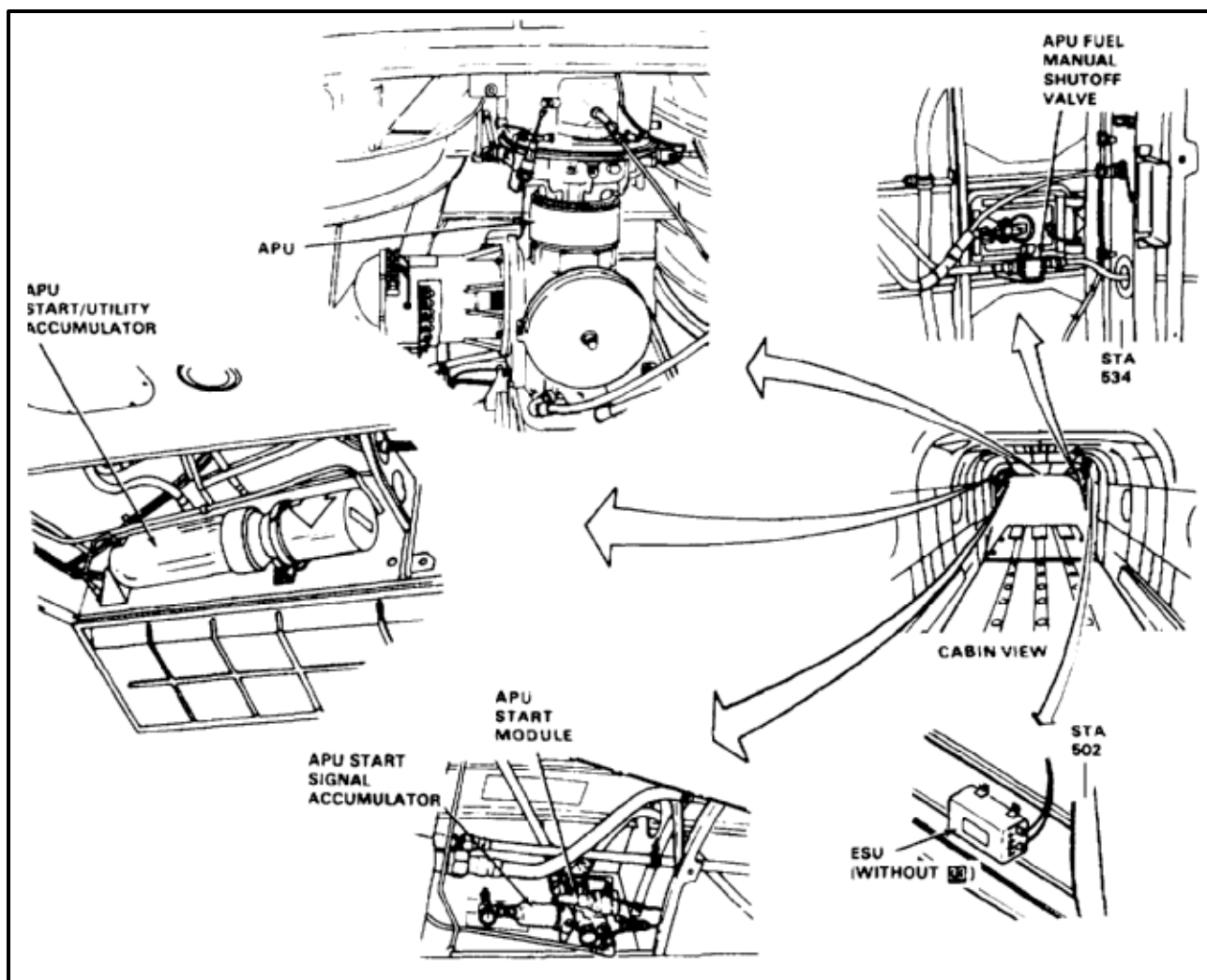

END OF TASK



**SECTION II**  
**AUXILIARY POWER UNIT**

## INITIAL SETUP

**Applicable Configurations:**

All

**Tools:**Aircraft Mechanic's Tool Kit, NSN 5180-00-323-4692  
Workstand**Materials:**

None

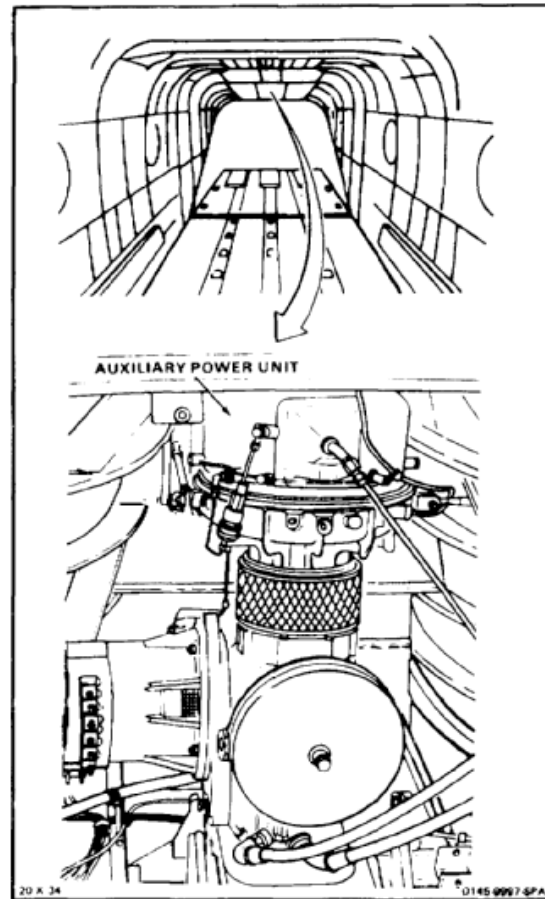
**Personnel Required:**Medium Helicopter Repairer  
Inspector**References:**Task 1-103  
Task 7-143  
Task 9-33  
TM 55-2835-205-23**Equipment Condition:**Battery Disconnected (Task 1-39)  
Electrical Power Off  
Hydraulic Power Off

**15-2 PRESERVATION OF AUXILIARY POWER UNIT APU (Continued)**

15-2

1. Preserve installed APU (Task 1-103).
2. Preserve uninstalled APU as follows:
  - a. Remove hydraulic motor pump (1) if installed (Task 7-143).
  - b. Remove generator (2) (Task 9-33).
  - c. Cover air inlet (3), exhaust openings (4) and reduction drive housing output pads (5).
  - d. Preserve APU (TM 55-2835-205-23).

**INSPECT**

3. Preserve inoperative APU (TM 55-2835-205-23).

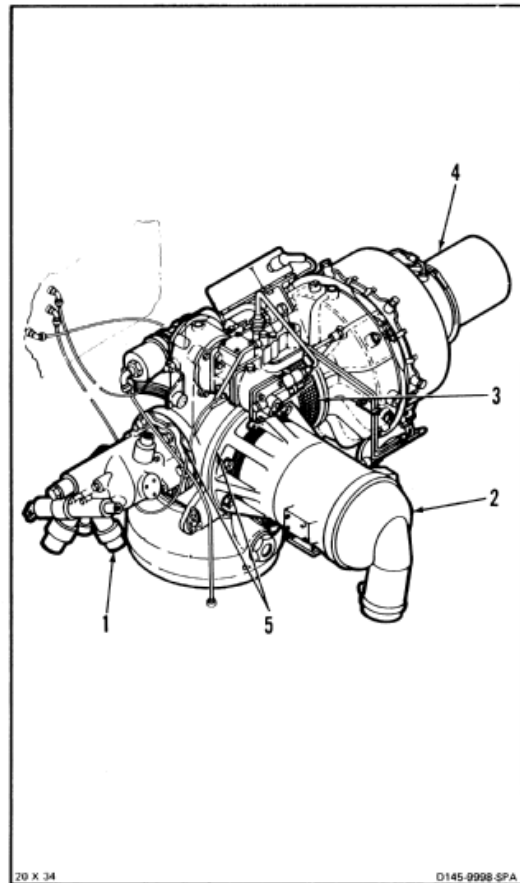
**INSPECT****FOLLOW-ON MAINTENANCE:**

None

END OF TASK

INITIAL SETUP

**Applicable Configuration:**

All

**Tools:**

- Aircraft Mechanic's Tool Kit, NSN 5180-00-323-4692
- Bomb Hoist, (T166)
- Grounded Container, 2 Quart
- Padded Support
- Tackle Block (T165)
- Trailer 1000334
- Wood Planks, 1 Inch X 8 Inch X 5-1/2 Feet (10)
- Workstand

**Materials:**

- Cloths (E135)
- Paper Tags (E264)
- Tape (E385)
- Twine (E433)

**Parts:**

- Bolt
- Nut

**Personnel Required:**

Medium Helicopter Repairer (3)

**Equipment Condition:**

- Battery Disconnected (Task 1-39)
- Hydraulic Power Off
- Cargo Ramp Open and Level (TM 55-1520-240-T)
- Ramp Work Platform Open (Task 2-2)
- APU Drip Pan Remove (Task 2-3)
- Aft Transmission Access Panels Open (Task 2-2)
- Aft Transmission Drip Pan Removed (Task 2-3)
- Remove APU Motor Pump (Task 7-143)

**General Safety Instructions:**

**WARNING**

All regulation and instructions for handling fuels shall be strictly observed.

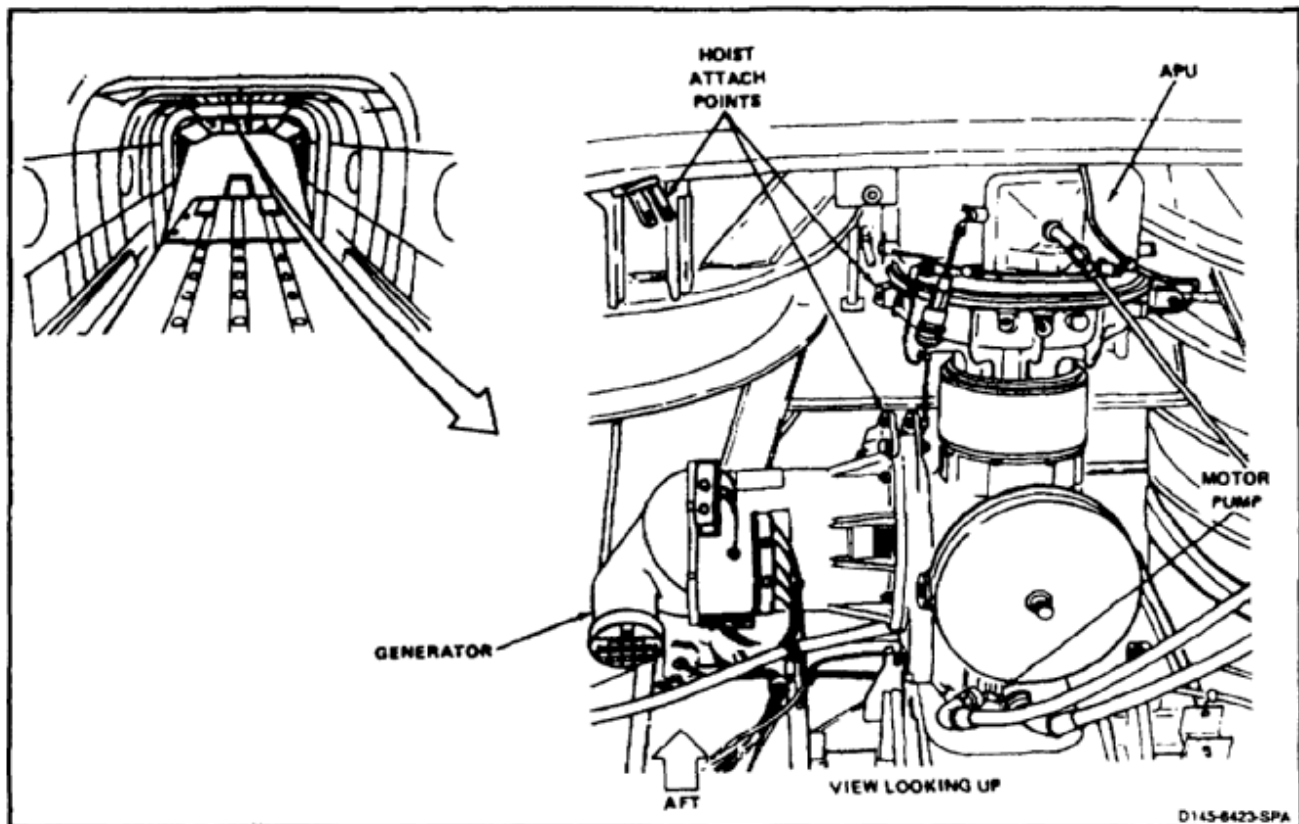

**NOTE**

Ensure APU generator wires are properly tagged as the APU generator manufactures (Lucas and Leland) have different wire terminal attachment points.

1. Loosen two fasteners (1) and remove terminal cover (2). Tag and disconnect six wires (3) by removing six nuts (4) and washers (5). Tape wire ends. Use tape (E385).
2. Loosen two fasteners (6) and remove terminal cover (7). Tag and disconnect four wires (8) by removing four nuts (9) and washers (10). Tape wire ends. Use tape (E385).
3. Loosen two fasteners (11) and remove terminal cover (12). Tag and disconnect three wires (13) by removing three nuts (14) and washers (15). Tape wire ends. Use tape (E385).
4. Tag and disconnect drain hose (16) at auxiliary power unit (APU) (17). Use container and cloths (E135) for spilled fuel. Plug hose and cap fitting (18).
5. Deleted.
6. Tie motor-pump (21) out of way. Use twine (E433).

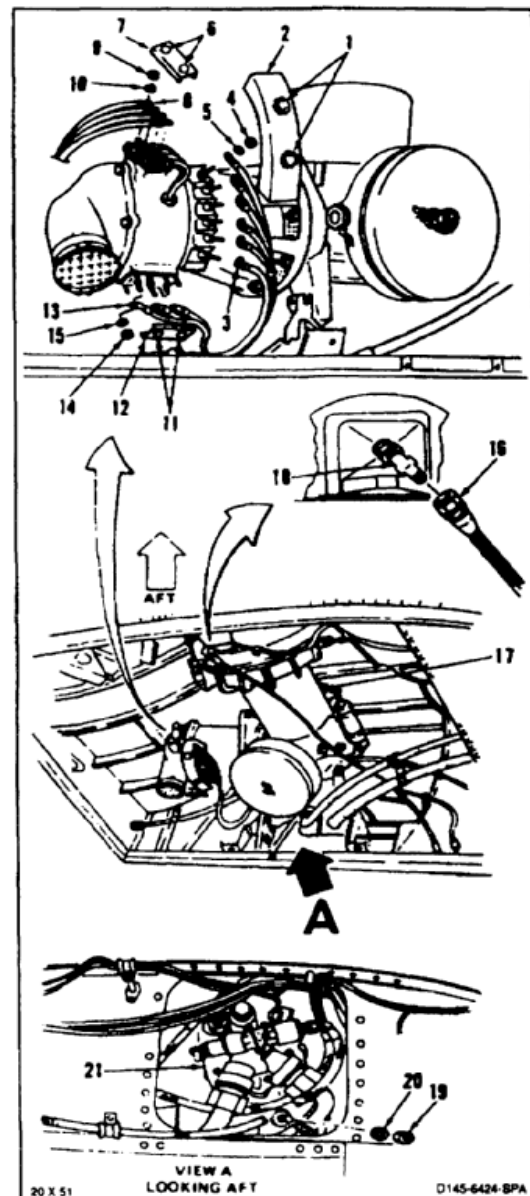

7. Remove nut (22), bolt (23), two washers (24), and washer (24.1). Remove link (25) from clevis (26).
8. Loosen clamp (27). Slide exhaust duct (28) aft.
- 8.1. Disconnect bonding jumper assembly (28.1).
9. Open quick-release clamp (29). Disconnect fuel hose at quick-disconnect fitting (30) on airframe bulkhead.
10. Tag and disconnect drain hose (31). Use tags (E264). Use container and cloths (E135) for spilled fuel. Plug hose and cap fitting (32).
11. Tag and disconnect vent hose (33). Use tags (E264).
12. Disconnect plug (34).

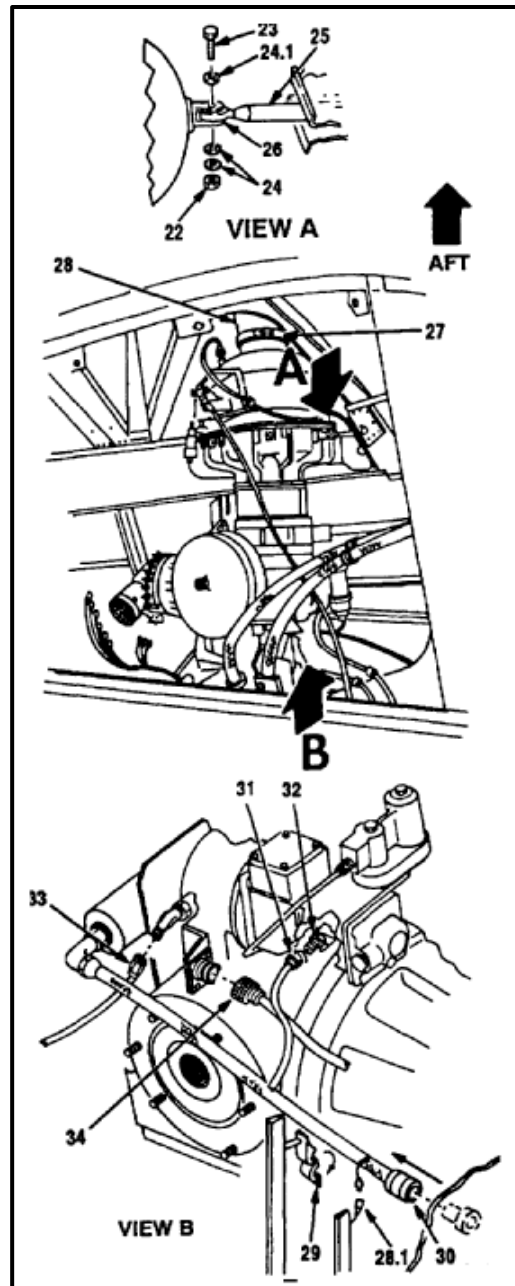



**NOTE**

Hoist operating instructions are marked on hoist.

13. Position lug (35) of hoist (36) in clevis (37) on structure (38). Install bolt (39) and nut (40).
14. Route cable (41) through tackle block (42). Hook tackle block to fitting (43) on structure (38).
15. Attach cable (41) to links (44) on APU (17) with bolt (45) and nut (46).

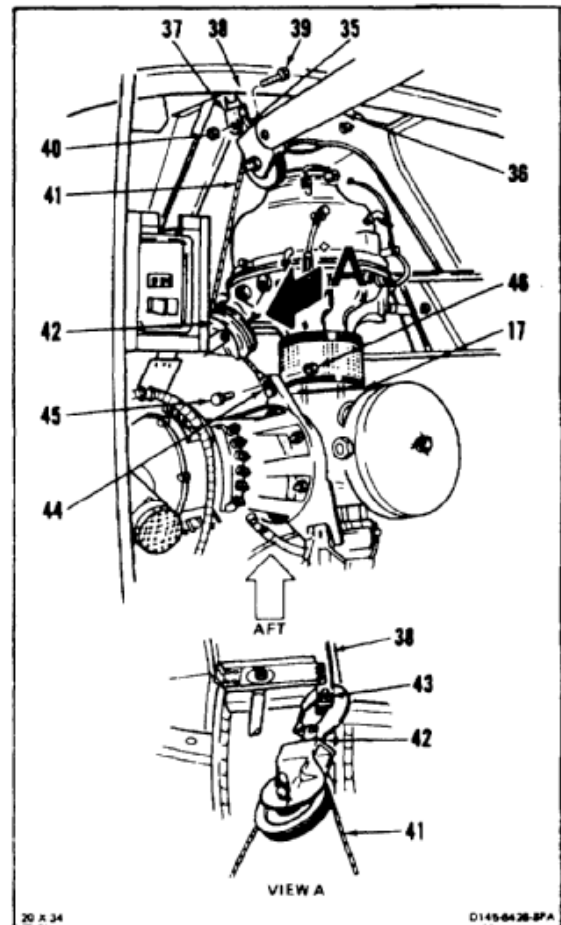
**WARNING**

Make sure slack is removed from hoist cable. Otherwise, APU could drop when it is disconnected causing injury to personnel.

16. Operate hoist (36) to remove slack from cable (41).

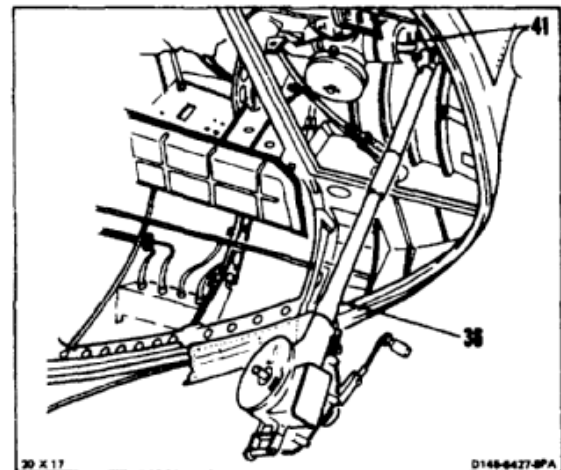

17. Remove lockwire and remove bolt (47), washer (48), and washer (48.1) from link (49).

**NOTE**

Do not remove bolt (51).

18. On right forward support (50), loosen aft bolt (51) and remove forward bolt (52) and washer (53). Rotate clip (54) away from adapter (55).
19. Repeat step 18 at left forward support (56).

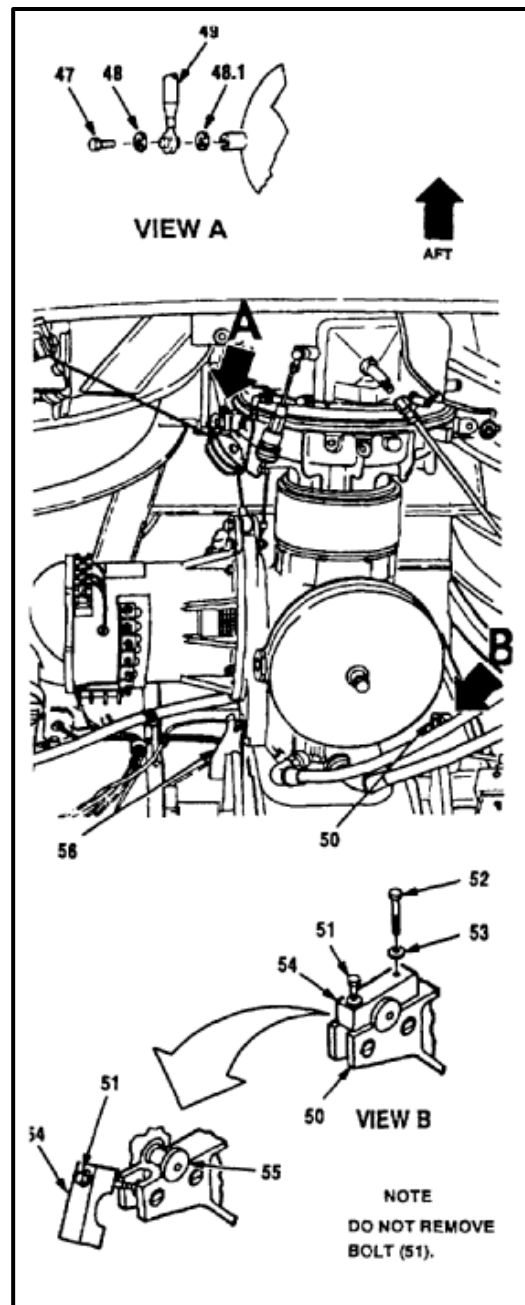

**15-3 REMOVE AUXILIARY POWER UNIT (APU) (Continued)**

15-3

20. Position trailer (57) near helicopter. Lay wood planks (58) across trailer. Position padded support (59) on planks.

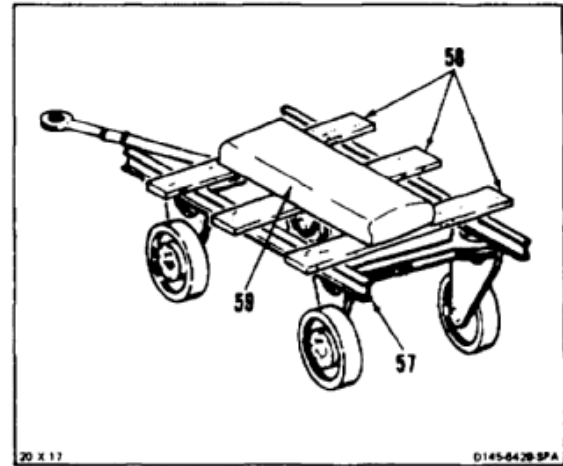

21. Operate hoist (36) to lower aft end of APU (17) below edge of structure (38). Make sure all lines, wires, and hoses are disconnected and out of way.

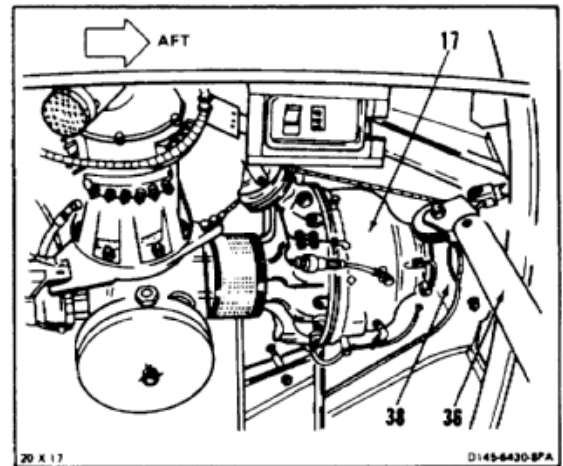

**WARNING**

When adapters are removed from supports, weight of APU will be supported by hoist only. APU is heavy and can injure personnel if it drops. APU must be supported by hoist and moved carefully to prevent injury to personnel.

22. Have helpers lift forward end of APU (17) to remove adapters (55) from left support (56) and right support (50). Have helpers keep APU steady.

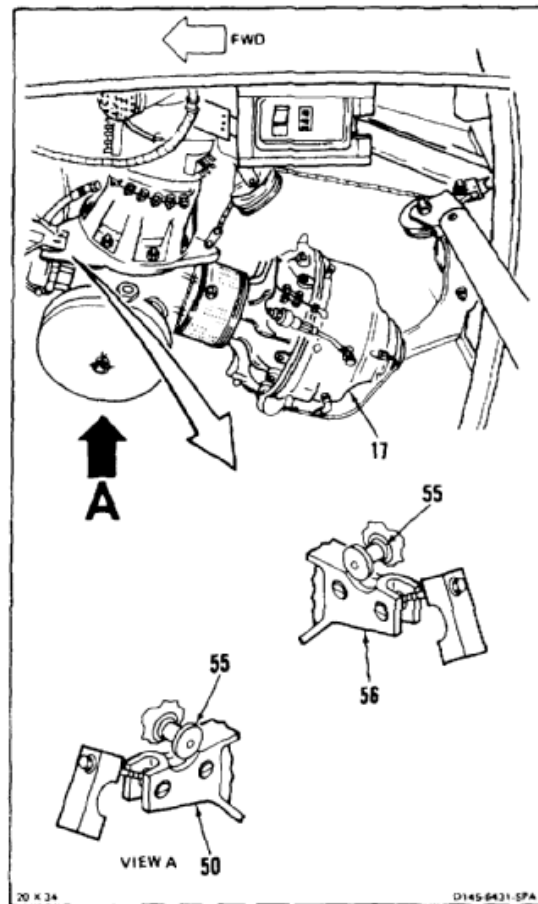

**CAUTION**

Do not let weight of APU crush its fittings, lines, or accessories.

23. With aid of helpers, operate hoist (36) and lower APU (17) onto trailer (57). Make sure APU does not crush its fittings, lines, or accessories.
24. Operate hoist (36) to remove tension from cable (41).
25. Remove bolt (45) and nut (46) to disconnect cable (41) from links (44) on APU (17).

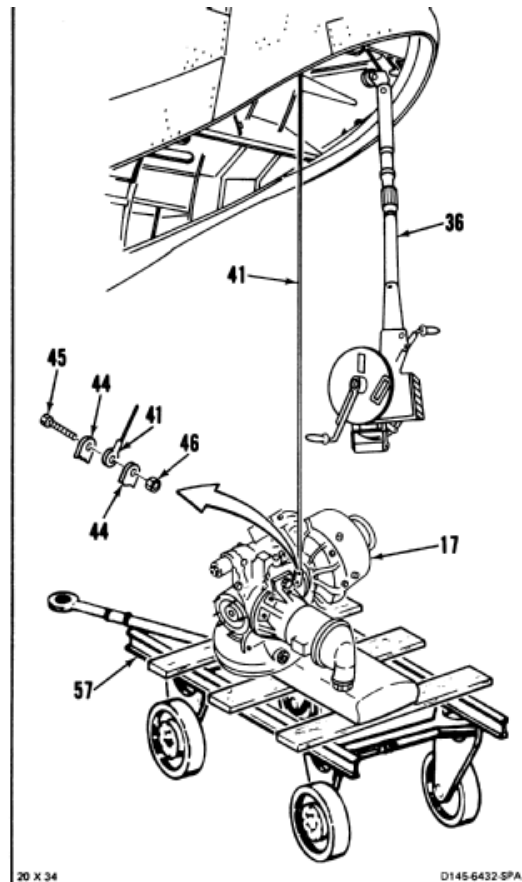

26. If APU (17) being replaced, do the following:
- Remove elbow (60) and packing (61). Remove nut (62) from elbow.
  - Remove lockwire and remove four bolts (63), washers (64), and two adapters (55).
  - Loosen clamp (65) and remove clamp and screen (66) from generator (67).
  - Remove lockwire and remove bolt (68) and clevis (26).
  - Remove bolt (69), nut (70), two washers (71), and links (44).
  - Loosen eight nuts (72). Rotate generator (67) counterclockwise and remove it. Remove eight nuts.

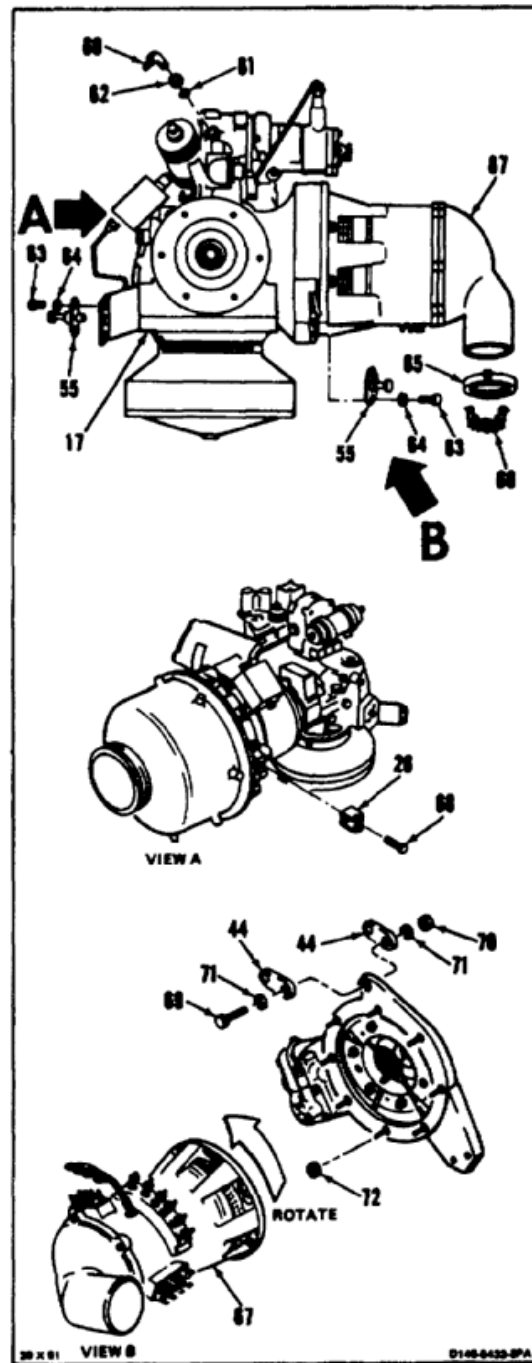
**FOLLOW-ON MAINTENANCE:**

None

END OF TASK

15-16

INITIAL SETUP

**Applicable Configurations:**

All

**Tools:**

Aircraft Mechanic's Tool Kit, NSN 5180-00-323-4692  
 Torque Wrench, 30 to 150 Inch-Pounds  
 Torque Wrench, 100 to 750 Inch-Pounds  
 Workstand  
 Bomb Hoist, T166

**Materials:**

Grease (E190)  
 Lockwire (E231)

**Parts:**

Bolt  
 Nut  
 Packing

**Personnel Required:**

Medium Helicopter Repairer (3)  
 Inspector

**References:**

TM 55-1520-240-23P

**General Safety Instructions:**

**WARNING**

All regulations and instructions for handling fuels shall be strictly observed.

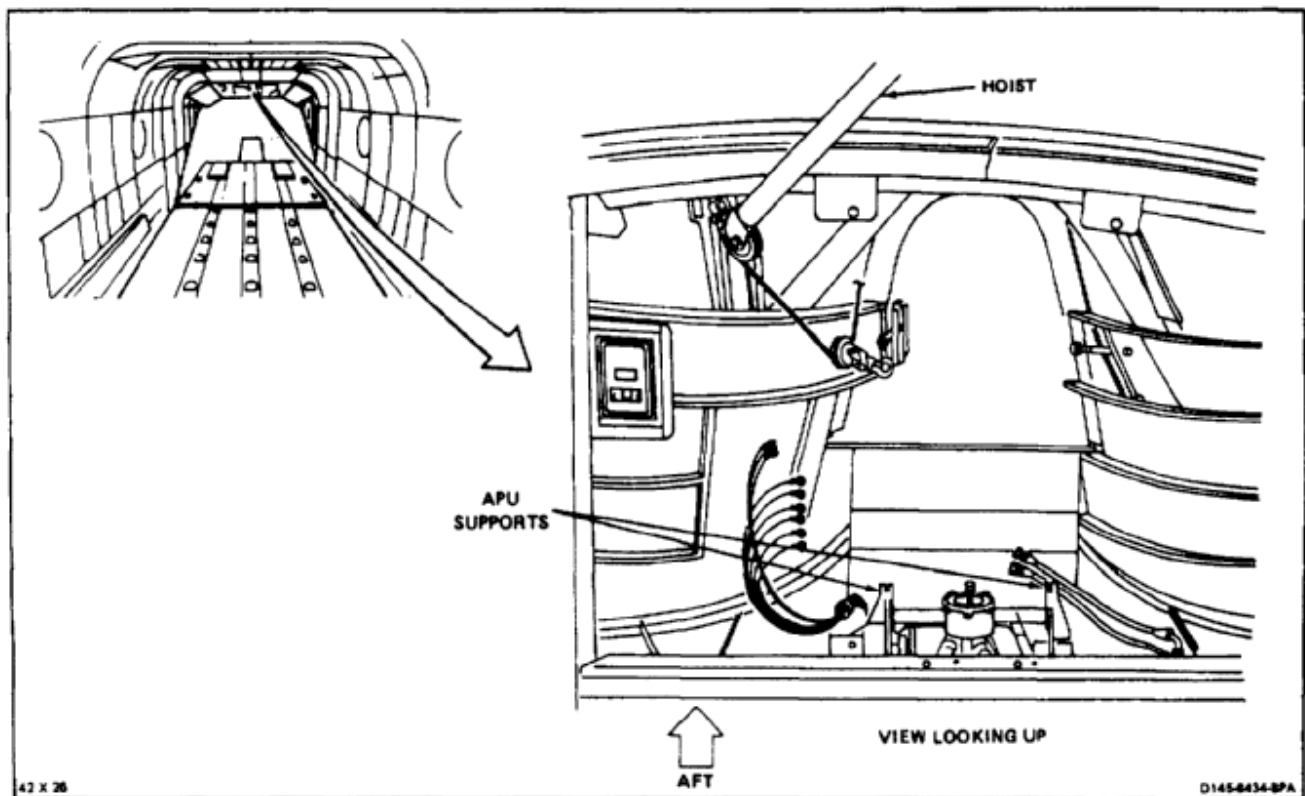

42 X 26

D145-8434-8PA

1. If auxiliary power unit (APU) (1) is not a replacement, go to step 2. If APU (1) is a replacement, do the following:
  - a. Apply grease (E190) to generator shaft (2).
  - b. Install eight nuts (3) loosely on studs (4). Install generator (5) over studs, large terminal board (6) down. Rotate generator clockwise. Tighten nuts.
  - c. Install two links (7), washers (8), bolt (9), and nut (10) on lug (11). Torque nut to **175 inch-pounds**.

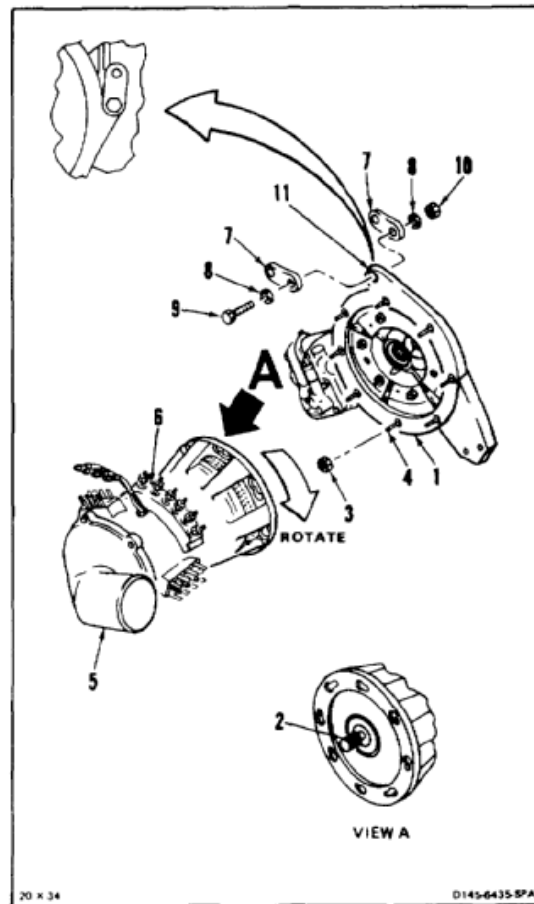



**15-4 INSTALL AUXILIARY POWER UNIT (APU) (Continued)**

15-4

- d. Install clevis (12) and bolt (13) on side of APU (1). Lockwire bolt to clevis. Use lockwire (E231).
- e. Install screen (14) on generator (5). Tighten clamp (15) over screen.
- f. Install two adapters (16), four bolts (17), and washers (18). Install lockwire (E231) on bolts.
- g. Install nut (19) on elbow (20). Install packing (21) and elbow.

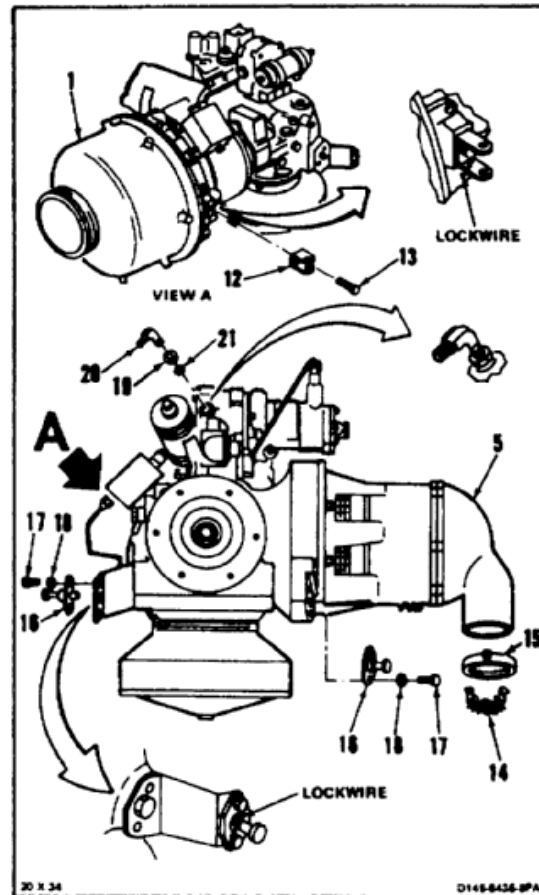
**INSPECT**

2. Attach cable (22) to links (7) on APU (1) with bolt (23) and nut (24).

**NOTE**

Hoist operating instructions are marked on hoist.

3. Operate hoist (25) to remove slack from cable (22).

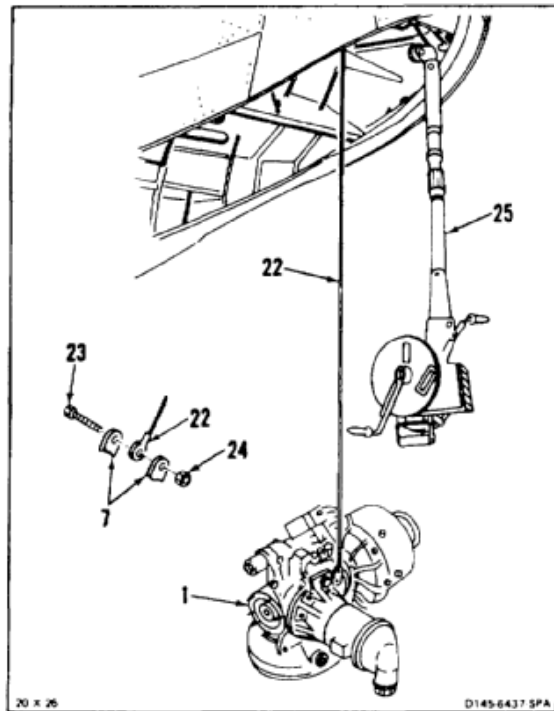

**WARNING**

APU is heavy and can injure personnel if it drops. APU must be supported by hoist and moved carefully to prevent injury to personnel.

4. Operate hoist (25) to raise APU (1) to supports (26 and 27). Make sure all lines, wires, and hoses are out of way. Have helpers keep APU steady.
5. Have helpers lift forward end of APU (1) to position adapters (16) in left support (26) and right support (27).

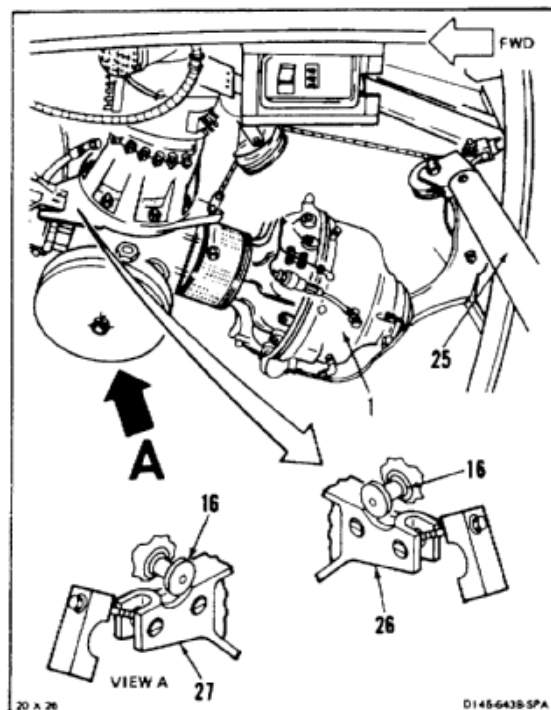

**15-4 INSTALL AUXILIARY POWER UNIT (APU) (Continued)**

15-4

6. Operate hoist (25) to raise aft end of APU (1) above edge of structure (28).

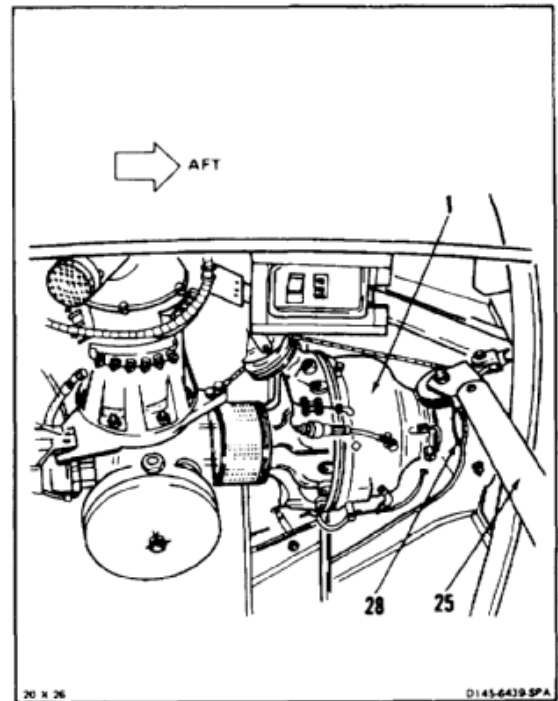

7. Align left link (29) with APU (1) and install bolt (30), washer (31), and washer (31.1). Torque bolt (30) to **75 to 85 inch-pounds**. Safety wire bolt (30). Use lockwire (E231).
8. Position link (32) in clevis (12) and install bolt (33), two washers (35), washer (35.1), and nut (34). Torque bolt (33) to **75 to 85 inch-pounds**.
9. On right forward support (27), position clip (36) over adapter (16). Install bolt (37) and washer (38). Torque bolts (37 and 39) to **75 to 85 inch-pounds**.
10. Repeat step 9 for left forward support (26).

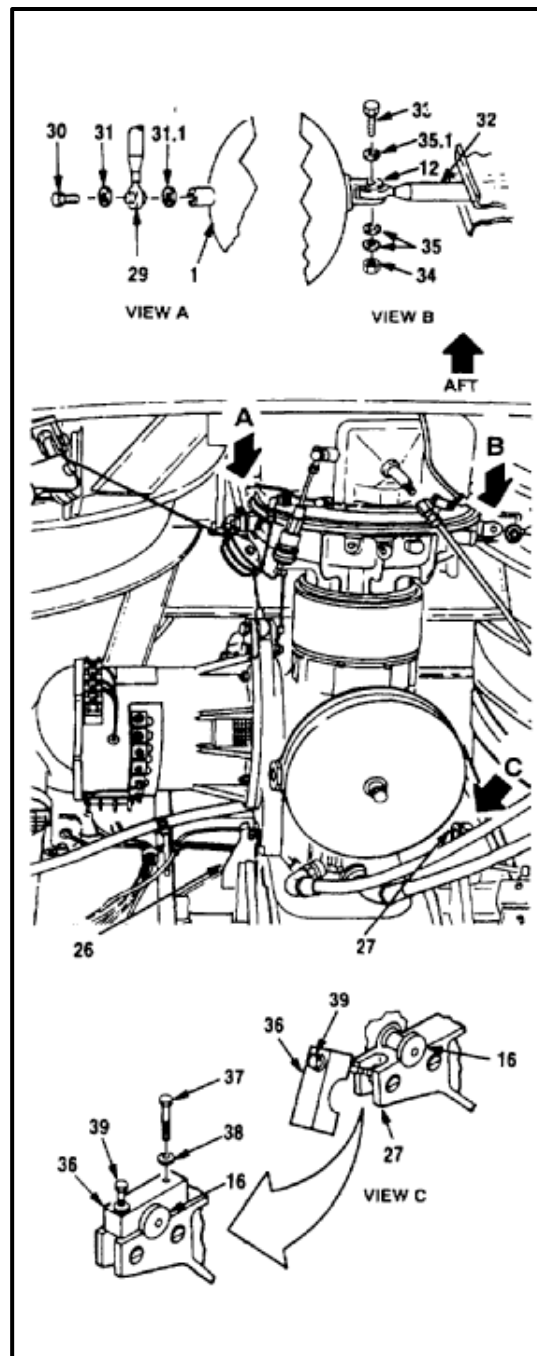

## 15-4 INSTALL AUXILIARY POWER UNIT (APU) (Continued)

15-4

11. Operate hoist (25) to remove tension from cable (22).
12. Remove bolt (23) and nut (24) to disconnect cable (22) from links (7).
13. Unhook tackle block (40) from fitting (41).
14. Remove bolt (42) and nut (43) to remove lug (44) from clevis (45). Remove hoist (25).

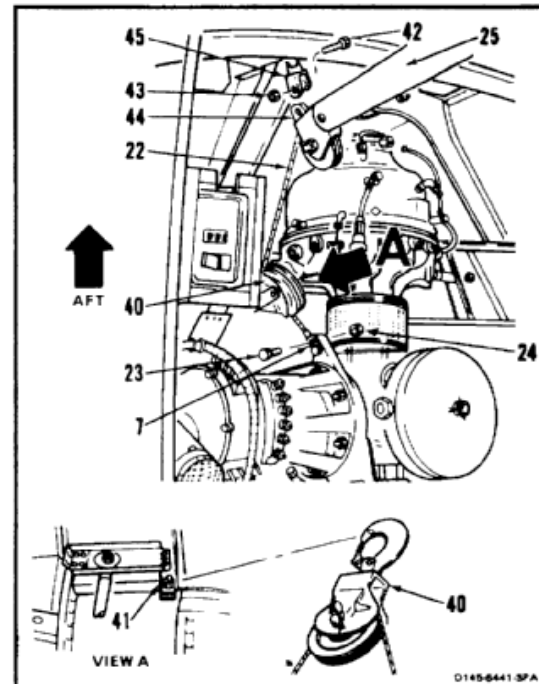

15. Slide exhaust duct (46) forward over APU (1). Check for **0.09 inch** minimum gap between duct (46) and tailcone closure (47.1) before tightening clamp (47). Tighten clamp (47).

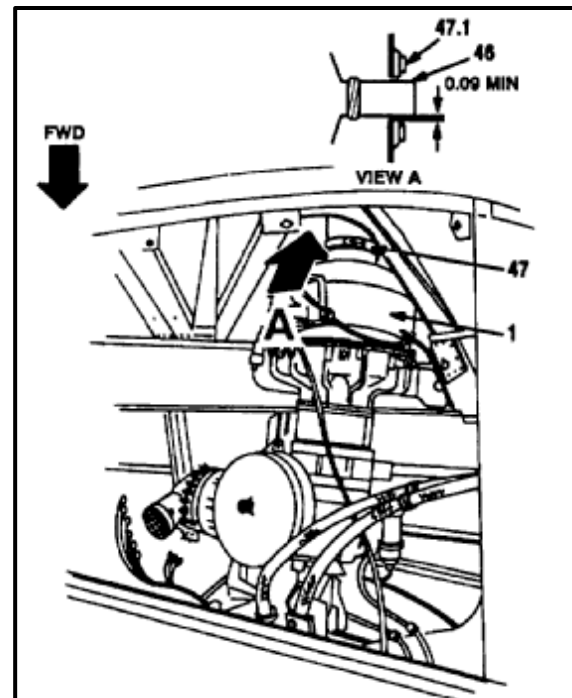

16. Connect plug (48).
17. Connect vent hose (49). Remove tag. Tighten nut (19).
18. Remove plug from drain hose (50) and cap from fitting (51). Connect hose to fitting. Remove tag.
19. Connect fuel hose at quick-disconnect fitting (52) on airframe bulkhead.
- 19.1. Connect bonding jumper assembly (52.1).
- 19.2. Install quick-release clamp (53) on hose. Close clamp and lock.
- 19.3. Loosen hose at APU and rotate fitting (53.1) counterclockwise toward the **12 o'clock** position to remove any slack in hose.
- 19.4. Tighten fitting (53.1). Use cloths (E135) for spilled fuel.
20. Deleted.

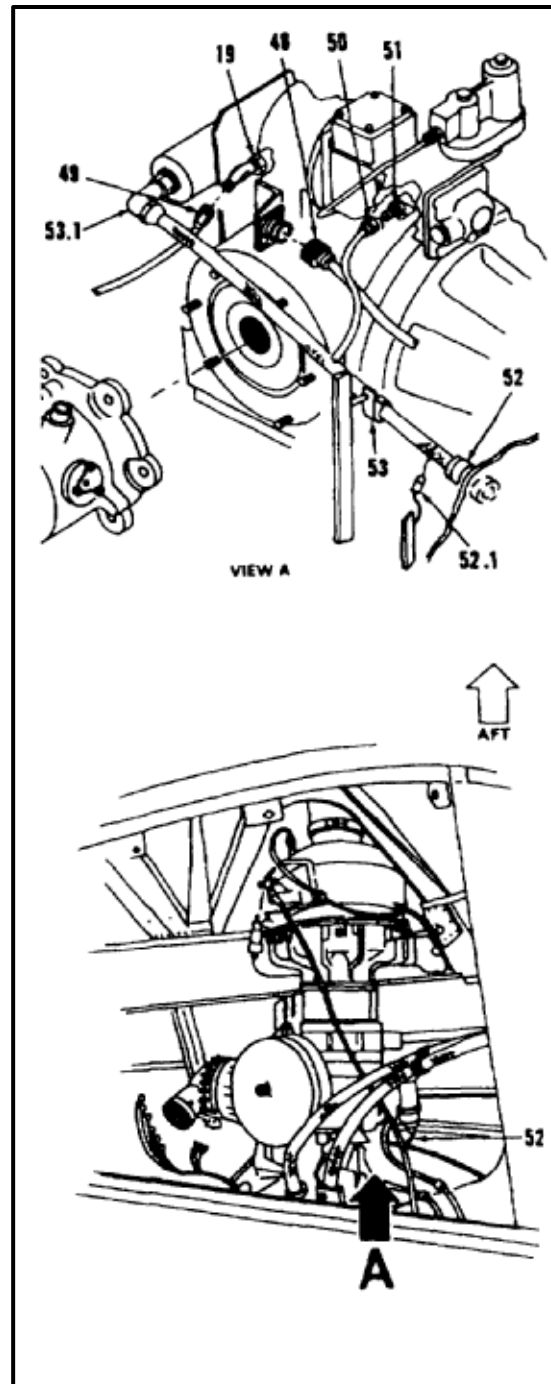

## 15-4 INSTALL AUXILIARY POWER UNIT (APU) (Continued)

15-4

21. Deleted.
22. Remove plug from drain hose (59) and cap from fitting (60). Connect hose to fitting. Remove tag.
23. Remove tape and connect three wires (61) to generator (5) by installing three nuts (62) and washers (63). Remove tags. Install terminal cover (64) and tighten two fasteners (65).
24. Remove tape and connect four wires (66) to generator (5) by installing four nuts (67) and washers (68). Remove tags. Install terminal cover (69) and tighten two fasteners (70).

**NOTE**

Ensure APU generator wires are properly tagged as the APU generator manufacturers (Lucas and Leland) have different wire terminal attachment points.

If Leland APU generator is installed, Lucas generator terminal board will not fit. Use rubber nipple (P/N MS25171-4S) (NSN 5975-00-553-7077) or equivalent.

25. Remove tape and connect six wires (71) to generator (5) by installing six nuts (72) and washers (73). Remove tags. Install terminal cover (74) and tighten two fasteners (75).

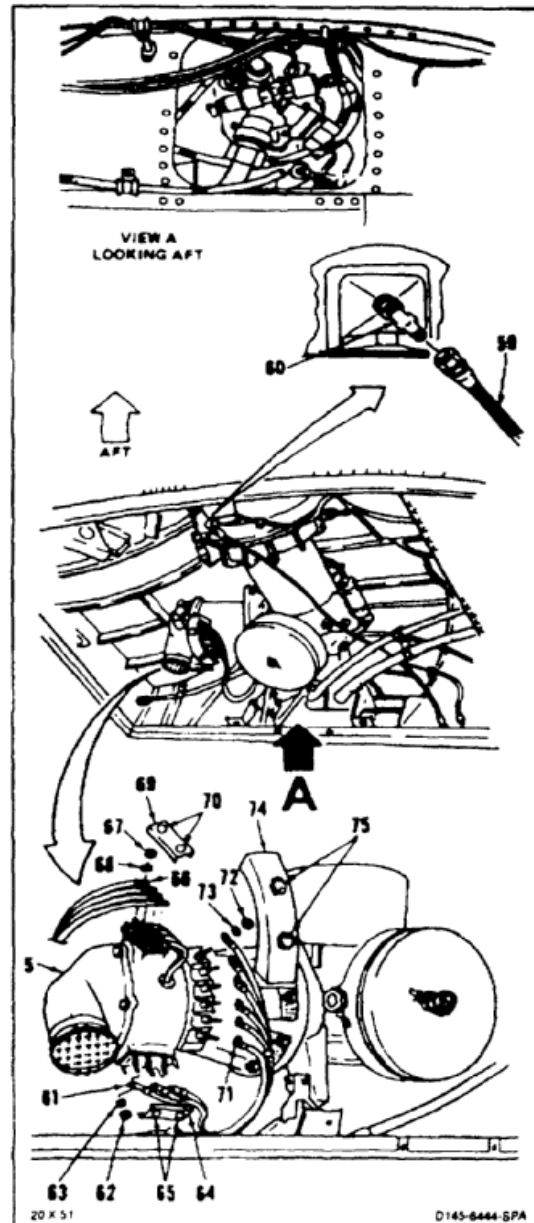
**FOLLOW-ON MAINTENANCE:**

- Install APU motor pump (Task 7-147).
- Service auxiliary power unit (Task 1-53).
- Perform operational check of APU (TM 55-1520-240-T).
- Install APU drip pan (Task 2-3).
- Install aft transmission drip pan (Task 2-3).
- Close aft transmission access panels (Task 2-2).
- Close ramp work platform (Task 2-2).
- Close cargo ramp (TM 55-1520-240-T).

END OF TASK

INITIAL SETUP

**Applicable Configurations:**

All

**Tools:**

Aircraft Inspection Tool Kit, NSN 5180-00-323-5114  
Workstand

**Materials:**

None

**Personnel Required:**

Medium Helicopter Mechanic (2)  
Inspector

**Equipment Condition:**

Battery Disconnected (Task 1-39)  
Electrical Power Off  
Hydraulic Power Off  
Ramp open and Level (TM 55-1520-240-T)  
APU Drip Pan Removed (Task 2-3)

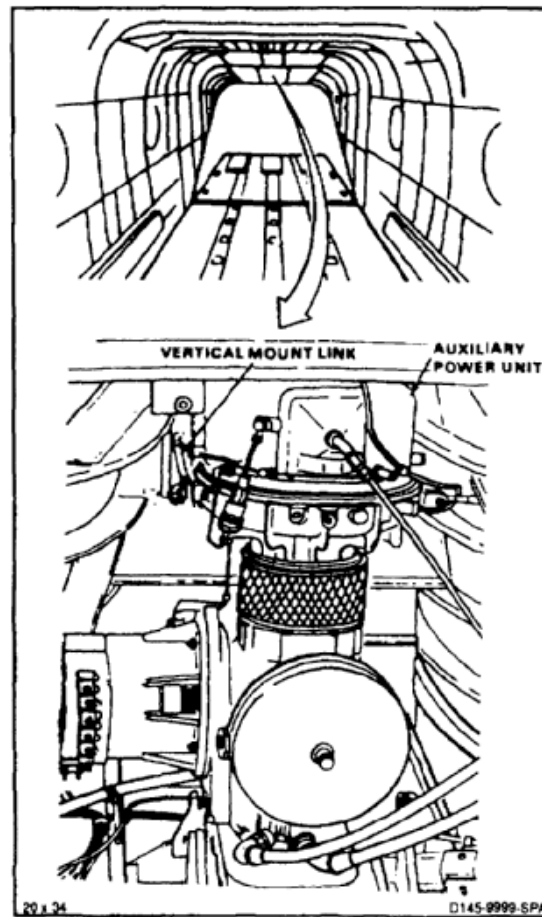



**15-5 INSPECT APU AFT MOUNTS (Continued)**

15-5

1. Have helper push up on APU (1) under vertical mount link (2) until all slack is taken up. Move APU from side to side as far as it will go.
2. Measure total travel of exhaust duct (3) in exhaust closure (4). Total side to side or vertical measurement shall not exceed **1/8 inch**. If measurement exceeds **1/8 inch**, check vertical mount link (2) and lateral mount link (5) for wear.

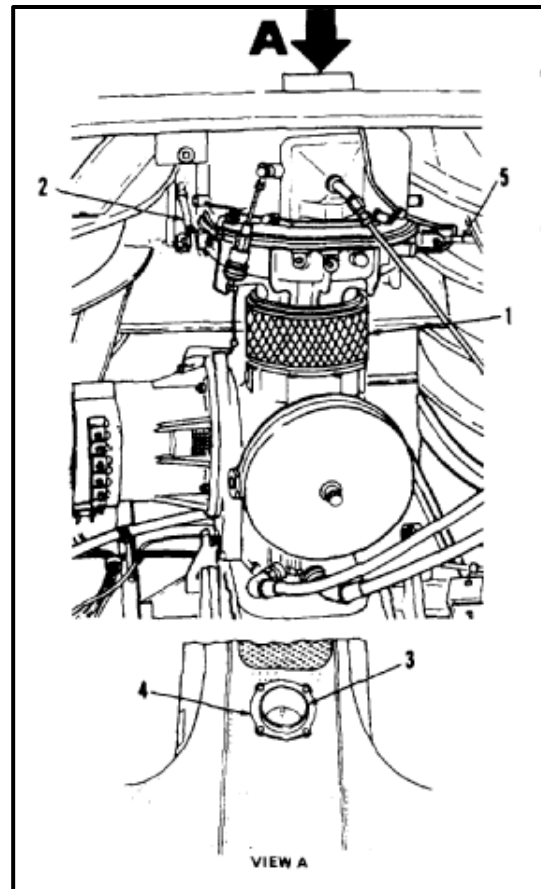
**FOLLOW-ON MAINTENANCE:**

None

END OF TASK

## INITIAL SETUP

**Applicable Configurations:**

All

**Tools:**

Aircraft Mechanic's Tool Kit, NSN 5180-00-323-4692  
 Bomb Hoist, Aero 14C  
 Tackle Block, 114E6058-23  
 Workstand

**Materials:**

None

**Parts:**

Bolt (2)  
 Nut (2)

**Personnel Required:**

Medium Helicopter Repairer (2)

**Equipment Condition:**

Battery Disconnected (Task 1-39)  
 Electrical Power Off  
 Hydraulic Power Off  
 Cargo Ramp Open and Level (TM 55-1520-240-T)  
 Ramp Work Platform Opened (Task 2-2)  
 APU Drip Pan Removed (Task 2-3)

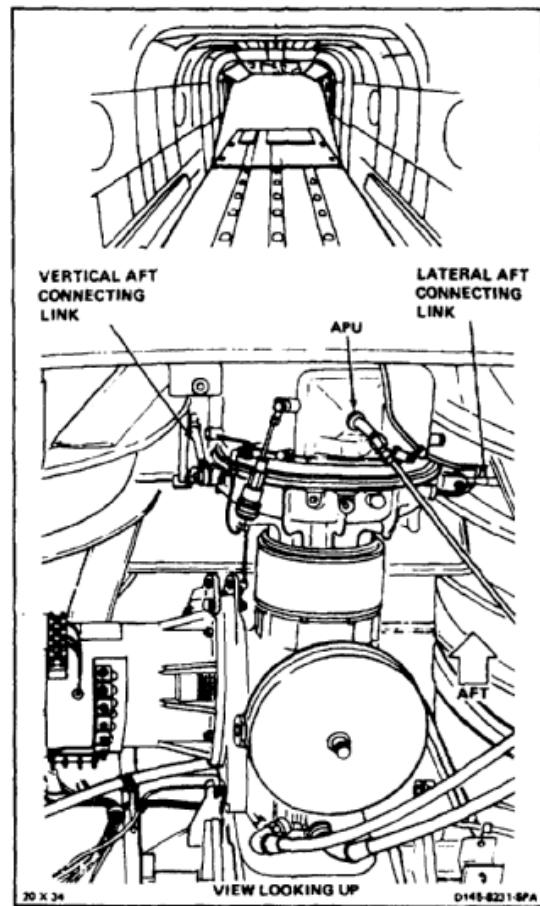

**REMOVE APU HORIZONTAL AFT MOUNT  
CONNECTING LINK**

1. Remove nut (1), bolt (2), and three washers (3).  
Remove link (4) from clevis (5).
2. Remove nut (6), bolt (7), and two washers (8).  
Remove link (4) from fitting (9).
3. Loosely install bolt (7), washers (8), and nut (6)  
in fitting (9).

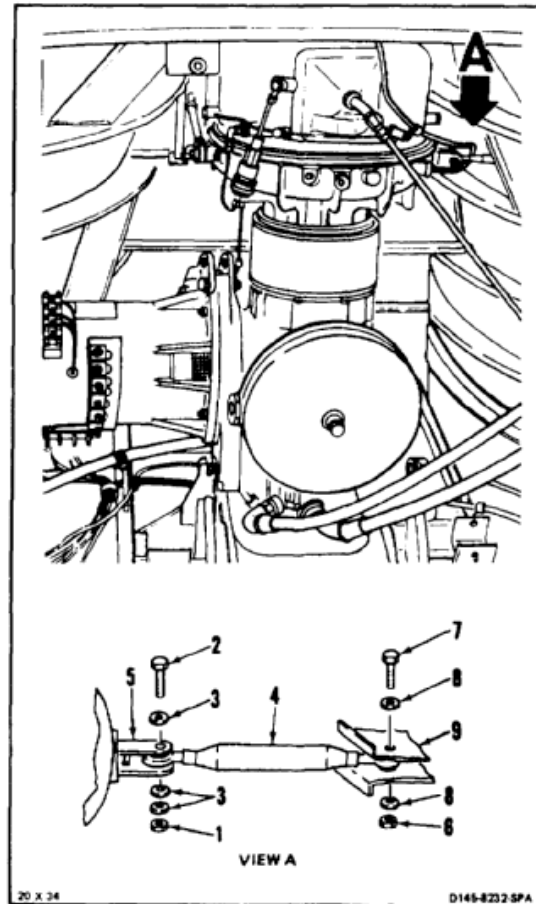

**REMOVE APU VERTICAL MOUNT CONNECTING LINK**

**NOTE**

Hoist operating instructions are marked on hoist.

4. Position lug (10) of hoist (11) in devis (12) on structure (13). Install bolt (14) and nut (15).
5. Route cable (16) through tackle block (17). Hook tackle block to fitting (18) on structure (13).
6. Attach cable (16) to links (19) on APU (20) with bolt (21) and nut (22).

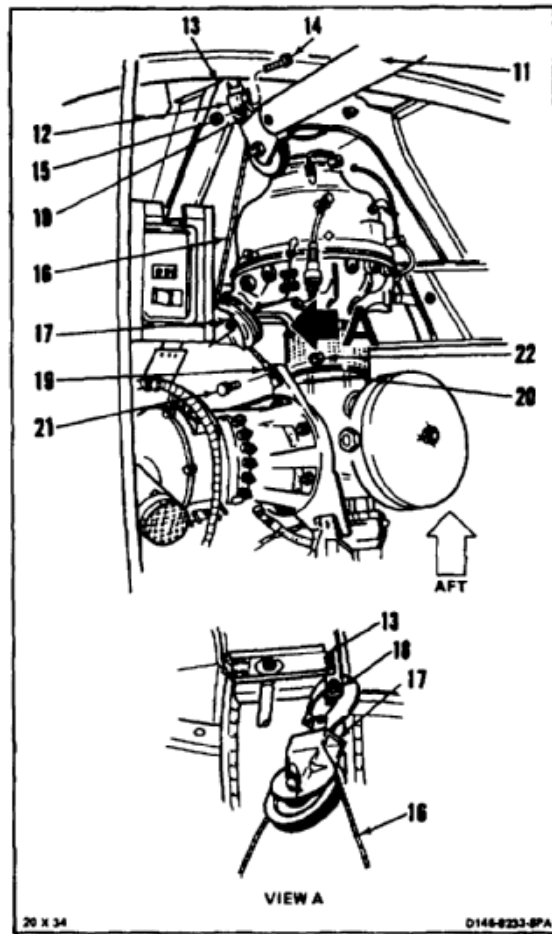

**WARNING**

Make sure slack is removed from hoist cable. Otherwise, APU could drop when vertical connecting link is disconnected causing injury to personnel.

7. Have helper operate hoist (11) to remove slack from cable (16).

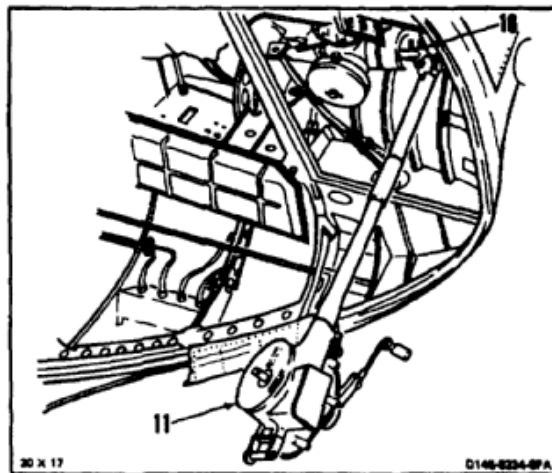

**15-6 REMOVE APU AFT MOUNT CONNECTING LINKS (Continued)**

15-6

8. Remove lockwire. Remove bolt (23) and washer (24) from link (25).
9. Remove nut (26), bolt (27), and two washers (28) from fitting (29). Remove link (25).
10. Loosely install bolt (27), washers (28), and nut (26) in fitting (29).

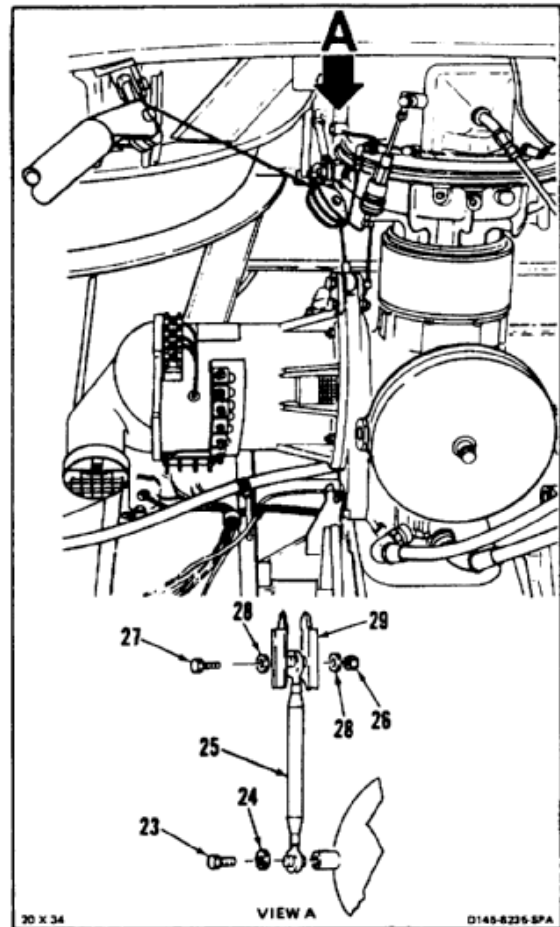
**FOLLOW-ON MAINTENANCE:**

None

END OF TASK

INITIAL SETUP

**Applicable Configurations:**

All

**Tools:**

Aircraft Mechanic's Tool Kit, NSN 5180-00-323-4692  
Workstand

**Materials:**

Lockwire (E231)

**Personnel Required:**

Medium Helicopter Mechanic (2)  
Inspector

**References:**

TM 55-1520-240-23P

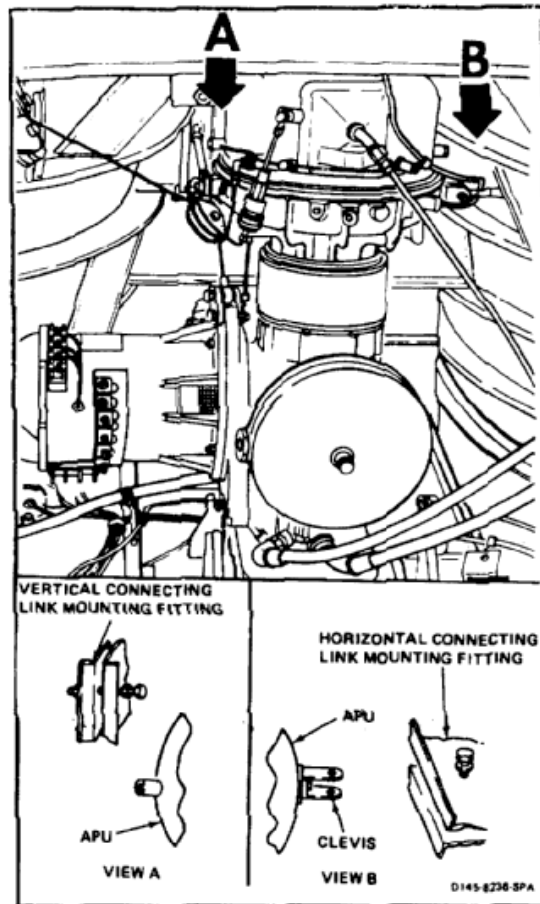

**INSTALL APU VERTICAL AFT MOUNT CONNECTING LINK**

**NOTE**

Two bushings are installed in fitting for link alignment.

1. Remove nut (1), bolt (2), two washers (3), and washer (3.1) from fitting (4).
2. Position link (5) in fitting (4). Install bolt (2), washer (3.1), two washers (3), and nut (1).
3. Align link (5) with APU mount point (6). Install (7), washer (8), and washer (8.1). Torque bolt (7) to **75 to 85 inch-pounds**.
4. Lockwire bolt (7). Use lockwire (E231).

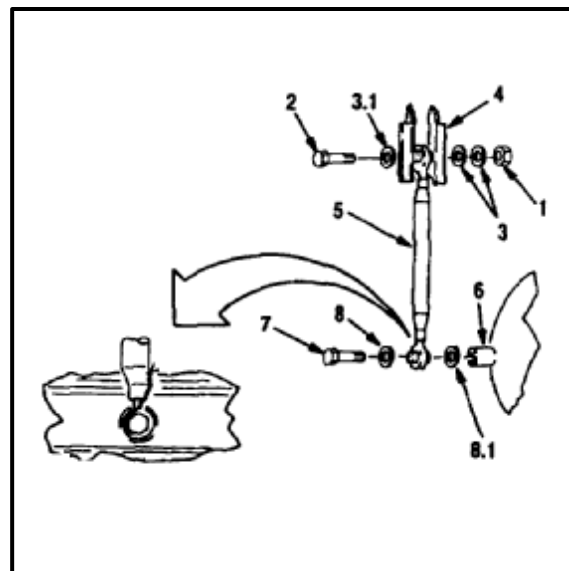

**INSTALL APU HORIZONTAL AFT MOUNT CONNECTING LINK****NOTE**

Two bushings are installed in fitting for link alignment.

5. Remove nut (9), bolt (10), two washers (11), and washer (11.1) from fitting (12).
6. Position link (13) in fitting (12). Install bolt (10), washer (11.1), two washers (11), and nut (9).
7. Position link (13) in clevis (14). Install bolt (15), two washers (16), washer (16.1), and nut (17).

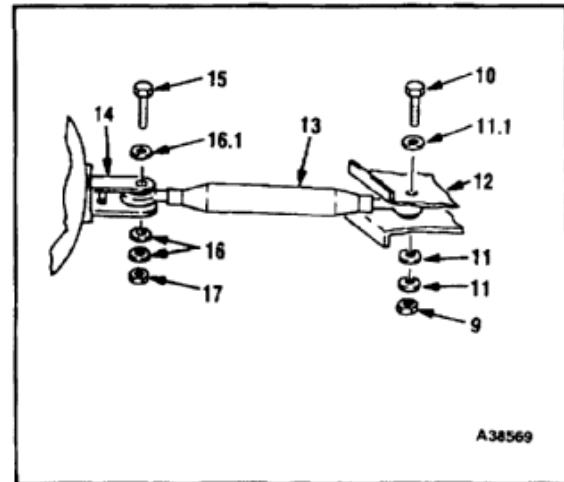

8. Have helper operate hoist (18) to remove tension from cable (19).
9. Remove bolt (20) and nut (21) to disconnect cable (19) from links (22).
10. Unhook tackle block (23) from fitting (24).
11. Remove bolt (25) and nut (26) from lug (27) and clevis (28). Remove hoist (18).

**INSPECT****FOLLOW-ON MAINTENANCE:**

- Install APU drip pan (Task 2-3).
- Close ramp work platform (Task 2-2).
- Close cargo ramp (TM 55-1520-240-T).

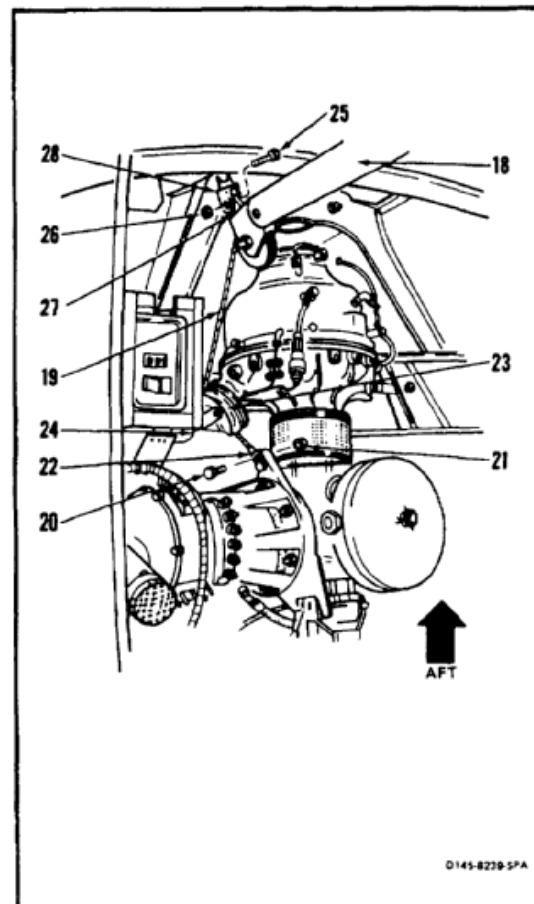

END OF TASK

INITIAL SETUP

**Applicable Configurations:**

All

**Tools:**

- Aircraft Mechanic's Tool Kit, NSN 5180-00-323-4692
- Bomb Hoist, Aero 14C (T166)
- Tackle Block (T165)
- Workstand

**Materials:**

Lockwire (E231)

**Parts:**

- Bolts (2)
- Nuts (2)

**Personnel Required:**

Medium Helicopter Repairer (2)

**Equipment Condition:**

- Battery Disconnected (Task 1-39)
- Electrical Power Off
- Hydraulic Power Off
- Cargo Ramp Open and Level (TM 55-1520-240-T)
- Ramp Work Platform Open (Task 2-2)
- APU Drip Pan Removed (Task 2-3)

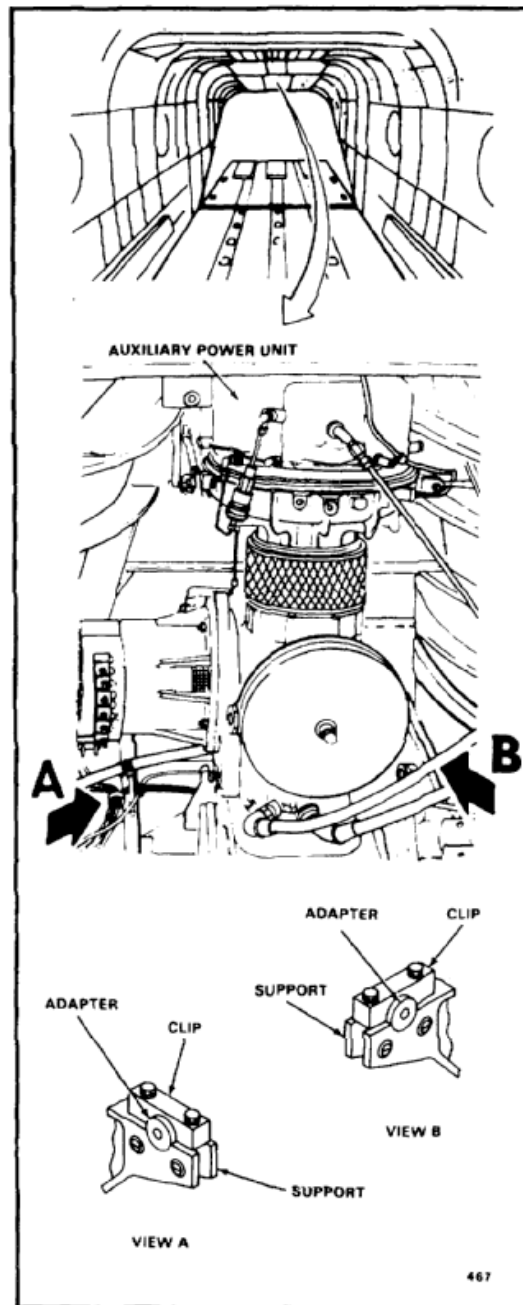



**15-7.1 REPLACE APU FORWARD MOUNTS (Continued)****15-7.1**

1. Loosen clamp (1). Slide exhaust duct (2) aft.

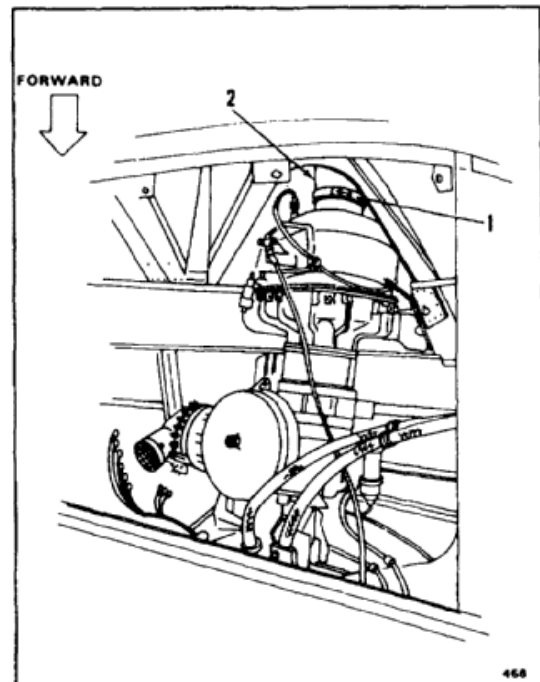

**NOTE**

Hoist operating instructions are marked on hoist.

2. Position lug (3) of hoist (4) in clevis (5) on structure (6). Install bolt (7) and nut (8).
3. Route cable (9) through tackle block (10). Hook tackle block to fitting (11) on structure (6).
4. Attach cable (9) to links (12) on APU (13) with bolt (14) and nut (15).

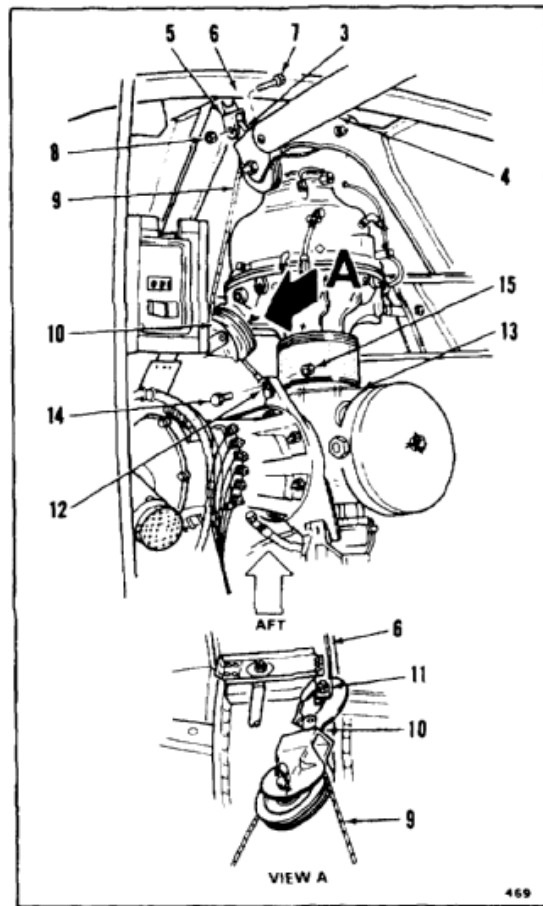

**WARNING**

Make sure slack is removed from hoist cable. Otherwise, APU could drop when it is disconnected causing injury to personnel.

5. Have helper operate hoist (4) to remove slack from cable (9).

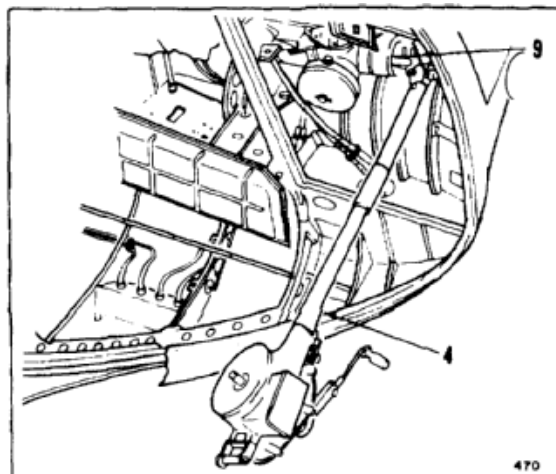

## 15-7.1 REPLACE APU FORWARD MOUNTS (Continued)

15-7.1

6. Remove nut (16), bolt (17), two washers (18), and washer (18.1). Remove link (19) from clevis (20).
7. Remove lockwire and remove bolt (21), washer (22), and washer (22.1) from link (23).
8. On right forward support (24), loosen aft bolt (25) and remove forward bolt (26) and washer (27). Rotate clip (28) away from adapter (29).
9. Repeat step 8 at left forward support (30).

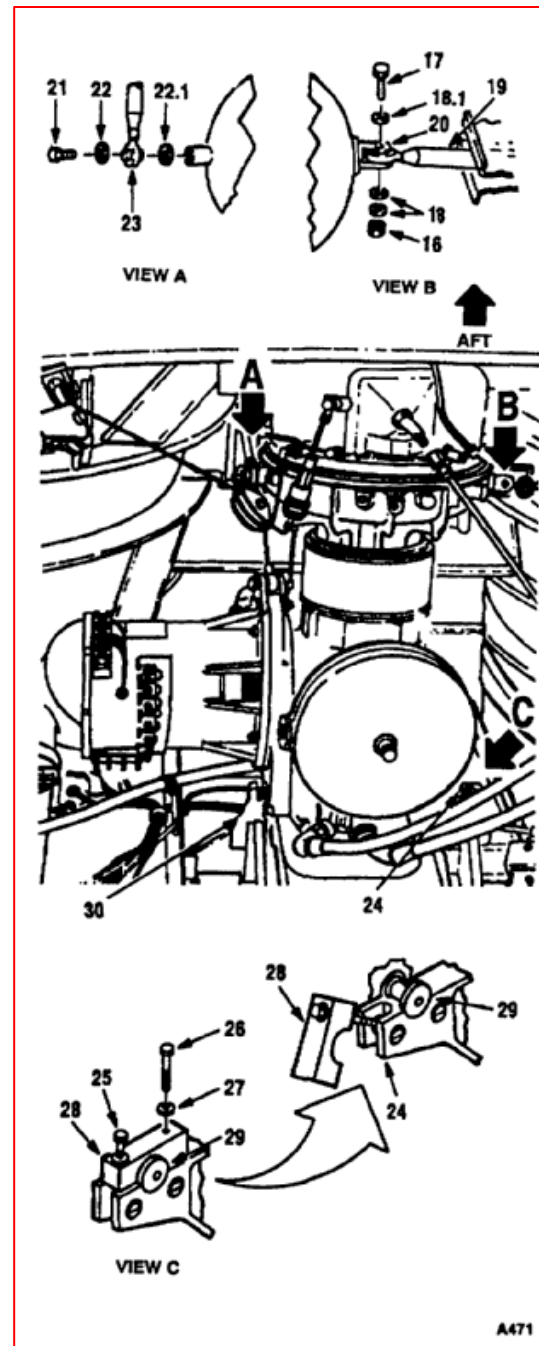

**WARNING**

When adapters are removed from supports, weight of APU will be supported by hoist only. APU is heavy and can injure personnel if it drops. APU must be supported by hoist and moved carefully to prevent injury to personnel.

**CAUTION**

Do not let weight of APU crush its fittings, lines, or accessories.

10. Have helpers lift forward end of APU (13) to remove adapters (29) from left support (30) and right support (24). Have helpers keep APU steady.
11. Remove lockwire and remove four bolts (31), washers (32), and two adapters (29).
12. Install two new adapters (29), four bolts (31), and washers (32). Install lockwire (E231) on bolts.

**WARNING**

APU is heavy and can injure personnel if it drops. APU must be supported by hoist and moved carefully to prevent injury to personnel.

13. Have helpers lift forward end of APU (13) to position adapters (29) in left support (30) and right support (24).

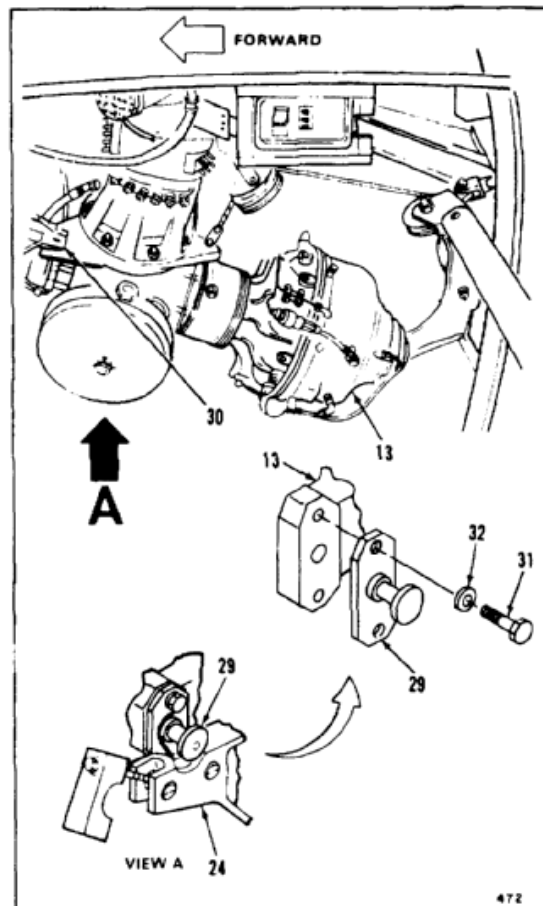

## 15-7.1 REPLACE APU FORWARD MOUNTS (Continued)

15-7.1

14. Align left link (23) with APU (13) and install bolt (21), washer (22), and washer (22.1). Torque bolt (21) to **75 to 85 inch-pounds**. Lockwire bolt. Use lockwire (E231).
15. Position link (19) in clevis (20) and install bolt (17), nut (16), two washers (18), and washer (18.1).
16. On right forward support (24), position clip (28) over adapter (29). Install bolt (26) and washer (27). Tighten bolts (26 and 25).
17. Repeat step 16 for left forward support (30).

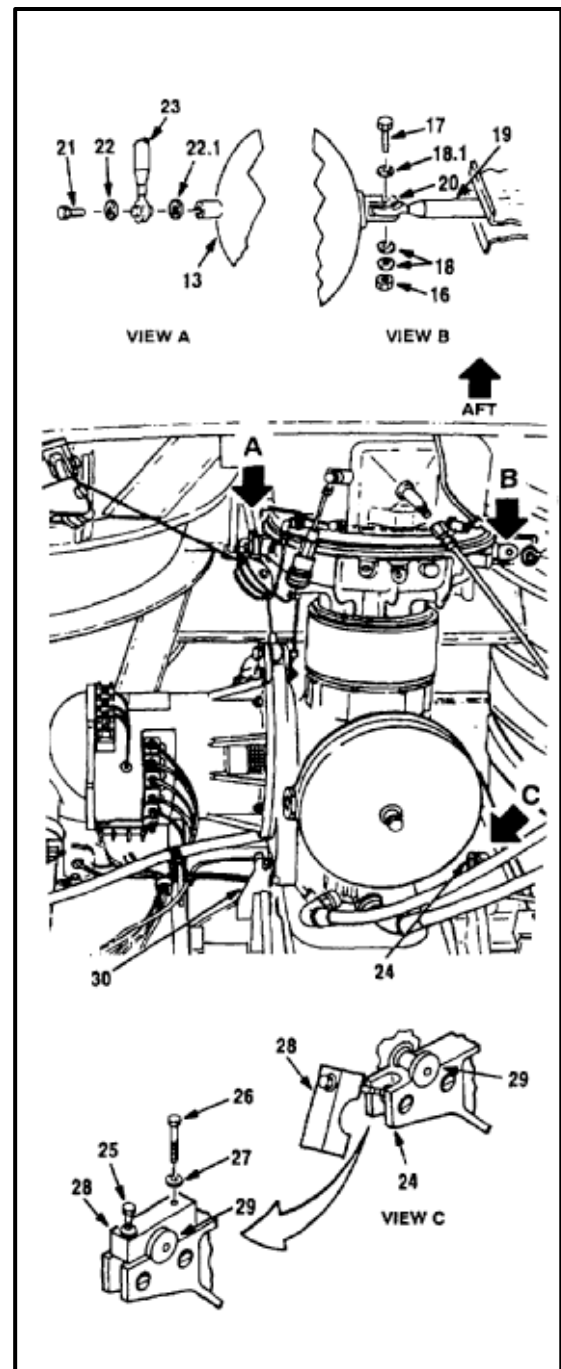

18. Operate hoist (4) to remove tension from cable (9).
19. Remove bolt (14) and nut (15) to disconnect cable (9) from links (12).
20. Unhook tackle block (10) from fitting (11).
21. Remove bolt (7) and nut (8) to remove lug (3) from clevis (5). Remove hoist (4).

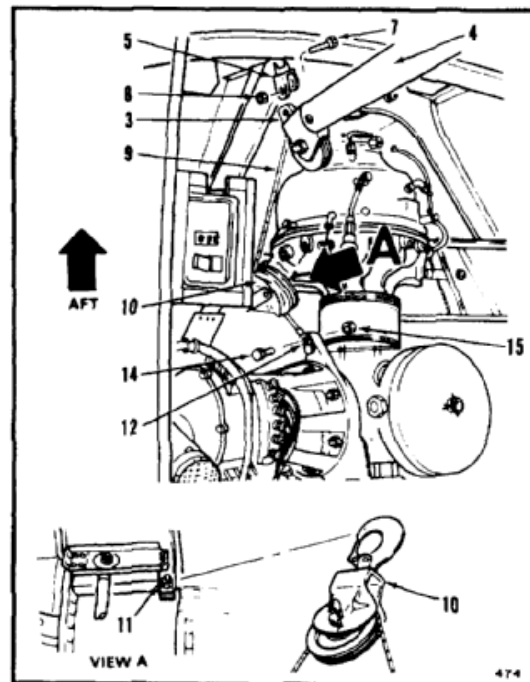

22. Slide exhaust duct (2) forward over APU (13). Check for **0.09 inch** minimum gap between duct (2) and tailcone closure (31). Tighten clamp (1).

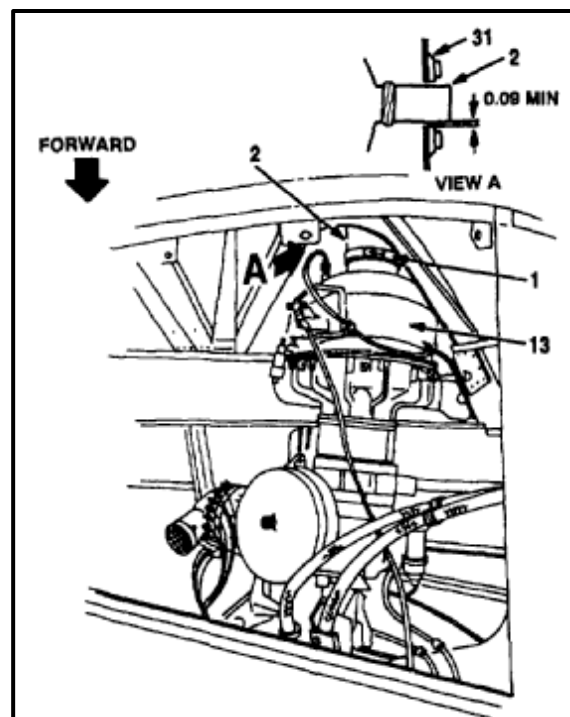

#### **FOLLOW-ON MAINTENANCE:**

- Perform operational check of APU (TM 55-1520-240-T).
- Install APU drip pan (Task 2-3).
- Install aft transmission drip pan (Task 2-3).
- Close aft transmission access panels (Task 2-2).
- Close ramp work platform (Task 2-2).
- Close cargo ramp (Task 2-2).

END OF TASK

**15-8 REMOVE APU EXHAUST DUCT CLOSURE**

15-8

**INITIAL SETUP****Applicable Configurations:**

All

**Tools:**

Aircraft Mechanic's Tool Kit, NSN 5180-00-323-4692  
Workstand

**Materials:**

None

**Personnel Required:**

Medium Helicopter Repairer

**Equipment Condition:**

Battery Disconnected (Task 1-39)  
Electrical Power Off  
Cargo Ramp Open and Level (TM 55-1520-240-T)  
Ramp Work Platform Open (Task 2-2)  
APU Drip Pan Removed (Task 2-3)

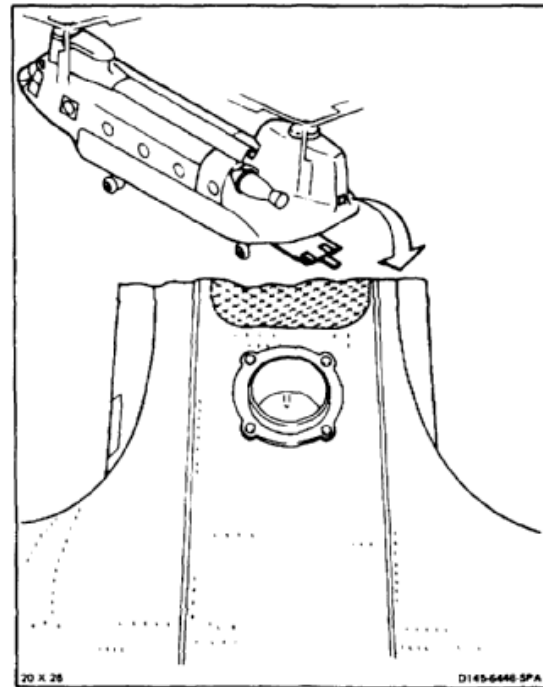

1. From inside helicopter, remove four nuts (1) and washers (2).
2. From outside helicopter, remove closure (3) and gasket (4).

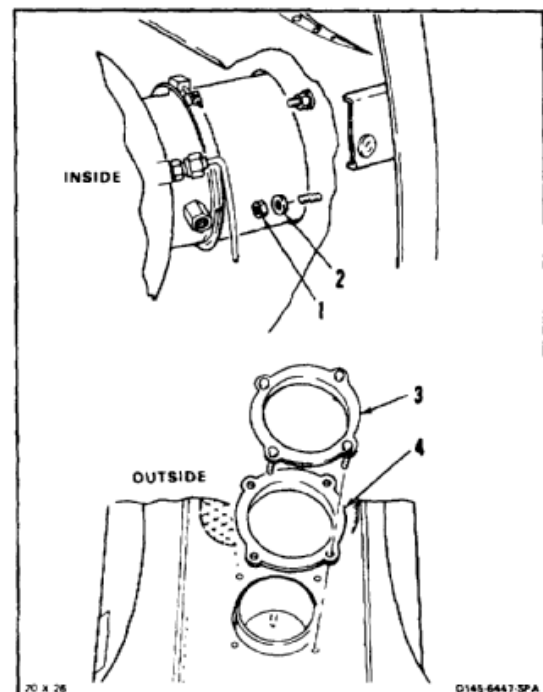
**FOLLOW-ON MAINTENANCE:**

None

END OF TASK

## INITIAL SETUP

**Applicable Configurations:**

All

**Tools:**

Aircraft Mechanic's Tool Kit, NSN 5180-00-323-4692  
Workstand

**Materials:**

None

**Personnel Required:**

Medium Helicopter Repairer  
Inspector

**References:**

TM 55-1520-240-23P

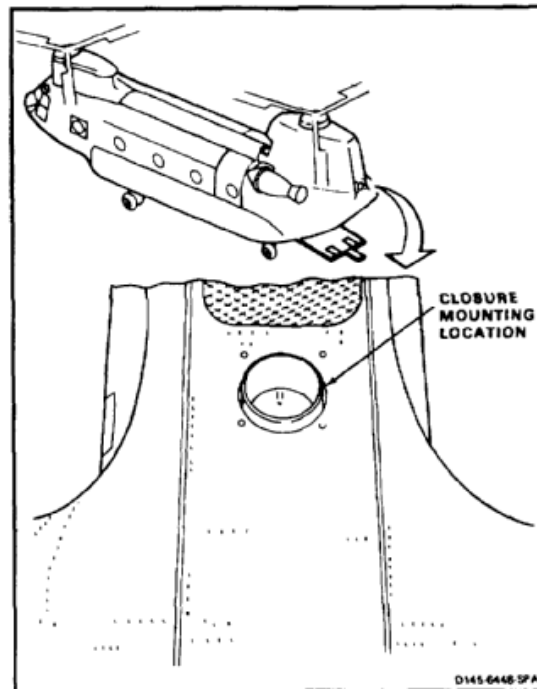

1. Install gasket (1) on closure (2).
2. From outside helicopter, install closure (2) over exhaust duct (3).
3. From inside helicopter, install four nuts (4) and washers (5) on screws (6).
4. Check for **0.09 inch** minimum gap between duct (3) and tailcone closure (2).

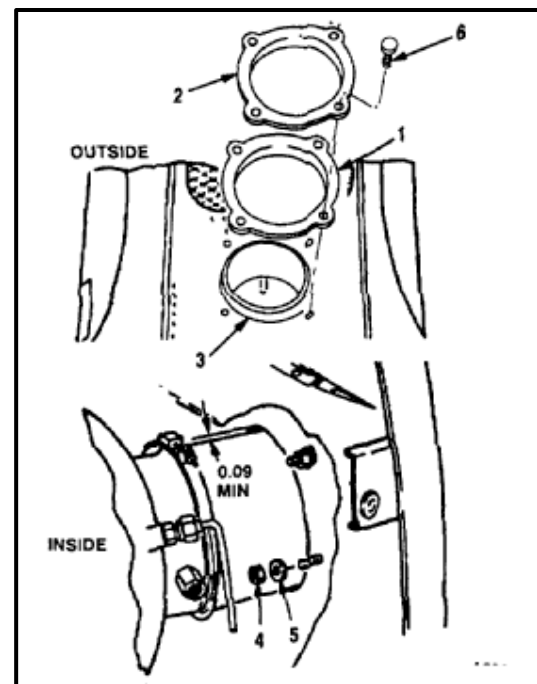
**FOLLOW-ON MAINTENANCE:**

Install APU drip pan (Task 2-3).  
Close ramp work platform (Task 2-2).  
Close cargo ramp (Task 2-2).

END OF TASK



# **CHAPTER 16**

## **MISSION EQUIPMENT**

### **SECTION I**

#### **CARGO CARRYING HOOK SYSTEM DESCRIPTION AND THEORY OF OPERATION**

**DESCRIPTION**

The external cargo hook system consists of three separate cargo hooks mounted on the underside of the helicopter. The system allows a single load to be carried suspended at up to three points or three separate loads to be carried at the same time.

The center cargo hook is suspended from a beam under the cabin floor at sta. 331. The hook is attached to the beam with a bolt that lets the hook swing to each side. The beam is carried in bearings attached to structure at the sides of the rescue hatch in the floor. It can pivot forward and aft from the attaching points.

When not in use, the hook is stowed between cabin floor and rescue hatch door. In use, the hatch door is opened and the hook is unstrapped to hang down through the open hatch. The hook lifting capacity is **26,000 pounds**.

The forward and aft hooks hang from fittings attached to the floor beams at sta. 249 and 409. Each fitting is

a universal type that allows the hook to swing forward and aft and from side to side. Normally the hook is electrically actuated through a connector on the fuselage skin. It can also be released manually through a cable that connects to a release mechanism. The lifting capacity of each hook is **17,000 pounds**. When used together, the two hooks can lift a load of **25,000 pounds**.

All three hooks can be released in any one of three modes: normal, emergency, or manual. See Task 16-2 for a description of hook operation in each of these modes.

Power to operate the cargo hook system in normal operation comes from the No. 2 **28 vdc** bus. Two circuits are provided, each controlled by a separate circuit breaker. One circuit provides power to the system. The other contains the control switches and relays. Two separate power and control circuits are provided for emergency release of the hooks. Again, each has its own circuit breaker.

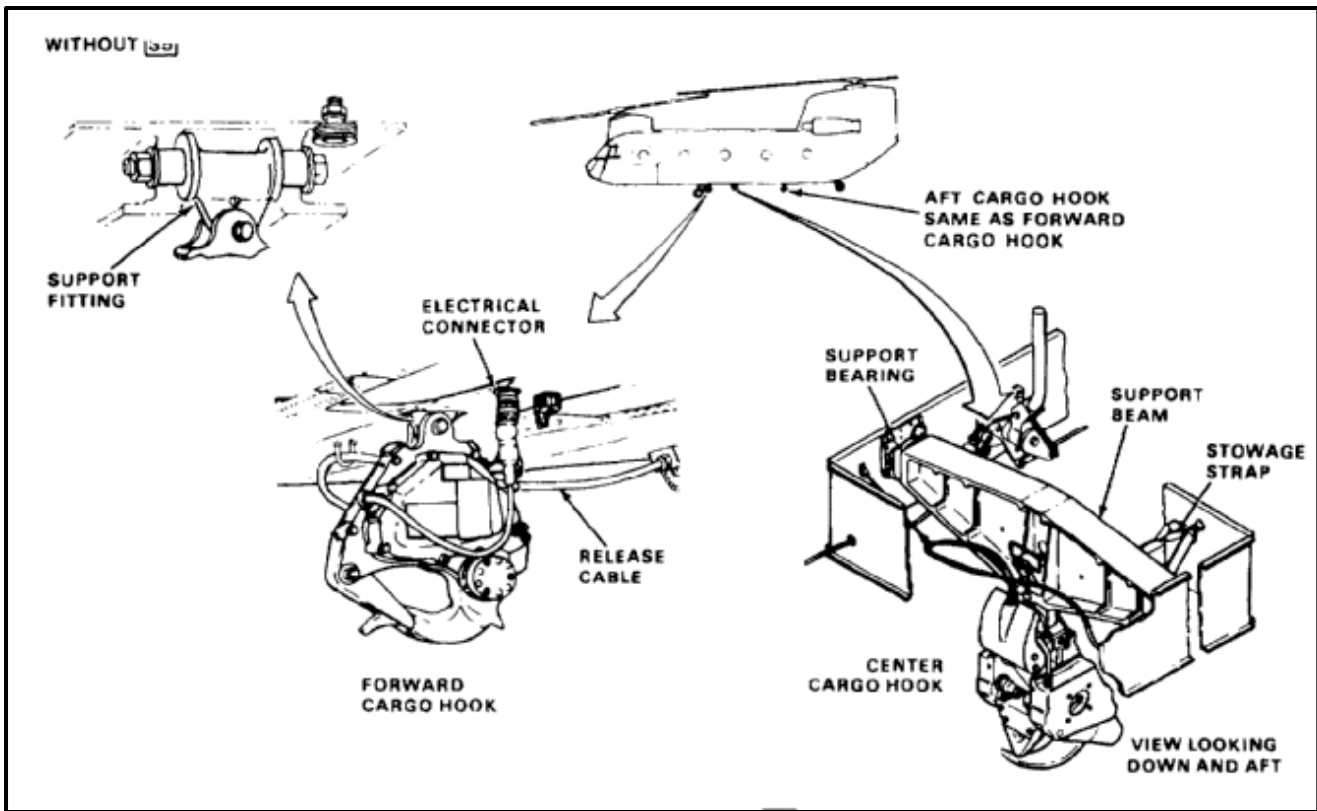

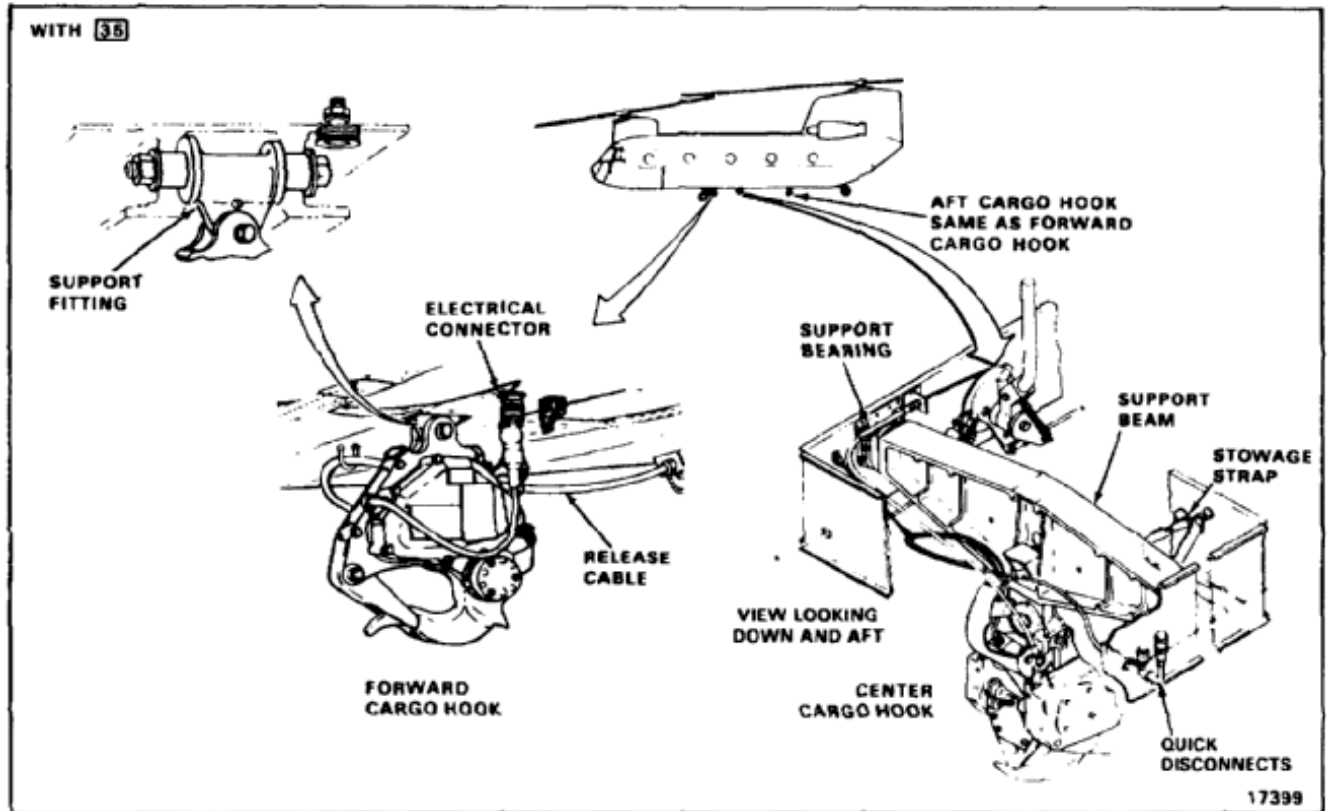

**CENTER CARGO HOOK LOADING POLE**

The cargo hook loading pole is used to pick up the sling loop of external cargo loads from inside the helicopter. The loop is then placed on the cargo hook by hand. The pole has a hook at one end and a cable at the other end. The cable is attached to the fuselage to prevent accidental loss of the pole when in use and to provide a discharge path for static electricity.

When not in use the pole is stowed on the lower right side of the cabin at about sta 360, just below the heater duct.

**WARNING**

Make sure the ground cable is connected when using the loading pole. With the rotors turning, static potential between the helicopter and a load on the ground can be as high as **40,000 volts**.

**THEORY OF OPERATION**

**Normal Release**

**NOTE**

The relays referred to in this section are in the Normal Release Relay Box at the right side of the cabin near sta. 280.

Setting the MASTER switch on the CARGO HOOK control panel to ARM energizes power control relay K1 through the control circuit breaker. The energized relay lights the ARMED SW FAIL light on the cabin relay box and arms the following:

System power circuit, through the power circuit breaker

CARGO REL buttons on the pilot's and copilot's control stick grips

CARGO HOOK switch on the HOIST OPERATOR PANEL in the cabin

Ground relay K4 contacts

Center hook release relay K3 contacts

Forward hook release relay K8 contacts

Aft hook release relay K9 contacts

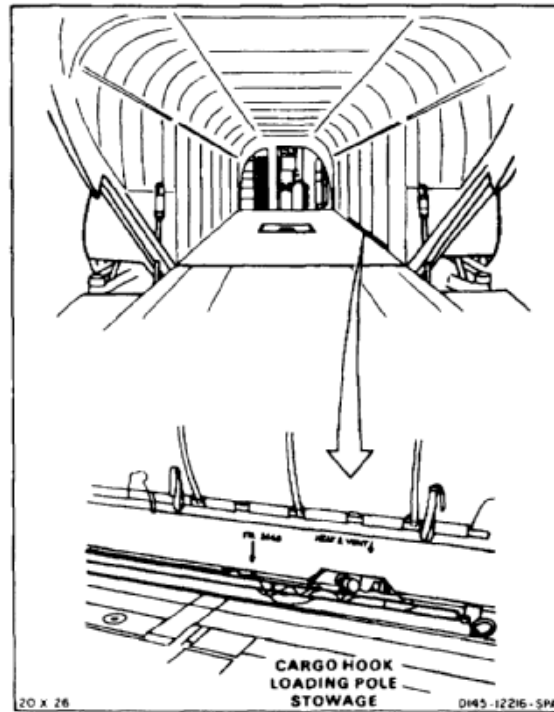

Setting the CARGO HOOK switch on the HOIST OPERATOR PANEL to ARM arms the CARGO HOOK RELEASE switch on the control grip in the cabin.

Operating the hook release button on either of the control stick grips or the hook release switch in the cabin energizes ground relay K4, which is then latched energized through its own contacts. The RELEASE SW FAIL and GROUND RELAY ACTIVATE lights on the relay box come on. The FAIL light stays lit as long as the release switch (or button) is held. The ACTIVATE light will stay lit as long as relay K4 stays energized.

The closed contacts of relay K4 also provide a ground for the center hook hydraulic solenoid valve and for the normal release relay circuits of the forward and aft hook.

Finally, the release switch (or button) energizes one or more of release relays K3 (center), K8 (forward), and K9 (aft), depending on the position of the HOOK SELECT switch on the cockpit overhead panel. Current from the power circuit flows through the closed release relay contacts to energize the release solenoid of the selected hook.

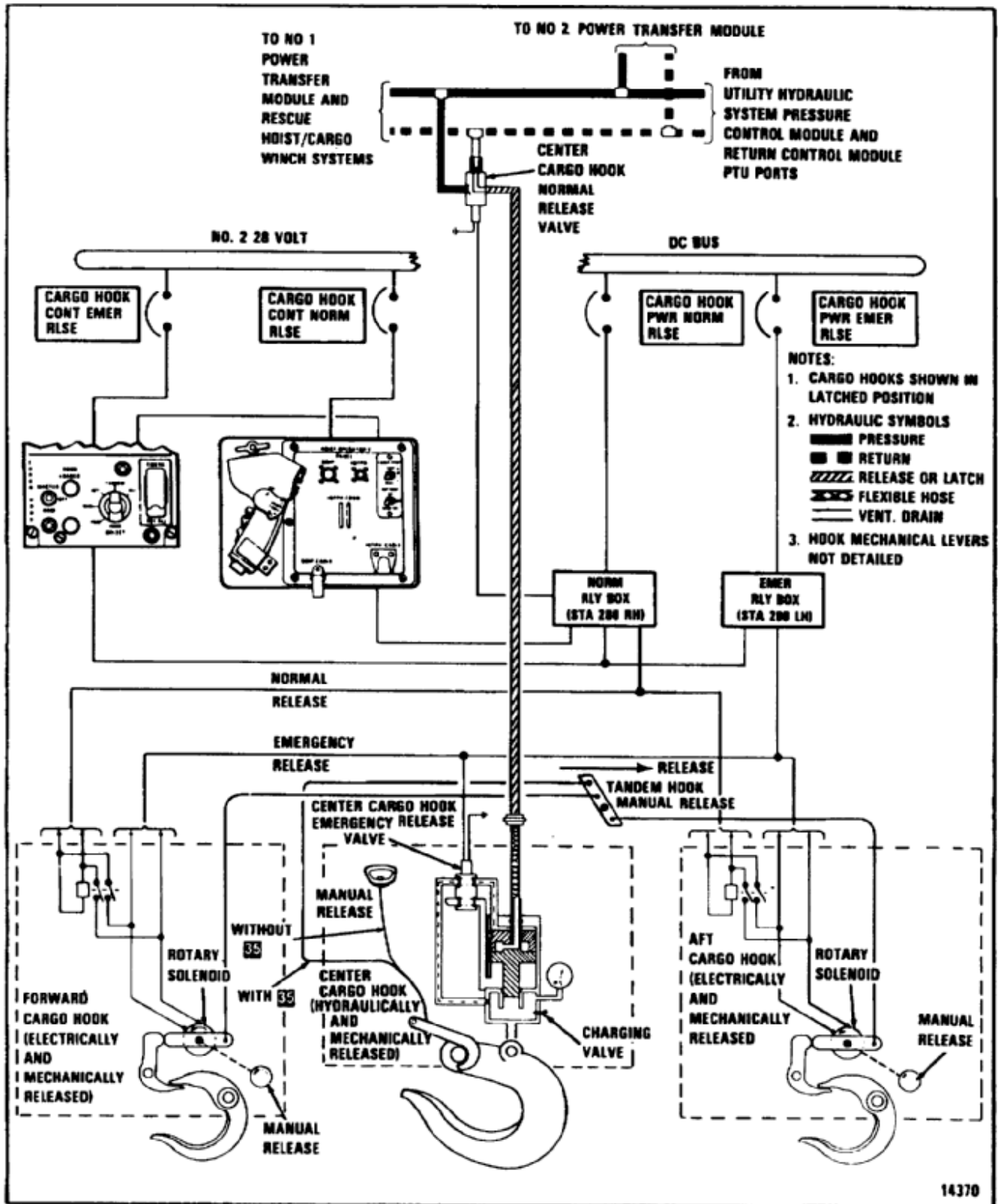

If the center cargo hook has been selected, the following sequence takes place:

With hydraulic solenoid valve 134L1 energized to open, pressurized fluid from the utility hydraulic system flows to the hook actuating cylinder. The cylinder is forced upward and the hook opens.

As the hook opens, it closes normally-open switch S3. At the same time, the moving cylinder closes normally-open switch S2. These switches complete the circuit to light the MID HOOK OPEN light on the master caution panel.

The hook will remain open until the MASTER switch on the cockpit overhead panel or the CARGO HOOK switch on the cabin panel is momentarily set to RESET. When this is done, latched relays K3 and K4 are deenergized, closing the hydraulic solenoid valve. The flow of hydraulic fluid to the cylinder is stopped and the fluid return line is opened, allowing pneumatic pressure stored in the cylinder to close the hook.

If the forward or aft cargo hook has been selected, the following sequence takes place:

When the release solenoid is energized, it moves the hook's release arm up, unlatching the release lever that holds the load beam closed. Assuming that the load is heavy enough to overcome the spring-loading of the beam, the beam pivots open, releasing the load. With the load released, the spring-loading closes the hook.

Almost immediately after the release solenoid is energized, a solenoid protection switch on the hook opens to reenergize the normal release relay. This deenergizes the solenoid, causing the protection switch to open again. The release solenoid is re-energized and the entire sequence repeats, continuing until the hook release button or switch is released.

When a hook is open, hook-open and linkage-open limit switches on the hook close. This energizes relay K5 (aft) or K6 (forward) to close. Contacts on these relays close to light the FWD or AFT HOOK OPEN lights on the master caution panel. When the cockpit MASTER switch or the cabin CARGO HOOK switch is set to RESET, the relays are deenergized and the lights go out.

A hook-loaded switch on each hook closes when a load of about **150 pounds** is applied. The closed switch completes a circuit to light the forward or aft HOOK LOADED light in the cockpit.

## EMERGENCY RELEASE

### NOTE

The relays referred to in this section are in the Emergency Hook Release Relay Box at left side of the cabin near sta. 280.

In the emergency release mode, all three hooks are opened at the same time by operating the EMER REL ALL guarded switch on the cockpit overhead panel. The sequence of operation is as follows:

When the emergency switch is operated, current from the flight essential bus flows through the CARGO HOOK CONT EMER RLSE circuit breaker and the switch to engage relay K1 and time delay relay K2.

Closed contacts in energized relay K1 allow current to flow through the CARGO HOOK CONT EMER RLSE circuit breaker to close contacts in the time delay relay. This activates the relay, holding the contacts closed for **10 seconds** after the cockpit switch is released. These closed contacts hold the contacts in relay K1 closed for the same **10-second** period. The closed K1 contacts keep a release solenoid on each of the three hooks energized.

The energized release solenoid on the center hook allows pneumatic pressure from a chamber in the hook actuating cylinder to flow to an auxiliary piston in the cylinder. Motion of this piston raises the cylinder to open the hook. When the solenoid is deenergized (after **10 seconds**), the directed pressure is vented to atmosphere. The remaining pressure in the pressurized chamber moves the cylinder to close the hook.

The release solenoids at the forward and aft hooks unlatch the hooks, allowing the load to pull them open. With the load released, the spring-loaded hooks close, latching when the release solenoids are deenergized (**10 seconds** after being deenergized).

**Manual Release Without 35**

Manual release of the center cargo hook is done by pulling a D-shaped ring at the top front of the hook. Pulling the D-ring releases a cam lock mechanism, allowing the hook to pivot open. Switch S2 closes to light the MID HOOK OPEN capsule on the master caution panel. The hook is reset manually by pushing up on the tip to lock the cams into position. When the hook is reset, switch S2 opens and the HOOK OPEN light goes out.

Manual release of the forward and aft hooks is done by the handle in the rescue hatch. Pulling the handle aft rotates a lever arm in each hook. This frees a latch to pivot away from the load beam (hook). The weight of the load is then free to pull the load beam open and the load drops. At the same time, an actuator in the hook linkage lights the FWD and AFT HOOK OPEN lights on the master caution panel. The hooks then return to the closed and latched position and the lights go out.

**Manual Release With 35**

Manual release of the center, forward, and aft cargo hooks is accomplished by using the handle in the rescue hatch.

Pulling the handle aft releases a cam lock mechanism, allowing the center hook to pivot open. Switch S2 closes to light the MID HOOK OPEN capsule on the master caution panel. The hook is reset manually by pushing up on the tip to lock the cams into position. When the hook is reset, switch S2 opens and the HOOK OPEN light goes out.

Pulling the handle aft also rotates a lever in the forward and aft hooks. This frees a latch to pivot away from the load beam (hook). The weight of the load is then free to pull the load beam open and the load drops. At the same time, an actuator in the hook linkage lights the FWD and AFT HOOK OPEN lights on the master caution panel. The hooks then return to the closed and latched position and the lights go out.

END OF TASK





**SECTION II**  
**CARGO CARRYING HOOK SYSTEM**

**NORMAL RELEASE**

The hook release system is normally operated from either cockpit or cabin. Selection of the hook or hooks to be released is made at a five position rotary HOOK SELECT switch on the overhead panel in the cockpit. Switch positions are FWD, MID, AFT, TANDEM, and ALL. The position of this switch determines which hook opens when the CARGO HOOK RELEASE switch on either control stick or the hoist operators grip is pressed. The switch operates through a dual hook relay box containing relays and three maintenance indicator lights.

Actual release of the hook or hooks is done from the cockpit or cabin. Cockpit release is made by the CARGO HOOK MASTER switch on the CARGO HOOK panel. The switch has three positions ARM, RESET and OFF. When the switch is set to ARM, power is applied to the CARGO HOOK RELEASE switches on the cyclic sticks and also to the CARGO HOOK ARMING switch at the hoist operators station. OFF position is used to close the mid cargo hook. RESET position is used to turn off the HOOK OPEN caution lights. Cabin operation is by a switch on the hoist operators grip.

The forward and aft hooks are electrically released. The center hook is hydraulically released through a solenoid valve in the tunnel area.

Three indicator lights on the master caution panel show if any of the three hooks are open. A fourth light indicates a fault in dual hook operation. It comes on to show if one of the hooks is not prepared to open.

**EMERGENCY RELEASE**

In an emergency, all three hooks can be released at the same time from a switch on the overhead panel in the cockpit. It is a guarded switch marked EMERG REL ALL. The switch releases all three hooks regardless of the position of the HOOK SELECT switch. Setting the switch to REL ALL, energizes an emergency hook release relay. The relay then energizes electrical release solenoids in the forward and aft hooks and a solenoid valve in the center hook. The solenoid valve in the center hook releases an aircharge stored in the lower half of the hydraulic actuator, transferring the charge to the upper release half of the actuator to open the hook.

After emergency release, the forward and aft hook will relatch automatically. The center hook must be manually reset and recharged with air to 2,000 to 2,200 psi.

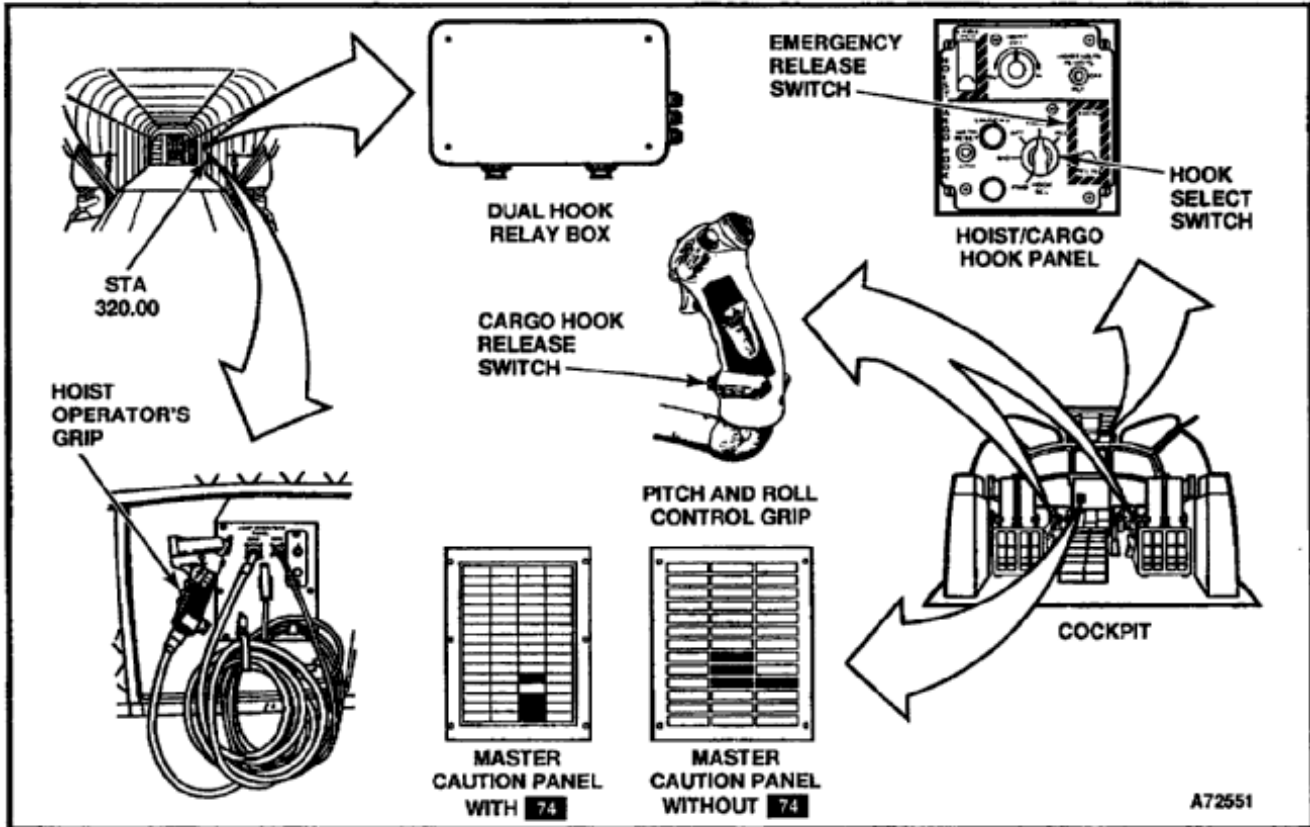

**MANUAL RELEASE WITHOUT 35**

If needed, all three hooks can be released by manual controls in the cabin rescue hatch area. The center hook has a manual release handle (D-ring). Pulling the ring unlocks the hook and lets it drop open. The forward and aft hooks are released at the same time by pulling a lever at the right side of the hatch. The center hook must be closed by hand after manual release. The

forward and aft hooks automatically reset closed after release. Manual release of all hooks is independent of the electrical, hydraulic, and pneumatic release systems.

**MANUAL RELEASE WITH 35**

All three hooks can be released at the same time by pulling a lever located at the right side of the hatch.

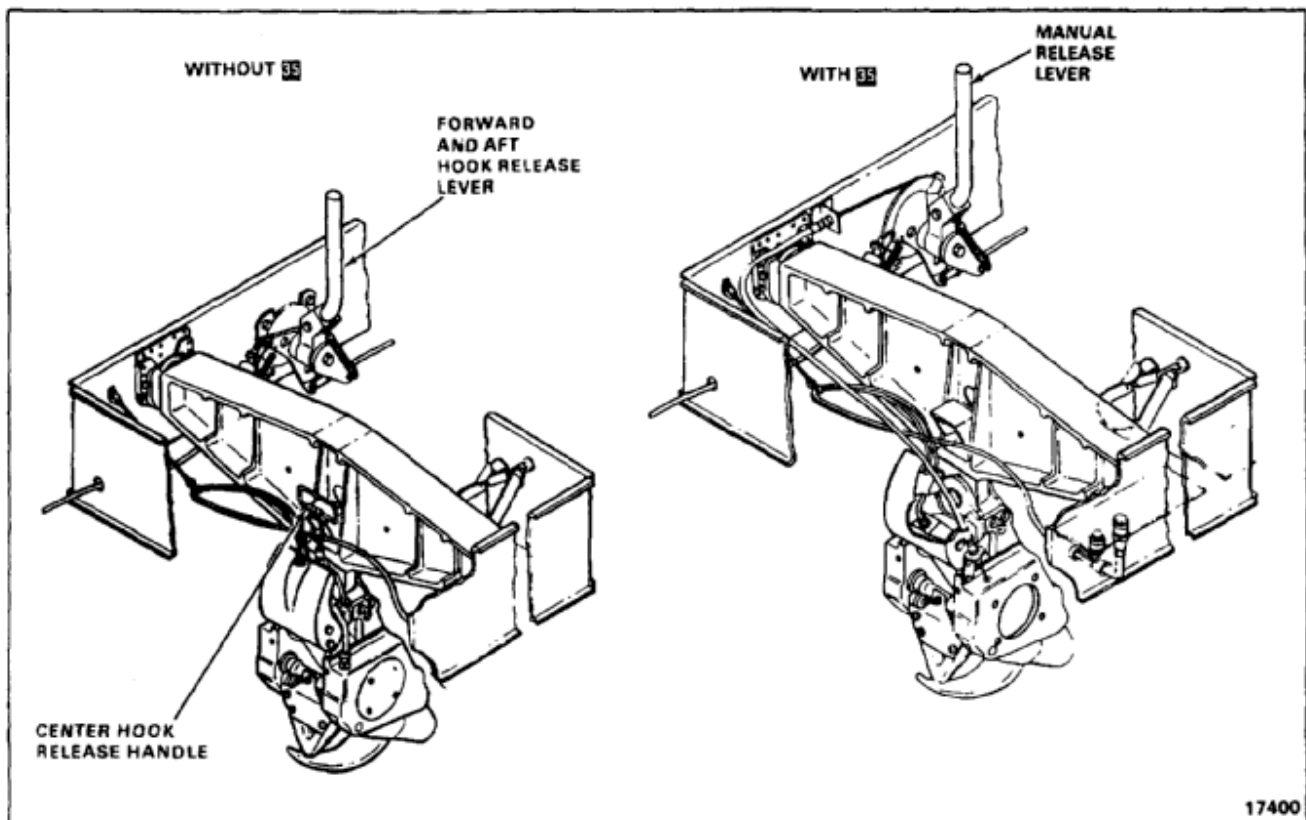

17400

END OF TASK

## INITIAL SETUP

**Applicable Configurations:**Without **35****Tools:**

Aircraft Mechanic's Tool Kit, NSN 5180-00-323-4692

**Materials:**

None

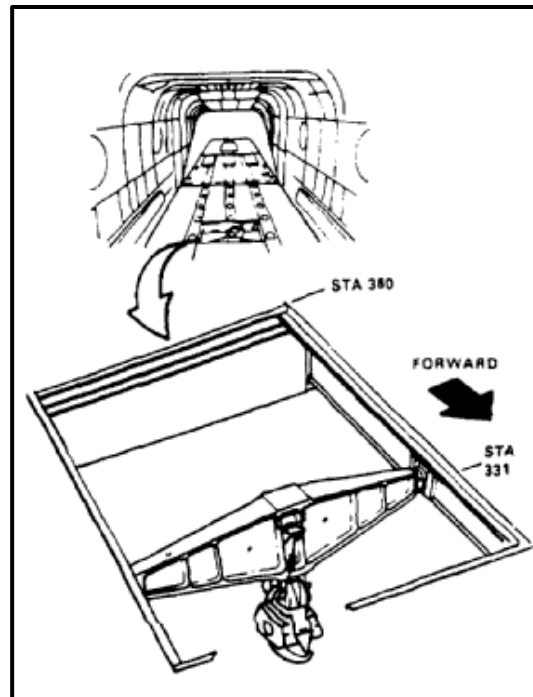
**Personnel Required:**Medium Helicopter Repairer  
Inspector**References:**Task 16-4  
Task 16-5  
Task 16-6  
Task 16-7  
Task 16-8**Equipment Condition:**Battery Disconnected (Task 1-39)  
Electrical Power Off  
Hydraulic Power Off  
Rescue Hatch Lower Door at Lowest Position (Task 2-193)  
Rescue Hatch Access Door Opened (Task 2-2)

Following a manual release under load and before rematching, center hook must be inspected. Otherwise, damage which could affect operation of manual release mechanism may be overlooked.

1. After each manual release, visually check block (1), bolt (2), sleeve spacer (3) and keeper (4) and beam (5) for damage, binding, or distortion. There shall be no damage, binding, or distortion.

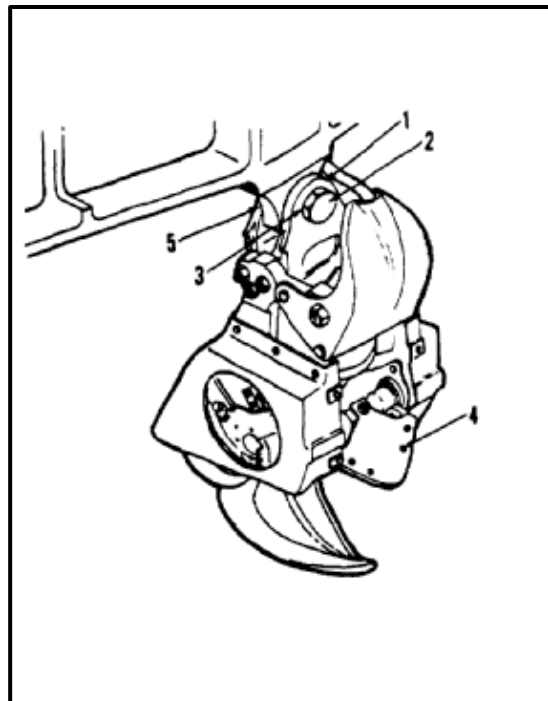

**16-3 INSPECTION AND RELATCHING OF CENTER HOOK MANUAL RELEASE MECHANISM (Continued)**

16-3

2. After each manual release, check spring return operation of keeper (4) as follows:
  - a. Push keeper (4) in toward back of hook (5.1).
  - b. Release keeper (4). Keeper shall return to original position.

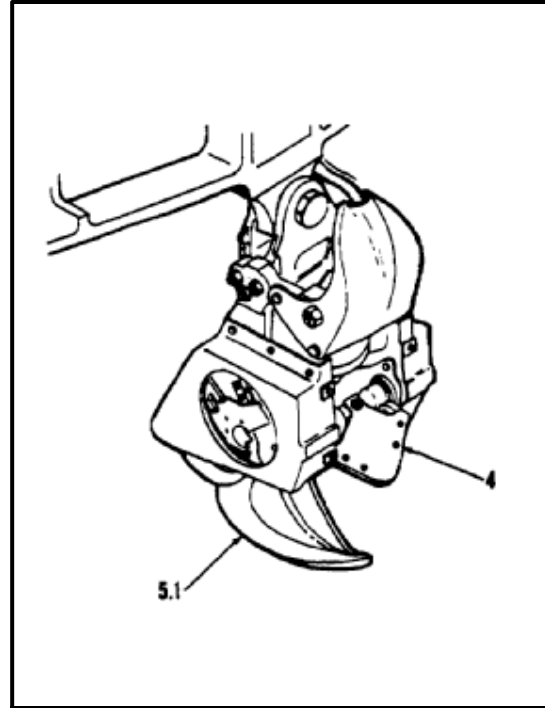

3. Relatch manual release mechanism as follows:
  - a. Deleted.
  - b. Holding rear of hook, position hook pivot pins (9) into cutouts of rotating cams (10) and formers (11).

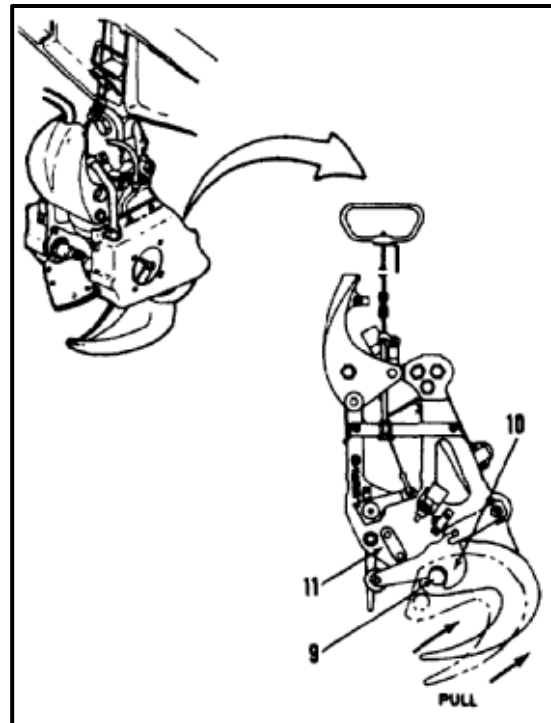

- c. Pull rear of hook aft. Rotate tip of hook upwards until rotating cams (10) contact release lever (12).

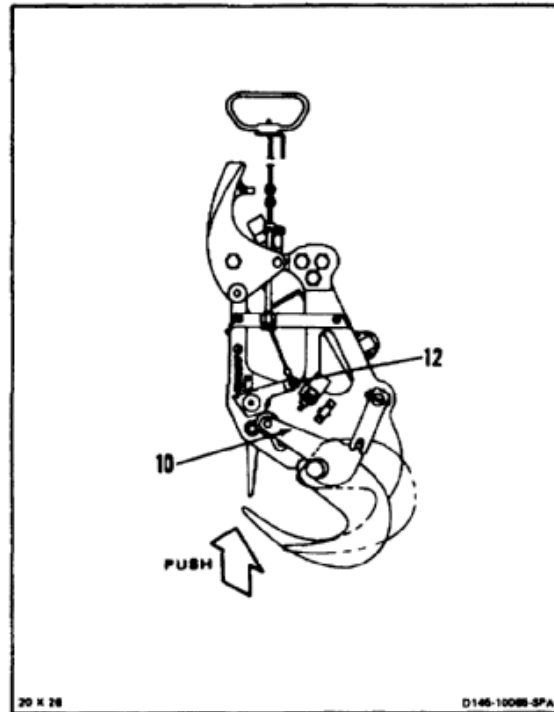

**WARNING**

Ensure cam roller is fully seated in locked position and hook is fully seated in cam lock, or hook will release under loaded conditions.

- d. Pull manual release handle (13) and push tip of hook upward until rotating cams (10) are behind release lever (12).
- e. Release manual release handle (13).
- f. Ensure rotating cams (10) are against cam stop (14). Ensure release lever (12) is fully clockwise as shown.

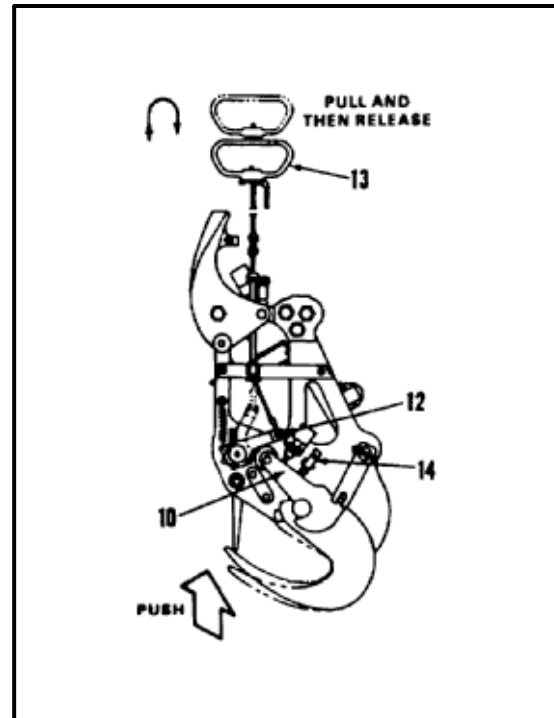

**16-3 INSPECTION AND RELATCHING OF CENTER HOOK MANUAL RELEASE MECHANISM (Continued)**

16-3

- g. Secure manual release handle (13) in angle plate (15) and cradle (16).
- h. Move hook (5.1) to the left until it stops against beam (17) and then to the right until it stops against beam (17). There shall be no tension on cable (14.1) when hook is moved. Ensure release lever (12) did not move.

**INSPECT****NOTE**

If performing a third manual release under load, continue with step 4. If not performing third release, go to Follow-On Maintenance.

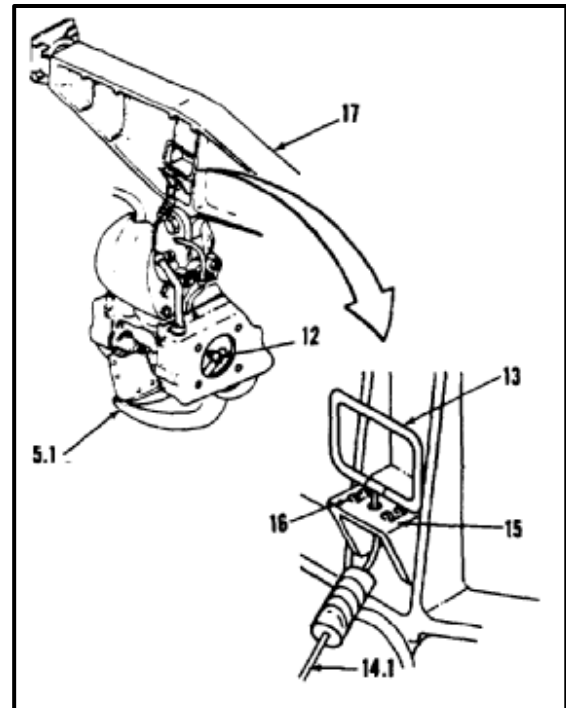
**SPECIAL INSPECTION**

4. After every third manual release under load, perform a special inspection as follows:
  - a. Remove hook (5.1) (Task 16-4).
  - b. Disassemble hook (5.1) (Task 16-5).

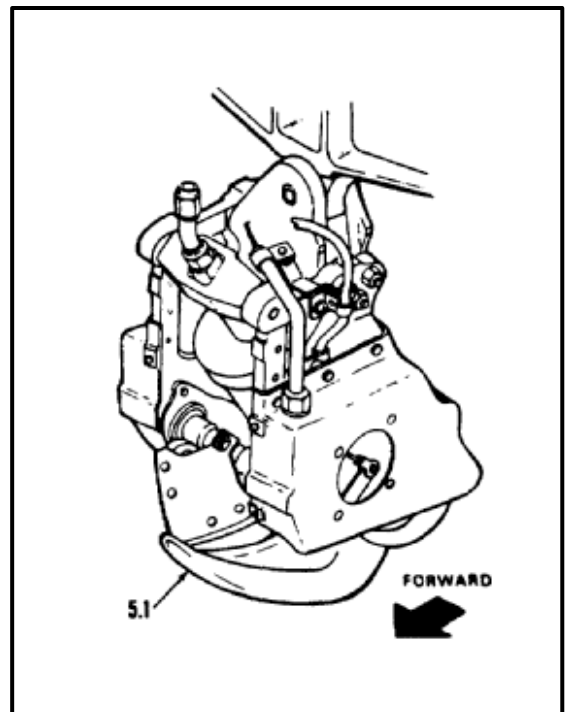

**16-3 INSPECTION AND RELATCHING OF CENTER HOOK MANUAL RELEASE MECHANISM (Continued)**

16-3

- c. Check bolt (2), block (1), sleeve spacer (3), and keeper (4) for damage. Replace as required.
- d. Inspect components of hook (5) (Task 16-6).

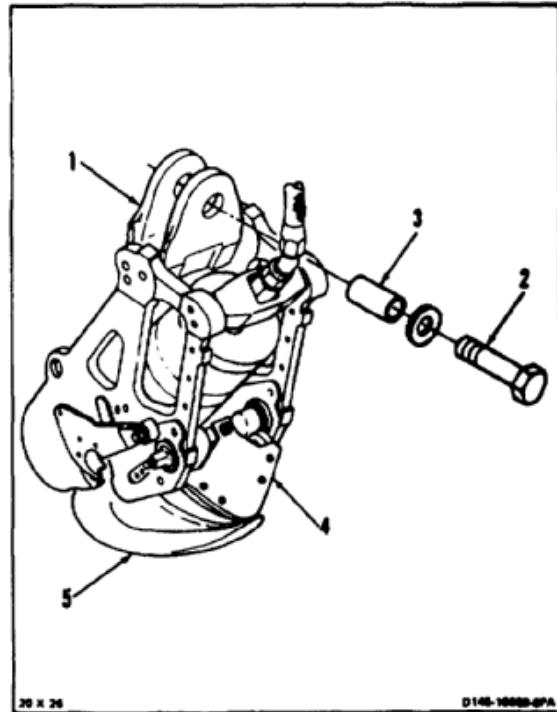

**NOTE**

During assembly procedure, manual release mechanism will automatically be assembled in related position.

- e. Assemble hook (5) (Task 16-7).
- f. Install hook (5) (Task 16-8).
- g. Pull down on hook. Hook must be related.

**FOLLOW-ON MAINTENANCE:**

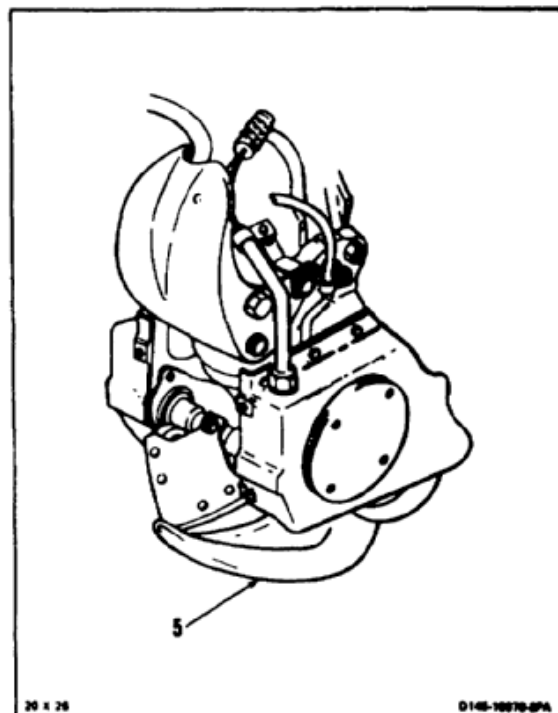
Perform operational check of hook (TM 55-1520-240-T).



END OF TASK



## INITIAL SETUP

**Applicable Configurations:**

With **35**

**Tools:**

Aircraft Mechanic's Tool Kit, NSN 51 80-00-323-4692

**Materials:**

None

**Personnel Required:**

Medium Helicopter Repairer  
Inspector

**References:**

Task 16-4.1  
Task 16-5.1  
Task 16-6  
Task 16-7.1  
Task 16-8.1

**Equipment Condition:**

Battery Disconnected (Task 1-39)  
Electrical Power Off  
Hydraulic Power Off  
Rescue Hatch Lower Door at Lowest Position (Task 2-193)  
Rescue Hatch Access Door Opened (Task 2-2)



Following a manual release under load and before rematching, center hook must be inspected. Otherwise, damage which could affect operation of manual release mechanism may be overlooked.

1. After each manual release, visually check block (1), bolt (2), sleeve spacer (3) and keeper (4) and beam (5) for damage, binding, or distortion. There shall be no damage, binding, or distortion.

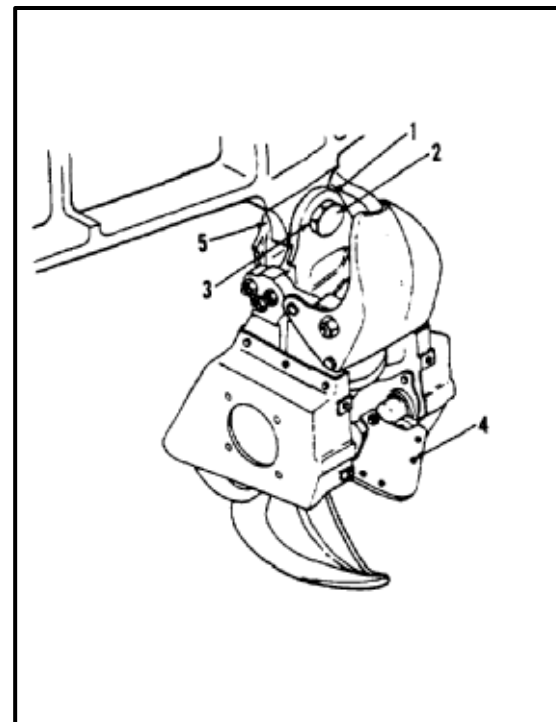
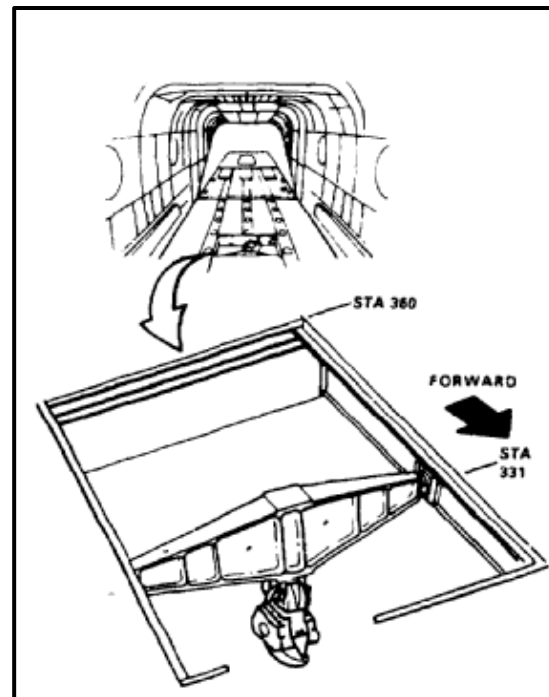

2. After each manual release, check spring return operation of keeper (4) as follows:
  - a. Push keeper (4) in toward back of hook (5.1).
  - b. Release keeper (4). Keeper shall return to original position.

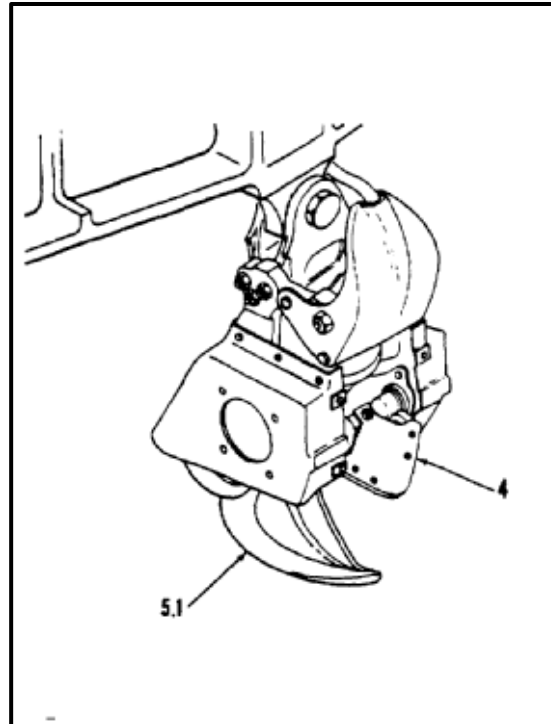

3. Relatch manual release mechanism as follows:
  - a. Deleted.
  - b. Holding rear of hook, position hook pivot pins (9) into cutouts of rotating cams (10) and formers (11).

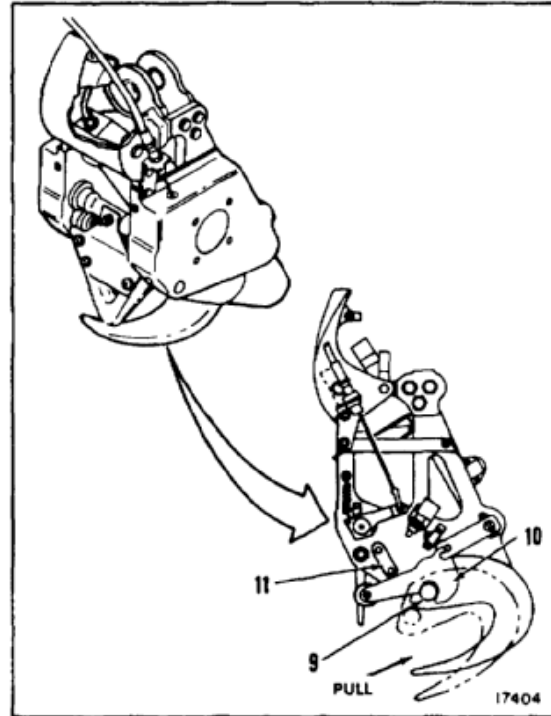

**16-3.1 INSPECTION AND RELATCHING OF CENTER HOOK MANUAL RELEASE MECHANISM (Continued)**

16-3.1

- c. Pull rear of hook aft. Rotate tip of hook upwards until rotating cams (10) contact release lever (12).

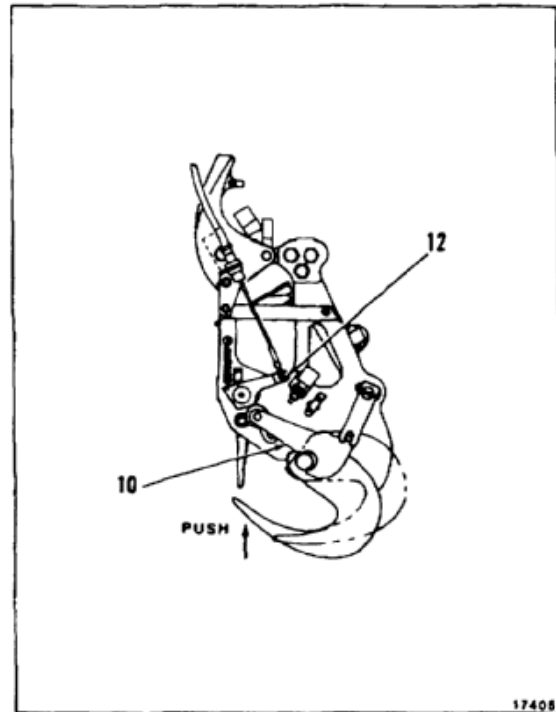
**WARNING**

Ensure cam roller is fully seated in locked position and hook is fully seated in cam lock, or hook will release under loaded conditions.

- d. Rotate manual release lever (13) aft and push tip of hook upward until rotating cams (10) are behind release lever (12).
- e. Release manual release lever (13).
- f. Ensure rotating cams (10) are against cam stop (14). Ensure release lever (12) is fully clockwise as shown.

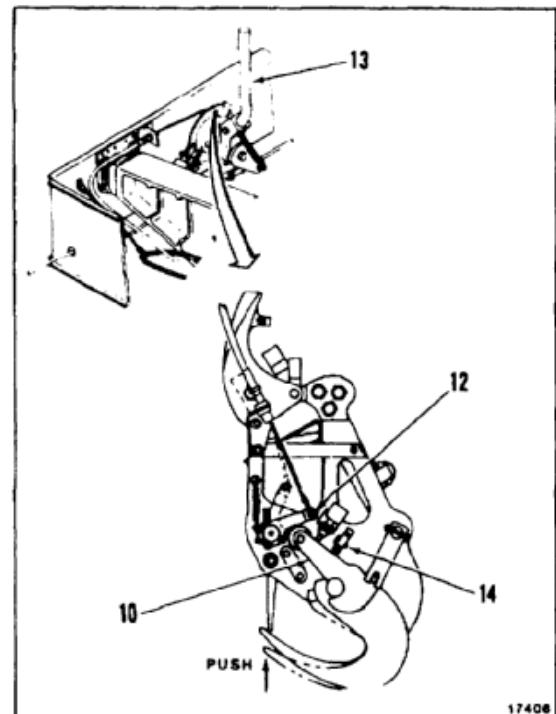

- g. Move hook (5.1) to the left until it stops against beam (15) and then to the right until it stops against beam (15). There shall be no tension on cable (16) when hook is moved. Ensure release lever (12) did not move.

**INSPECT**

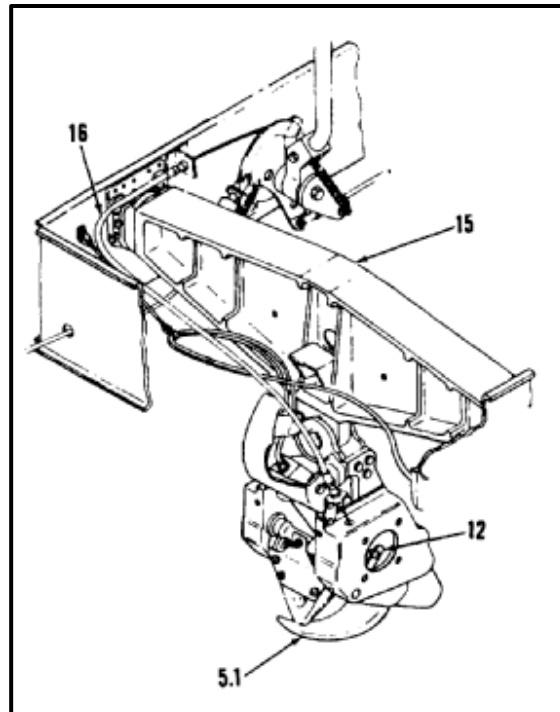

**NOTE**

If performing a third manual release under load, continue with step 4. If not performing third release, go to Follow-On Maintenance.

**SPECIAL INSPECTION**

- 4. After every third manual release under load, perform a special inspection as follows:
  - a. Remove hook (5.1) (Task 16-4.1).
  - b. Disassemble hook (5.1) (Task 16-5.1).

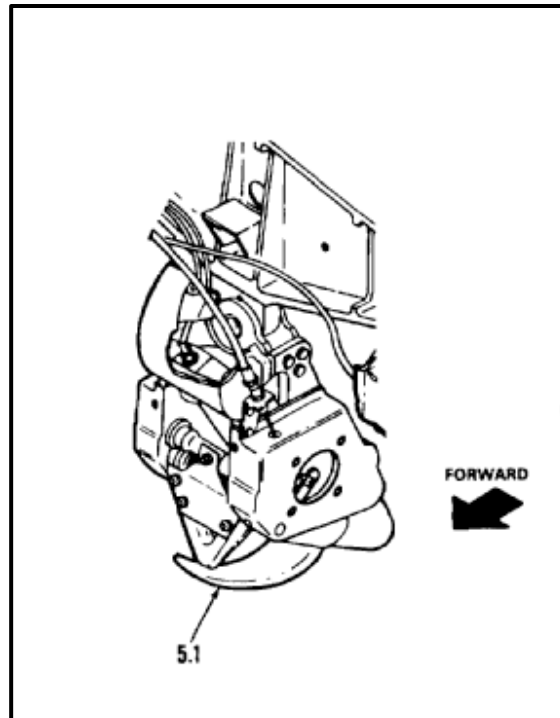

**16-3.1 INSPECTION AND RELATCHING OF CENTER HOOK MANUAL RELEASE MECHANISM (Continued)**

16-3.1

- c. Check bolt (2), block (1), sleeve spacer (3), and keeper (4) for damage. Replace as required.
- d. Inspect components of hook (5.1) (Task 16-6).

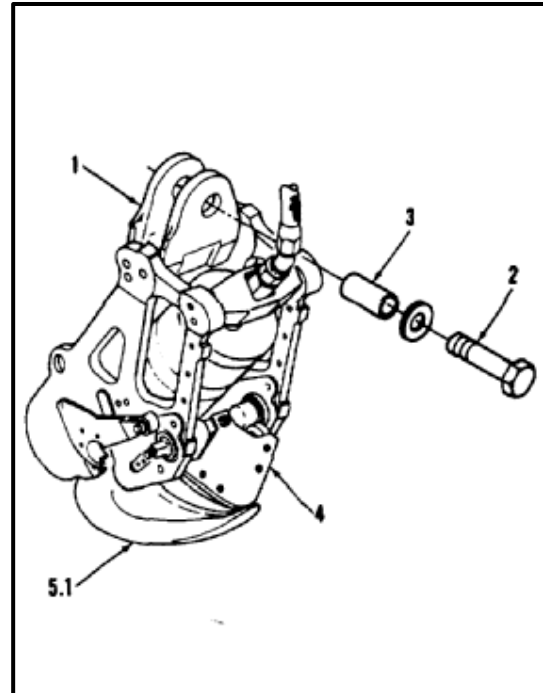

**NOTE**

During assembly procedure, manual release mechanism will automatically be assembled in related position.

- e. Assemble hook (5.1) (Task 16-7.1).
- f. Inspect the support fitting (17) on the beam (15) for cracks and distortion.
- g. Install hook (5.1) (Task 16-8.1).
- h. Pull down on hook. Hook must be related.

**FOLLOW-ON MAINTENANCE:**

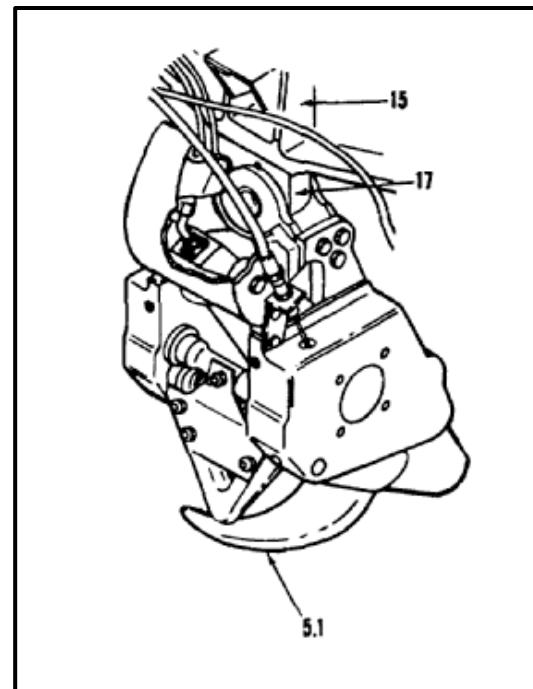
Perform operational check of hook (TM 55-1520-240-T).



END OF TASK

## INITIAL SETUP

**Applicable Configurations:**Without **35****Tools:**

None

**Materials:**

None

**Personnel Required:**

Medium Helicopter Repairer

**References:**

TM 55-1520-240-23P

**Equipment Condition:**

- Battery Disconnected (Task 1-39)
- Electrical Power Off
- Hydraulic Power Off
- Rescue Hatch Access Door Open (Task 2-2)
- Rescue Hatch Lower Door Open (Task 2-193)
- Cargo Hook Unstowed (Task 16-4)

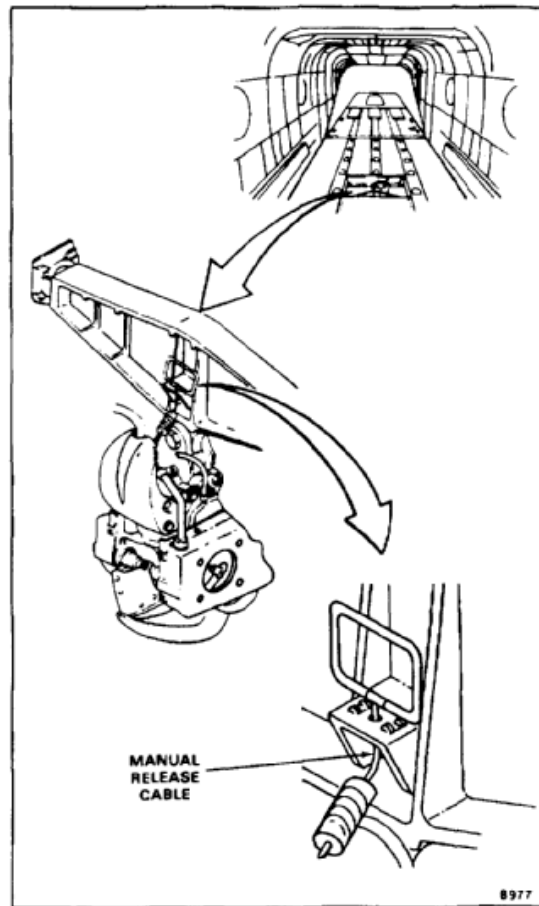
**REMOVE CABLE**

1. Compress cable lock (1) and pull out cable (2). Release cable lock.
2. Pull cable (2) through angle plate (3).

**INSTALL CABLE**

3. Thread cable (2) through angle plate (3).
4. Compress cable lock (1) and insert ball end of cable (2). Release cable lock.
5. Secure handle (4) in angle plate (3) and cradle (5).

**FOLLOW-ON MAINTENANCE:**

Perform operational check of hook (TM 55-1520-240-T).

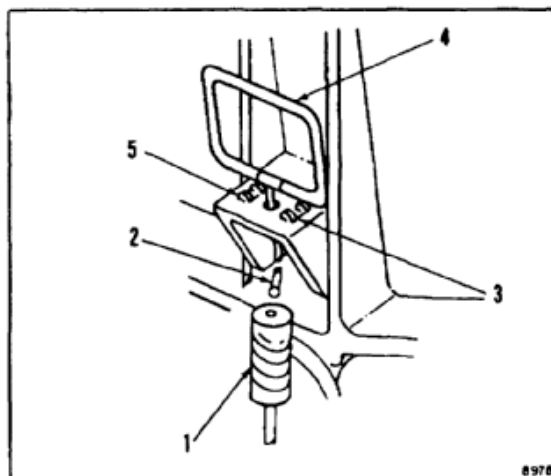

END OF TASK

**16-3.3 REMOVE CENTER HOOK MANUAL RELEASE CABLE**

16-3.3

**INITIAL SETUP****Applicable Configurations:**With **35****Tools:**

Aircraft Mechanic's Tool Kit, NSN 5180-00-323-4692

**Materials:**

None

**Personnel Required:**

Medium Helicopter Repairer

**References:**

TM 55-1520-240-23P

**Equipment Condition:**

Battery Disconnected (Task 1-39)  
 Electrical Power Off  
 Hydraulic Power Off  
 Rescue Hatch Access Door Open (Task 2-2)  
 Rescue Hatch Lower Door Open (Task 2-193)  
 Cargo Hook Unstowed (Task 16-4.1)

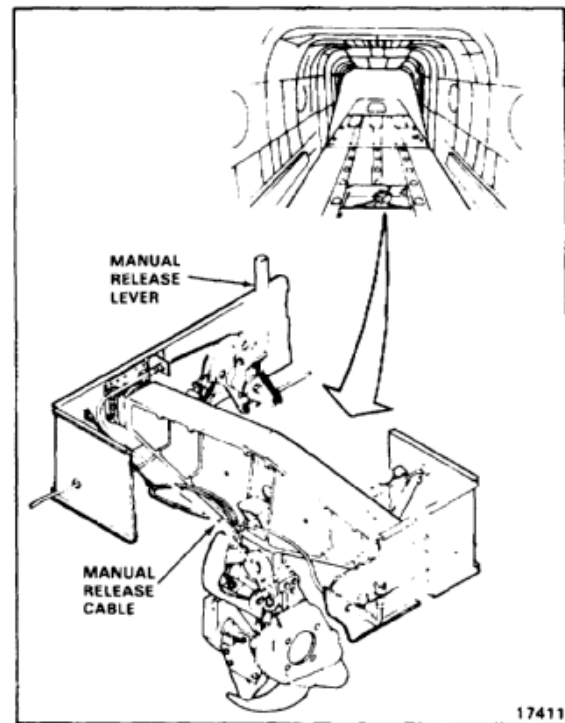

1. Remove lockwire from jam nuts (1 and 2).
2. Loosen jam nut (1).
3. Remove lockwire from bolt (3).
4. Remove bolt (3) and washer (4) from bellcrank (5).

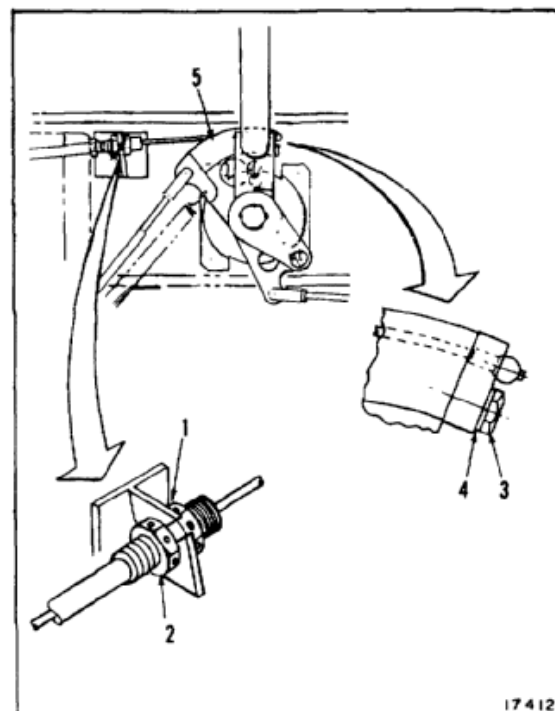

5. Remove lockwire from jam nuts (6 and 7).
6. Loosen jam nut (6).
7. Remove cotter pin (8), washer (9), and straight head pin (10) from lever (11).
8. Remove cable (12).

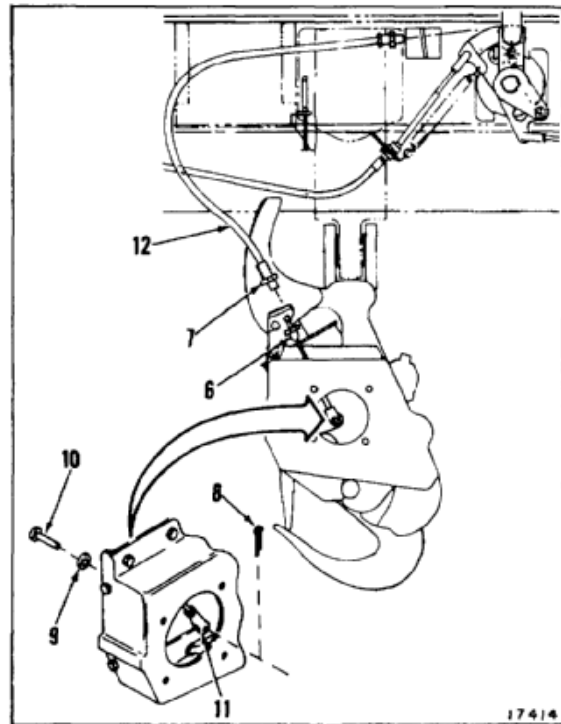
***FOLLOW-ON MAINTENANCE:***

None

END OF TASK



**16-3.4 INSTALL CENTER HOOK MANUAL RELEASE CABLE**

16-3.4

**INITIAL SETUP****Applicable Configurations:**With **35****Tools:**

Aircraft Mechanic's Tool Kit, NSN 5180-00-323-4692  
Torque Wrench, 1/4 Inch Drive, NSN  
5120-00-542-4489

**Materials:**

Lockwire (E231)

**Personnel Required:**

Medium Helicopter Repairer  
Inspector

**References:**

TM 55-1520-240-23P

**Equipment Condition:**

Battery Disconnected (Task 1-39)  
Electrical Power Off  
Hydraulic Power Off  
Rescue Hatch Lower Door at Lowest  
Rescue Hatch Access Door Open (Task 2-2)  
Rescue Hatch Lower Door Open (Task 2-193)  
Cargo Hook Unstowed (Task 16-4.1)

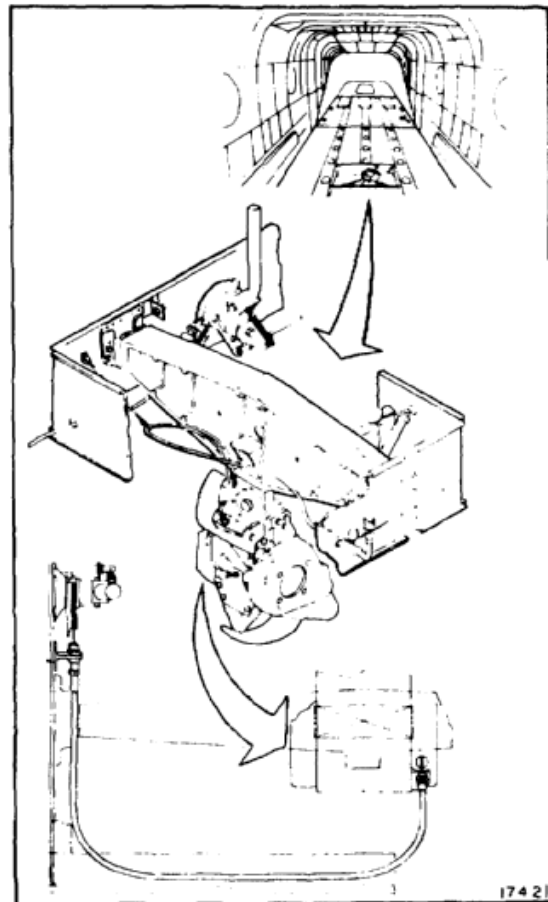

1. Route cable (1) through slot in bracket (2).
2. Align holes in clevis (3) and lever (4). Install straight head pin (5), washer (6), and cotter pin (7).
3. Check that cable (1) protrudes past bracket (2) **0.70 to 0.75 inch**. This dimension is for initial installation and may change during final adjustment.
4. Hold jam nut (8). Tighten jam nut (9). Lockwire nuts together. Use lockwire (E231).

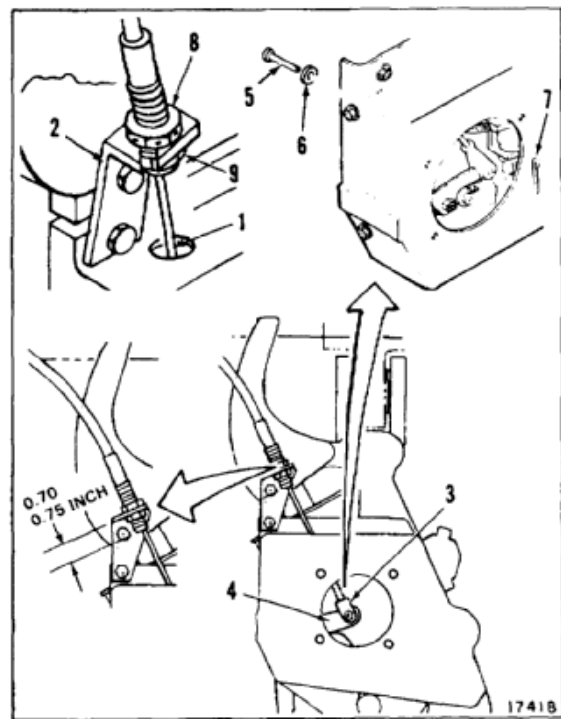

5. Route cable (1) through slot in bracket (10) and over bellcrank (11).

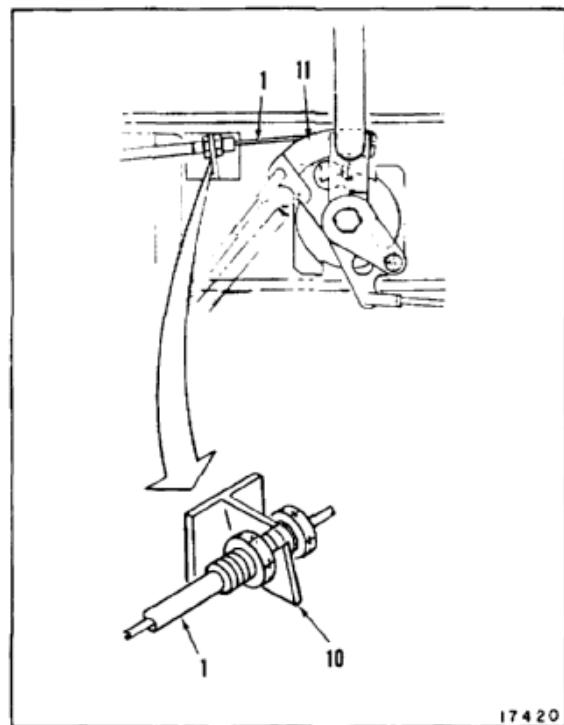

**16-3.4 INSTALL CENTER HOOK MANUAL RELEASE CABLE (Continued)**

16-3.4

6. Check that cable (1) protrudes past bracket (10) **0.70 to 0.75 inch**. This dimension is for initial installation and may change during final adjustment.
7. Hold jam nut (12). Tighten jam nut (13). Lockwire nuts together. Use lockwire (E231).
8. Install bolt (14) and washer (15) securing cable (1) to bellcrank (11). Torque bolt **20 to 35 inch-pounds**.
9. Lockwire bolt (14). Use lockwire (E231).

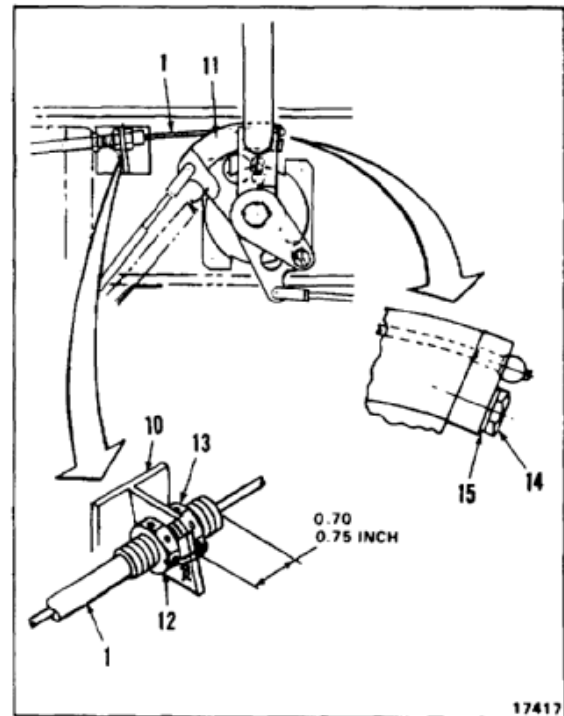
**INSPECT****FOLLOW-ON MAINTENANCE:**

Adjust cable (Task 16-3.5).

END OF TASK

## INITIAL SETUP

**Applicable Configurations:**

With **35**

**Tools:**

Aircraft Mechanic's Tool Kit, NSN 5180-00-323-4692  
Torque Wrench, 5 to 50 Inch-Pounds

**Materials:**

Lockwire (E231)

**Parts:**

None

**Personnel Required:**

Medium Helicopter Repairer  
Inspector

**References:**

TM 55-1520-240-23P  
TM 55-1520-240-T

**Equipment Condition:**

Battery Disconnected (Task 1-39)  
Electrical Power Off  
Hydraulic Power Off  
Forward and Aft Cargo  
Hook Manual Release Cable Adjusted (Task 16-35.1)  
Inspection And Relatching of Center Hook Manual  
Release Mechanism (Tasks 16-3 or 16-3.1)

**General Safety Instructions:****WARNING**

Improper adjustment of release cables  
can result in loss of life or serious  
injury to personnel.

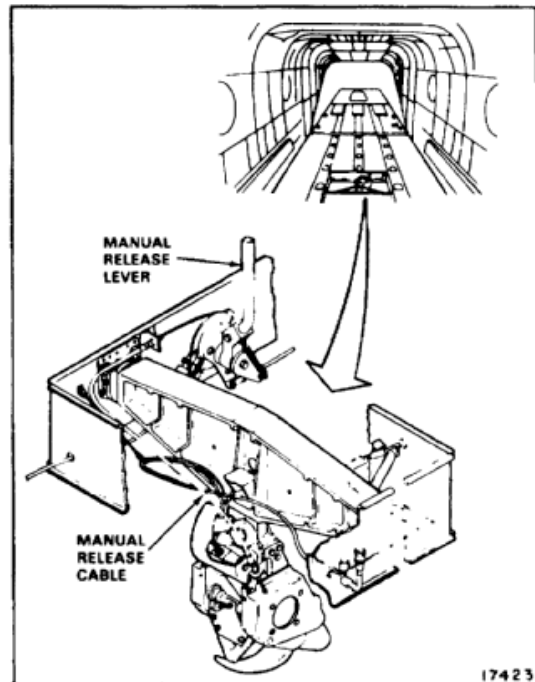

**16-3.5 ADJUST CENTER CARGO HOOK MANUAL RELEASE CABLE (Continued)****16-3.5**

1. Manually close forward, center, and aft cargo hooks (1, 2, and 3).

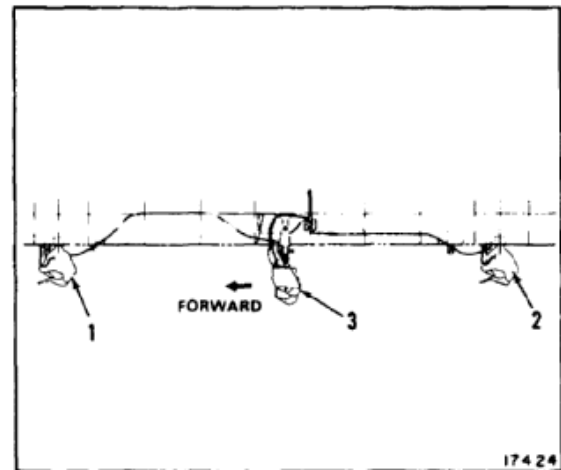

2. Set manual release handle (4) in vertical position.



The center hook must be relatched in accordance with Tasks 16-3 or 16-3.1 as applicable

3. Check clearance at bellcrank (5) and cable ball (6). Clearance shall be **0.0 to 0.10 inch**.
4. If clearance is within limits specified, go to step 8. If clearance is not within limits specified, go to step 5.

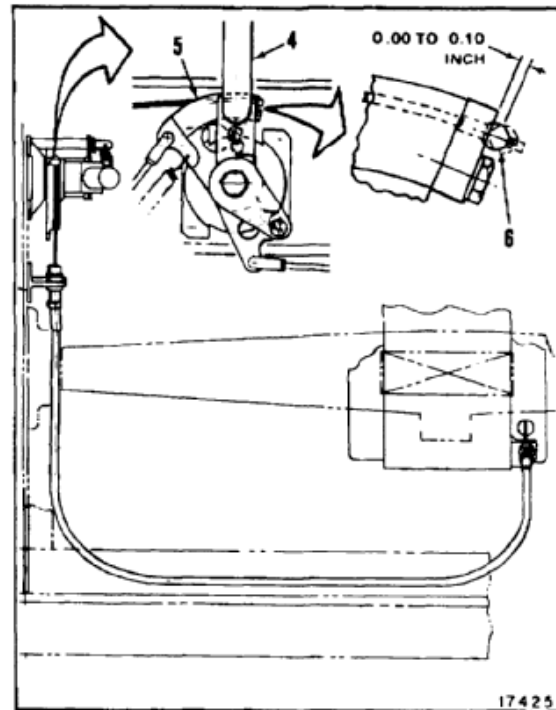

5. Remove lockwire from jam nuts (7 and 8) and (9 and 10) if installed.

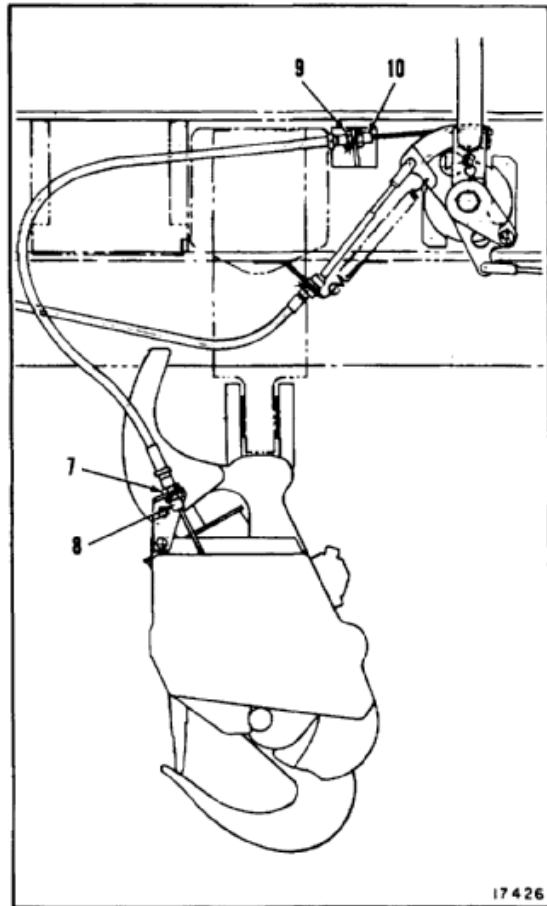

**16-3.5 ADJUST CENTER CARGO HOOK MANUAL RELEASE CABLE (Continued)**

16-3.5

6. Adjust cable (1) at both ends at bracket locations until clearance in step 3 is reached.
7. Tighten jam nuts (7 and 8) and (9 and 10). Use care not to move cable (1).
8. Perform operational check of cargo hook (TM 55-1520-240-T).
9. Lockwire jam nuts (7 and 8) together and (9 and 10) together. Use lockwire (E231).

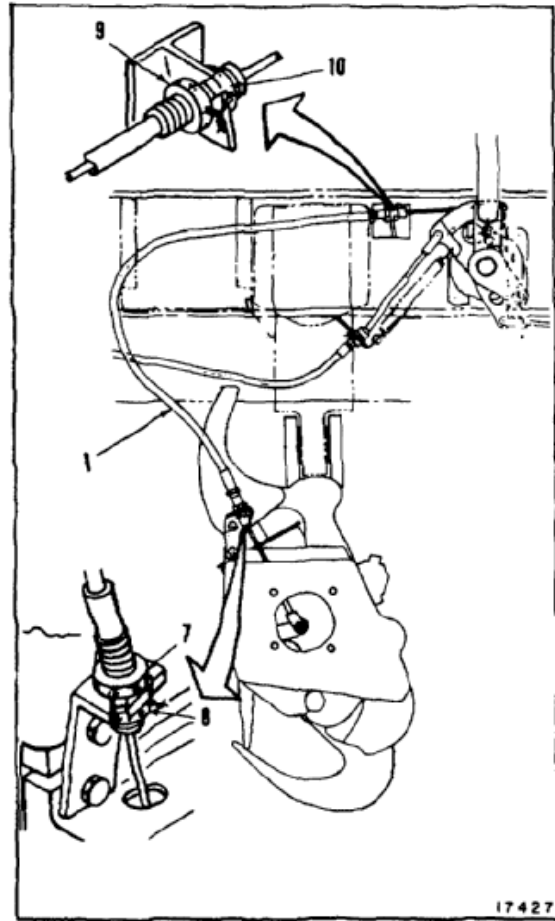
**INSPECT****FOLLOW-ON MAINTENANCE:**

Close rescue hatch (Task 2-2).

END OF TASK

## INITIAL SETUP

**Applicable Configurations:**Without **35****Tools:**

Aircraft Mechanic's Tool Kit, NSN 5180-00-323-4692  
 Open End Wrench (2), 1-1/16 Inch  
 Socket, 1-1/16 Inch

**Materials:**

None

**Personnel Required:**

Medium Helicopter Repairer (2)

**Equipment Condition:**

Battery Disconnected (Task 1-39)  
 Electrical Power Off  
 Hydraulic Power Off  
 Rescue Hatch Open (Task 2-2)

**General Safety Precautions:****WARNING**

Before removing cargo hook, release nitrogen precharge or personnel injury could occur.

1. Have helper support hook (1). Release stowage strap (2).
2. Lower hook (1) until it hangs free.
3. Disconnect hose (3) at quick-disconnect (4).
4. Disconnect electrical cable (5) at connector (6).
5. Remove nut (7), washer (8), and screw (9) from clamp (10).

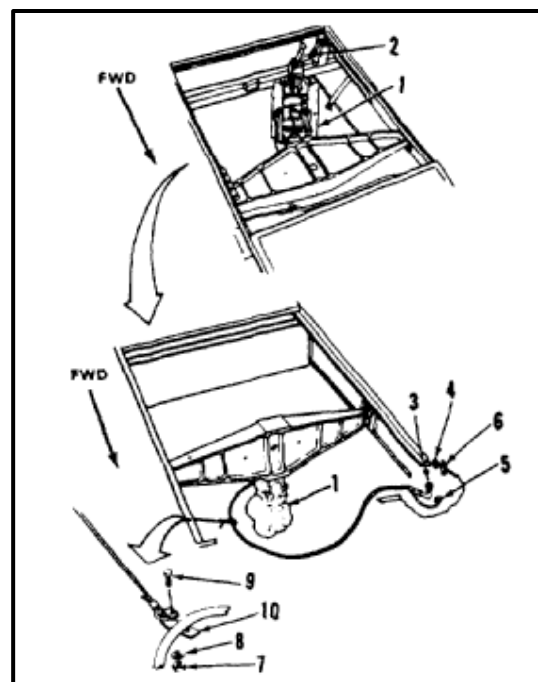
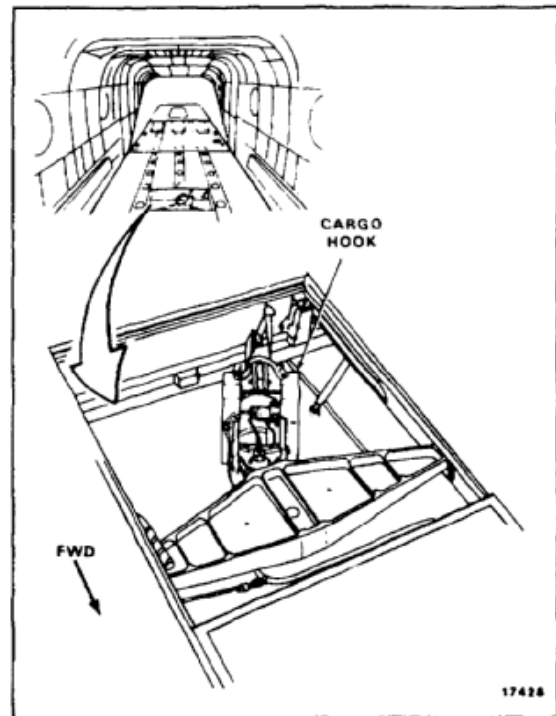



**16-4 REMOVE CENTER CARGO HOOK (Continued)**

16-4

6. Remove clamp (10) and bungee cord (11) from hose (3) and electrical cable (5).
7. Disconnect manual release cable (12) at cable lock (13).

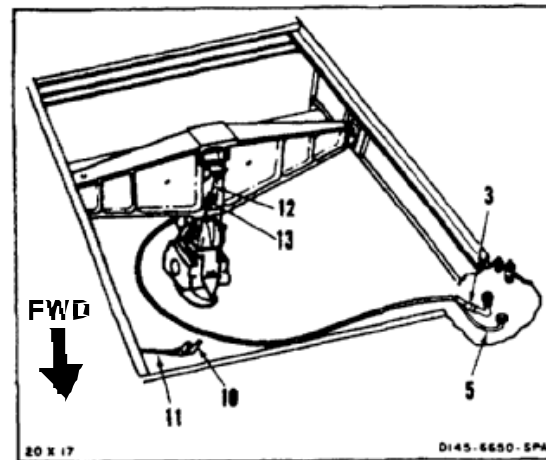

8. Remove two bolts (14) and six washers (15) from guard (16).
9. Remove two bolts (17), washers (18), and clamps (19) from guard (16).
10. Spread guard (16) to clear bolt (20) and nut (21). Remove guard.

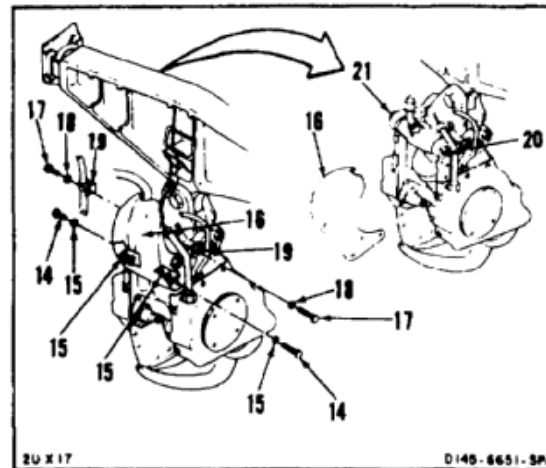

11. Remove cotter pin (22), nut (23), two washers (24), and bolt (25) from cargo hook (1).
12. Have helper support hook (1). Remove sleeve spacer (26).
13. Remove cargo hook (1).

**FOLLOW-ON MAINTENANCE:**

None

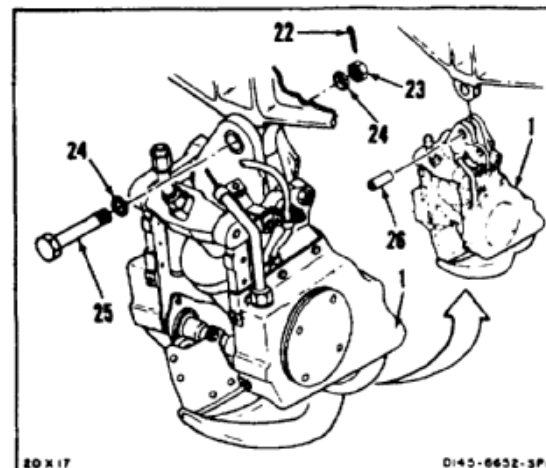

END OF TASK

## INITIAL SETUP

**Applicable Configurations:**With **35****Tools:**

Aircraft Mechanic's Tool Kit, NSN 5180-00-323-4692  
 Open End Wrench (2), 1-1/16 Inches (2)  
 Socket, 1/16 Inch

**Materials:**

None

**Personnel Required:**

Medium Helicopter Repairer (2)

**Equipment Condition:**

Battery Disconnected (Task 1-39)  
 Electrical Power Off  
 Hydraulic Power Off  
 Rescue Hatch Open (Task 2-2)

**General Safety Precautions:****WARNING**

Before removing cargo hook, release nitrogen precharge or personnel injury could occur.

1. Have helper support hook (1). Release stowage strap (2).
2. Lower hook (1) until it hangs free.
3. Disconnect hose (3) at quick-disconnect (4).
4. Disconnect electrical cable (5) at connector (6).
5. Remove nut (7), washer (8), and screw (9) from clamp (10).

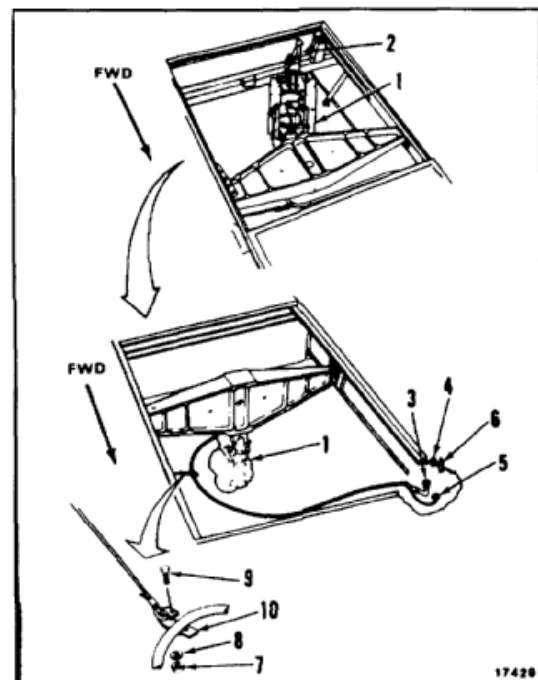
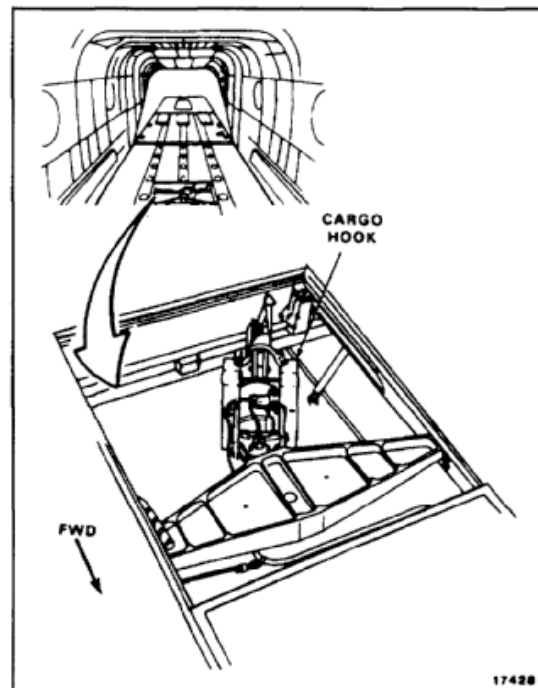

**16-4.1 REMOVE CENTER CARGO HOOK (Continued)**

16-4.1

6. Remove clamp (10) and bungee cord (11) from hose (3) and electrical cable (5).
7. Remove cotter pin (12), washer (13), and straight pin (14) from lever (15).
8. Remove lockwire from jam nut (16). Loosen jam nut (16). Remove cable (17) from hook (1).

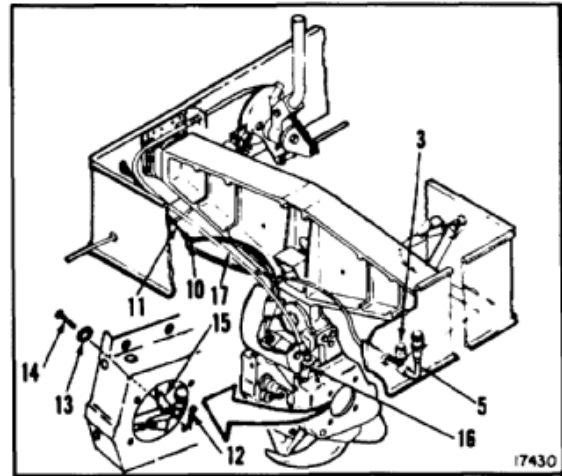

9. Remove two bolts (18) and six washers (19) from guard (20).
10. Remove two bolts (21), four washers (22), and clamps (23) from guard (20).
11. Spread guard (20) to clear bolt (24) and nut (25). Remove guard.

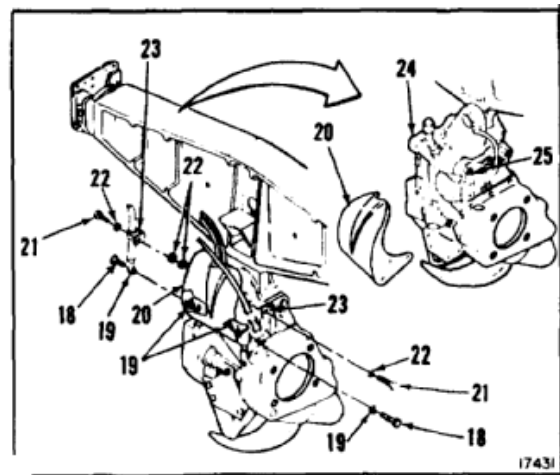

12. Remove cotter pin (26), nut (27), two washers (28), and bolt (29) from cargo hook (1).
13. Have helper support hook (1). Remove sleeve spacer (30).
14. Remove cargo hook (1).

**FOLLOW-ON MAINTENANCE:**

None

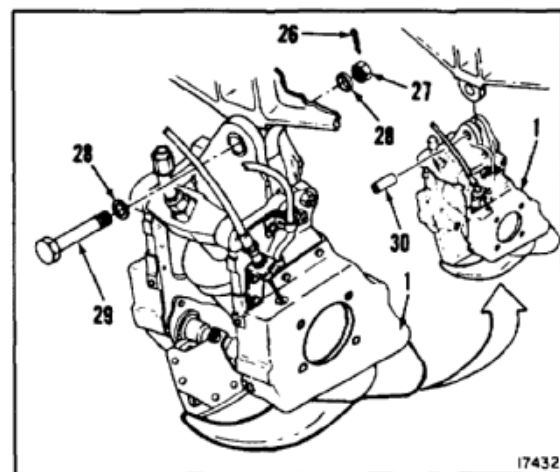

END OF TASK

INITIAL SETUP

**Applicable Configurations:**

Without **35**

**Tools:**

Aircraft Mechanic's Tool Kit, NSN 5180-00-323-4692

**Materials:**

None

**Personnel Required:**

Medium Helicopter Repairer

**References:**

TM 55-1500-322-24

**Equipment Condition:**

Off Helicopter Task

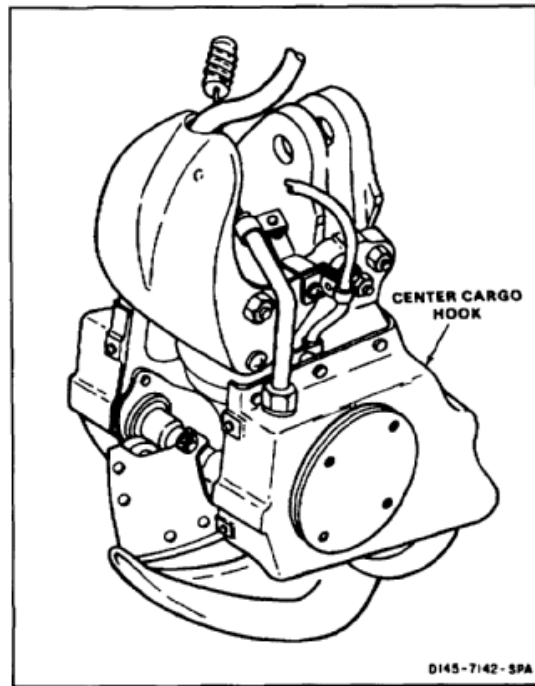

1. Remove four screws (1), washers (2), and access door (3) from cover (4).
2. Remove cotter pin (5) and straight head pin (6) from strap (7). Remove strap (7) from lever (8).

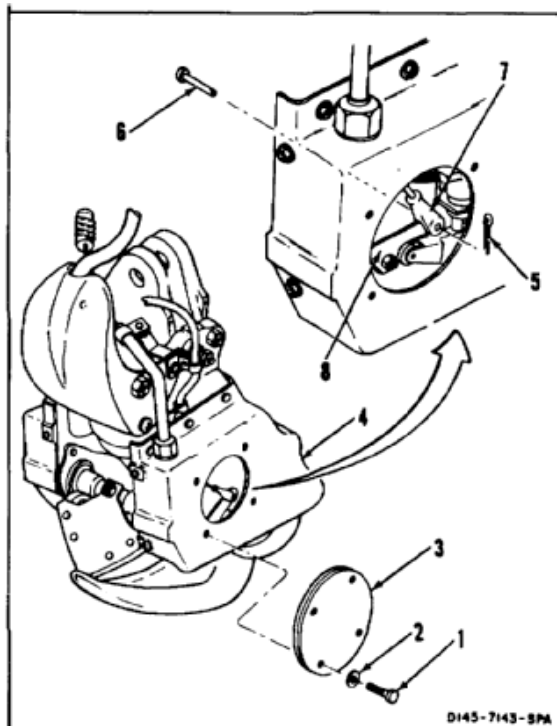

16-5 DISASSEMBLE CENTER CARGO HOOK (AVIM) (Continued)

3. Remove nut (9), washer (10), spacer (11), clamp (12), and bolt (13) from bracket (14).
4. Remove nut (15), washer (16), clamp (17), spacer (18), and screw (19) from cover (4).
5. Remove two nuts (20), washers (21), clamp (22), bracket (23), and screws (24) from guard (25).
6. Remove nut (26), washer (27), clamp (28) and screw (29) from guard (25).

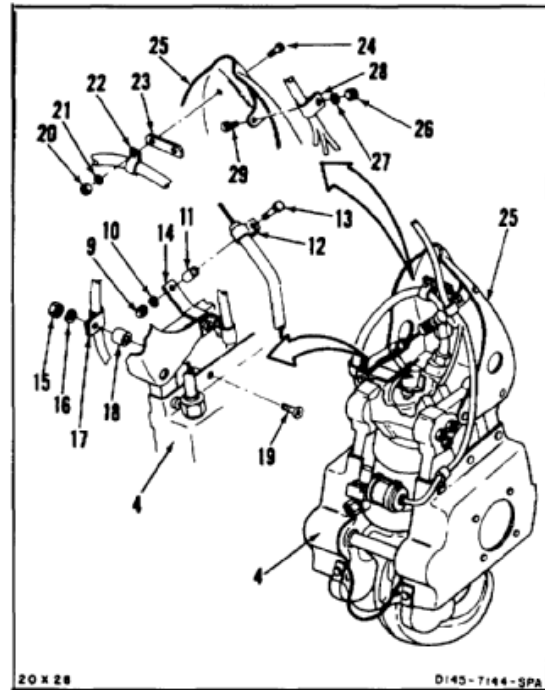

7. Remove bolt (30) and washer (31).
8. Remove cable lock (32) from cable (33).
9. Remove bolt (34), washer (35), and bracket (36) from guard (25).
10. Remove six screws (37), washers (38), plate (39), and strap (40) from cover (4).
11. Remove cover (4) with cable (33).

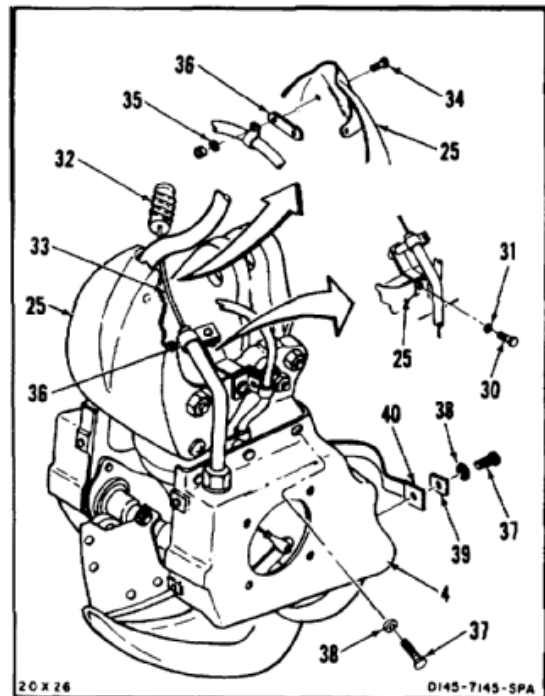

12. Remove bolt (41) and washer (42).
13. Remove bolt (43), washer (44), and bracket (45). Remove guard (25).
14. Remove six screws (46) and washers (47) from cover (48). Remove screw (49), washer (47), plate (50), and strap (40) from cover. Remove cover.

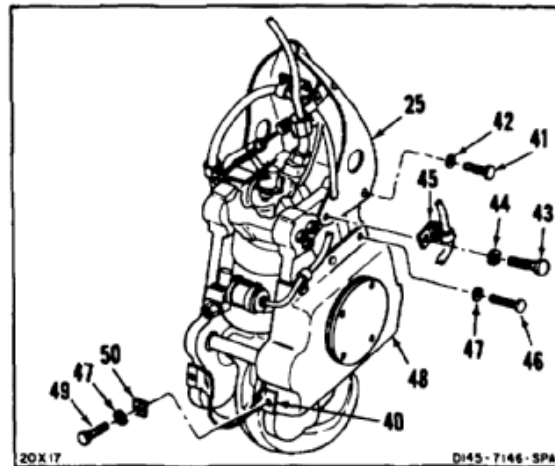

15. Remove hose (51) from actuating cylinder (52).
16. Remove nut (53), washer (54), and bolt (55) from actuating cylinder support (56).
17. Remove three nuts (57), washers (58), and bolts (59) from block (60). Remove block from formers (61 and 62).

**NOTE**

Do not remove bearings unless they are worn.

- 17.1. Remove two bearings (62.1) (TM 55-1500-322-24).

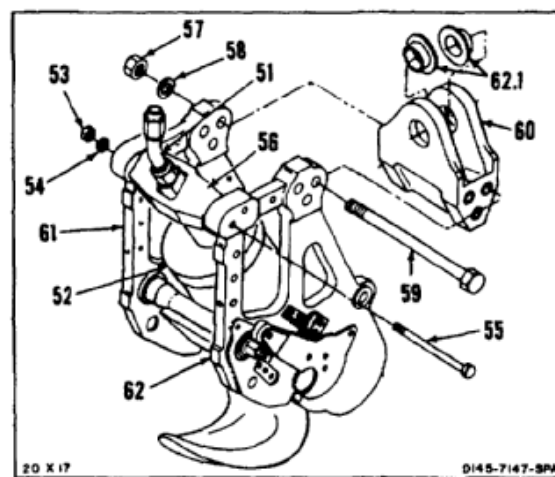

18. Remove two springs (63) from eyebolts (64) and levers (8 and 65).
19. Remove two nuts (66), washers (67), and eye bolts (64) from formers (61 and 62).
20. Remove two nuts (68), washers (69), levers (8 and 65), and cams (70 and 71) from shaft (72).
21. Remove two bolts (73) and bushings (74).

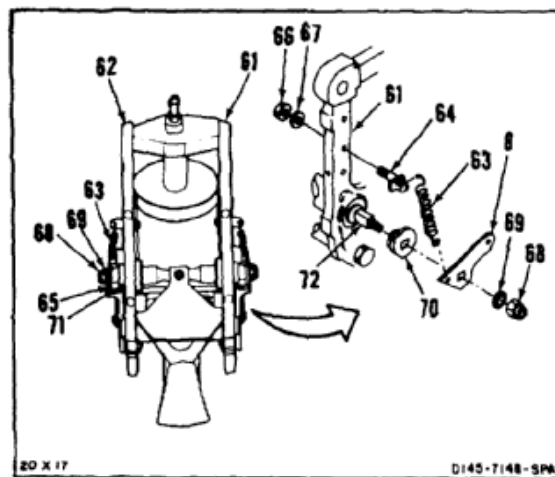

16-5 DISASSEMBLE CENTER CARGO HOOK (AVIM) (Continued)

- 22. Remove two nuts (75), washers (76), and bolts (77) from synchronizer arms (78).
- 23. Remove two synchronizer arms (78), bushings (79), and tube (80) from formers (61 and 52).

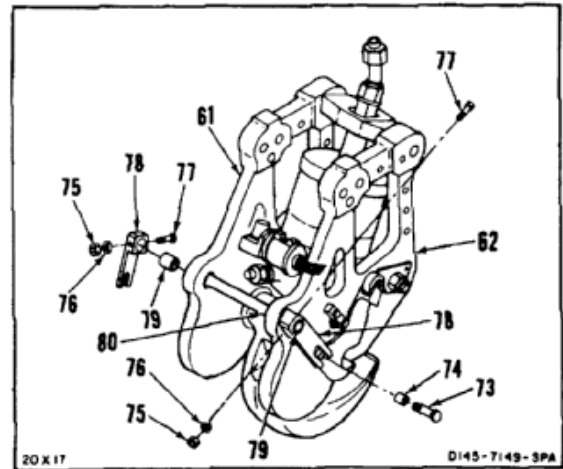

- 24. Remove nut (81), three washers (82), and bolt (83) from keeper (84). Remove keeper, spring (85), and spacer (86).
- 25. Remove lockwire and six bolts (87) from support block (88). Remove support block.

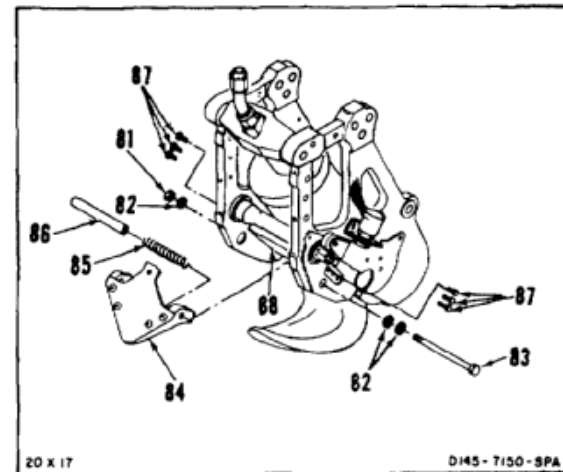

- 26. Remove lockwire, nut (89), washer (90), switch (91), and washer (92) from bracket (93).
- 27. Remove lockwire, nut (94), washer (95), switch (96), and washer (97) from bracket (98).
- 28. If switches (91 and 96) are to be replaced, cut and remove switch wires from wire pack (99).

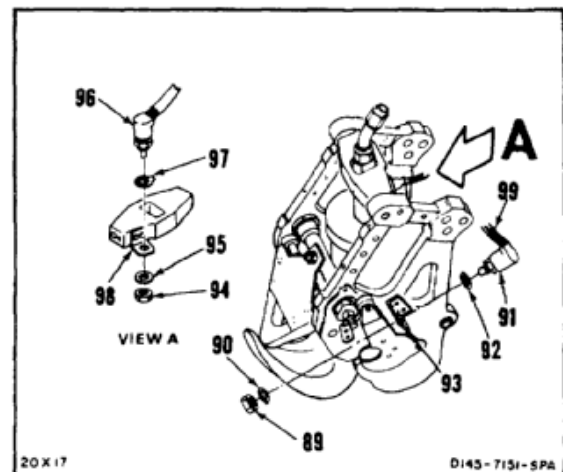

- 29. Remove formers (61 and 62) from actuating cylinder support (56). Use plastic or fiber mallet.
- 30. Remove pin (100) from former (61). Remove shaft (101) and bearings (102 and 103) from former (62).
- 31. Remove bearings (102 and 103) from shaft (101) (TM 55-1500-322-24).

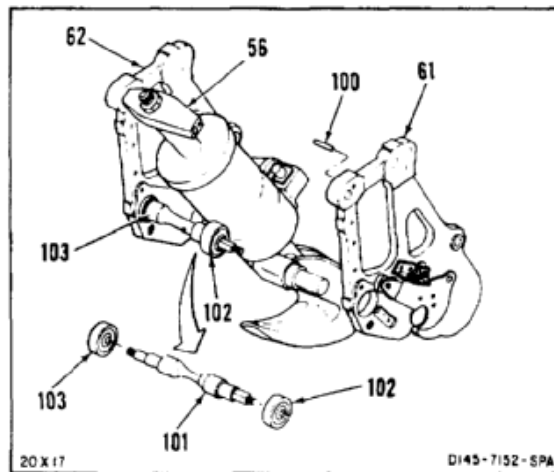

- 32. Remove six bolts (104), two cam plates (105) and two cams (106 and 107) from formers (61 and 62).
- 33. Remove two cotter pins (108), cam bearings pins (109) and cam roller bearing (110) from cams (106 and 107).
- 34. Remove four bolts (111), four washers (112), and two cam stops (113) from formers (61 and 62).

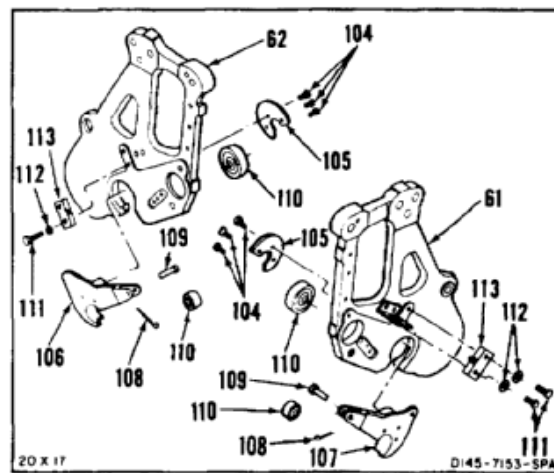

- 35. Remove bolts (114), washers (115), and two cam stops (116) from formers (61 and 62).
- 36. Remove two bolts (117), washers (118), and bracket (93) from former (61).

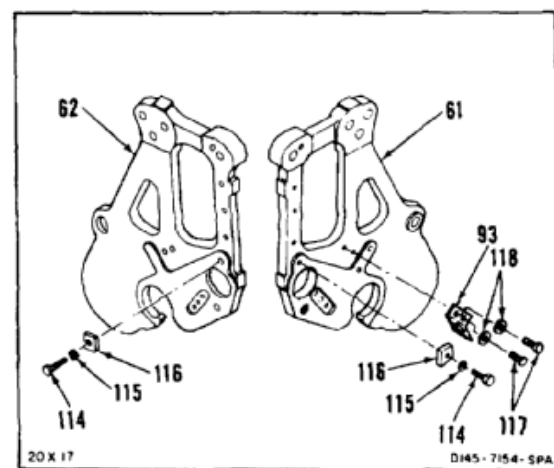



**16-5 DISASSEMBLE CENTER CARGO HOOK (AVIM) (Continued)**

16-5

37. Remove actuating cylinder support (56).
38. Remove two bolts (119), washers (120), and bracket (98) from actuating cylinder support (56).
39. Remove nut (121), washers (122), bolt (123), and hook (124) from actuating cylinder (52).

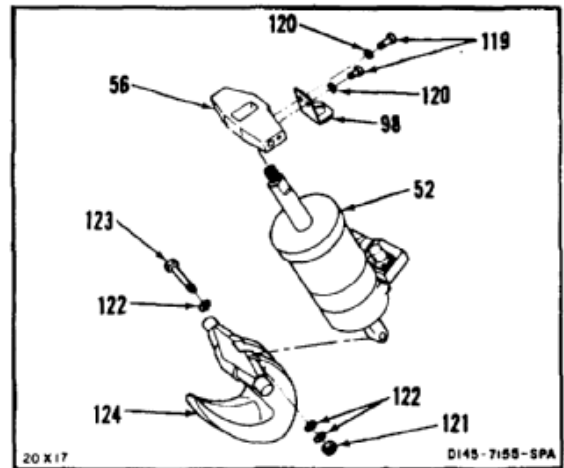
**FOLLOW-ON MAINTENANCE:**

None

END OF TASK

INITIAL SETUP

**Applicable Configurations:**

With **35**

**Tools:**

Aircraft Mechanic's Tool Kit, NSN 5180-00-323-4692

**Materials:**

None

**Personnel Required:**

Medium Helicopter Repairer

**References:**

TM 55-1500-322-24

**Equipment Condition:**

Off Helicopter Task

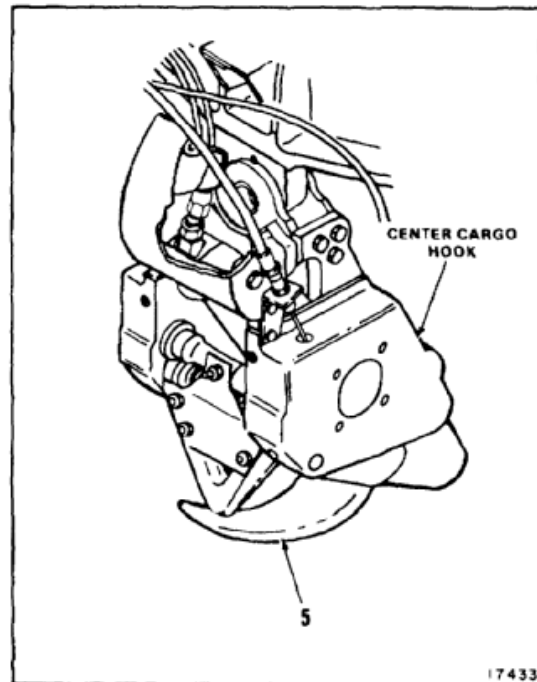

1. Remove nut (1), washer (2), clamp (3), spacer (4), and screw (5) from cover (6).
2. Remove nut (7), washers (8), clamp (9), bracket (10), and screws (11) from guard (12).
3. Remove nut (13), washer (14), clamp (15), and screw (16) from guard (12).

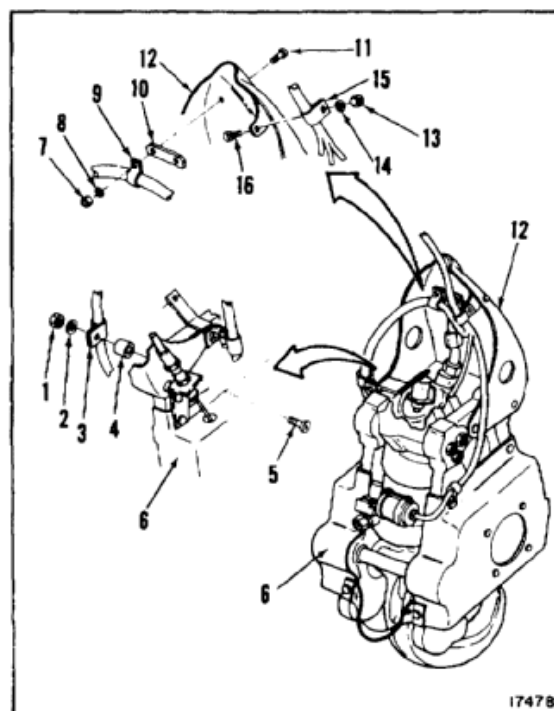

16-5.1 DISASSEMBLE CENTER CARGO HOOK (AVIM) (Continued)

16-5.1

4. Remove two bolts (17), six washers (18), and bracket (19) from cover (6) and guard (12).
5. Remove five screws (20) and washers (21). Remove screw (22), washer (23), and plate (24) from cover (6). Disconnect strap (25) from cover.
6. Remove cover (6).

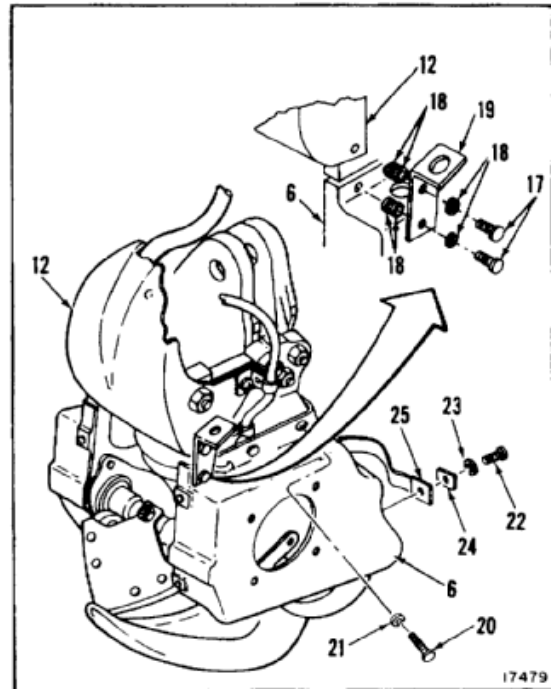

7. Remove bolt (26) and three washers (27).
8. Remove bolt (28), washer (29), and bracket (30). Remove guard (12).
9. Remove screw (31), washer (32), and bracket (33) from cover (34).
10. Remove five screws (35) and washers (36) from cover (34). Remove screw (37), washer (38), plate (39), and strap (40) from cover. Remove cover.

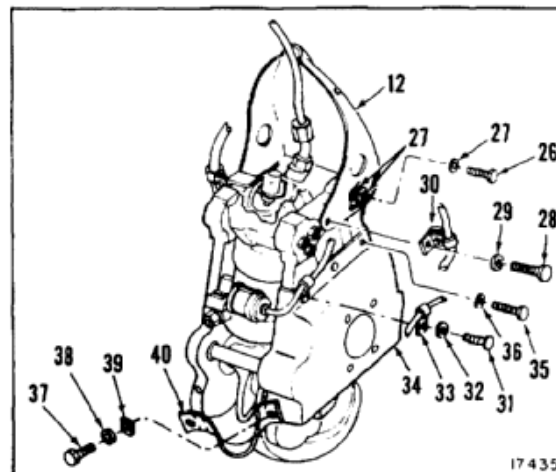

11. Remove hose (41) from actuating cylinder (42).
12. Remove nut (43), washer (44), and bolt (45) from actuating cylinder support (46).

**NOTE**

Do not remove bearings unless they are worn.

13. Remove three nuts (47), washers (48), and bolts (49) from block (50). Remove block from formers (51 and 52). Remove two bearings (53) (TM 55-1500-322-24).

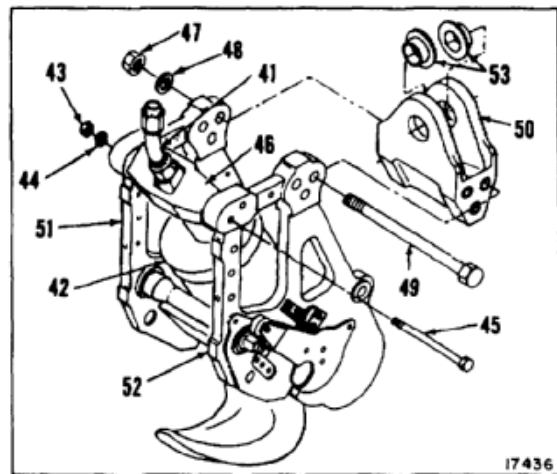

14. Remove two springs (54) from eyebolts (55) and levers (56 and 57).
15. Remove two nuts (58), washers (59), and eyebolts (55) from formers (51 and 52).
16. Remove two nuts (60), washers (61), levers (56 and 57), and cams (62 and 63) from shaft (64).

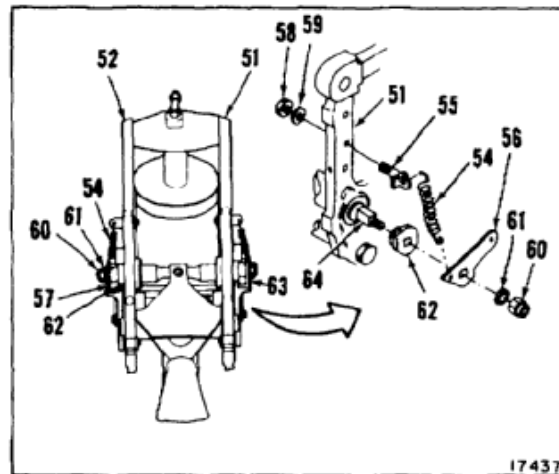

17. Remove two bolts (65) and bushings (66).
18. Remove two nuts (67), washers (68), and bolts (69) from synchronizer arms (70 and 71).
19. Remove two synchronizer arms (70 and 71), bushings (72), and tube (73) from formers (51 and 52).

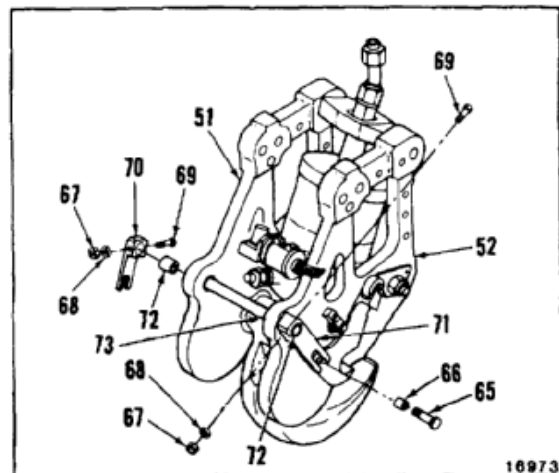

16-5.1 DISASSEMBLE CENTER CARGO HOOK (AVIM) (Continued)

16-5.1

- 20. Remove nut (74), three washers (75), and bolt (76) from keeper (77). Remove keeper, spring (78), and spacer (79).
- 21. Remove lockwire and six bolts (80) from support block (81). Remove support block.

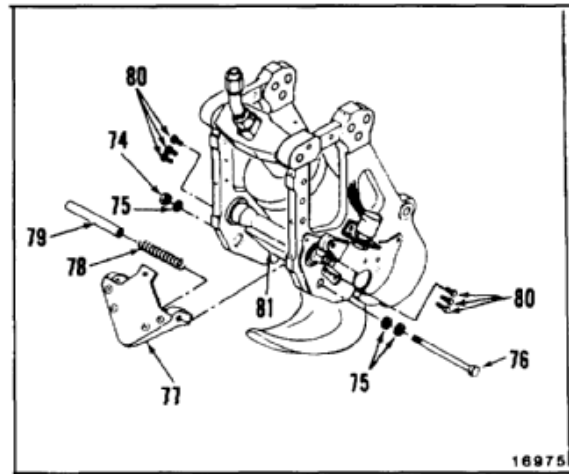

- 22. Remove lockwire, nut (82), washer (83), switch (84), and washer (85) from bracket (86).
- 23. Remove lockwire, nut (87), washer (88), switch (89), and washer (90) from bracket (91).
- 24. If switches (84 and 89) are to be replaced, cut and remove switch wires from wire pack (92).

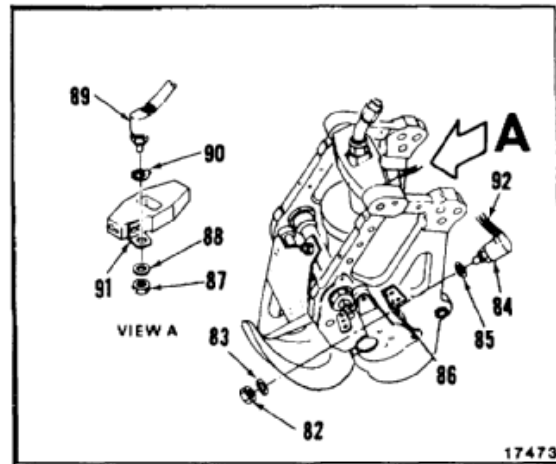

- 25. Remove formers (51 and 52) from actuating cylinder support (46). Use plastic or fiber mallet.
- 26. Remove pin (93) from former (51). Remove shaft (94) and bearings (95 and 96) from former (52).
- 27. Remove bearings (95 and 96) from shaft (94) (TM 55-1500-322-24).

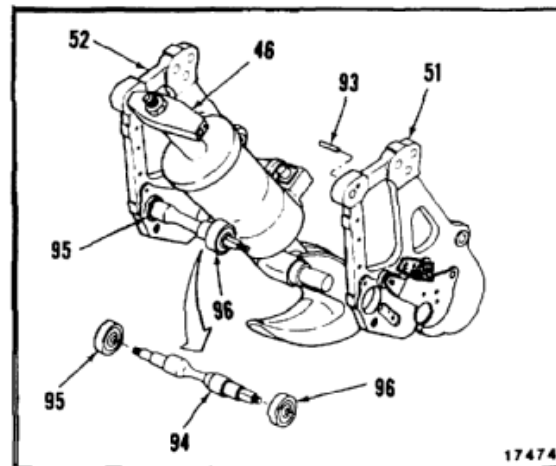

- 28. Remove six bolts (97), two cam plates (98), and two cams (99 and 100) from formers (51 and 52).
- 29. Remove two cotter pins (101), cam bearings pins (102), and cam roller bearing (103) from cams (99 and 100).
- 30. Remove four bolts (104), four washers (105), and two cam stops (106) from formers (51 and 52).

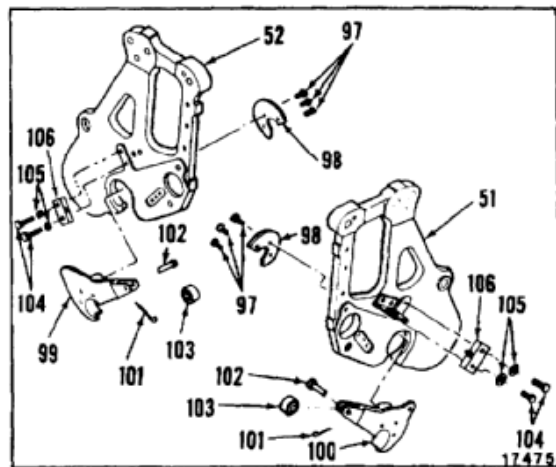

- 31. Remove bolts (107), washers (108), and two cam stops (109) from formers (51 and 52).
- 32. Remove two bolts (110), washers (111), and bracket (86) from former (54).

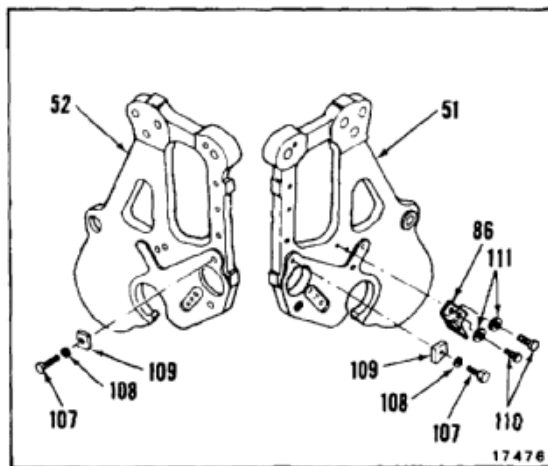

- 33. Remove actuating cylinder support (46).
- 34. Remove two bolts (112), washers (113), and bracket (91) from actuating cylinder support (46).
- 35. Remove nut (114), washers (115), washer (116), bolt (117), and hook (118) from actuating cylinder (42).

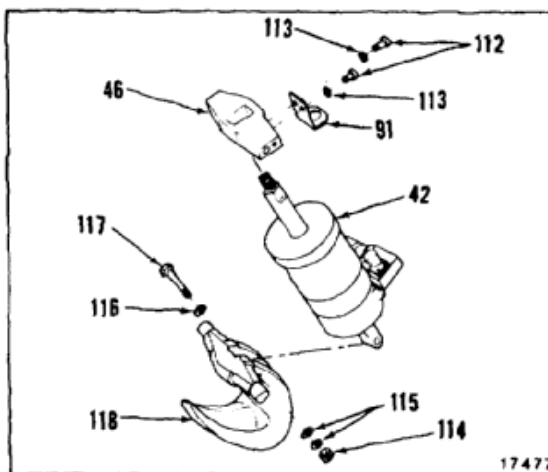

**FOLLOW-ON MAINTENANCE:**

None

END OF TASK

INITIAL SETUP

**Applicable Configurations:**

All

**Tools:**

Technical Inspector Tool Kit, NSN 5180-00-323-5114  
Multimeter

**Materials:**

None

**Personnel Required:**

Inspector

**References:**

TM 55-1500-322-24  
TM 1-1520-254-23

**Equipment Condition:**

Off Helicopter Task  
Center Cargo Hook Disassembled (Task 16-5 Without **35**) (Task 16-5.1 With **35**)

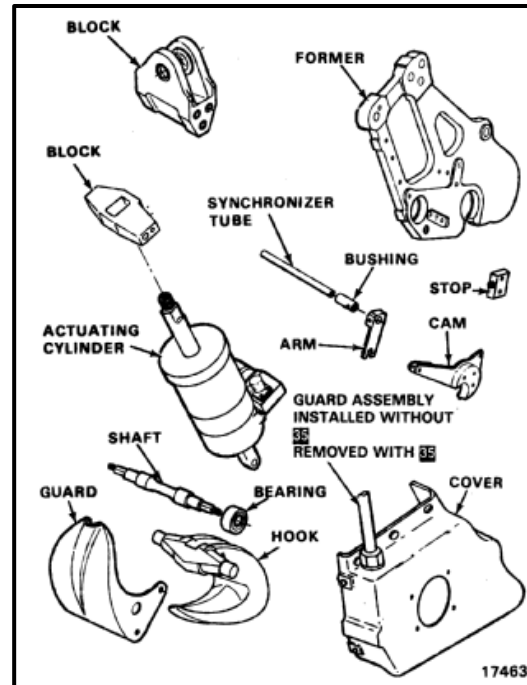

**NOTE**

Inspection steps cover parts that are subject to wear.

1. Check synchronizer tube (1), two bushings (2), and two synchronizer arms (3) for bending and distortion.
2. Measure diameter of tube (1). Diameter shall not be less than **0.409 inch**.
3. Measure inside and outside diameters of bushings (2). OD shall not be less than **0.718 inch**. ID shall not be more than **0.410 inch**.
4. Measure width of slot (3) and diameter of hole (4) in two arms (5). Width shall not be more than **0.321 inch**. Diameter shall not be more than **0.721 inch**.

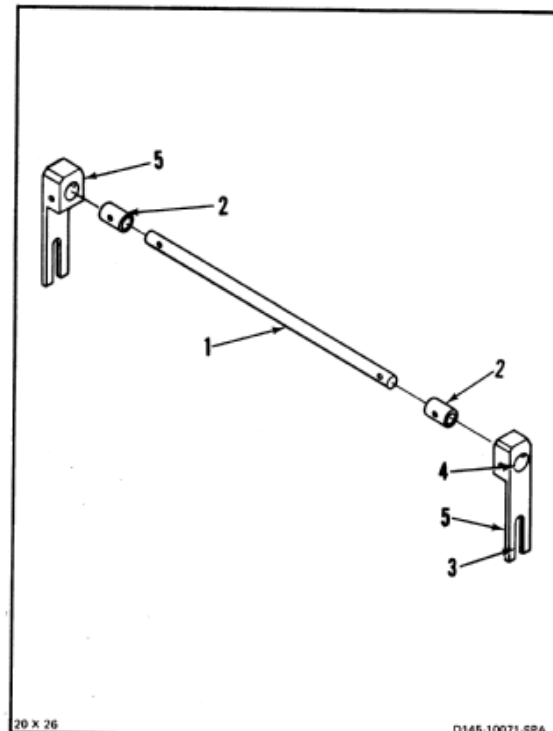

5. Check actuating cylinder (6) for leaks or damage. Check cylinder emergency release valve (7) for loose or missing screws.

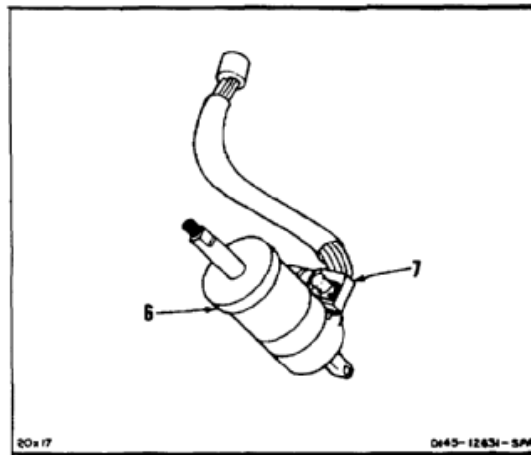

6. Check two cam stops (8) for security of hardware and damage to tip of setscrew (9).
7. Check two large cams (10) for galling on circumference of chromium plated surface and for damage from striking setscrew (9).
8. Measure width of throat (11) in cams (10). Width shall not be more than **1.014 inches**.
9. Measure diameter of bores (12) in cams (10). Diameters shall not be more than **0.501 inch**.

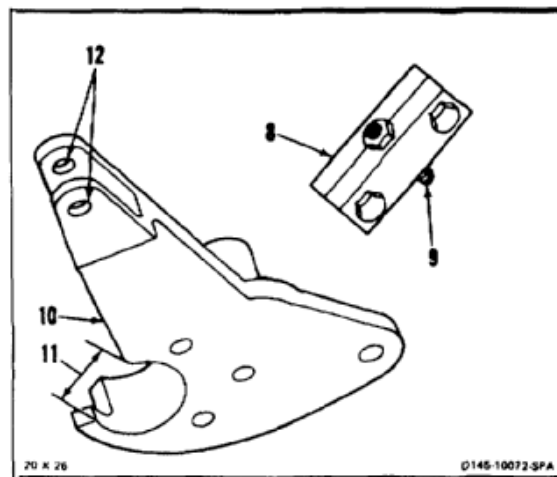

10. Check two formers (13) in area of bore (14). There shall be no galling, cracks, or distortion.
11. Fit cams (10) into bores (14). Cams shall rotate freely.
12. Measure diameter of bore (14). Diameter shall not be more than **2.322 inches**, except in shaded area. Diameter across shaded area shall not be more than **2.327 inches**.
13. Inspect cam plates (15). Cam plates shall not be bent.

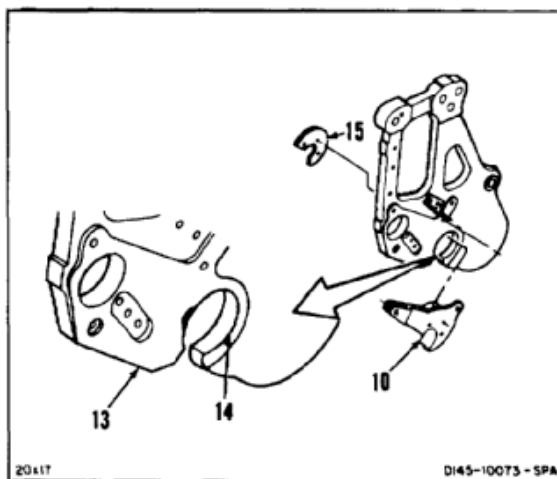



**16-6 INSPECT CENTER CARGO HOOK PARTS AVIM (Continued)**

16-6

- 14. Inspect two bushings (16). Teflon liner shall not be torn or worn through.
- 15. Measure two bores (17) in block (18). Diameter shall not be more than **1.188 inches**.
- 16. Measure inside diameter of six bushings (19). Diameter shall not be more than **0.502 inch**.
- 17. Measure width of block (18). Width shall not be less than **4.995 inches**.
- 18. Measure diameter of bolts (20). Diameter shall not be less than **0.499 inch**.

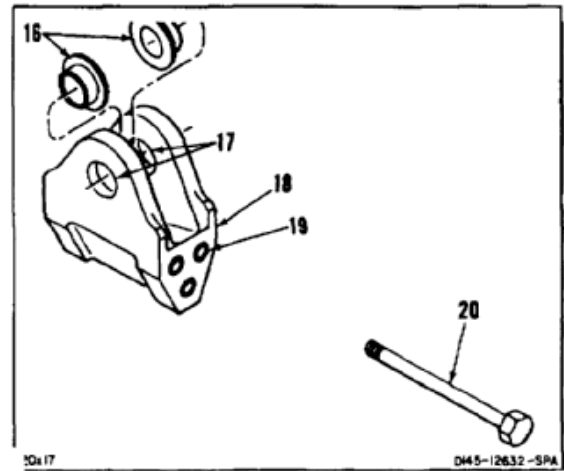

- 19. Inspect bearings (21) (TM 55-1500-322-24).
- 20. Inspect shaft (22). Shaft shall not be bent.
- 21. Measure diameter of bearing surfaces of shaft (22). Diameter shall not be less than **0.749 inch**.
- 22. Inspect two cams (23). Corners of cams shall not be rounded.
- 23. Measure inside and outside diameter of spacer (24). Inspect spacer (24) for evidence of excessive wear. Nominal dimension of spacer is **3.750 inches** in length, **0.277 inch ID** and **0.375 inch OD**.

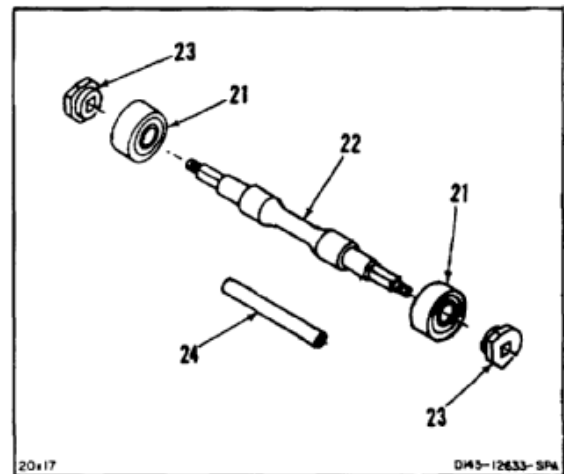

- 24. Check two electrical switches (25) for continuity. Use multimeter.
- 25. Check plug connector (26) and electrical cable (27) for fraying.
- 26. Check emergency release cable (28) for fraying.

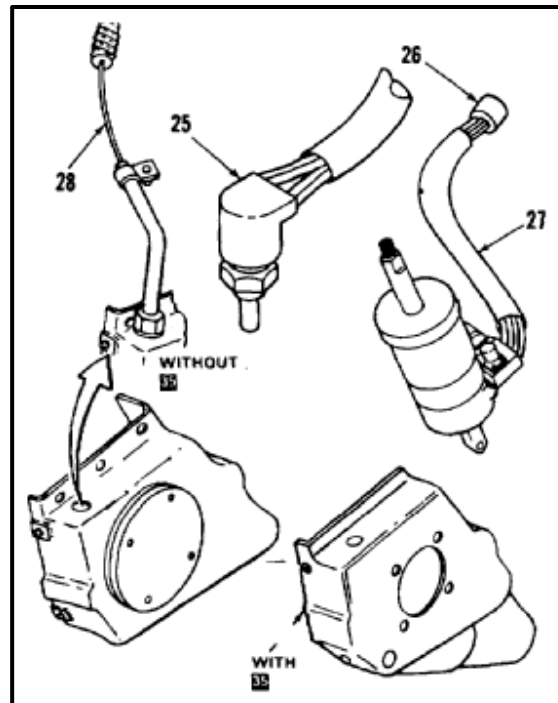

- 27. Inspect hook (29) for cracks and distortion. If a crack in the cargo hook is suspected, refer to TM 1-1520-253-23.
- 28. Measure diameter of two lugs (30). Diameter shall not be less than **0.990 inch**.

**NOTE**

Access door (33) is removed with **35**.

- 29. Check guard (31), two covers (32), and access door (33) for cracks and for elongated or damaged screw holes.
- 30. Measure diameter of four holes (34) in guard (31). Diameter shall not be more than **0.288 inch**.

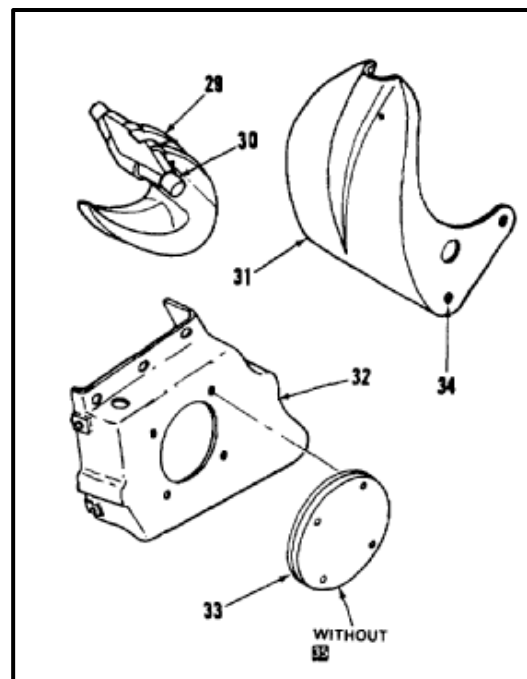

**FOLLOW-ON MAINTENANCE:**

None

END OF TASK

INITIAL SETUP

**Applicable Configurations:**

Without 35

**Tools:**

- Aircraft Mechanic's Tool Kit, NSN 5180-00-323-4692
- Arbor Press
- Torque Wrench, 100 to 750 Inch-Pounds
- Torque Wrench, 5 to 50 Inch-Pounds

**Materials:**

Lockwire (E231)

**Parts:**

Cotter Pins

**Personnel Required:**

- Medium Helicopter Repairer
- Inspector

**References:**

- TM 55-1500-322-24
- TM 55-1520-240-23P

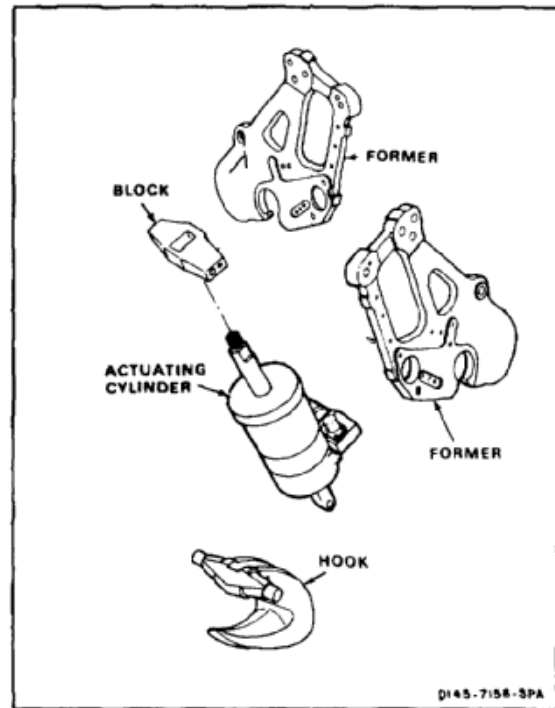

1. Position hook (1) on actuating cylinder (2). Install bolt (3), one washer (4) under bolt-head, two washers (4.1) under nut (5), and nut.
2. Install bracket (6), two washers (7), and two bolts (8) on actuator support (9).
3. Install actuator support (9) on actuating cylinder (2).

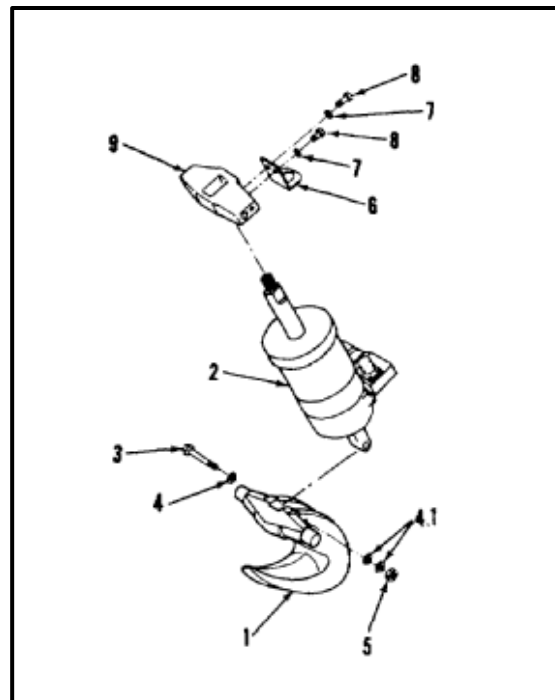

**CAUTION**

Do not hammer bearings into formers. Damage to bearings and formers will result.

4. Install bearings (10 and 11) in formers (12 and 13) (TM 55-1500-322-24). Use arbor press.
5. Install bracket (14) with two washers (15) and two bolts (16) on former (12).
6. Install two stops (17) with two washers (18) and two bolts (19) on formers (12 and 13).

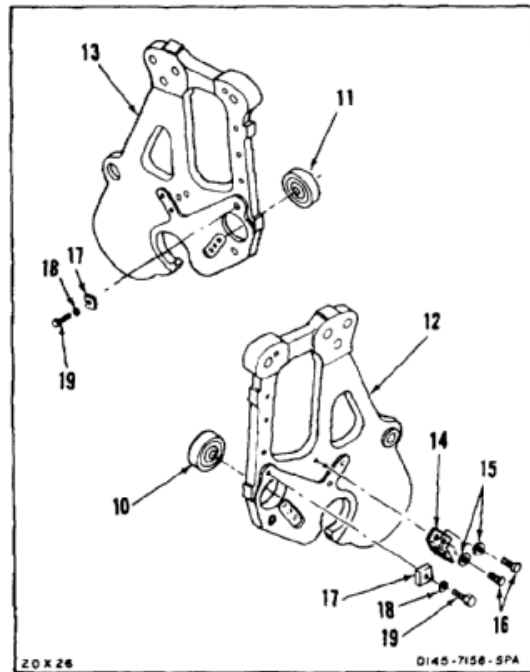

7. Install two cam stops (20) with four washers (21) and four bolts (22) on formers (12 and 13).
8. Position two cam roller bearings (23) in forks of two cams (24 and 25). Install two cam bearing pins (26) and cotter pins (27).

**CAUTION**

Cams and cam plates must be installed correctly or cargo hook will not function.

9. Install two cams (24 and 25), two cam plates (28), and six bolts (29) on formers (12 and 13).

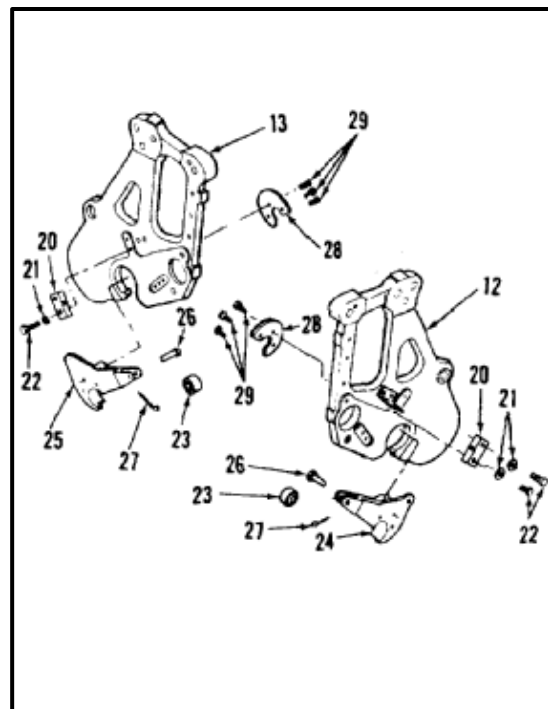

10. Install three bolts (30) and support block (31) on former (13). Do not tighten bolts at this time.
11. Insert one end of shaft (32) in bearing (11).
12. Position actuating cylinder (2), so that machined spindle on hook (1) fits into slot in cam (25).



Do not hammer alignment pin into former. If end of pin becomes enlarged it will not fit in actuator support.

13. Install alignment pin (33) in former (12). Use arbor press.
14. Position former (12) on actuating cylinder (2) so that shaft (32) aligns with bearing (10). Alignment pin (33) engages actuator support (9) and machined spindle on hook fits into slot in cam (24).
15. Lightly tap former (12) into place with plastic or fiber mallet.

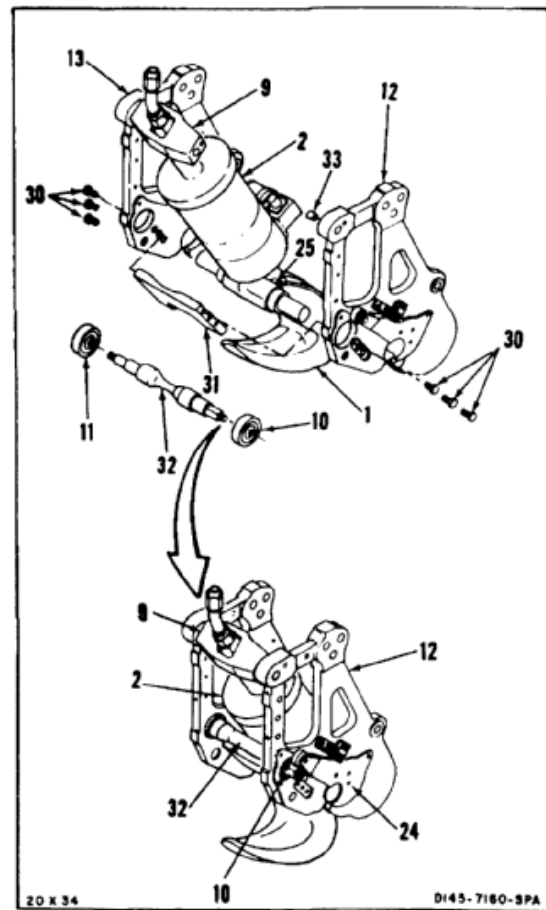

16. Install three bolts (30) through former (12) into support block (31). Do not tighten bolts at this time.
- 16.1. Install two bearings (33.1) (TM 55-1500-322-24).
17. Position block (34) between formers (12 and 13). Install three bolts (35), washers (36), and nuts (37). Do not tighten nuts at this time.
18. Align holes in formers (12 and 13) and actuator support (9). Install bolt (38), washer (39), and nut (40). Do not tighten nut at this time.

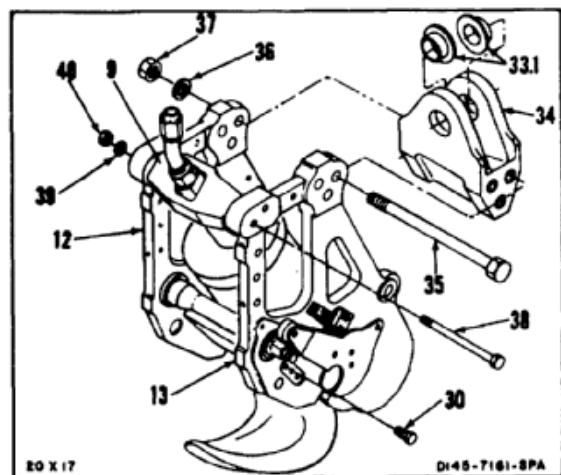

19. Install spacer (41) in spring (42).
20. Insert end of spring (42) in hole in keeper (43). Insert other end of spring in hole in support block (31).
21. Align holes in formers (12 and 13), keepers (43), and spacer (41). Install bolt (44), three washers (45), and nut (46).

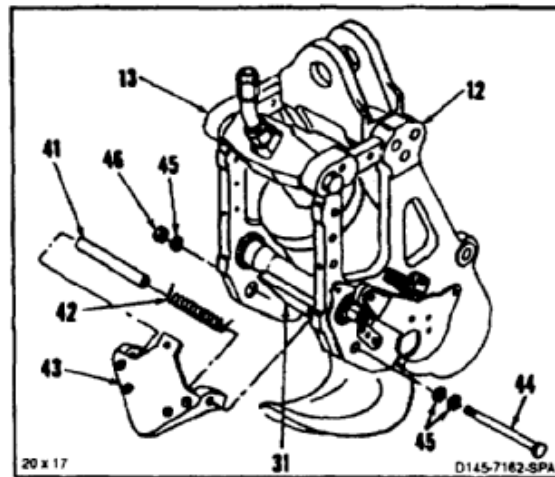

22. Carefully tighten six bolts (39) and nuts (37 and 40), so that formers (12 and 13) pull together squarely. Torque six bolts (30) to **200 inch-pounds**. Lockwire bolts. Use lockwire (E231).

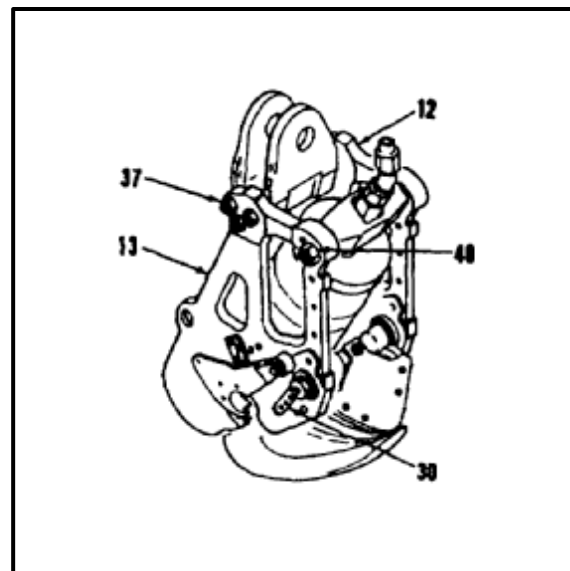

23. Position bushing (47) and synchronizing arm (48) on tube (49) so that bolt holes align. Install bolt (50), washer (51), and nut (52). Torque nut to **30 inch-pounds**.
24. Slide tube (49) through holes in formers (12 and 13).
25. Position bushing (53) and synchronizing arm (54) on tube (49) so that bolt holes align. Install bolt (55), washer (56), and nut (57). Torque nut to **30 inch-pounds**.

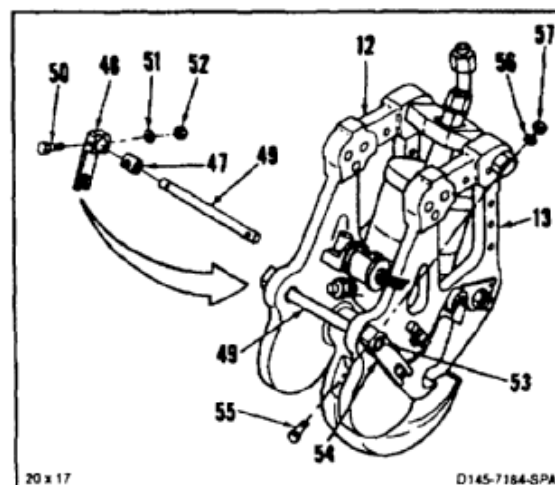

## 16-7 ASSEMBLE CENTER CARGO HOOK AVIM (Continued)

16-7

26. Install two eyebolts (58), washers (59), and nuts (60) in formers (12 and 13).
27. Position cams (61 and 62), rounded surface facing toward tube (49), on squared section of shaft (32).
28. Install levers (63 and 64), washers (65), and two nuts (66) on shaft (32).
29. Connect two springs (67) to eyebolts (58) and levers (63 and 64).

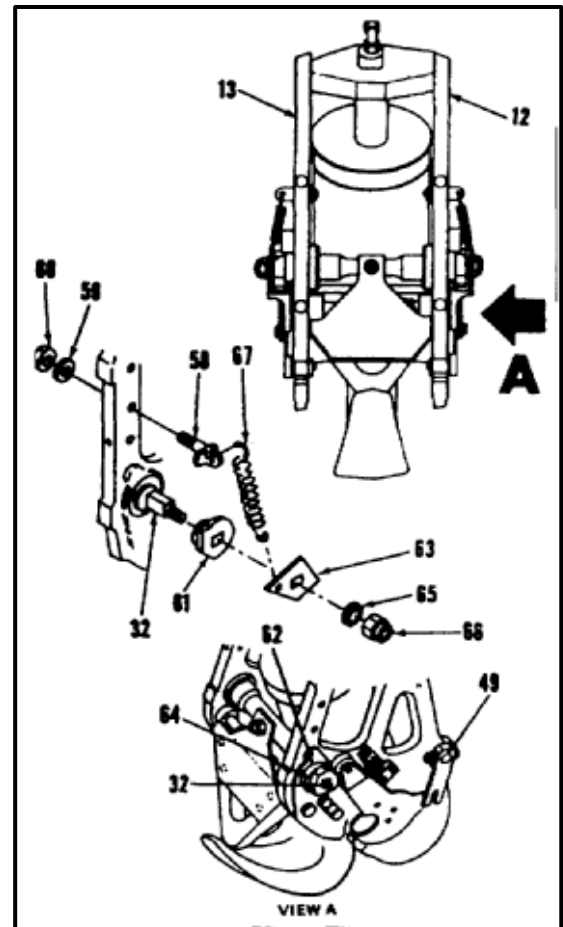

30. Rotate synchronizer arms (48 and 54) over holes in cams (24 and 25). Install two bushings (67) and bolts (68) through forks, in synchronizing arms into cams.
31. Adjust keeper stop (69) as follows:
  - a. Remove lockwire from locknut (70). Loosen locknut.
  - b. Adjust keeper stop (69) so that keeper contacts or is within **0.06 inch** of hook (1).
  - c. Tighten locknut (70). Lockwire locknut. Use lockwire (E231).

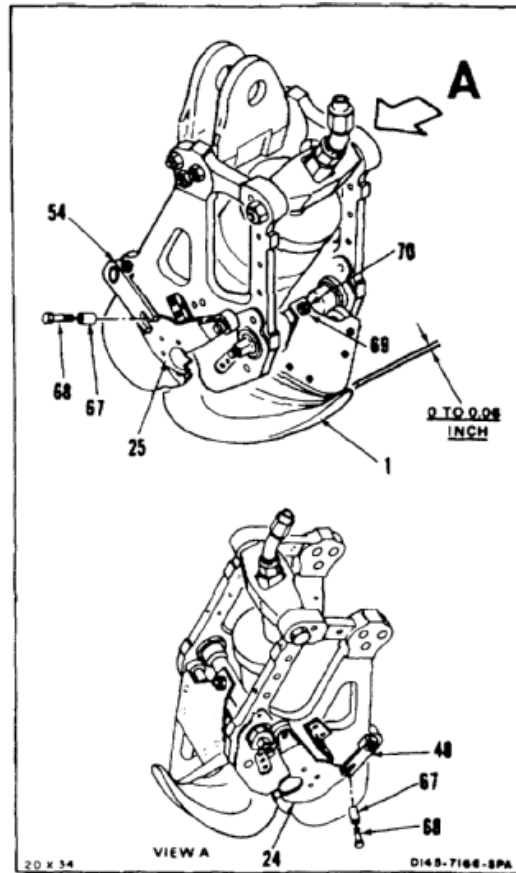

32. Adjust cam stops (20) as follows:
  - a. Lift lever (63) and rotate cams (24 and 25) until they contact stop screws (71).
  - b. Loosen locknuts (72).
  - c. Adjust stop screws (71) until lower edge of cut out in cams (24 and 25) is **0.01 to 0.09 inch** above lower edge of cut out in formers (12 and 13).
  - d. Tighten locknuts (72).

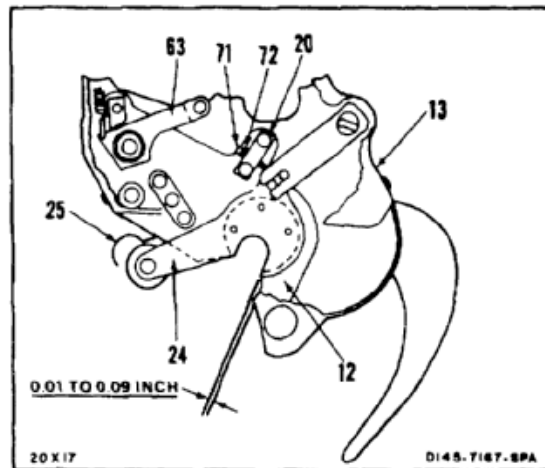



- 33. Install switch (73), two washers (74), and nut (75) in bracket (6).
- 34. Install switch (76), two washers (77), and nut (78) in bracket (14).

**NOTE**

Switches are lockwired after adjustment (Task 16-7.2).

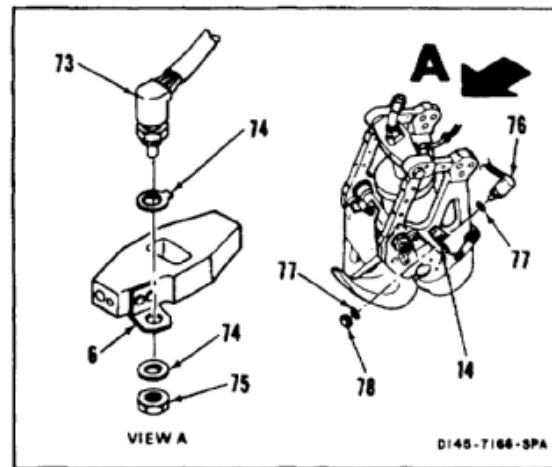

- 35. Position cover (79) on former (13). Install six screws (80), washers (81), bracket (82), plate (83), and strap (84).
- 36. Install hose (85) on actuating cylinder (2).

**NOTE**

Guard will be removed prior to installation. It is temporarily installed to prevent loss of hardware.

- 37. Position guard (86) on formers (12 and 13). Temporarily install bolts (87 and 88), washers (89), and clamp (90).

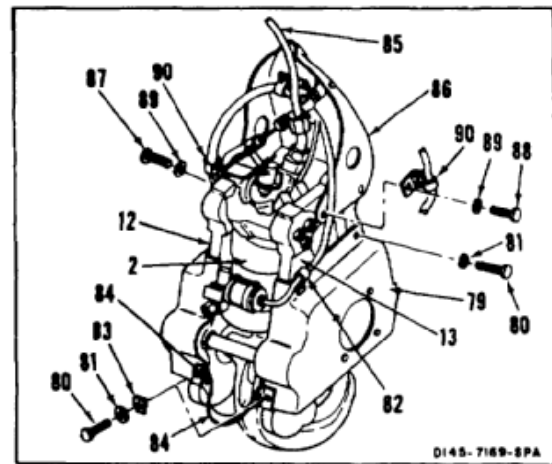

- 38. Position cover (92) with cable (93) on former (12). Install five screws (94) and washers (95). Install screw (96), washer (95), plate (97), and strap (84).

**NOTE**

Guard will be removed prior to installation. It is temporarily installed to prevent loss of hardware.

- 39. Position bracket (98) between guard (87) and former (12). Temporarily install two bolts (99 and 100), washers (101), and bracket (102).
- 40. Install cable lock (103) on cable (93).

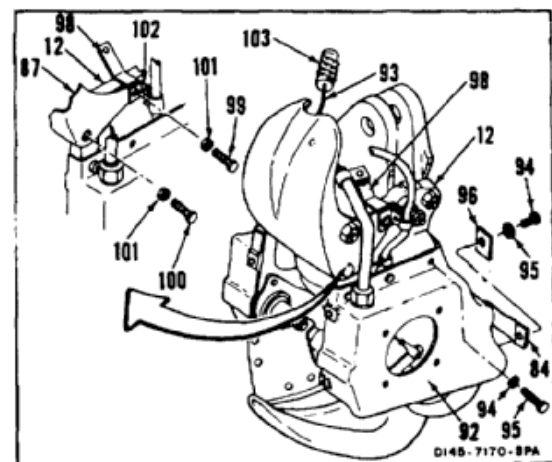

41. Install screw (104), spacer (105), clamp (106), washer (107), and nut (108) on cover (92).
42. Install screw (109), clamp (110), spacer (110.1), washer (111), and nut (112) on bracket (113).
43. Temporarily install two screws (114), bracket (115), clamp (116), washers (117), and nuts (118) on guard (87).
44. Temporarily install screw (119), clamp (120), washer (121), and nut (122) on guard (87).

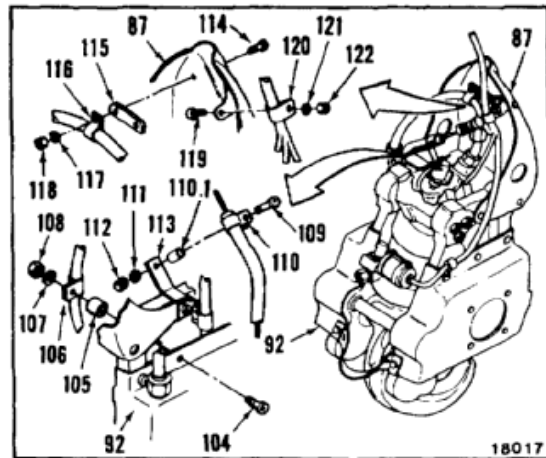

45. Align holes in strap (123) and lever (63). Install straight head pin (124) and cotter pin (125).

**NOTE**

Cover (126) is not to be installed.  
Discard cover.

**INSPECT**

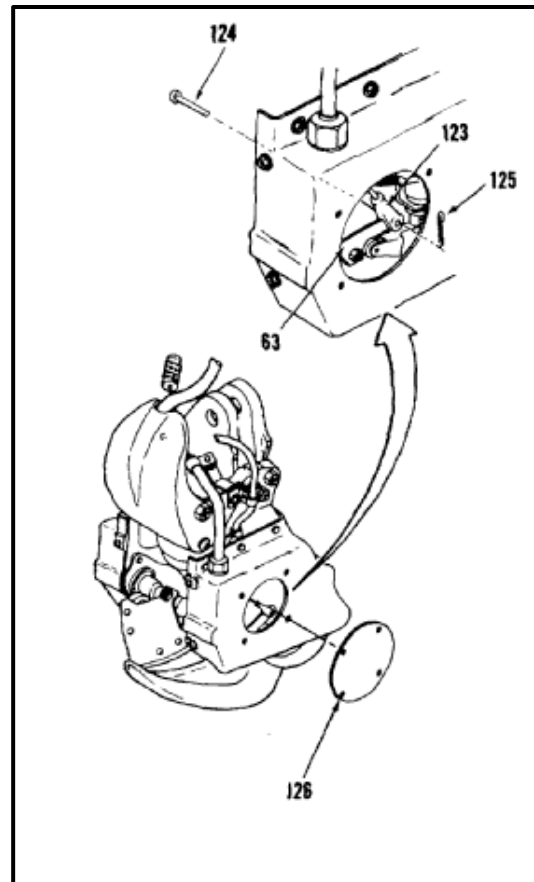

**FOLLOW-ON MAINTENANCE:**

Test center cargo hook (Task 16-7.1.1).  
Adjust switches (Task 16-7.2).

END OF TASK

INITIAL SETUP

**Applicable Configurations:**

With **35**

**Tools:**

- Aircraft Mechanic's Tool Kit, NSN 5180-00-323-4692
- Arbor Press
- Torque Wrench, 100 to 750 Inch-Pounds
- Torque Wrench, 5 to 50 Inch-Pounds

**Materials:**

Lockwire (E231)

**Parts:**

Cotter Pins

**Personnel Required:**

- Medium Helicopter Repairer
- Inspector

**References:**

- TM 55-1500-322-24
- TM 55-1520-240-23P

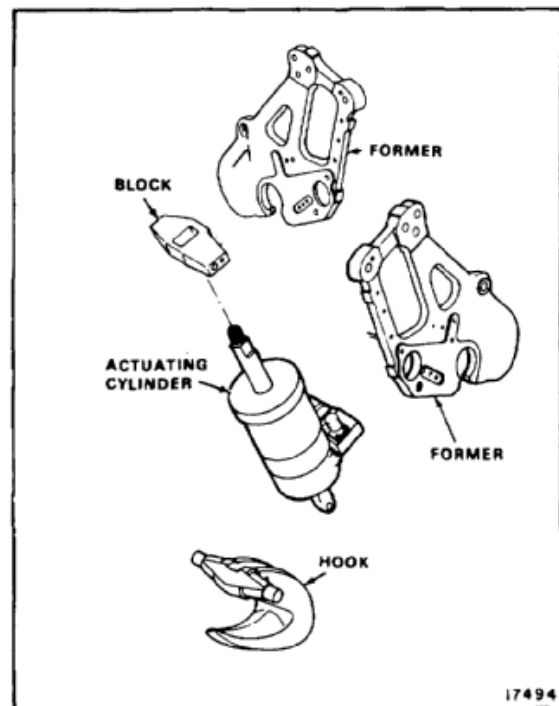

1. Position hook (1) on actuating cylinder (2). Install bolt (3), one washer (4) under bolthead and two washers (5) under nut (6), and nut.
2. Install bracket (7), two washers (8), and two bolts (9) on actuator support (10).
3. Install actuator support (10) on actuating cylinder (2).

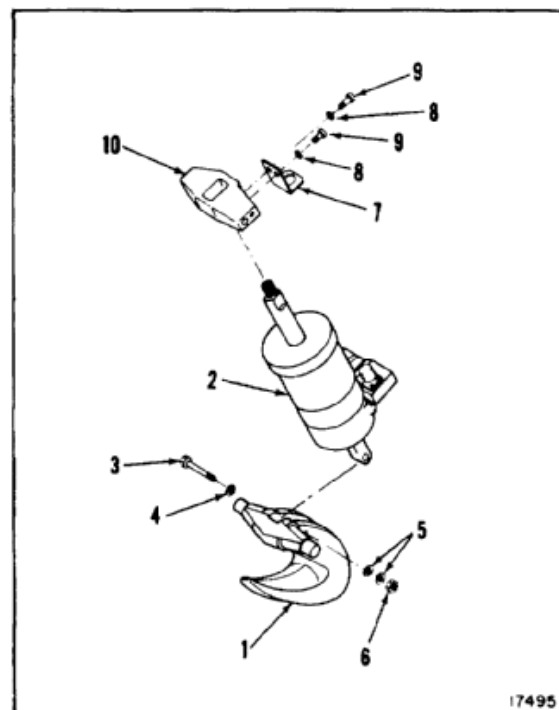

**CAUTION**

Do not hammer bearings into formers. Damage to bearings and formers will result.

4. Install bearings (11 and 12) in formers (13 and 14) (TM 55-1500-322-24). Use arbor press.
5. Install bracket (15) with two washers (16) and two bolts (17) on former (13).
6. Install two stops (18) with two washers (19) and two bolts (20) on formers (13 and 14).

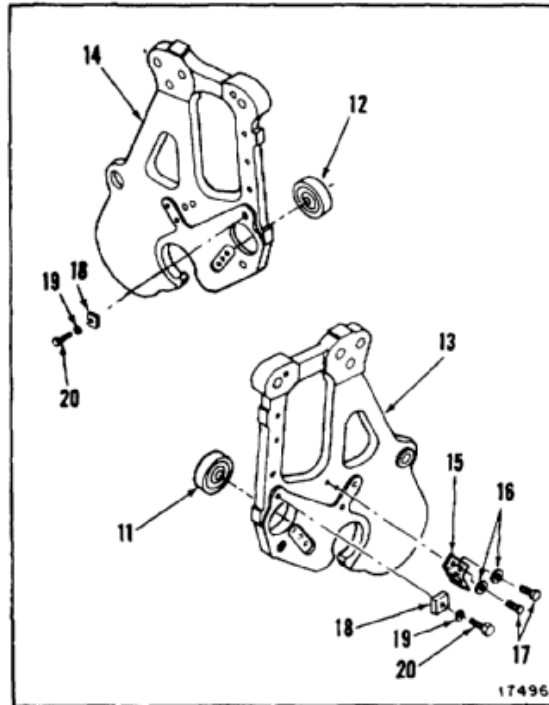

7. Install two cam stops (21) with four washers (22) and four bolts (23) on formers (13 and 14).
8. Position two cam roller bearings (24) in forks of two cams (25 and 26). Install two cam bearing pins (27) and cotter pins (28).

**CAUTION**

Cams and cam plates must be installed correctly or cargo hook will not function.

9. Install two cams (25 and 26), two cam plates (29), and six bolts (30) on formers (13 and 14).

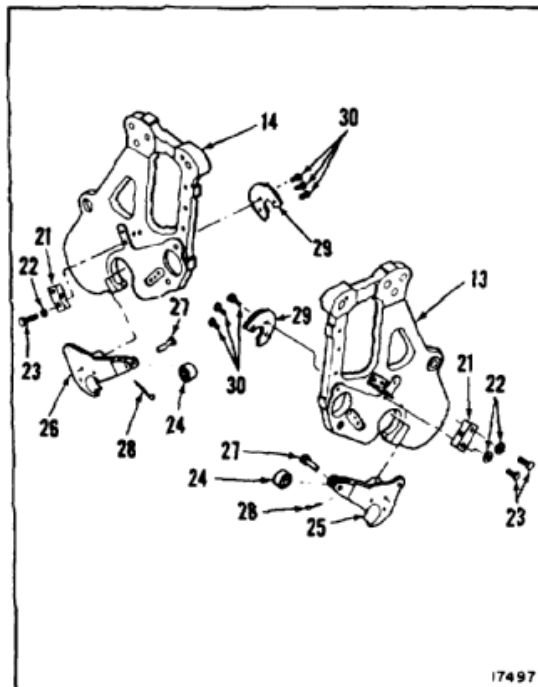

## 16-7.1 ASSEMBLE CENTER CARGO HOOK (AVIM) (Continued)

16-7.1

10. Install three bolts (31) and support block (32) on former (14). Do not tighten bolts at this time.
11. Insert one end of shaft (33) in bearing (12).
12. Position actuating cylinder (2), so that machined spindle on hook (1) fits into slot in cam (26).



Do not hammer alignment pin into former. If end of pin becomes enlarged, it will not fit in actuator support.

13. Install alignment pin (34) in former (13). Use arbor press.
14. Position former (13) on actuating cylinder (2) so that shaft (33) aligns with bearing (11), alignment pin (34) engages actuator support (10) and machined spindle on hook fits into slot in cam (25).
15. Lightly tap former (13) into place with plastic or fiber mallet.
16. Install three bolts (31) through former (13) into support block (32). Do not tighten bolts at this time.

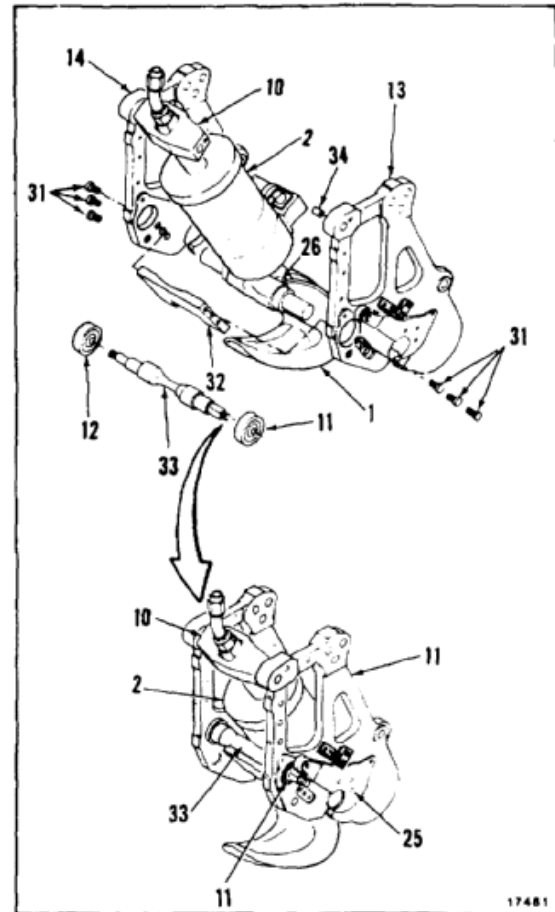

17. Install two bearings (35) (TM 55-1500-322-24).
18. Position block (36) between formers (13 and 14). Install three bolts (37), washers (38), and nuts (39). Do not tighten nuts at this time.
19. Align holes in formers (13 and 14) and actuator support (10). Install bolt (40), washer (41), and nut (42). Do not tighten nut at this time.

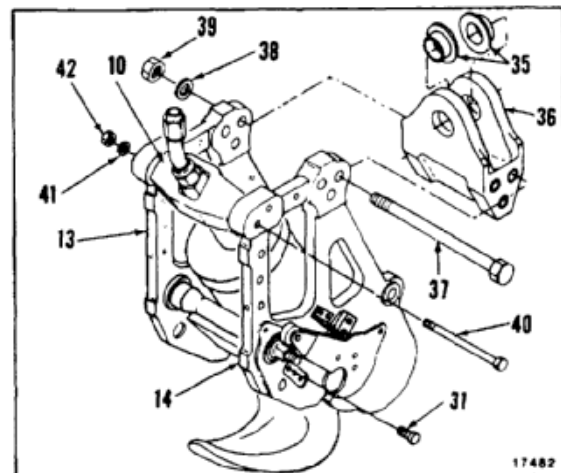

20. Install spacer (43) in spring (44).
21. Insert end of spring (44) in hole in keeper (45). Insert other end of spring in hole in support block (32).
22. Align holes in formers (13 and 14), keeper (45), and spacer (43). Install bolt (46), three washers (47), and nut (48).

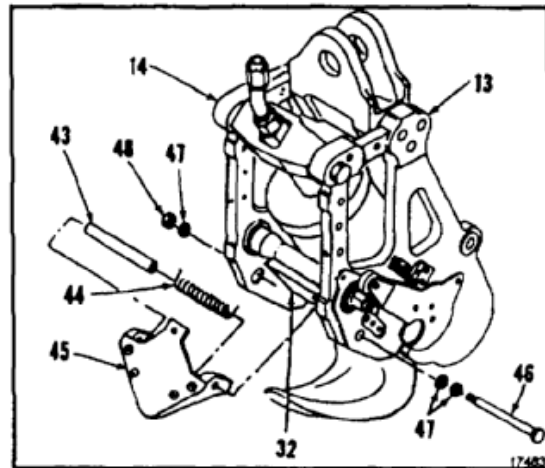

23. Carefully tighten six bolts (31) and nuts (39 and 42), so that formers (13 and 14) pull together squarely. Torque six bolts (31) to **200 inch-pounds**. Lockwire bolts. Use lockwire (E-231).

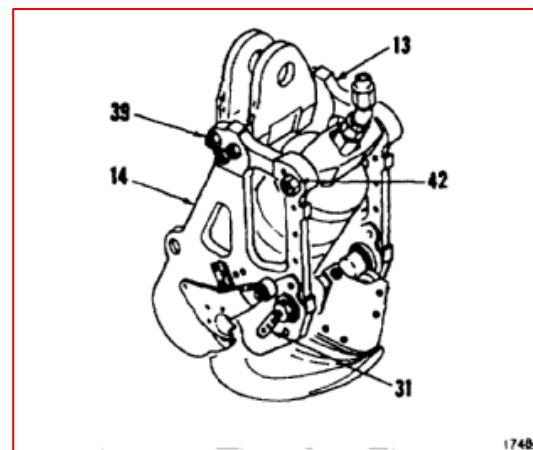

24. Position bushing (49) and synchronizing arm (50) on tube (51) so that bolt holes align. Install bolt (52), washer (53), and nut (54). Torque nut to **30 inch-pounds**.
25. Slide tube (51) through holes in formers (13 and 14).
26. Position bushing (55) and synchronizing arm (56) on tube (51) so that bolt holes align. Install bolt (57), washer (58), and nut (59). Torque nut to **30 inch-pounds**.

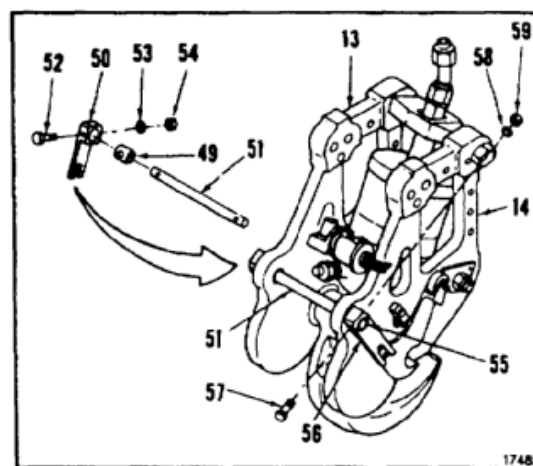

## 16-7.1 ASSEMBLE CENTER CARGO HOOK (AVIM) (Continued)

16-7.1

27. Install two eyebolts (60), washers (61), and nuts (62) in formers (13 and 14).
28. Position cams (63 and 64), rounded surface facing toward synchronizing tube (50), on squared section of shaft (33).
29. Install levers (65 and 66), washers (67), and two nuts (68) on shaft (33).
30. Connect two springs (69) to eyebolts (60) and levers (65 and 66).

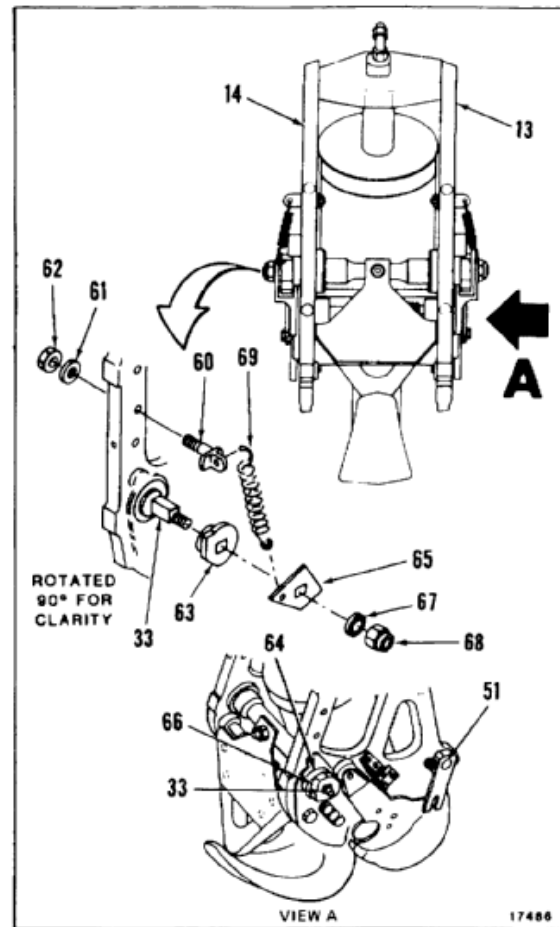

31. Rotate synchronizer arms (50 and 56) over holes in cams (25 and 26). Install two bushings (69) and bolts (70) through forks, in synchronizing arms into cams.
32. Adjust keeper stop (71) as follows:
  - a. Remove lockwire from locknut (72). Loosen locknut.
  - b. Adjust keeper stop (71) so that keeper contacts or is within **0.06 inch** of hook (1).
  - c. Tighten locknut (72). Lockwire locknut. Use lockwire (E231).

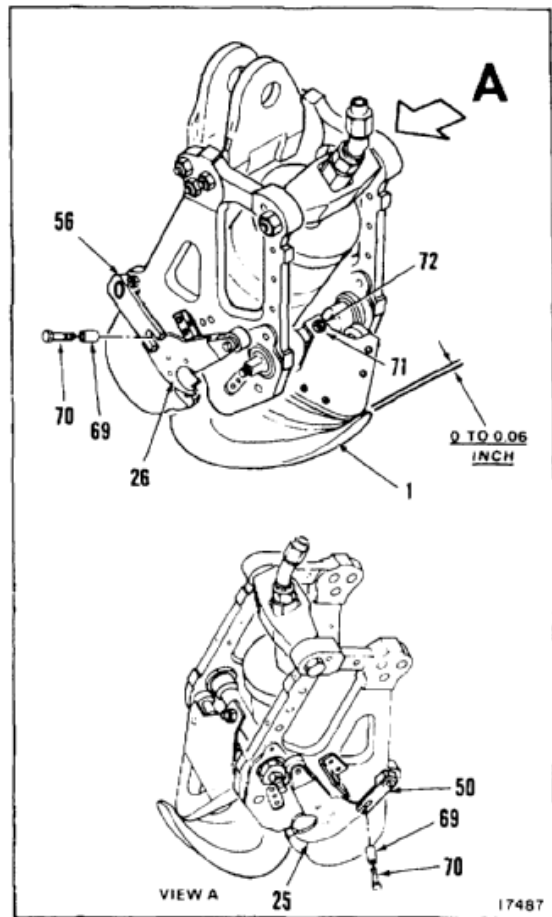

33. Adjust cam stops (21) as follows:
  - a. Lift lever (65) and rotate cams (25 and 26) until they contact stop screws (73).
  - b. Loosen locknuts (74).
  - c. Adjust stop screws (73) until lower edge of cut out in cams (25 and 26) is **0.01 to 0.09 inch** above lower edge of cut out in formers (13 and 14).
  - d. Tighten locknuts (74).

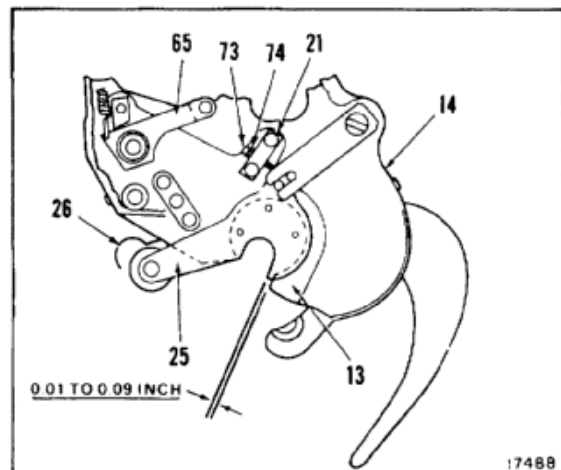



16-7.1 ASSEMBLE CENTER CARGO HOOK (AVIM) (Continued)

16-7.1

- 34. Install switch (75), two washers (76), and nut (77) in bracket (7).
- 35. Install switch (78), two washers (79), and nut (80) in bracket (15).

**NOTE**

Switches are lockwired after adjustment (Task 16-7.2).

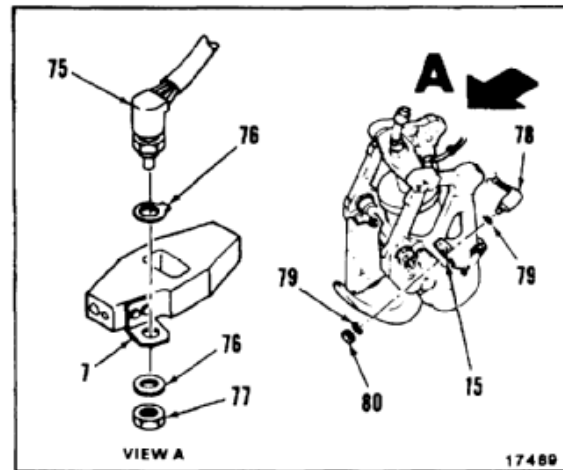

- 36. Position cover (81) on former (14). Install five screws (82), washers (83), plate (84), and strap (85).
- 37. Install screw (86), washer (87), and clamp (88) on cover (81).
- 38. Install hose (89) on actuating cylinder (2).

**NOTE**

Guard will be removed prior to installation. It is temporarily installed to prevent loss of hardware.

- 39. Position two washers (90) under each side of guard (91) between guard and formers (13 and 14). Temporarily install two bolts (92), washers (93), and clamps (94).
- 40. Position two washers (95) between guard (91) and former (14). Temporarily install bolt (96) and washer (97).

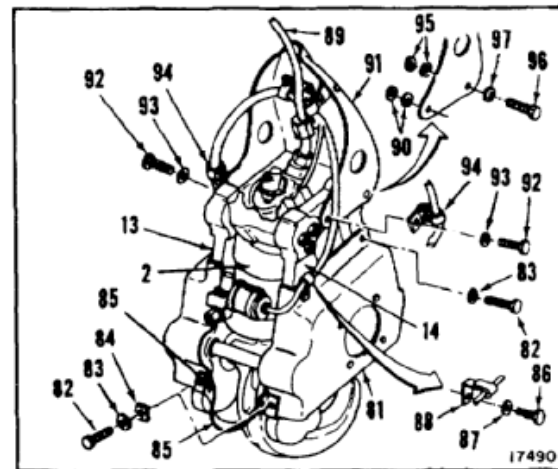

41. Position cover (98) on former (13). Install four screws (99) and washers (100). Install screw (99), washer (100), plate (101), and strap (85).
42. Install bolt (102), washer (103), and bracket (104) with two washers (105) between cover (98) and bracket (104).

**NOTE**

Guard will be removed prior to installation. It is temporarily installed to prevent loss of hardware.

43. Position two washers (106) between guard (91) and former (13). Temporarily install bolt (107) and washer (108) through bracket (104).

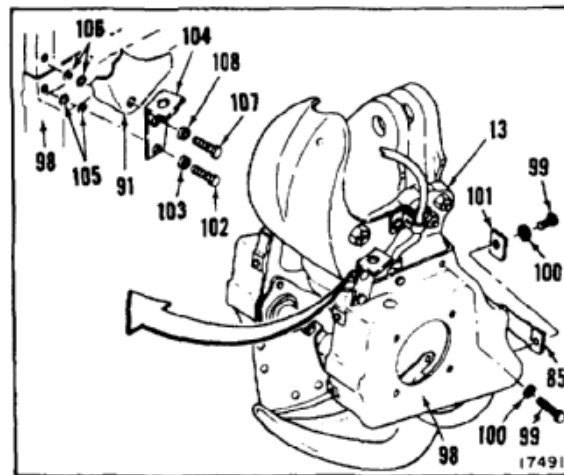

44. Install screw (109), spacer (110), clamp (111), washer (112), and nut (113) on cover (98).
45. Temporarily install two screws (114), bracket (115), clamp (116), washers (117), and nuts (120) on guard (91).
46. Temporarily install screw (121), clamp (122), washer (123), and nut (124) on guard (91).

**INSPECT**

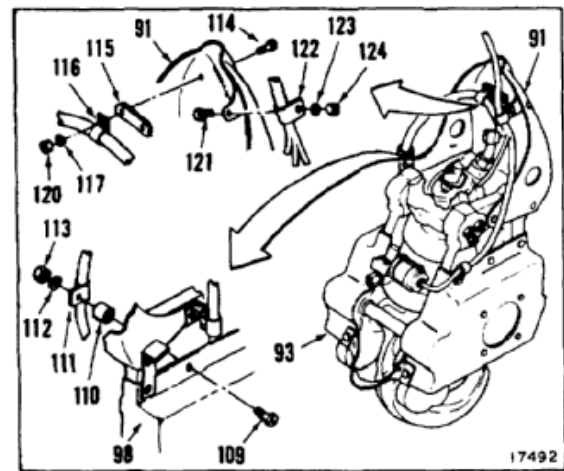

**FOLLOW-ON MAINTENANCE:**

- Test center cargo hook (Task 16-7.1.1).
- Adjust switches (Task 16-7.2).

END OF TASK

16-7.1.1 TEST CENTER CARGO HOOK (AVIM)

16-7.1.1

INITIAL SETUP

**Applicable Configurations:**

All

**Tools:**

- Hydraulic Repairer's Tool Kit, NSN 5180-00-323-4891
- Hydraulic Test Stand
- DC Power Supply, 0 to 50 Volts
- Multimeter
- Stopwatch
- Hoist, 300 Pound Capacity
- Weight, 20 Pound
- Wire Rope Ring (APP E-18)
- Dial Indicating Scale, 0 to 50 Pounds

**Materials:**

None

**Personnel Required:**

- Aircraft Pneudraulics Repairer
- Inspector

**References:**

- Task 16-3 Without **35**
- Task 16-3.1 With **35**
- Task 16-5 Without **35**
- Task 16-5.1 With **35**
- Task 16-7 Without **35**
- Task 16-7.1 With **35**
- Task 16-7.2
- APP E

**Equipment Condition:**

- Off Helicopter Task
- Actuator Serviced to 2,100 psi (Task 1-74)

**General Safety Instructions:**

**WARNING**

Stand clear of hook and load when raising, lowering, or releasing load to prevent injury to personnel.

**WARNING**

Use suitable crash box to shield personnel and equipment in case of failure during test.

**WARNING**

Hydraulic fluid ejected under pressure can cause injury to personnel. Hydraulic fluid sprayed into the air is a fire hazard.

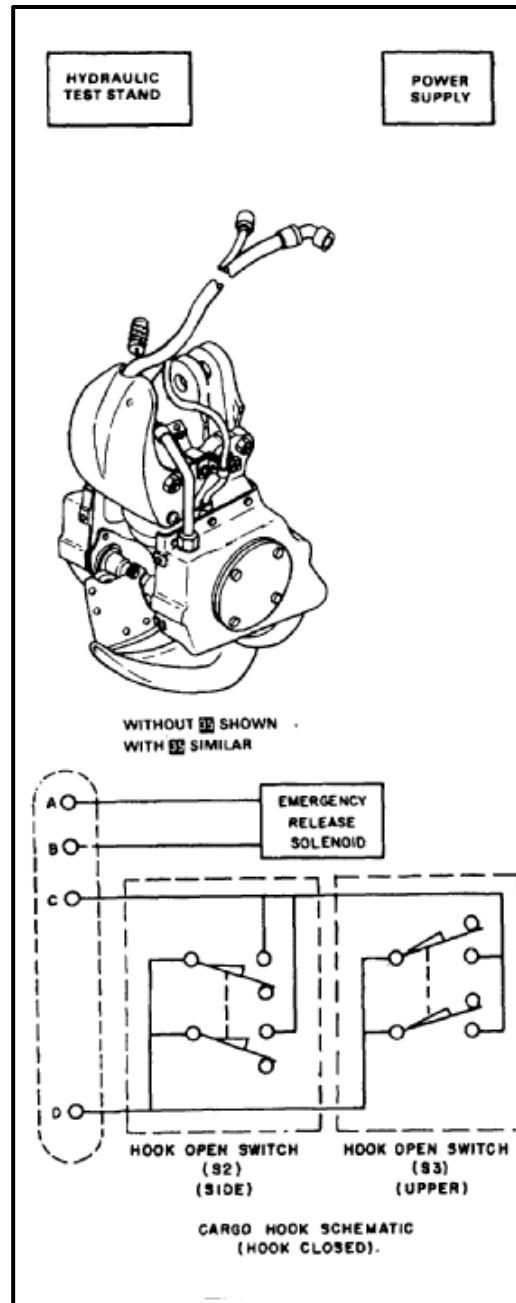

1. Attach hook assembly (1) to hoist (2). Use wire rope ring (3).
2. Raise hoist (2) to lift hook assembly (1) clear of ground.
3. Push down firmly on hook (4) with foot. Hook shall not open.
  - a. If hook opens and cylinder (5) extends, replace cylinder (Tasks 16-5 without **35**, 16-5.1 with **35**).
  - b. If hook opens, but cylinder (5) does not extend, reset and inspect hook mechanism (Tasks 16-3 without **35** and 16-3.1 with **35**).

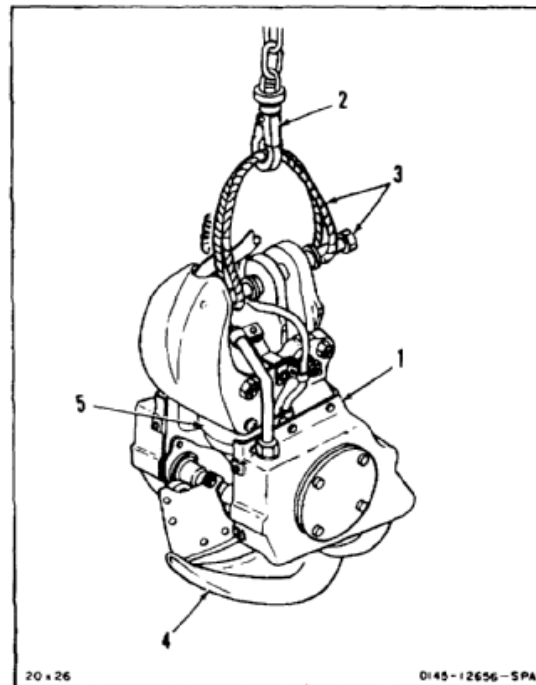

**NORMAL LOAD RELEASE TEST**

4. Attach **20-pound** weight (6) to hook (4). Raise hoist (2) until weight clears ground.
5. Connect hydraulic test stand (7) to hose (8).
6. Connect multimeter (9) to pins C and D of connector (10). Set scale to RX 1.
7. Slowly apply **3,000 psi** hydraulic pressure. Hook (4) shall open and weight (6) shall drop. Multimeter shall indicate **0 ohm**.
  - a. If hook (4) does not open, replace cylinder (5) (Tasks 16-5 and 16-7 without **35**, 16-5.1 and 16-7.1 with **35**).
  - b. If multimeter does not indicate **0 ohm**, adjust switch S3 (11) (Task 16-7.2).
8. Remove hydraulic pressure. Hook (4) shall close. Multimeter (9) shall indicate **infinity**.
  - a. If hook (4) does not close, replace cylinder (5) (Tasks 16-5 and 16-7 without **35**, 16-5.1 and 16-7.1 with **35**).
  - b. If multimeter (9) does not indicate **infinity**, replace switch 83 (11) (Tasks 16-5 and 16-7 without **35**, 16-5.1 and 16-7.1 with **35**).
9. Disconnect hydraulic test stand (7) from hose (8).

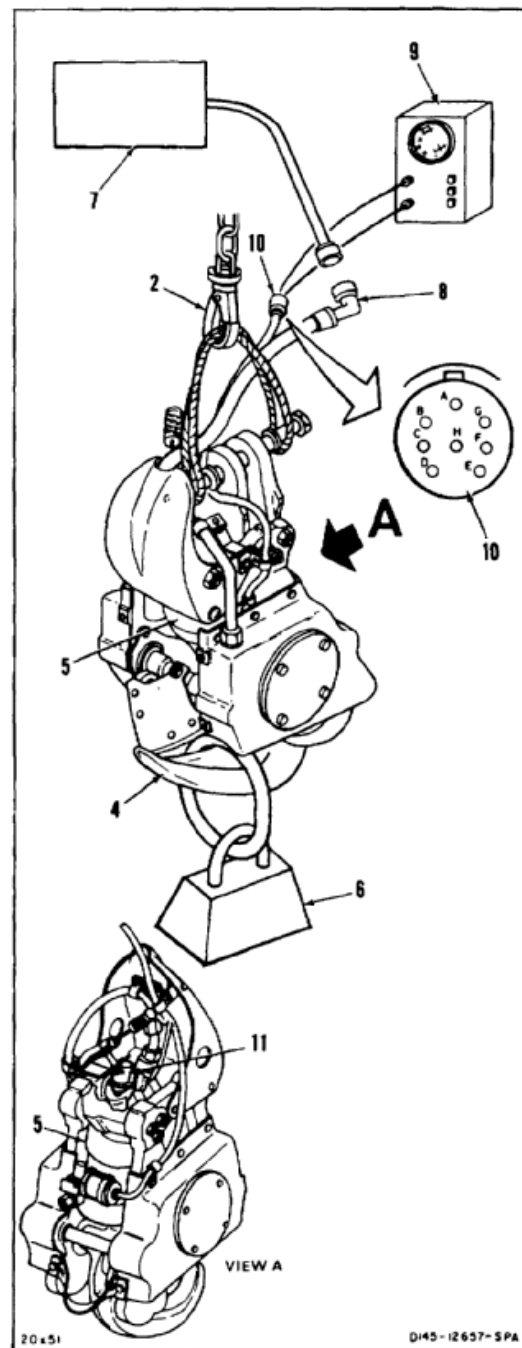

**EMERGENCY LOAD RELEASE TEST (PNEUMATIC)**

10. Check that actuator air pressure gage (12) indicates **2,100 psi**. Service if needed (Task 1-74).
11. Attach weight (6) to hook (4).

**NOTE**

If hook is held open more than several seconds, air charge will deplete. Hook will not close.

12. Momentarily apply **28 vdc** from power supply (13) to pins A and B of connector (10). Hook (4) shall open within **1 second** and weight (6) shall drop. Multimeter shall indicate **0 ohm**.
  - a. If hook (4) does not open within **1 second**, replace cylinder (5) (Tasks 16-5 and 16-7 without **35**, 16-5.1 and 16-7.1 with **35**).
  - b. If multimeter (9) does not indicate **0 ohm**, adjust switch S3 (11) (Task 16-7.2).

**WARNING**

When power is removed from hook, oil mixed with air may be vented from cylinder. Stand away from hook assembly or injury can occur.

13. Remove **28 vdc** from connector (10). Hook (4) shall close. Multimeter (9) shall indicate **infinity**.
  - a. If hook (4) does not close, replace cylinder (5) (Tasks 16-5 and 16-7 without **35**, 16-5.1 and 16-7.1 with **35**).
  - b. If multimeter (9) does not indicate **infinity**, replace switch S3 (11) (Tasks 16-5 and 16-7 without **35**, 16-5, and 16-7.1 with **35**).

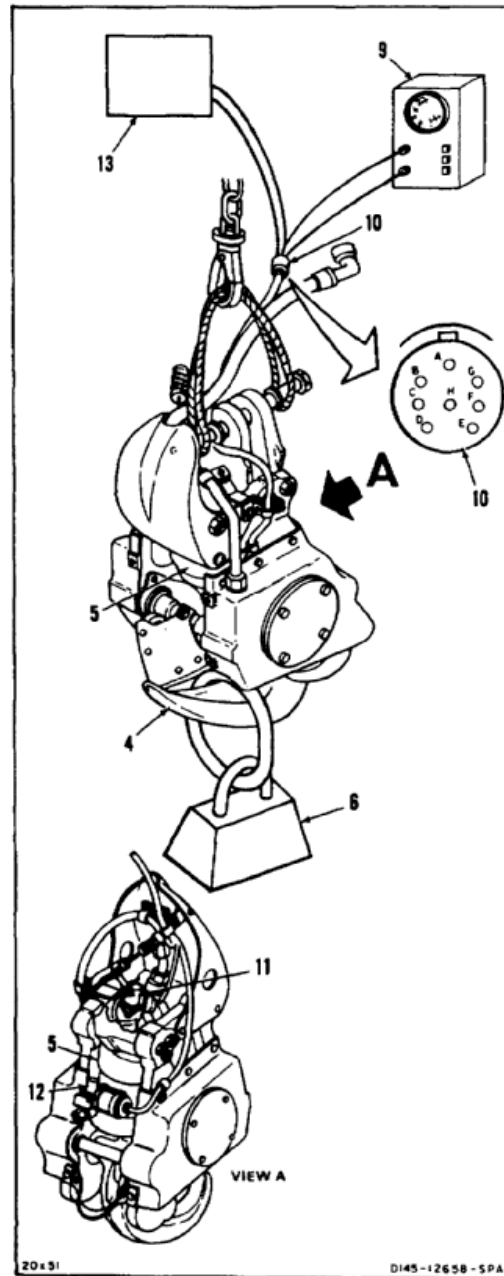

**EMERGENCY LOAD RELEASE TEST (MANUAL)**

14. Attach weight (6) to hook (4).
  15. Pull up on release cable (13). Use a dial indicating scale (14). Hook (4) shall open with **20 pounds** or less pull. Multimeter (9) shall indicate **0 ohm**.
    - a. If hook (4) does not open, or needs more than **20 pounds** pull, inspect release mechanism (Task 16-6). Disassemble as needed (Tasks 16-5 without **35**, 16-5.1 with **35**).
    - b. If multimeter (9) does not indicate **0 ohm**, replace switch S2 (15) (Tasks 16-5 without **35**, 16-5.1 with **35**, 16-7 without **35**, 16-7.1 with **35**).
  16. Manually reset hook (4) (Tasks 16-3 without **35**, 16-3.1 with **35**). Multimeter (9) shall indicate **infinity**. If not, adjust switch S2 (15) (Task 16-7.2).
17. Remove multimeter (9) from connector (10).
  18. Lower hook assembly (1) to ground with hoist (2).
  19. Remove weight (6) from hook (4).
  20. Remove hook assembly (1) and wire rope ring (3) from hoist (2).

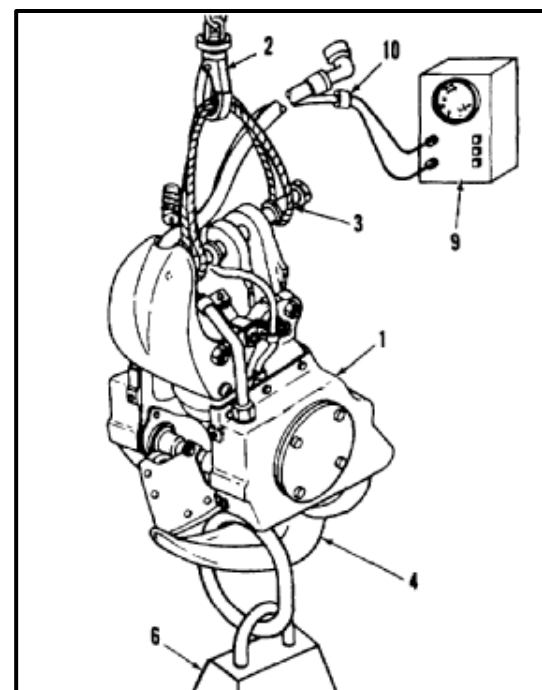
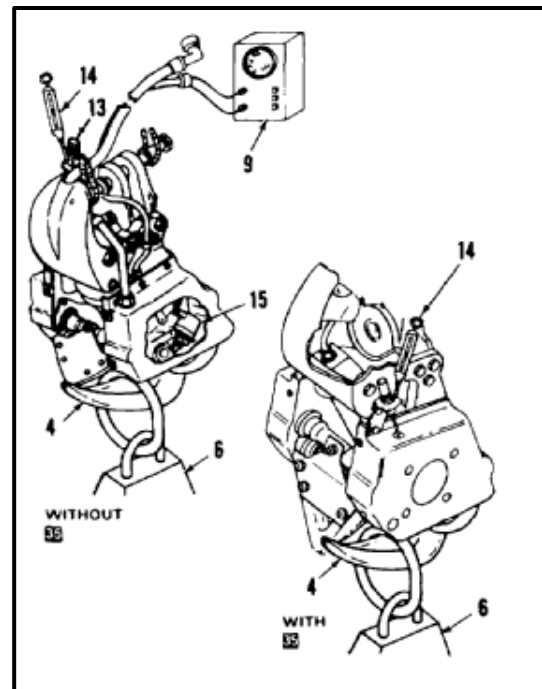
**FOLLOW-ON MAINTENANCE:**

None

END OF TASK

## INITIAL SETUP

**Applicable Configurations:**

All

**Tools:**

Hydraulic Repairer's Tool Kit, NSN 5180-00-323-4891  
 DC Power Supply, 0 to 50 Volts  
 Hoist, 300 Pound Capacity  
 Wire Rope Ring and Bolt Assembly (APP E-18)  
 Multimeter

**Materials:**

Lockwire (E231)

**Personnel Required:**

Aircraft Pneudraulics Repairer  
 Aircraft Electrician  
 Inspector

**References:**

Appendix E  
 Task 16-3 Without **35**  
 Task 16-3.1 With **35**  
 Task 16-5 Without **35**  
 Task 16-5.1 With **35**  
 Task 16-7 Without **35**  
 Task 16-7.1 With **35**  
 APP E

**Equipment Condition:**

Off Helicopter Task  
 Actuator Serviced to 2,100 psi (Task 1-74)

**General Safety Instructions:****WARNING**

Stand clear of hook assembly when raising, lowering, or releasing hook to prevent injury to personnel.

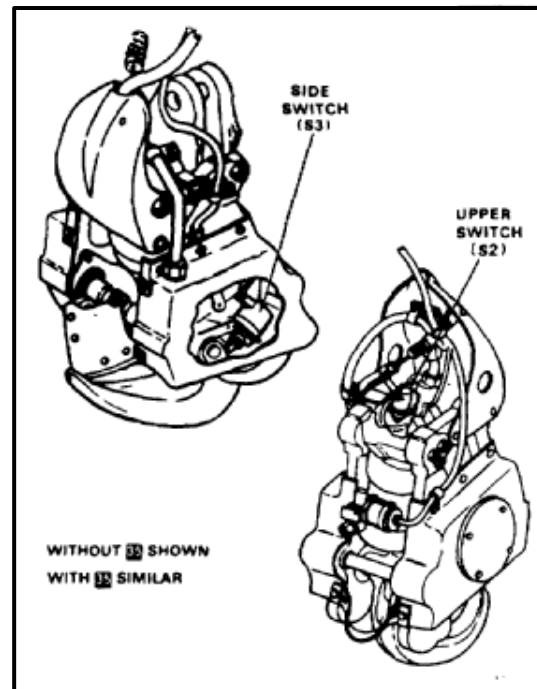



**16-7.2 ADJUST CENTER CARGO HOOK SWITCHES (Continued)**

16-7.2

1. Attach hook assembly (1) to hoist (2). Use wire rope ring and bolt assembly (3).
2. Raise hoist (2) to lift hook assembly (1) clear of ground.
3. Connect multimeter (4) to pins C and D of connector (5).

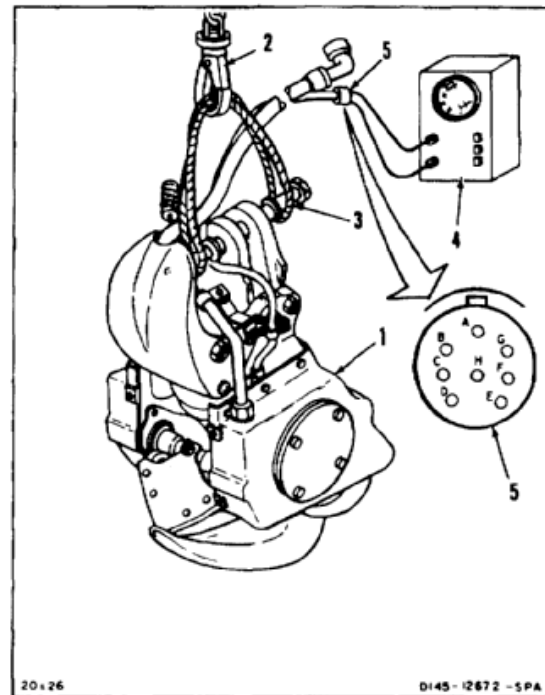
**ADJUST UPPER SWITCH**

4. Connect hydraulic teststand (6) to hose (7). Apply **3,000 psi** pressure to extend actuating cylinder (8).
5. Remove lockwire from locknuts (9 and 10) on switch (12).
6. Turn upper locknut (9) away from bracket (12) as far as possible.
7. Turn lower locknut (10) against bracket (12) until tip of switch (11) is against end of cylinder (8) and multimeter (4) reads **0 ohm**. Continue to turn locknut against bracket **one full turn**.
8. Turn upper locknut (9) down against bracket (12). Lockwire two locknuts (9 and 10). Use lockwire (E231).
9. Remove hydraulic pressure. Check that multimeter (4) reads **infinity**. If it does not, replace switch (11) (Tasks 16-5 and 16-7 without **35**, 16-5.1 and 16-7.1 with **35**).
10. Disconnect hydraulic test stand (6) from hose (7).

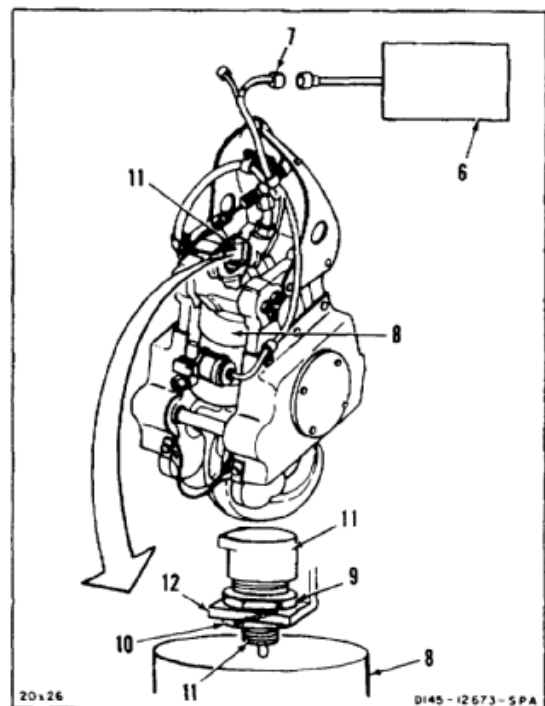

**ADJUST SIDE SWITCH****NOTE**

Before adjusting switch, make sure hook is securely latched (Tasks 16-3 without **35**, 16-3.1 with **35**).

11. Remove four screws (13) and washers (14). Remove access door (15).
12. Remove lockwire from locknuts (16 and 17) on switch (18).
13. Turn upper locknut (16) away from bracket (19) as far as possible.
14. Turn lower locknut (17) against bracket (19) until tip of switch (18) is against cam (20) and multimeter (4) just reads infinity. Continue to turn locknut against bracket **one full turn**. If multimeter cannot be made to read **infinity**, replace switch (Tasks 16-5 and 16-7).
15. Turn locknut (16) down against bracket (19). Lockwire two locknuts (16 and 17). Use lockwire (E231).
16. Install access door (15) with four screws (13) and washers (14).
17. Remove multimeter (4) from connector (5).
18. Lower hook assembly (1) to ground. Remove hook assembly and wire rope ring and bolt assembly (3) from hoist (2).

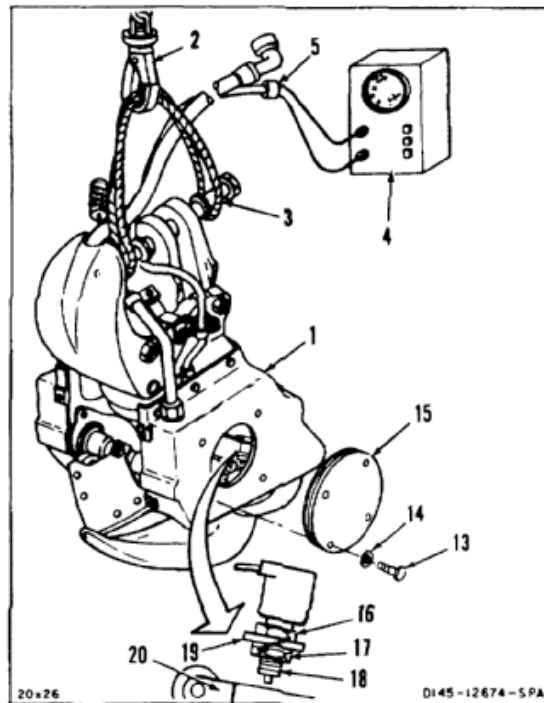
**FOLLOW-ON MAINTENANCE:**

Test center cargo hook (Task 16-7.1.1).

END OF TASK

## INITIAL SETUP

**Applicable Configurations:**Without **35****Tools:**

Aircraft Mechanic's Tool Kit, NSN 5180-00-323-4692  
 Open End Wrench, 1-1/16 Inch  
 Socket, 1-1/16 Inch  
 Container, 2 Quart

**Materials:**

Kevlar Gloves (E187)  
 Carbon Dioxide (Dry Ice) (E92)  
 Methanol (E243)  
 Cloth (E120)

**Parts:**

Cotter Pin

**Personnel Required:**

Medium Helicopter Repairer (2)  
 Inspector

**References:**

Task 1-74  
 TM 55-1520-240-23P

**General Safety Instructions:****WARNING**

Carbon dioxide (dry ice) (E92) causes severe burns (frost bite) and gives off toxic fumes. Use only in well-ventilated area. Do not get in eyes, on skin, or clothing. In case of contact, immediately flush with water. Get medical attention for eyes.

**WARNING**

Methanol (E243) is flammable and toxic. It can irritate skin and cause burns. Use only in well-ventilated area, away from heat and open flame. In case of contact, immediately flush skin or eyes with water for at least **15 minutes**. Get medical attention for eyes.

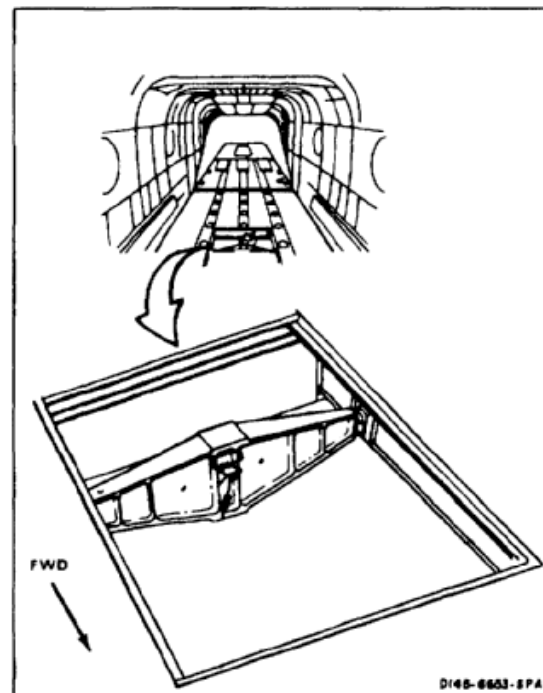

**WARNING**

Dry ice (E92) in methanol (E243) has a temperature of  $-120^{\circ}\text{F}$  ( $-84^{\circ}\text{C}$ ). Observe all safety measures when working with dry ice (E92) and methanol (E243) and when handling chilled parts. Avoid breathing carbon dioxide vapor.

**WARNING**

Wear Kevlar gloves (E187) when handling chilled bearings or heated yoke.

1. Place sleeve spacer (1) in a solution of dry ice (E92) and methanol (E243). Wear goggles and gloves (E187). Allow spacer to chill thoroughly.
2. Have helper support hook (2), open end forward, at support beam (3).
3. Align holes in hook (2) and support beam (3).
4. Remove spacer (1) from solution and wipe clean and dry. Use cloth (E120). Wear goggles and gloves (E187).
5. Install spacer (1) through holes in hook (2) and support beam (3).

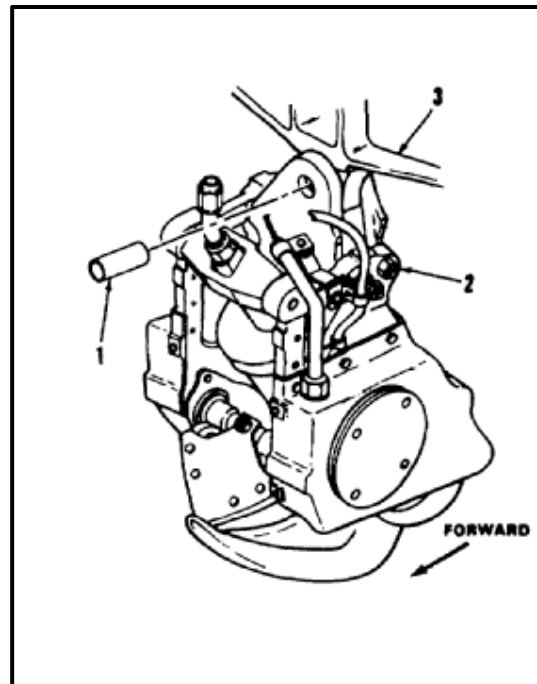

**16-8 INSTALL CENTER CARGO HOOK (Continued)**

16-8

6. Install bolt (4), head forward, two washers (5), and nut (6) in sleeve spacer (1).
7. Install cotter pin (7).

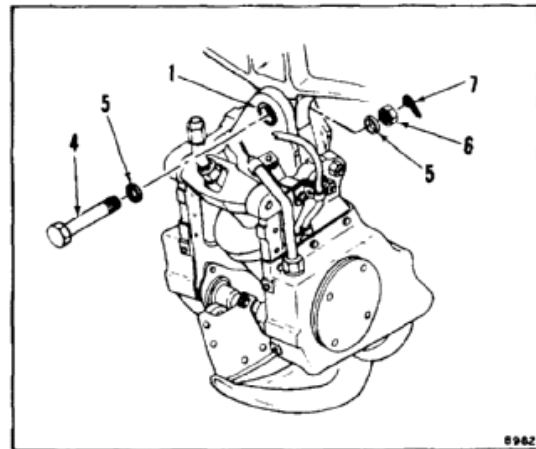

8. Spread guard (8) enough to fit over bolt (9) and nut (10). Install guard.

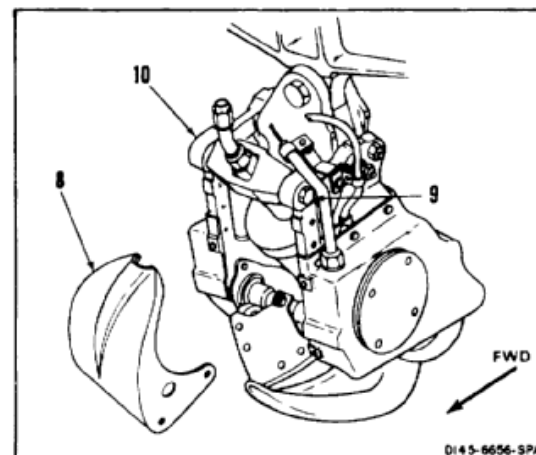

9. Position two washers (11) between guard (8) and hook (2). Install bolt (12), washer (13), and clamp (14).
10. Position bracket (15) between guard (8) and hook (2). Install bolt (16), washer (17), and clamp (18).
11. Position two washers (19), two on each side of hook (2), between guard (8) and hook. Install two bolts (20) and washers (21).

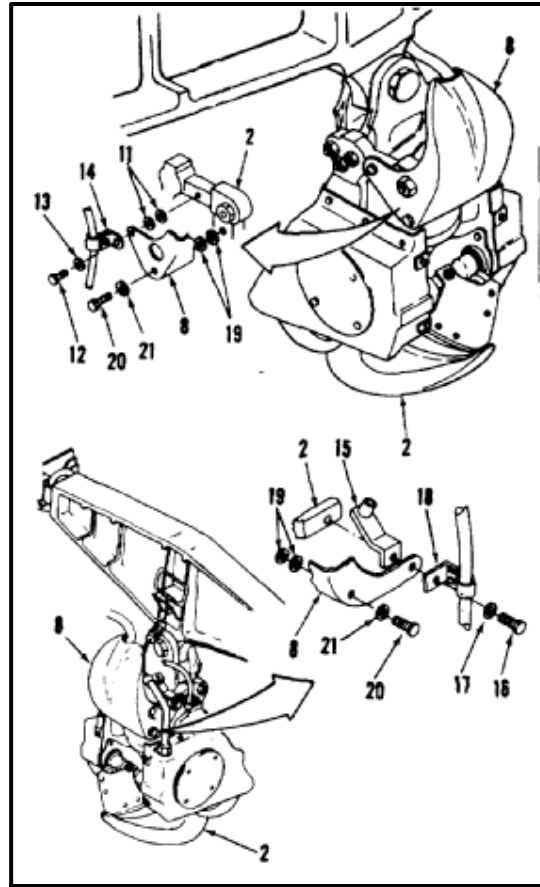

12. Connect manual release cable (22) at cable lock (23).
13. Connect electrical cable (24) at connector (25).
14. Connect hose (26) at quick-disconnect (27).
15. Position clamp (28) with bungee cord (29) on hose (26) and electrical cable (24). Install screw (30), washer (31), and nut (32) in clamp.

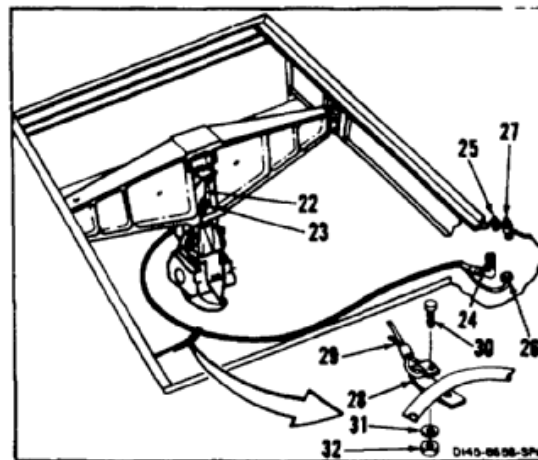

**16-8 INSTALL CENTER CARGO HOOK (Continued)****16-8**

16. Service cargo hook actuating cylinder (32) (Task 1-74).
17. Have helper lift cargo hook (2) to stowed position. Slide stowage strap (33) through hook (34) and tighten strap.

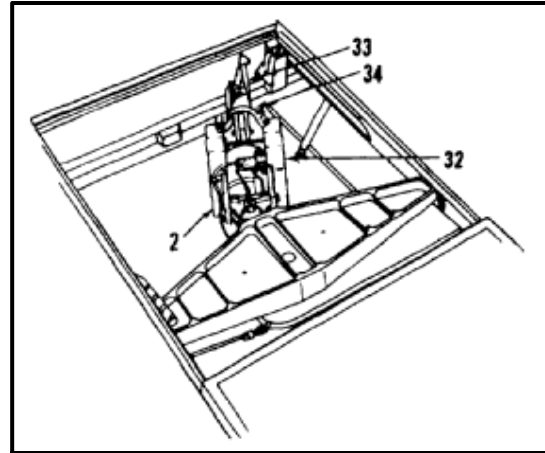
**INSPECT****FOLLOW-ON MAINTENANCE:**

- Close rescue hatch (Task 2-2).
- Perform operational check of cargo hook (TM 55-1520-240-T).

END OF TASK

## INITIAL SETUP

**Applicable Configurations:**

With **35**

**Tools:**

Aircraft Mechanic's Tool Kit, NSN 5180-00-323-4692  
 Open End Wrench, 1-1/16 Inch  
 Socket, 1-1/16 Inch  
 Container, 2 Quart

**Materials:**

Kevlar Gloves (E187)  
 Carbon Dioxide (Dry Ice) (E92)  
 Methanol (E243)  
 Cloth (E120)

**Parts:**

Cotter Pin

**Personnel Required:**

Medium Helicopter Repairer (2)  
 Inspector

**References:**

Task 1-74  
 TM 55-1520-240-23P

**General Safety Instructions:****WARNING**

Carbon dioxide (dry ice) (E92) causes severe burns (frost bite) and gives off toxic fumes. Use only in well-ventilated area. Do not get in eyes, on skin, or clothing. In case of contact, immediately flush with water. Get medical attention for eyes.

**WARNING**

Methanol (E243) is flammable and toxic. It can irritate skin and cause burns. Use only in well-ventilated area, away from heat and open flame. In case of contact, immediately flush skin or eyes with water for at least **15 minutes**. Get medical attention for eyes.

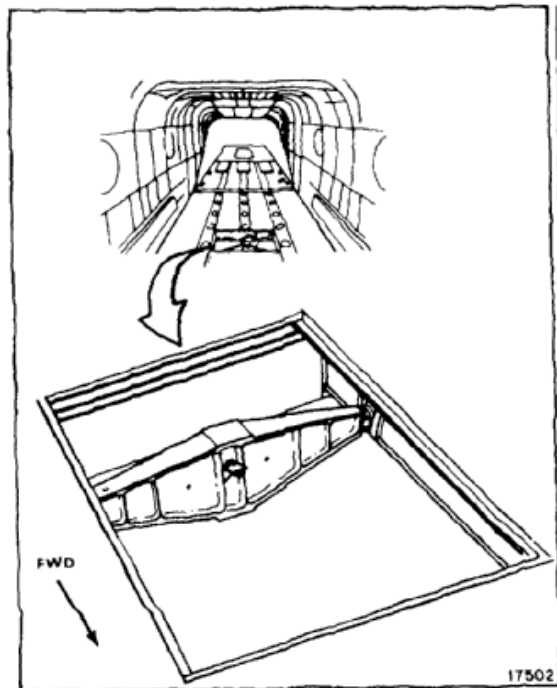



**WARNING**

Dry ice (E92) in methanol (E243) has a temperature of  $-120^{\circ}\text{F}$   $-84.4^{\circ}\text{C}$ . Observe all safety measures working with dry ice (E92) and methanol (E243) and when handling chilled parts. Avoid breathing carbon dioxide vapor.

**WARNING**

Wear Kevlar gloves (E187) when handling chilled bearings or heated yoke.

**NOTE**

Guard was temporarily installed to prevent loss of hardware.

1. Remove two bolts (1), washers (2), and clamps (3) from guard (4). Remove four washers (5) from behind guard.
2. Remove two bolts (6) and washers (7) from guard (4). Remove four washers (8) from behind guard. Remove guard.
3. Place sleeve spacer (9) in a solution of dry ice (E92) and methanol (E243). Wear goggles and Kevlar gloves (E187). Allow spacer to chill thoroughly.
4. Have helper support hook (10), open end forward, at support beam (11).
5. Align holes in hook (10) and support beam (11).
6. Remove spacer (9) from solution and wipe clean and dry. Use cloth (E120). Wear goggles and Kevlar gloves (E187).
7. Install spacer (9) through holes in hook (10) and support beam (11).

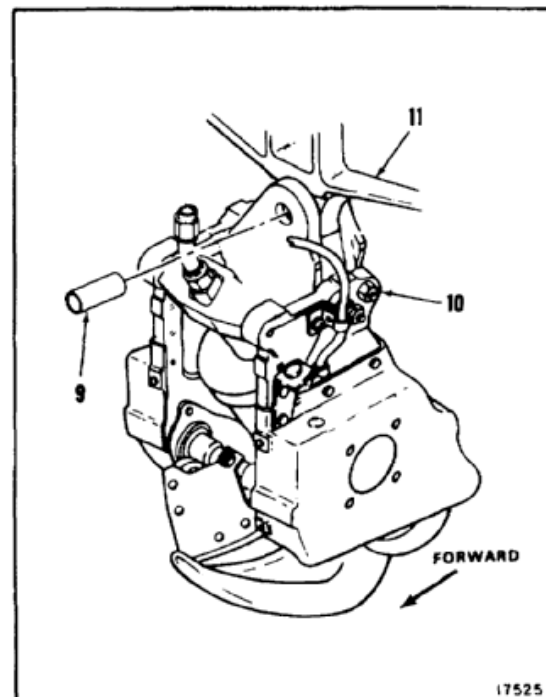
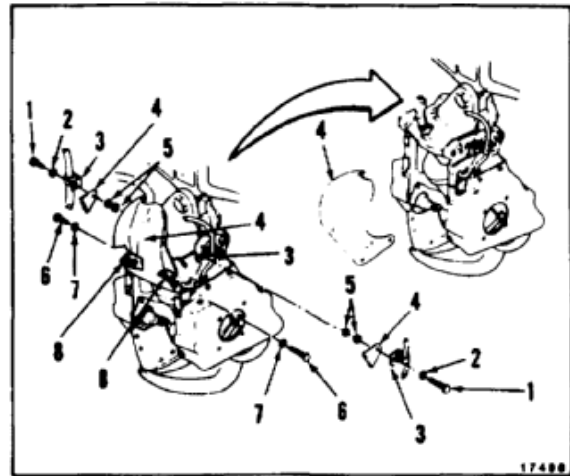

8. Install bolt (12), head forward, two washers (13), and nut (14) in sleeve of spacer (9).
9. Torque nut to a minimum **950 to 1100 inch-pounds** maximum (for cotter pin alignment). Install cotter pin (15).

**NOTE**

Center pivot bolt assembly may be rotated by hand pressure only.

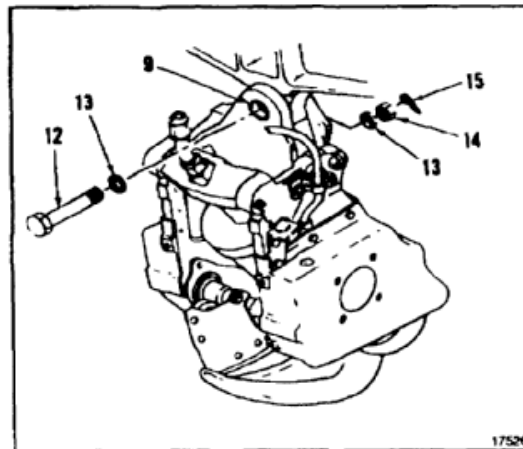

10. Spread guard (4) enough to fit over bolt (16) and nut (17). Install guard.

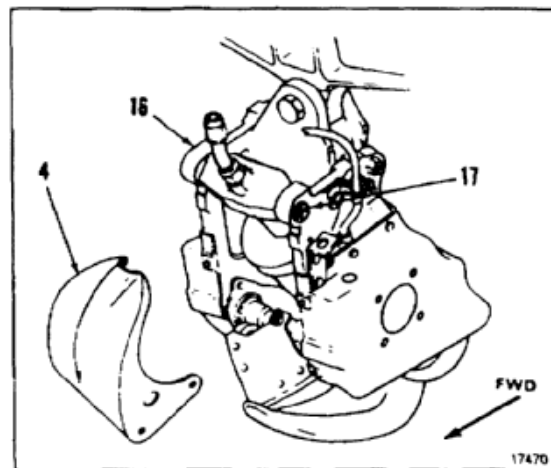

**16-8.1 INSTALL CENTER CARGO HOOK (Continued)**

16-8.1

11. Position four washers (8) between guard (4) and hook (10). Install two bolts (6) and washers (7).
12. Position four washers (5) between guard (4) and hook (10). Install two bolts (1), washers (2), and clamps (3).

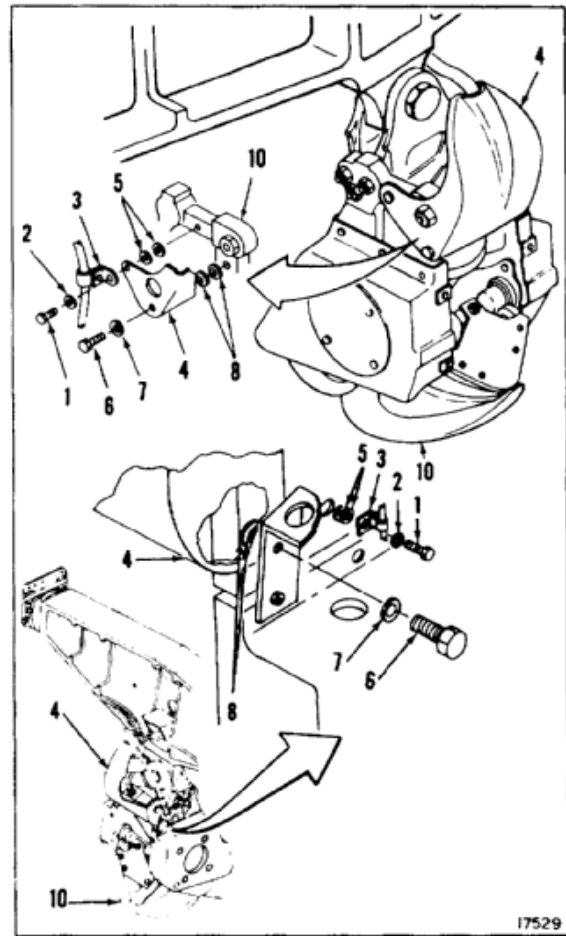

13. Connect manual release cable (18) at bracket (19) (Task 16-3.4).
14. Connect electrical cable (20) at connector (21).
15. Connect hose (22) at quick-disconnect (23).
16. Position clamp (24) with bungee cord (25) on hose (22) and electrical cable (20). Install screw (26), washer (27), and nut (28) in clamp.

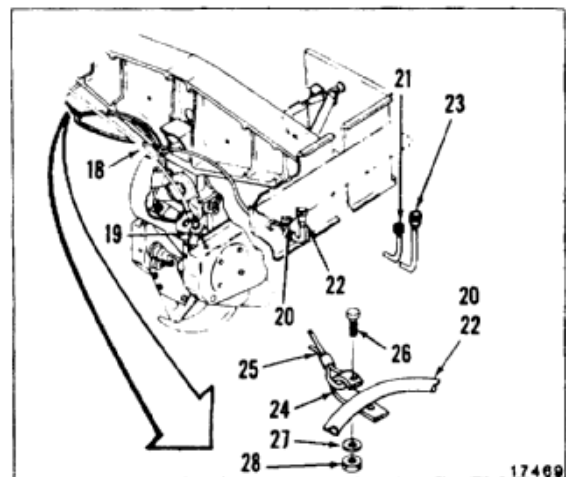

17. Service cargo hook actuating cylinder (29) (Task 1-74).
18. Have helper lift cargo hook (10) to stowed position. Slide stowage strap (30) through hook (31) and tighten strap.

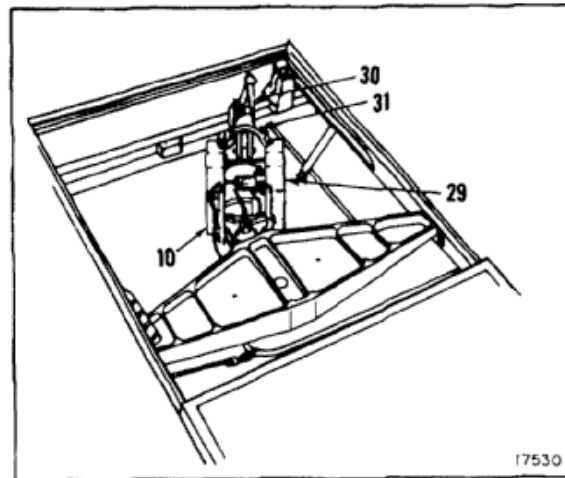
**INSPECT****FOLLOW-ON MAINTENANCE:**

- Close rescue hatch (Task 2-2).
- Perform operational check of cargo hook (TM 55-1520-240-T).

END OF TASK

**16-8.1.1 INSPECT SUPPORT BEAM BUSHINGS**

16-8.1.1

**INITIAL SETUP****Applicable Configurations:**

All

**Tools:**

Telescoping Gage, NSN 5120-00-221-2086  
 Outside Micrometer Caliper Set GGG-C-105

**Materials:**

Cloths (E120)

**Personnel Required:**

Medium Helicopter Repairer  
 Inspector

**References:**

Task 16-8.2  
 Task 16-8.3

**Equipment Condition:**

Battery Disconnected (Task 1-39)  
 Electrical Power Off  
 Center Cargo Hook Removed (Tasks 16-4 With **35**,  
 16-4.1 Without **35**)

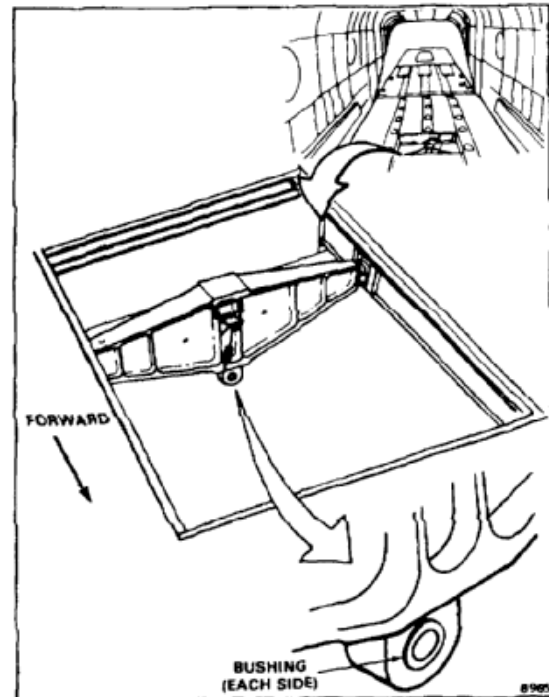

1. Clean bushing hole (1). Use cloths (E120).
2. Measure diameter of hole (1) of bushing (2) on each side of beam (3) at several points. If any diameter is greater than **1.007 inches**, replace bushing (Tasks 16-8.2 and 16-8.3).

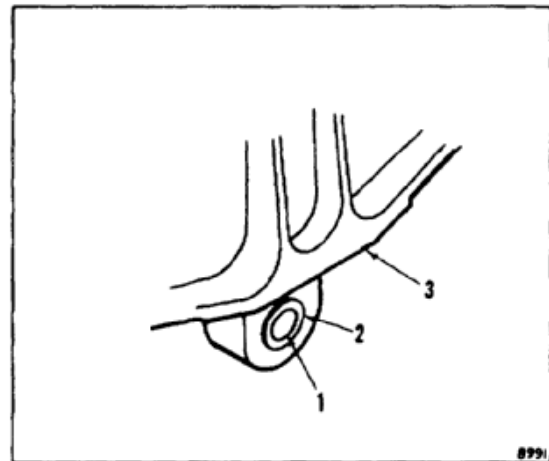
**FOLLOW-ON MAINTENANCE:**

None

END OF TASK

## INITIAL SETUP

**Applicable Configurations:**

All

**Tools:**

Blind Hole Puller Set, NSN 5120-01-008-7974

**Materials:**

None

**Personnel Required:**

Medium Helicopter Repairer

**Equipment Condition:**

Battery Disconnected (Task 1-39)

Electrical Power Off

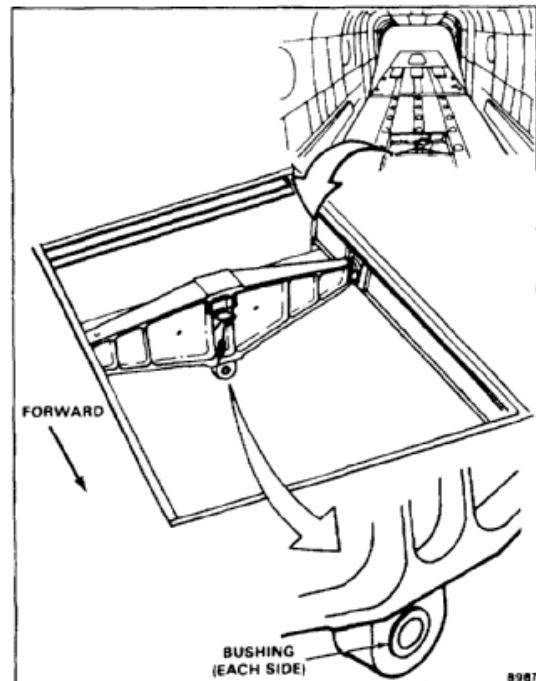
Center Cargo Hook Removed (Tasks 16-4 Without **35** and 16-4.1 With **35**)

1. Install a **1 inch** collet (1) through bushing (2) to be removed.
2. Thread actuator pin (3) into collet (1). Turn pin to expand flange of collet behind bushing (2).



Do not hit beam with slide hammer assembly. Beam can be damaged.

3. Screw slide hammer assembly (4) into pin (3). Use hammer to pull bushing (2) from beam (5).
4. Repeat steps 1 thru 3 for remaining bushing (6).

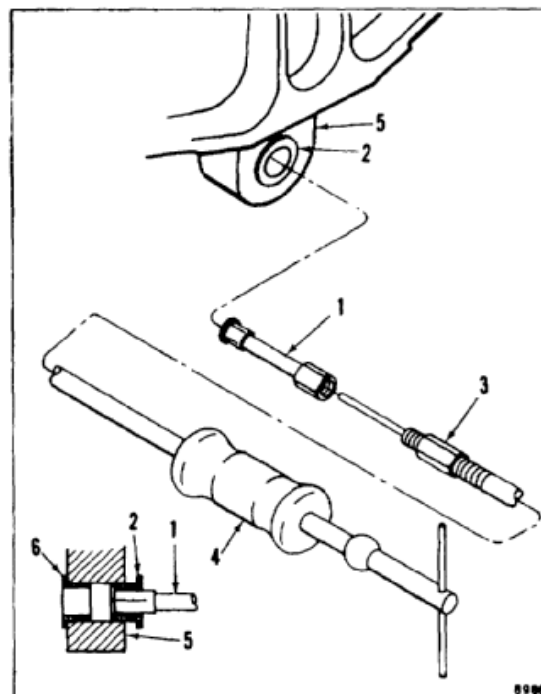
**FOLLOW-ON MAINTENANCE:**

None

END OF TASK

**16-8.3 INSTALL SUPPORT BEAM BUSHINGS**

16-8.3

**INITIAL SETUP****Applicable Configurations:**

All

**Tools:**

Aircraft Mechanic's Tool Kit, NSN 51 80-00-323-4692  
Wood, Teflon, or Phenolic Block

**Materials:**

Dry Cleaning Solvent (E162)  
Cloths (E120)  
Carbon Dioxide (Dry Ice) (E92)  
Methanol (E243)  
Epoxy Primer (E292)  
Gloves (E184.1)  
Kevlar Gloves (E187)

**Personnel Required:**

Medium Helicopter Repairer  
Inspector

**References:**

TM 55-1520-240-23P

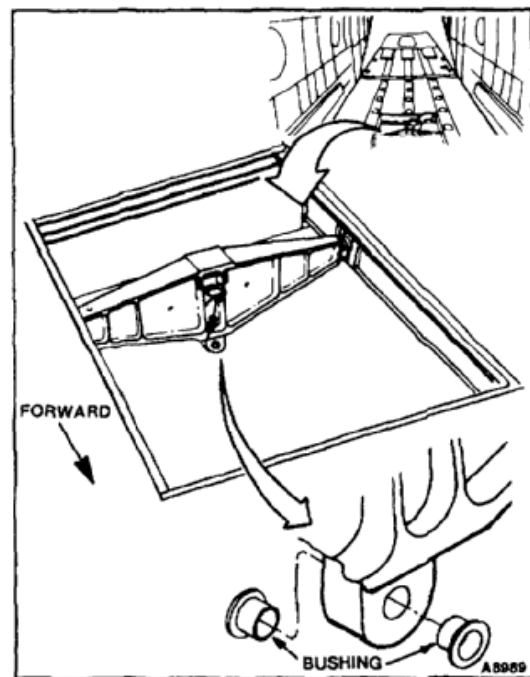
**General Safety Instructions:****WARNING**

Carbon dioxide (dry ice) (E92) causes severe burns (frost bite) and gives off toxic fumes. Use only in well-ventilated area. Do not get in eyes, on skin, or clothing. In case of contact, immediately flush skin or eyes with water for at least **15 minutes**. Get medical attention for eyes.

**WARNING**

Methanol (E243) is flammable and toxic. It can irritate skin and cause burns. Use only in well-ventilated area, away from heat and open flame. In case of contact, immediately flush skin or eyes with water for at least **15 minutes**. Get medical attention for eyes.

**WARNING**

Dry ice (E92) in methanol (E243) has a temperature of  $-120^{\circ}\text{F}$  ( $-84.4^{\circ}\text{C}$ ). Observe all safety measures when working with dry ice (E92) and methanol (E243), and when handling chilled parts. Avoid breathing carbon dioxide vapor.

**WARNING**

Wear Kevlar gloves (E187) when handling chilled bushings.

- Place two bushings (1) in a mixture of dry ice (E92) and methanol (E243). Wear Kevlar gloves (E187) and goggles. Allow bushings to cool.

**WARNING**

Dry cleaning solvent (E162) is flammable and toxic. It can irritate skin and cause burns. Use only in well-ventilated area, away from heat and open flame. In case of contact, immediately flush skin or eyes with water for at least **15 minutes**. Get medical attention for eyes.

- Clean inside of bore (2). Use solvent (E162) and clean cloths (E120). Wear gloves (E184.1).

**WARNING**

Epoxy primer (E292) is flammable and toxic. It can irritate skin and cause burns. Use only with adequate ventilation, away from heat or open flame. Avoid contact with skin, eyes, or clothing. In case of contact, immediately flush skin or eyes with water for at least **15 minutes**. Get medical attention for eyes.

**NOTE**

Bushings must be installed while primer is wet.

- Coat inside of bore (2) with epoxy primer (E292). Wear gloves (E184.1).

**NOTE**

Work quickly with chilled bushing. Bushing must be installed before it warms.

- Remove one bushing (1) from dry ice mixture. Wear Kevlar gloves (E187) and goggles.

**CAUTION**

Bushing is Teflon coated. Careless handling can damage Teflon.

- While primer is still wet, press bushing (1) into bore (2). Use a wood, phenolic, or aluminum block.

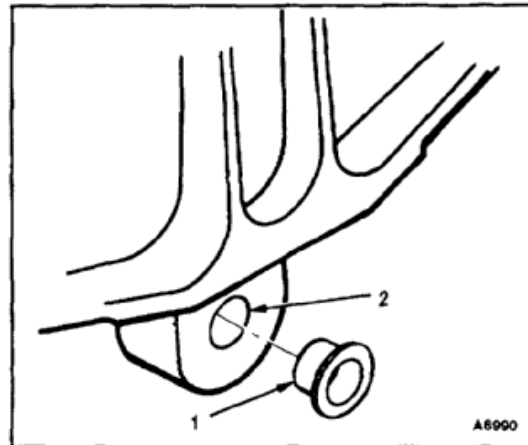



**16-8.3 INSTALL SUPPORT BEAM BUSHINGS (Continued)**

16-8.3

6. Wipe excess primer from around installed bushing (1). Use clean cloths (E120).
7. Repeat steps 4 thru 6 for second bushing (1).

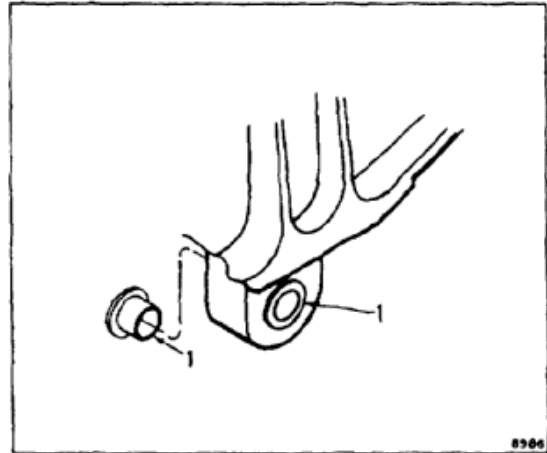
***FOLLOW-ON MAINTENANCE:***

Install center cargo hook (Tasks 16-8 without **35** and 16-8.1 with **35**).

END OF TASK

INITIAL SETUP

**Applicable Configurations:**

All

**Tools:**

Aircraft Mechanic's Tool Kit, NSN 5180-00-323-4692

**Materials:**

None

**Personnel Required:**

Medium Helicopter Repairer

**Equipment Condition:**

Battery Disconnected (Task 1-39)

Electrical Power Off

Center Cargo Hook Removed (Tasks 16-4 Without **35** and 16-4.1 With **35**)

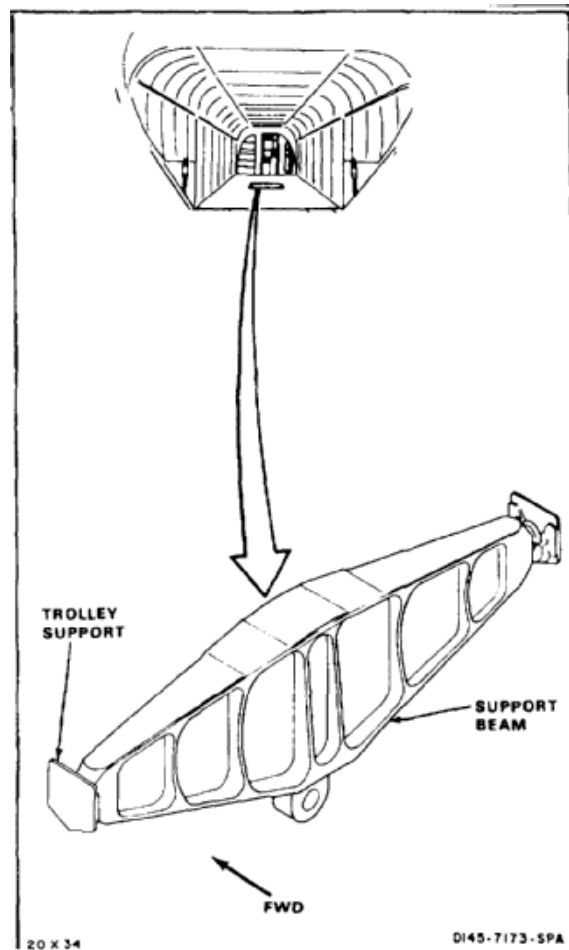

1. Remove nut (1), screw (2), washer (3), and jumper (4) from beam (5).
2. Remove two nuts (6), two washers (7), and u-bolts (8) from each trolley support (9).

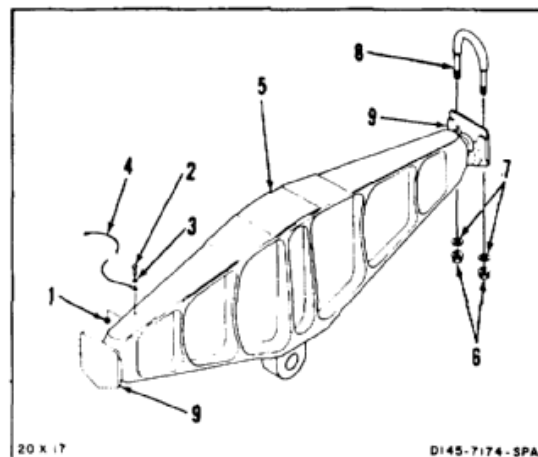

**16-9 REMOVE SUPPORT BEAM AND BEARINGS (Continued)**

16-9

3. Lift beam (5) up and remove it from trolley supports (9).
4. Remove two bearings (10) from beam (5).

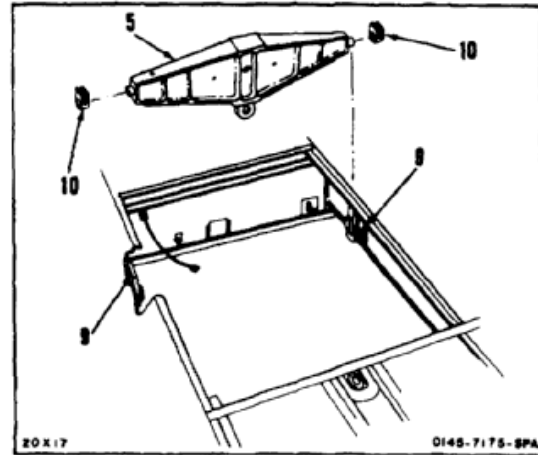
***FOLLOW-ON MAINTENANCE:***

None

END OF TASK

## INITIAL SETUP

**Applicable Configurations:**

All

**Tools:**

Aircraft Mechanic's Tool Kit, NSN 5180-00-323-4692

**Materials:**

None

**Personnel Required:**

Medium Helicopter Repairer

**Equipment Condition:**

Off Helicopter Task

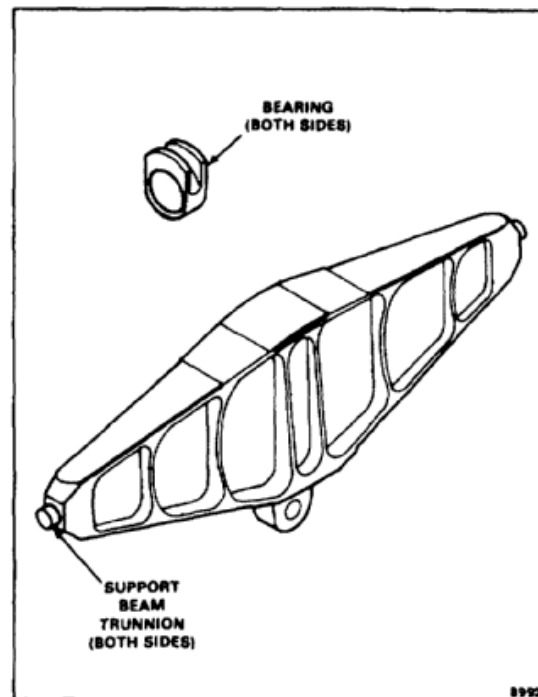

1. Measure diameter of trunnion (1) on each side of beam (2). Diameter shall not be less than **1.37 inches**.
2. Check Teflon liner (3) in each bearing (4) for wear. If liner is frayed or worn enough to expose metal, reject bearing.

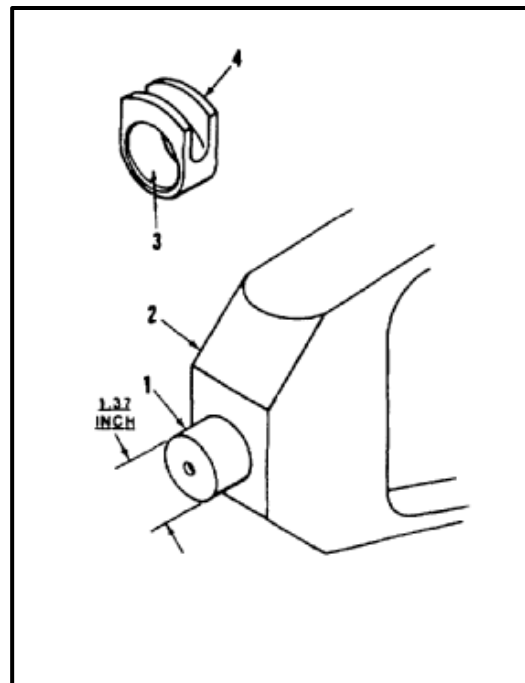
**FOLLOW-ON MAINTENANCE:**

None

END OF TASK

INITIAL SETUP

**Applicable Configurations:**

All

**Tools:**

Aircraft Mechanic's Tool Kit, NSN 51 80-00-323-4692  
Torque Wrench, 100 to 750 Inch-Pounds

**Materials:**

Cloths (E135)  
Gloves (E184.1)  
Methy-Ethyl-Ketone (E244)  
Epoxy Primer (E292.1)

**Personnel Required:**

Medium Helicopter Repairer  
Inspector

**References:**

TM 55-1520-240-23P

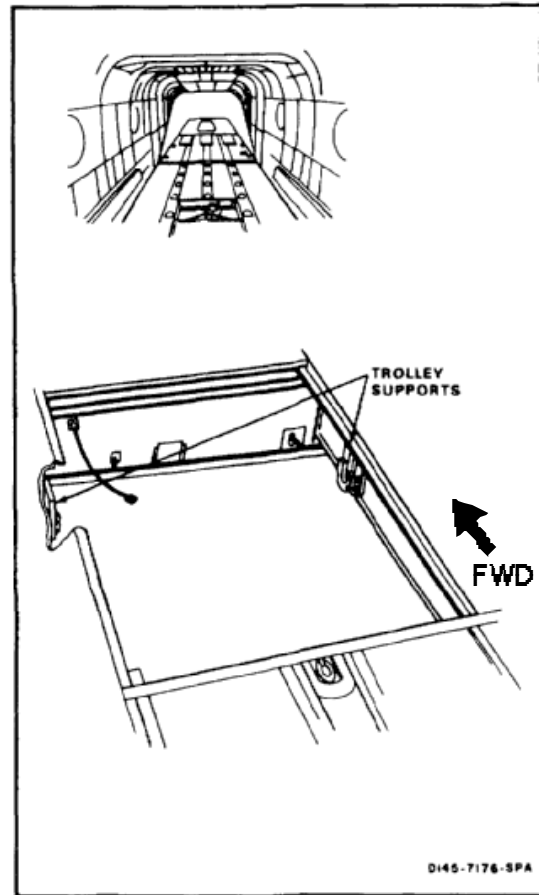

1. Install bearing (1), groove facing up, on each end of support beam (2).
2. Install beam (2), support (3), facing forward, in trolley supports (4).
3. Install two u-bolts (5), four washers (6), and four nuts (7). Torque nuts to **180 to 240 inch-pounds**.

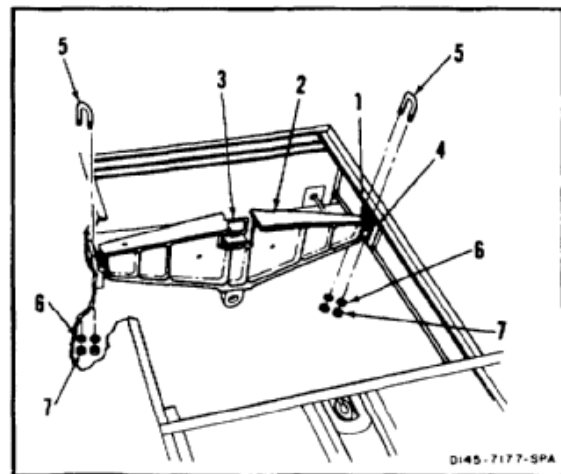

**WARNING**

Methyl-ethyl-ketone (E244) is flammable and toxic. It can irritate skin and cause burns. Use only in well-ventilated area, away from heat and open flame. In case of contact, immediately flush skin or eyes with water for at least **15 minutes**. Get medical attention for eyes.

4. If installed, clean jumper (8) and bonding point on beam (2). Use cloths (E135) and methyl-ethyl-ketone (E244). Wear gloves (E184.1).
5. Install screw (9), washer (10), jumper (8), and nut (11) on beam (2).

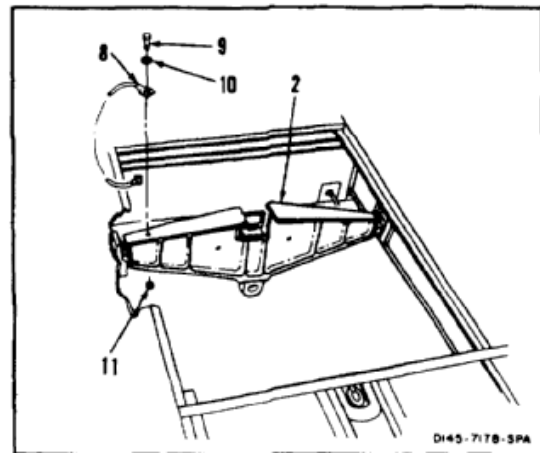
**WARNING**

Epoxy primer (E292.1) is flammable and toxic. It can irritate skin and cause burns. Use only with adequate ventilation, away from heat or open flame. Avoid contact with skin, eyes, or clothing. In case of contact, immediately flush skin or eyes with water for at least **15 minutes**. Get medical attention for eyes.

6. Apply epoxy primer (E292.1) to bonded area.

**INSPECT****FOLLOW-ON MAINTENANCE:**

None

END OF TASK

INITIAL SETUP

**Applicable Configurations:**

All

**Tools:**

Aircraft Mechanic's Tool Kit, NSN 5180-00-323-4692  
Torque Wrench, 30-150 Inch-Pounds

**Materials:**

Corrosion-Preventive Compound (E154.1)  
Abrasive Pads (E2)  
Lockwire (E231)

**Personnel Required:**

CH-47 Helicopter Repairer  
Inspector

**References:**

Task 16-35.1

**Equipment Condition:**

Battery Disconnected (Task 1-39)  
Electrical Power Off  
Hydraulic Power Off

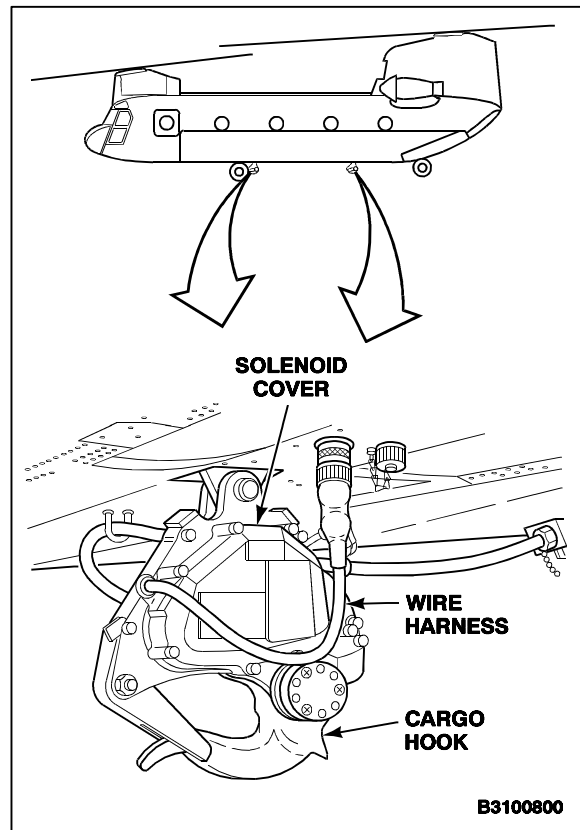

**NOTE**

Procedure is same to inspect forward or aft hook.

1. Check electrical plug (1) for security.

**NOTE**

Electrical cable (2) may exit cargo hook cover at either the **3 o'clock** or the **12 o'clock** position.

2. Inspect electrical cable (2). There shall be no kinking, chafing, or deterioration.

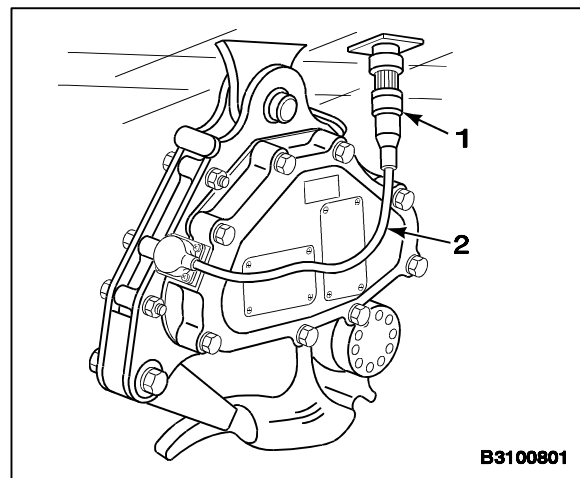

- 3. Check mechanical release cable (3) for security.
- 4. Check mechanical release cable in feed-thru-fitting (4) for security.

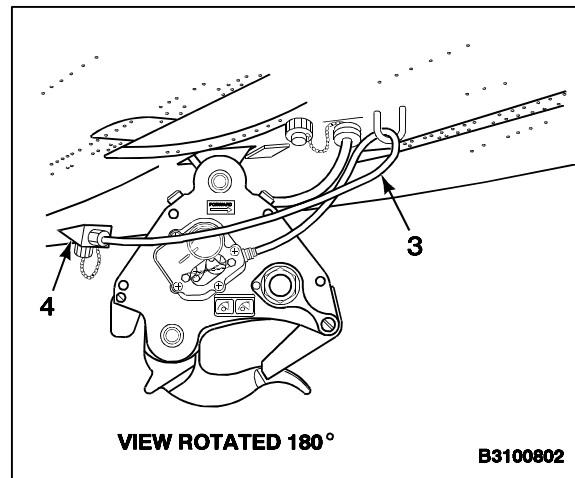

- 4.1. Check that trunnion bumpers (4.1) and side bumpers (4.2) are present and in good condition.
- 5. Swing hook (5) forward and aft and check that hook pivots freely on fitting (6).
- 6. Swing hook (5) side to side and check that hook pivots freely on bolt (7).

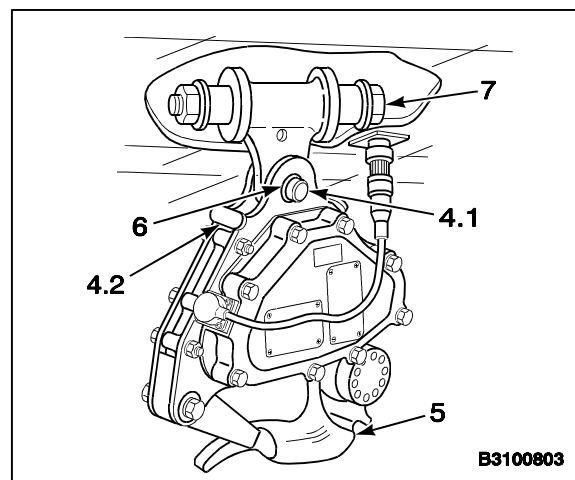

- 6.1. Push up on load beam (7.1) to take weight off roller (7.2). Check that roller rotates freely.
- 6.2. If roller (7.2) does not rotate freely, lubricate it. Use corrosion-preventive compound (E154.1). Clean outside surface of roller. Use abrasive pad (E2).
- 6.3. Check load beam (7.1) for corrosion. Remove corrosion with abrasive pad (E2).

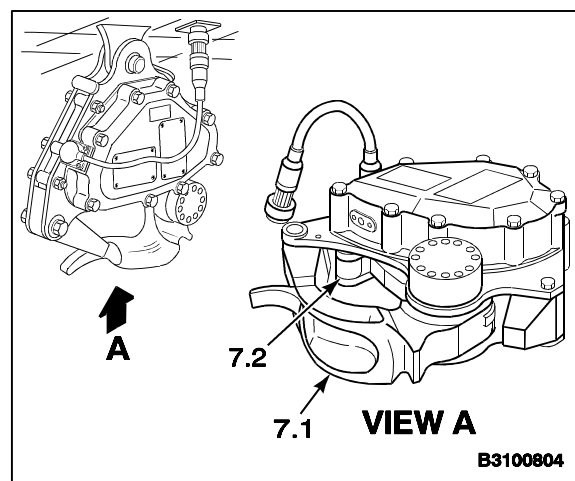



**16-11 INSPECT FORWARD AND AFT CARGO HOOKS (Continued)**

16-11

7. Check thru inspection window (8) that hook linkage is locked. Refer to decal (9) on side of hook (5).
8. Remove lockwire and loosen two bolts (10).
9. Swing window (8) down to clear release arm (11).
10. Check clearance between ball end (12) and surface 'X' of arm (11). Clearance shall be **0.00 to 0.20 inch**.
- 10.1. If gap is not within limits, adjust forward or aft cargo hook manual release cable (Task 16-35.1).

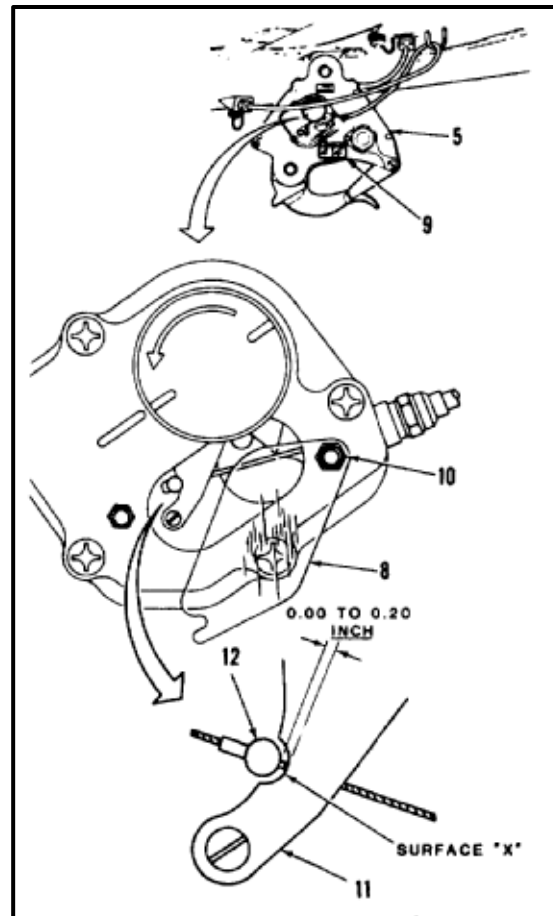

11. Position window on bolt (10). Torque bolts to **40 inch-pounds**.
12. Lockwire bolts (10). Use lockwire (E231).

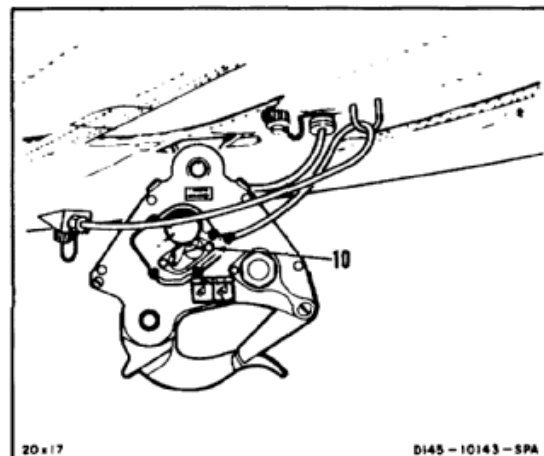
**FOLLOW-ON MAINTENANCE:**

None

END OF TASK

INITIAL SETUP

**Applicable Configurations:**

All

**Tools:**

- Aircraft Mechanic's Tool Kit, NSN 5180-00-323-4692
- Stopwatch
- Stowage Coupling, MS3180-16C
- Regulator
- Pressure Gage, 0 to 30 psi
- Shutoff Valve
- Torque Wrench, 30 to 150 Inch-Pounds
- Air Hose
- Source of Low Pressure Compressed Air

**Materials:**

None

**Parts:**

Packing

**Personnel Required:**

- Medium Helicopter Repairer
- Aircraft Electrician
- Inspector

**Equipment Condition:**

- Battery Disconnected (Task 1-39)
- Electrical Power Off
- Hydraulic Power Off
- Air Pressure Test Setup

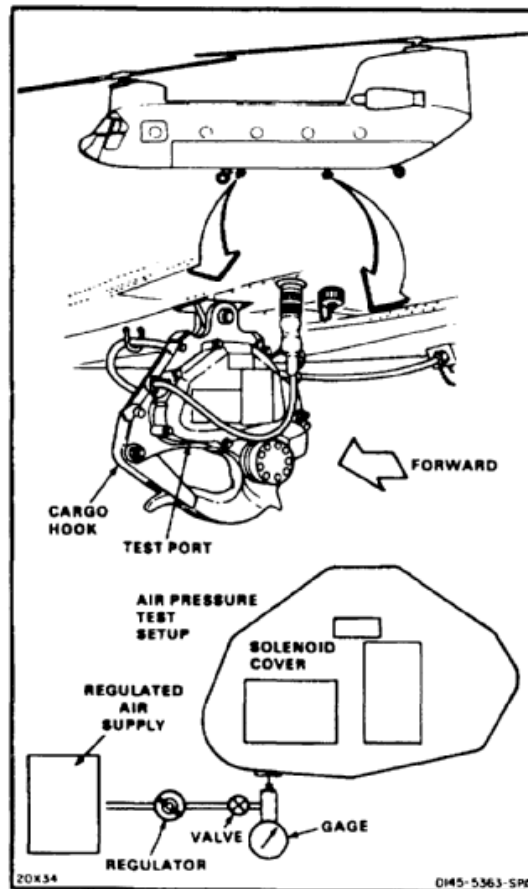

**NOTE**

Procedure is same to test forward or aft cargo hook.

1. Disconnect connector plug (1) from receptacle (2).
2. Install stowage coupling (3) on connector plug (1).

**NOTE**

Only solenoid cover of cargo hook is shown here for clarity.

3. Remove, bolt (4), washer (5), and packing (6) from test port (7) of solenoid cover (8).

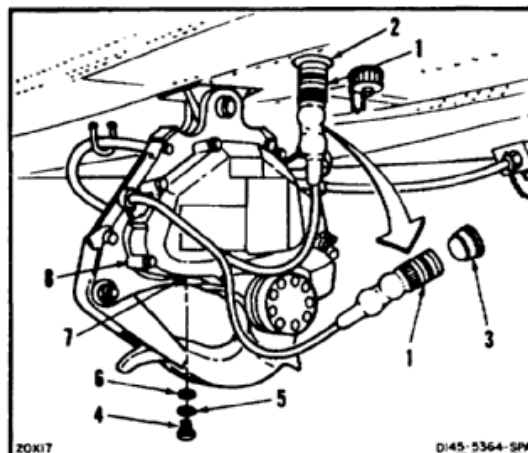

4. Close valve (9) of test setup. Connect test setup to air supply (10).
5. Adjust regulator (11) to **0 psi**.
6. Connect test setup to test port (7).

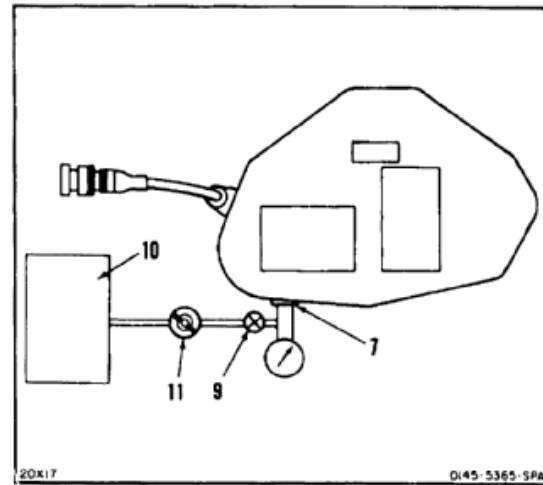

7. Open valve (9).

**WARNING**

Do not apply more than **10 psi** air pressure to test port. Otherwise, damage to solenoid cover or injury to personnel can occur.

8. Adjust regulator (11) for **5.5 psi** on gage (12).
9. Close valve (9). Adjust air supply regulator (11) to **0 psi**.
10. Check gage (12) for pressure loss. There shall be no pressure loss for **30 minutes**.

**INSPECT**

11. Open valve (9) and reduce pressure at port (7) to **0 psi**.
12. Disconnect test setup from port (7) and from air supply (10).

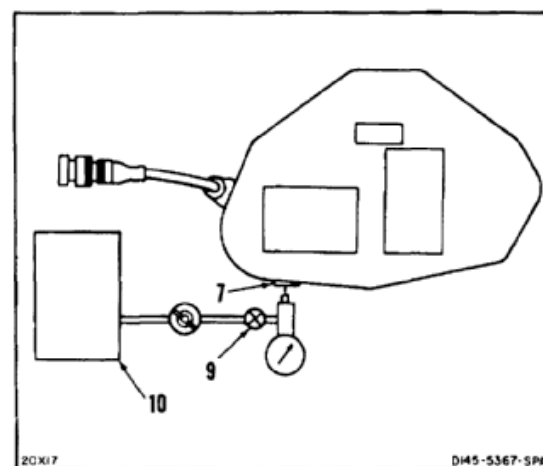
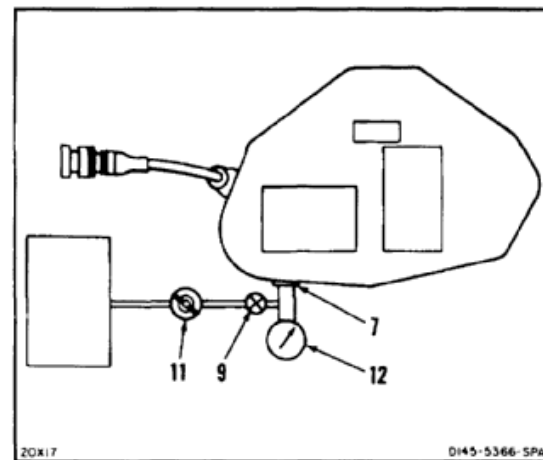

13. Install packing (6), washer (5), and bolt (4) in port (7). Torque bolt to **50 inch-pounds**.
14. Remove stowage coupling (3) from connector plug (1).
15. Connect connector plug (1) to receptacle (2).

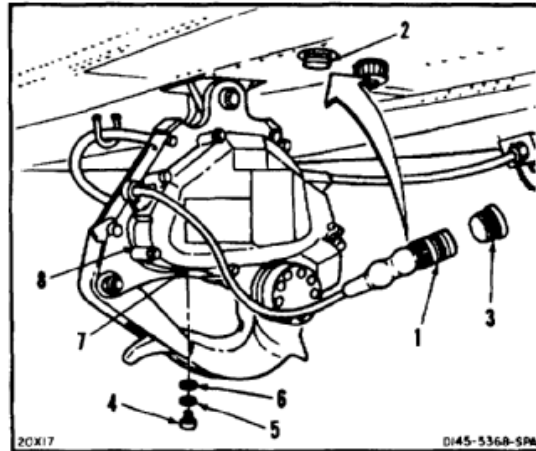
**INSPECT****FOLLOW-ON MAINTENANCE:**

None

END OF TASK

**16-100**

## INITIAL SETUP

**Applicable Configurations:**

All

**Tools:**

Aircraft Mechanic's Tool Kit, NSN 5180-00-323-4692

**Materials:**

None

**Personnel Required:**

Medium Helicopter Repairer

**Equipment Condition:**

Battery Disconnected (Task 1-39)  
 Electrical Power Off  
 Hydraulic Power Off

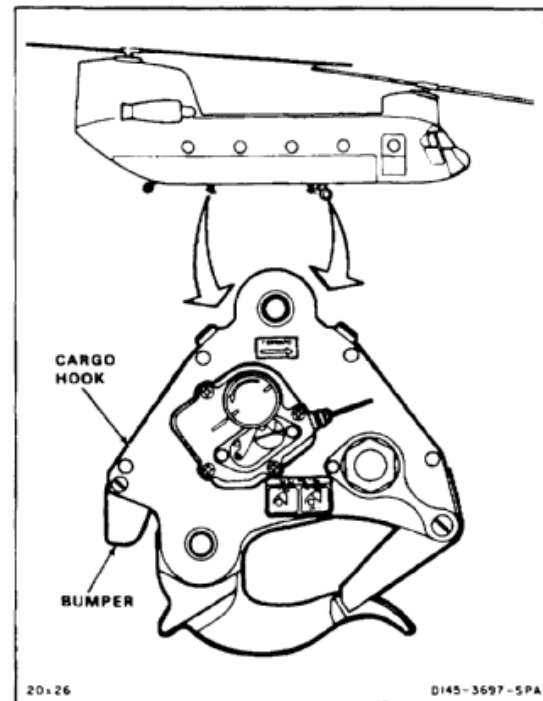
**NOTE**

Procedure is same to remove bumper on forward or aft cargo hooks.

1. Remove cotter pin (1), nut (2), two washers (3), and bolt (4) from cargo hook (5).
2. Remove bumper (6). Use soft faced hammer.

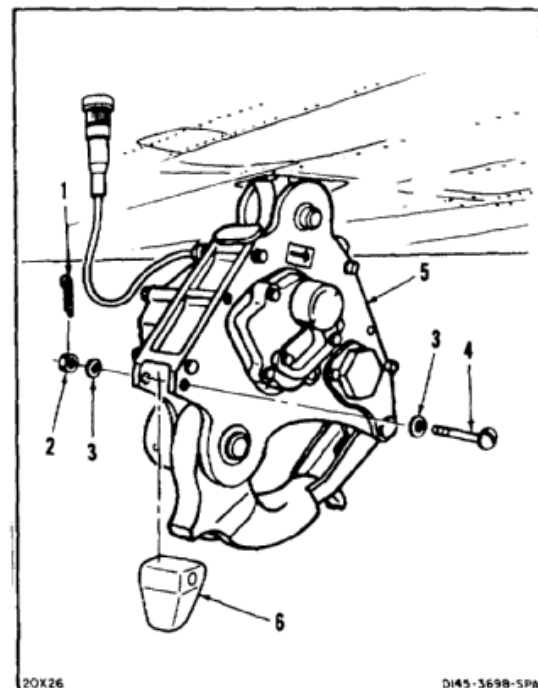
**FOLLOW-ON MAINTENANCE:**

None

END OF TASK

## INITIAL SETUP

**Applicable Configurations:**

All

**Tools:**

Aircraft Mechanic's Tool Kit, NSN 5180-00-323-4692

**Materials:**

None

**Parts:**

Cotter Pin

**Personnel Required:**Medium Helicopter Repairer  
Inspector**References:**

TM 55-1520-240-23P

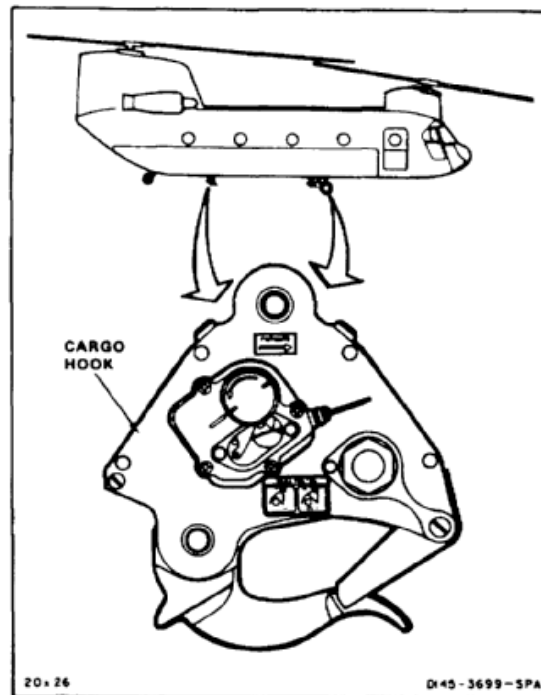
**NOTE**

Procedure is same to install bumper on aft cargo hook.

Bumper must be tight fit. Do not trim or cut.

1. Position bumper (1) in cargo hook (2). Use soft faced hammer.
2. Install bolt (3), two washers (4), nut (5), and cotter pin (6).

**INSPECT****FOLLOW-ON MAINTENANCE:**

Perform operational check of cargo hook (TM 55-1520-240-T).

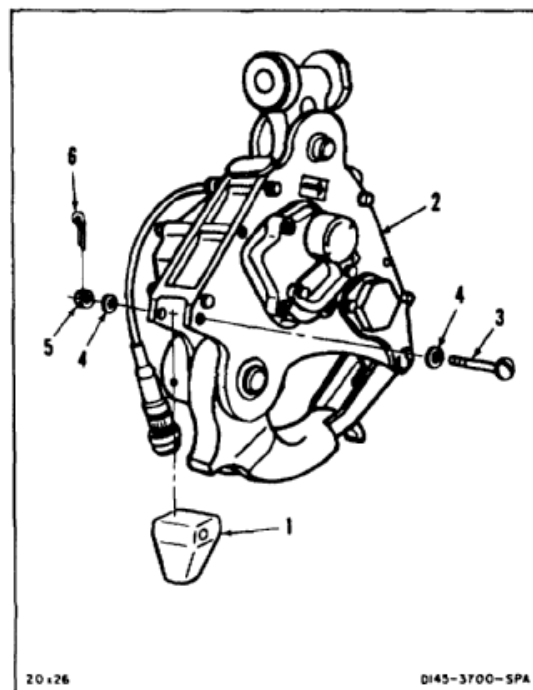

END OF TASK

INITIAL SETUP

**Applicable Configurations:**

All

**Tools:**

Electrical Repairer's Tool Kit, NSN 5180-00-323-4915  
 Insertion/Extraction Tool

**Materials:**

Paper Tags (E264)

**Personnel Required:**

Aircraft Electrician

**Equipment Conditions:**

Battery Disconnected (Task 1-39)  
 Electrical Power Off

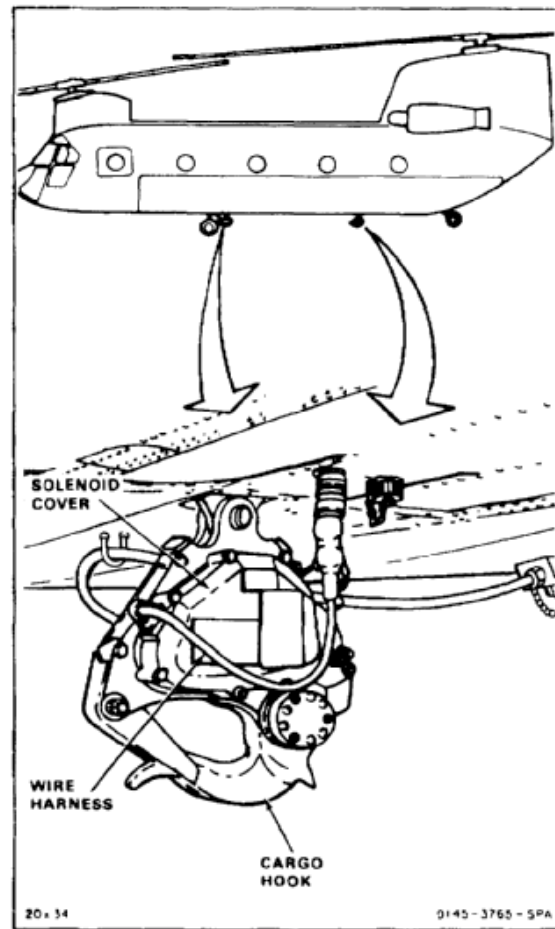

**NOTE**

Procedure is same to remove solenoid cover or wire harness on forward or aft hook.

1. Disconnect cable plug (1).
2. Remove eight bolts (2) and washers (3) from solenoid cover (4).

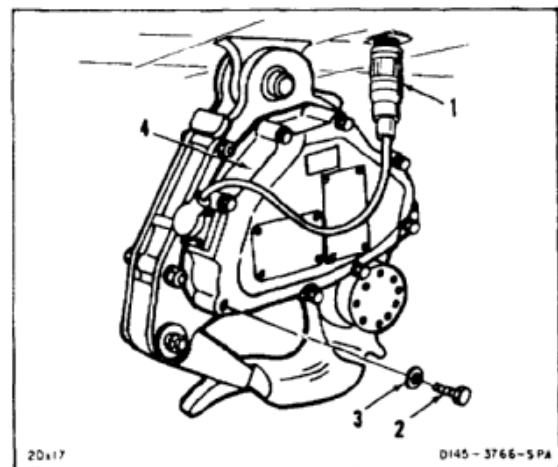

**NOTE**

Wires are identified at manufacture. Before disconnecting any wire, make sure wire is identified.

3. Move solenoid cover (4) enough to gain access to harness wires (5). Disconnect eight harness wires (5) from modules (6). Use insertion/extraction tool.
4. Cut and remove strap (7). Remove solenoid cover (4) from cargo hook (8).

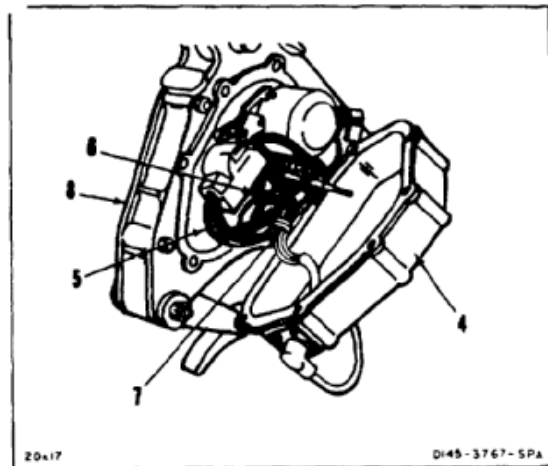

5. Remove gasket (9) from cargo hook (8).

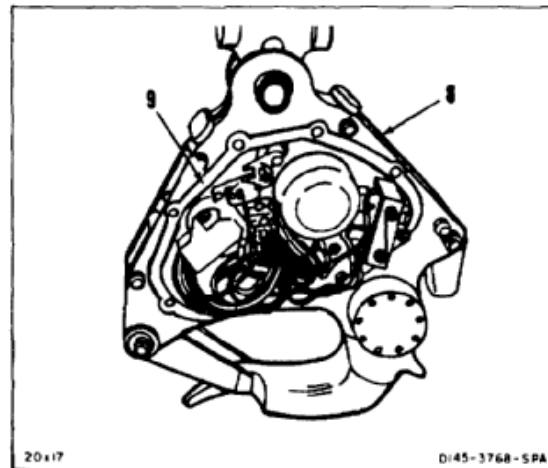

6. Remove lockwire from four screws (10). Remove four screws (10), four washers (11), and wire harness (12) from solenoid cover (4).
7. Remove gasket (13) from wire harness (12).

**FOLLOW-ON MAINTENANCE:**

None

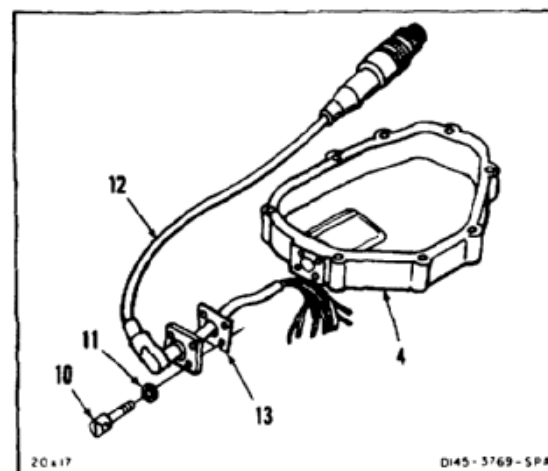

END OF TASK



## INITIAL SETUP

**Applicable Configurations:**

All

**Tools:**

Electrical Repairer's Tool Kit, NSN 5180-00-323-4915  
 Insertion/Extraction Tool  
 Self Clinching Strap, Hand Tool, NSN  
 5120-00-781-7891  
 Torque Wrench, 30 to 150 Inch-Pounds  
 Torque Screwdriver, 0 to 25 Inch-Pounds

**Materials:**

Gloves (E186)  
 Lockwire (E227)  
 Straps (E377)  
 Sealant (E340.1)

**Parts:**

Gaskets

**Personnel Required:**

Aircraft Electrician  
 Inspector

**References:**

TM 55-1520-240-23P

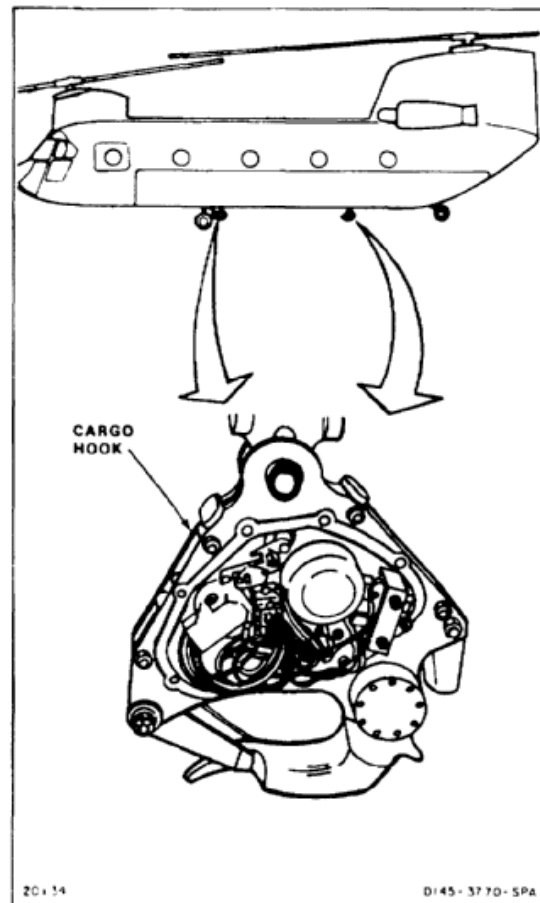

**NOTE**

Procedure is same to install solenoid cover or wire harness on forward or aft hook.

1. Install gasket (1) on wire harness (2).
2. Feed wire harness (2) through hole (3) in solenoid cover (4).
3. Install four screws (5) and washers (6). Torque screws to **9 inch-pounds**. Lockwire screws. Use lockwire (E227).

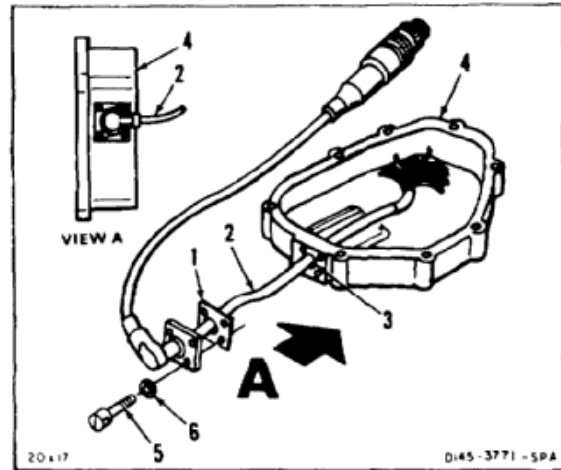
**WARNING**

Sealant (E340.1) can irritate skin and cause burns. Avoid contact with skin, eyes, or clothing. In case of contact, immediately flush skin or eyes with water for at least **15 minutes**. Get medical attention for eyes.

- 3.1. Apply sealant (E340.1) around harness (2) where it comes through cover (4). Wear gloves (E186).
4. Position gasket (7) on cargo hook (8).
5. Remove any tags and connect eight harness wires (9) to modules (10). Use insertion/extraction tool.
6. Route wire harness (2) below modules (10) and tie harness to wires from solenoid protection switch (11). Tie harness and wires with strap (E377) (12).

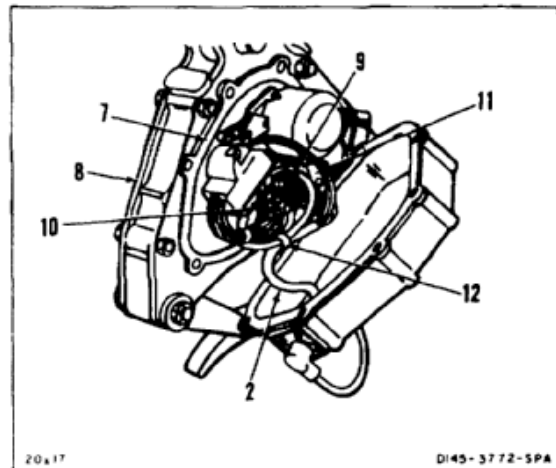

**16-16 INSTALL FORWARD OR AFT CARGO HOOK SOLENOID COVER OR WIRE HARNESS (Continued)**

16-16

7. Position solenoid cover (4) on cargo hook (8) and install eight bolts (13) and washers (14).
- 7.1. Follow torque sequence shown. Torque bolts (13) alternately to **60 inch-pounds**. Repeat sequence to check torque.

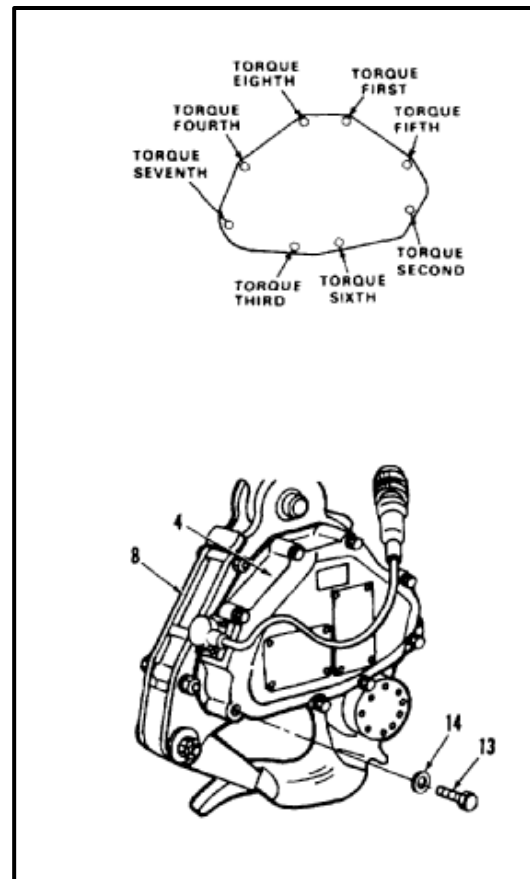

8. Connect cable plug (15) to receptacle (16).

**INSPECT****FOLLOW-ON MAINTENANCE:**

Perform operational check of cargo hook (TM 55-1520-240-T).

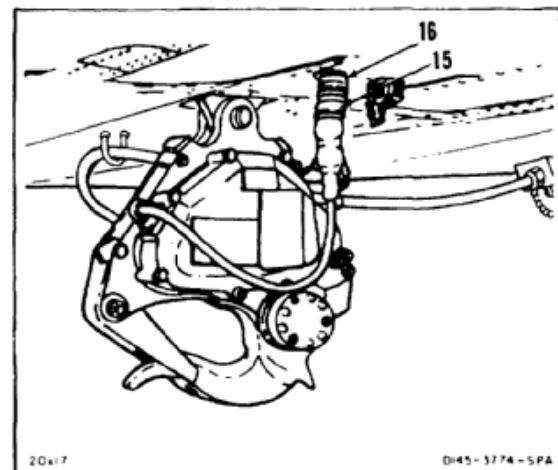

END OF TASK

## INITIAL SETUP

**Applicable Configurations:**

All

**Tools:**

Aircraft Mechanic's Tool Kit, NSN 5180-00-323-4692

**Materials:**

None

**Personnel Required:**

Medium Helicopter Repairer

**Equipment Condition:**

Battery Disconnected (Task 1-39)  
Electrical Power Off

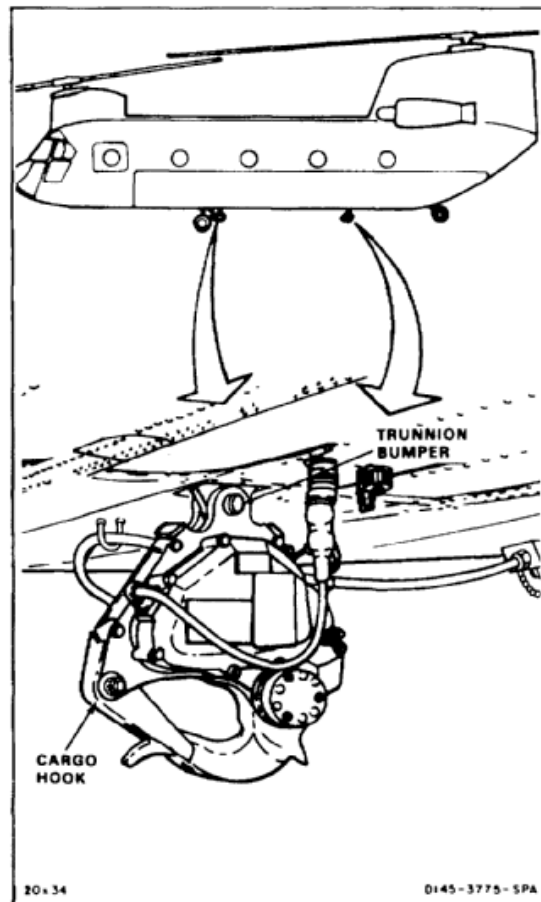
**NOTE**

Procedure is same to remove trunnion bumpers on forward or aft cargo hook.

1. Remove sealant from two bumpers (1). Use putty knife.
2. Remove bumpers (1) from trunnion fitting (2).

**FOLLOW-ON MAINTENANCE:**

None

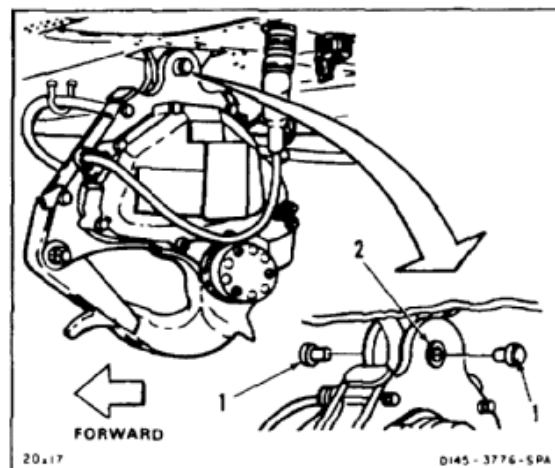

END OF TASK

**16-18 INSTALL FORWARD OR AFT CARGO HOOK TRUNNION BUMPERS**

16-18

**INITIAL SETUP****Applicable Configurations:**

All

**Tools:**

Aircraft Mechanic's Tool Kit, NSN 51 80-00-323-4692

**Materials:**

Adhesive, Loctite 404 (E343)  
 Cloths (E120)  
 Methyl-Ethyl-Ketone (E244)

**Personnel Required:**

Medium Helicopter Repairer  
 Inspector

**References:**

TM 55-1520-240-23P

**General Safety Instructions:****WARNING**

Methyl-ethyl-ketone (E244) is flammable. It can irritate skin and cause burns. Use only with adequate ventilation, away from heat or open flame. Avoid contact with skin, eyes, or clothing. In case of contact, immediately flush skin or eyes with water for at least **15 minutes**. Get medical attention for eyes.

**NOTE**

Procedure is same to install forward or aft cargo hook trunnion bumpers.

1. Clean shank area of bumpers (1) and ID of holes (2) in trunnion fitting (3). Use a clean cloth (E120) dampened with MEK (E244).
2. Apply a bead of adhesive (E343) around ID of holes (2).
3. Immediately install two bumpers (1). Use a soft faced hammer.

**INSPECT****FOLLOW-ON MAINTENANCE:**

None

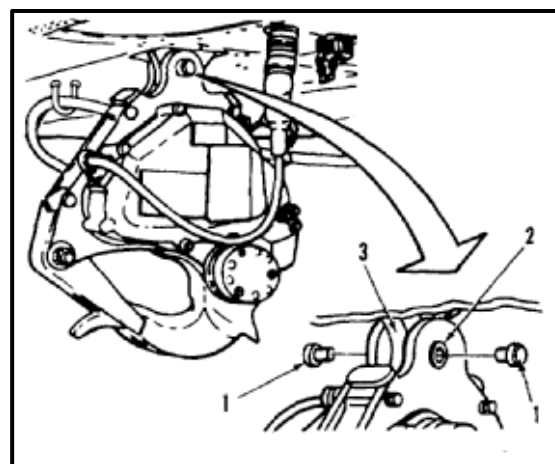
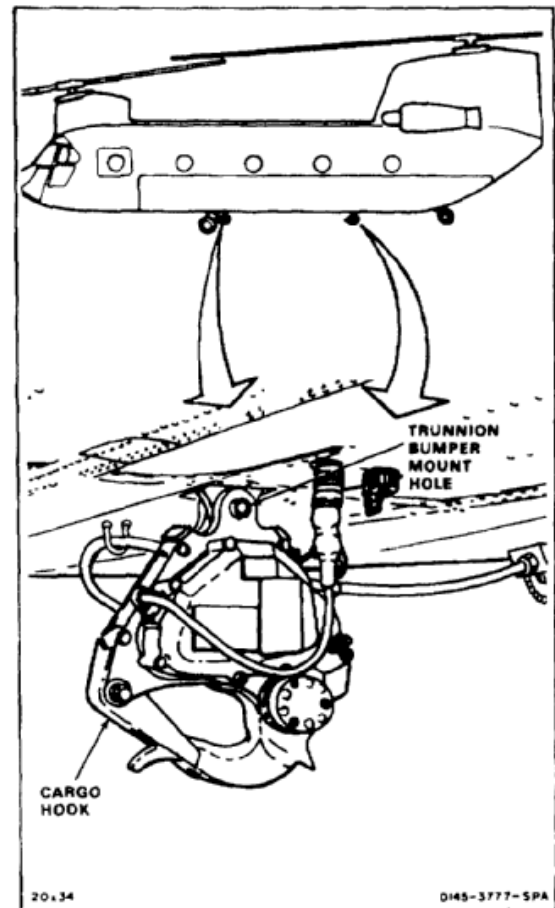

END OF TASK

INITIAL SETUP

**Applicable Configurations:**

All

**Tools:**

Aircraft Mechanic's Tool Kit, 5180-00-323-4692

**Materials:**

None

**Personnel Required:**

Medium Helicopter Repairer

**Equipment Condition:**

Battery Disconnected (Task 1-39)  
 Electrical Power Off  
 Hydraulic Power Off

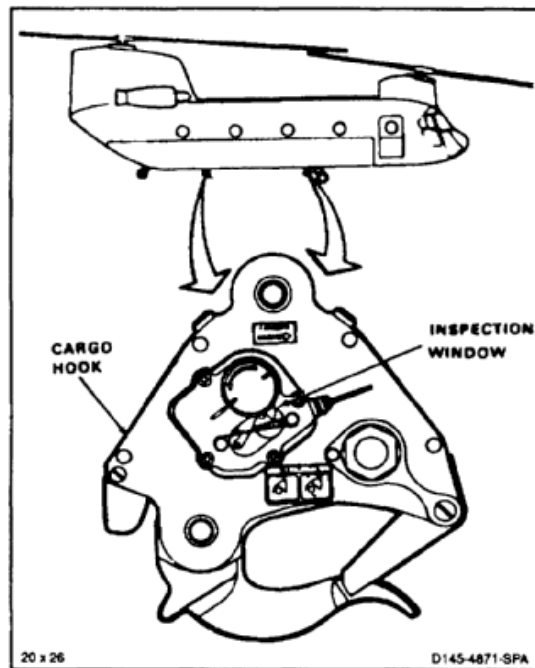

**NOTE**

Procedure is same to remove inspection window from forward or aft cargo hook.

1. Remove lockwire and loosen bolt (1). Remove bolt (2) and washer (3).
2. Remove inspection window (4).

**FOLLOW-ON MAINTENANCE:**

None

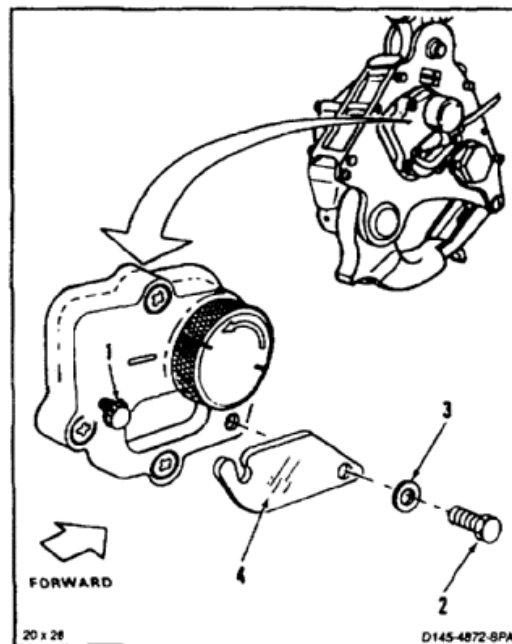

END OF TASK

## INITIAL SETUP

**Applicable Configurations:**

All

**Tools:**

Aircraft Mechanic's Tool Kit, NSN 5180-00-323-4692  
Torque Wrench, 30 to 150 Inch-Pounds

**Materials:**

Lockwire (E231)

**Personnel Required:**

Medium Helicopter Repairer  
Inspector

**References:**

TM 55-1520-240-23P

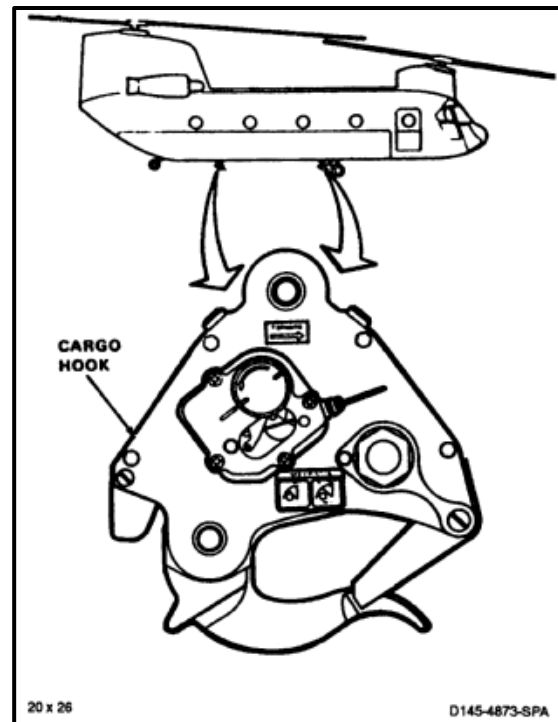
**NOTE**

Procedure is same to install inspection window on forward or after cargo hook.

1. Position inspection window (1). Install bolt (2) and washer (3). Make sure slotted end of window is tight against bolt (4).
2. Torque bolts (2 and 4) to **40 inch-pounds**.
3. Lockwire bolts (2 and 4) to each other and to cable adaptor (5). Use lockwire (E231).

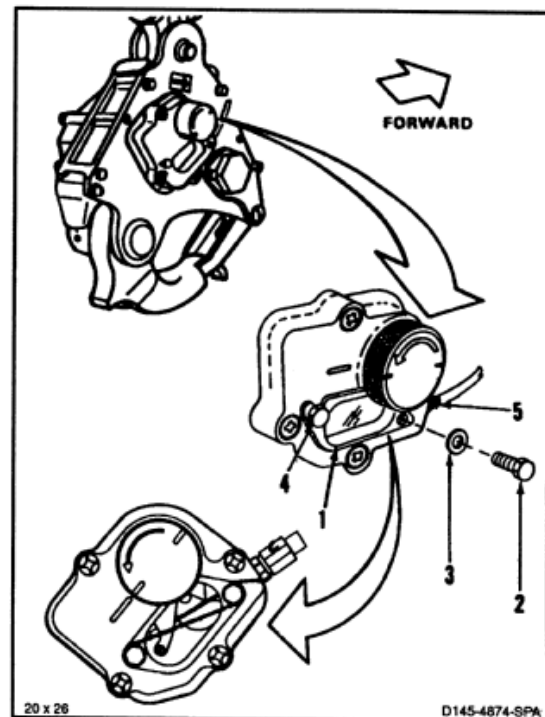
**INSPECT****FOLLOW-ON MAINTENANCE:**

None

END OF TASK

## INITIAL SETUP

**Applicable Configurations:**

All

**Tools:**

Aircraft Mechanic's Tool Kit, NSN 5180-00-323-4692

**Materials:**

None

**Personnel Required:**

Medium Helicopter Repairer

**Equipment Condition:**

Battery Disconnected (Task 1-39)

Electrical Power Off

Hydraulic Power Off

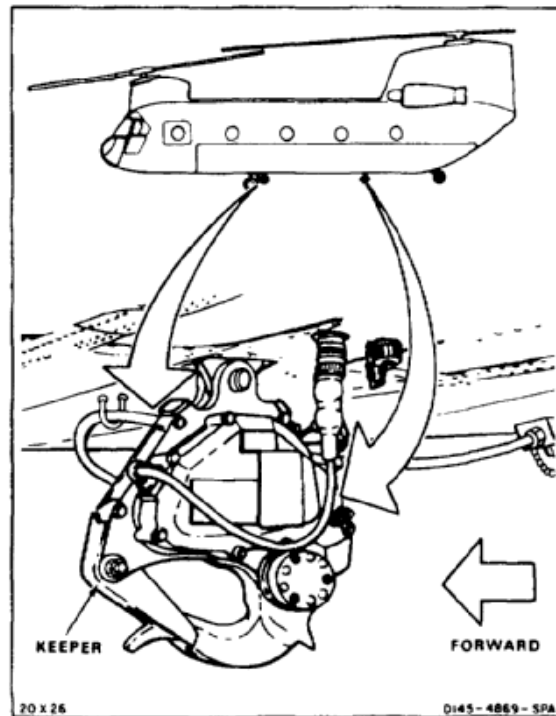
**NOTE**

Procedure is same to remove keeper from forward or aft cargo hook.

1. Remove cotter pin (1), nut (2), two washers (3), and bolt (4).
2. Remove keeper (5).
3. Remove bushing (6) and spring (7) from keeper (5).

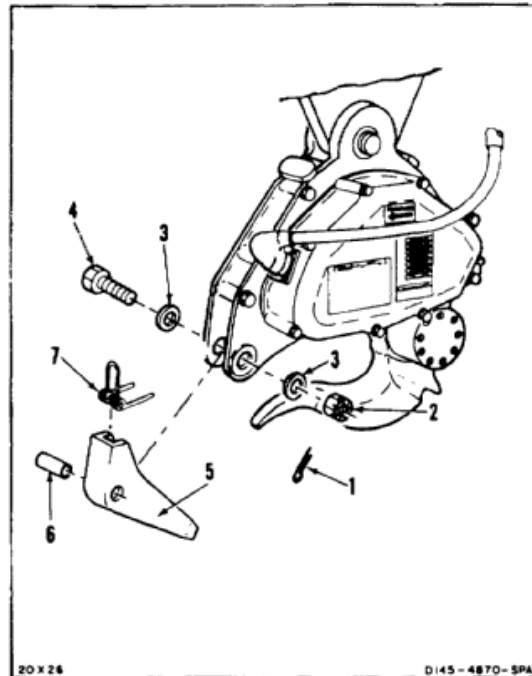
**FOLLOW-ON MAINTENANCE:**

None

END OF TASK

16-112



**INITIAL SETUP**

**Applicable Configurations:**

All

**Tools:**

Aircraft Mechanic's Tool Kit, NSN 5180-00-323-4692

**Materials:**

None

**Parts:**

Cotter Pin

**Personnel Required:**

Medium Helicopter Repairer  
Inspector

**References:**

TM 55-1520-240-23P

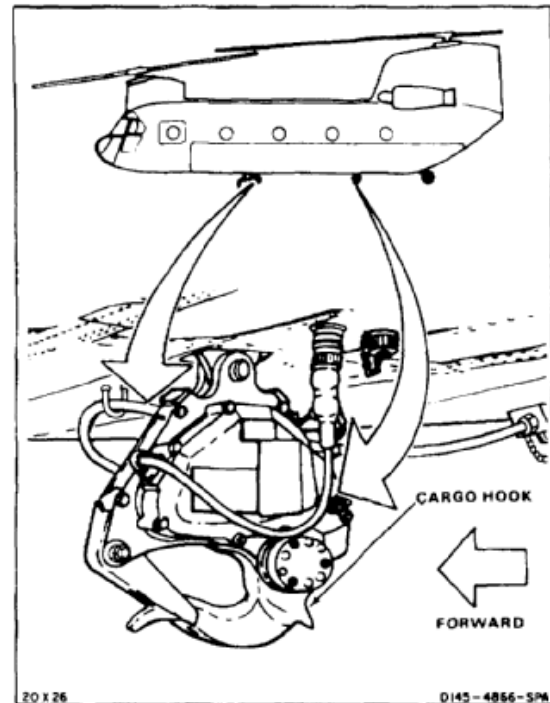

**NOTE**

Procedure is same to install keeper on forward or aft cargo hook.

1. Position spring (1) in keeper (2), closed end of spring up. Install bushing (3) through keeper and spring.
2. Install keeper (2) in cargo hook (4) with closed end of spring (1) positioned under projection (5) of rear cover (6). Use flat end of cotter pin extractor (7) to position spring.
3. Install bolt (8), two washers (9), and nut (10). Install cotter pin (11).
4. Cycle keeper (2) open and closed two times to ensure proper assembly.

**INSPECT**

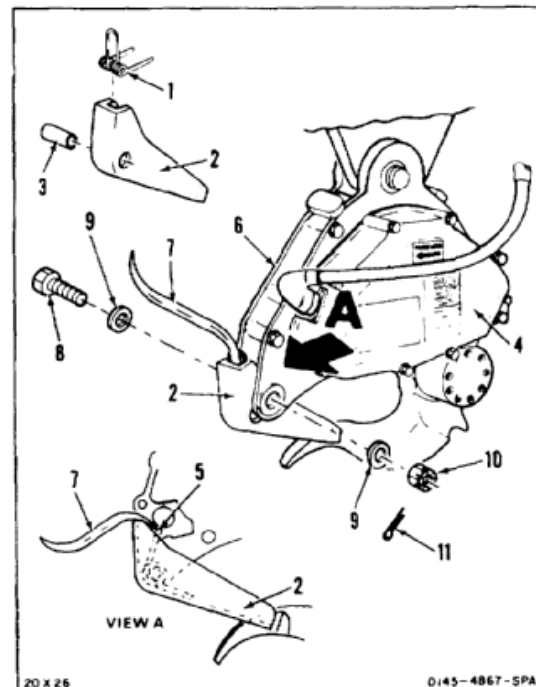

**FOLLOW-ON MAINTENANCE:**

None

END OF TASK

INITIAL SETUP

**Applicable Configurations:**

All

**Tools:**

Aircraft Mechanic's Tool Kit, NSN 5180-00-323-4692  
Torque Wrench, 30 to 150 Inch-Pounds

**Materials:**

None

**Personnel Required:**

Medium Helicopter Repairer (2)

**Equipment Condition:**

Battery Disconnected (Task 1-39)  
Electrical Power Off  
Hydraulic Power Off

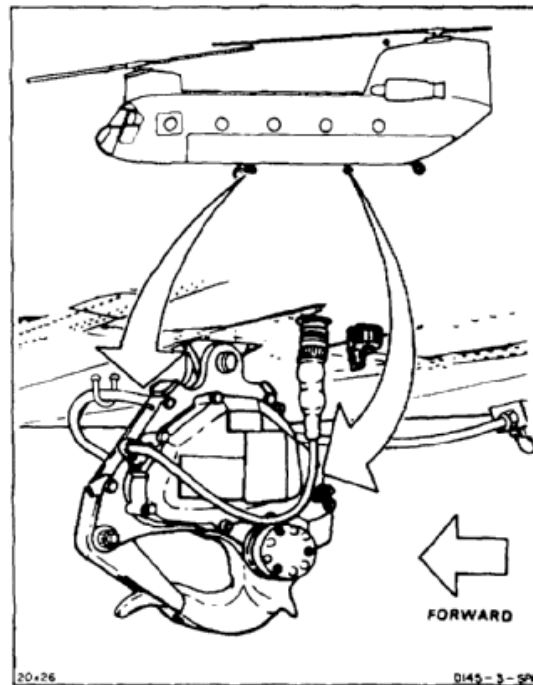

**NOTE**

Forward and aft cargo hooks are removed in same way.

1. Loosen lockring (1) and disconnect plug from receptacle (2).
2. Remove cap (3) from stowed position. Install on receptacle (2).

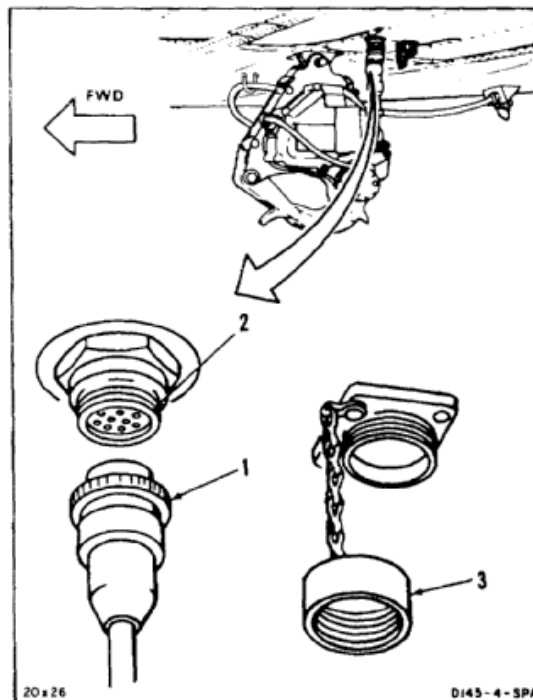

16-23 REMOVE FORWARD OR AFT CARGO HOOK (Continued)

3. Remove lockwire and loosen bolt (4). Remove bolt (5) and washer (6).
4. Remove inspection window (7).

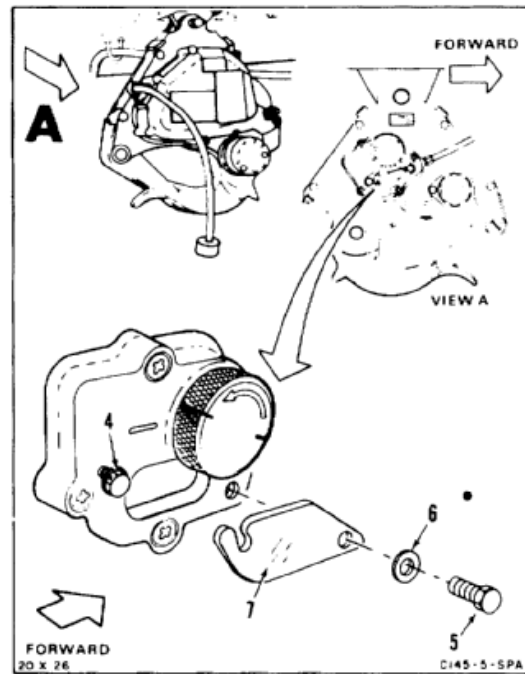

5. Move release arm (8) down and hold. Loosen screw (9). Remove cable (10) from arm (8).
6. Remove lockwire from nut (11). Loosen nut and disconnect cable (12).

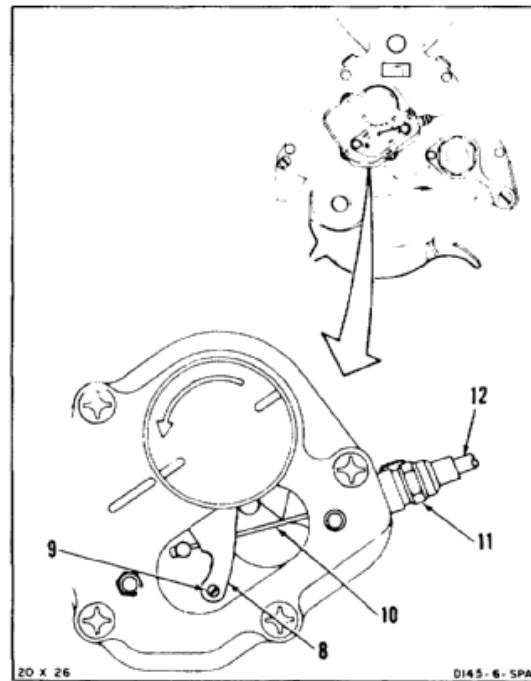

7. Position inspection window (7). Install bolt (5) and washer (6). Make sure slotted end of window is tight against bolt (4).

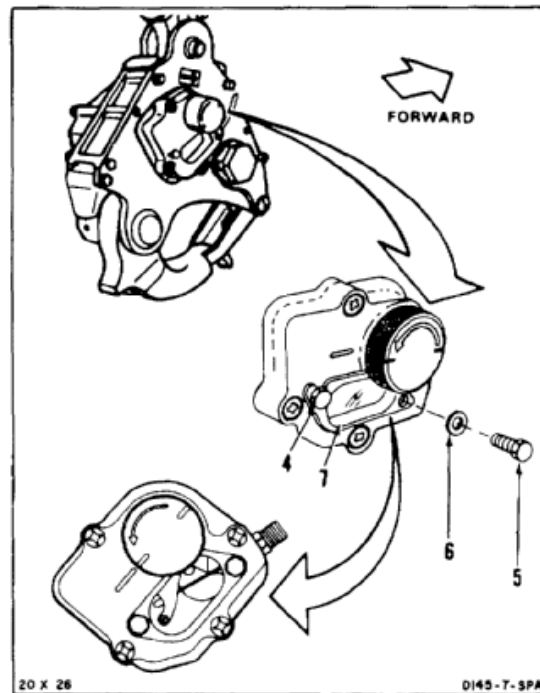

8. Remove screw (13). Remove forward access plate (14) from fuselage.
9. Remove screw (15). Remove aft access plate (16) from fuselage.

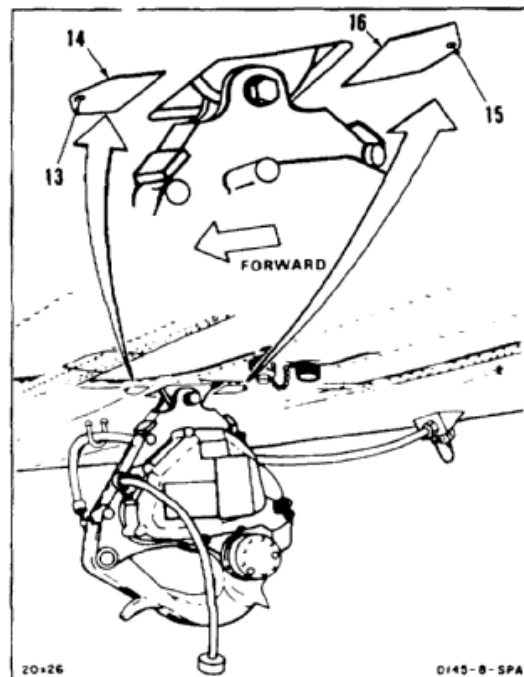

**16-23 REMOVE FORWARD OR AFT CARGO HOOK (Continued)**

16-23

10. Remove nut (17) and washer (18) from pivot bolt (19).
11. Have helper support weight of cargo hook (20).
12. Press safety stop (21) and remove bolt (19).
13. Remove cargo hook (20).

**NOTE**

If cargo hook will not be replaced immediately, perform steps 14 thru 22.

14. Press safety stop (21) and install bolt (19), washer, and nut (17). Torque nut to **120 inch-pounds**.

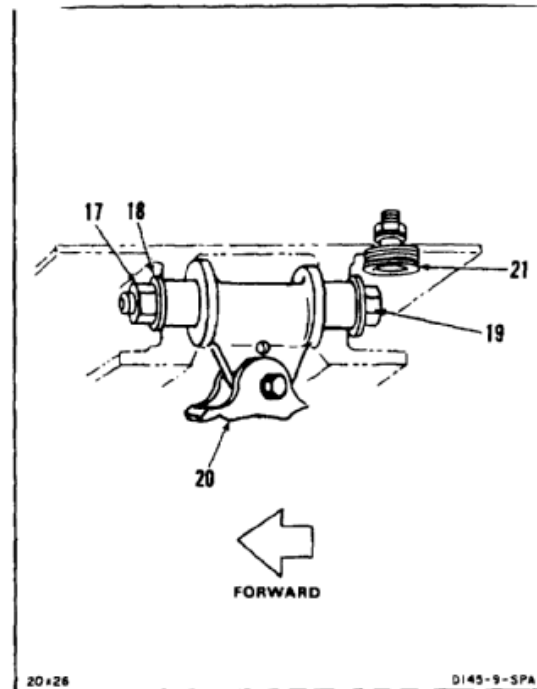

15. Loosen nut (22).
16. Slide sleeve (23) down cable (24).
17. Remove cable ball end (25) from inner cable attachment (26). Remove sleeve (23) and cable (24).
18. Remove cap (27) from stowage fitting (28). Install cap on fitting (29).

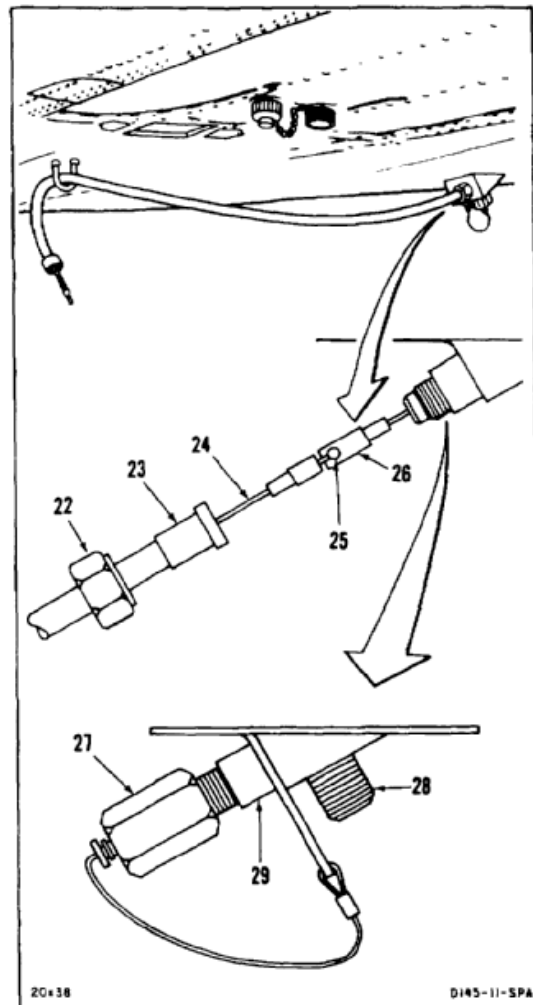

**16-23 REMOVE FORWARD OR AFT CARGO HOOK (Continued)**

16-23

19. Position forward access plate (14) over forward hole in fuselage with clip slot (30) around rivet tail (31).
20. Install screw (13).
21. Position aft access plate (16) over aft hole in fuselage with clip slot (32) around rivet tail (33).
22. Install screw (15).

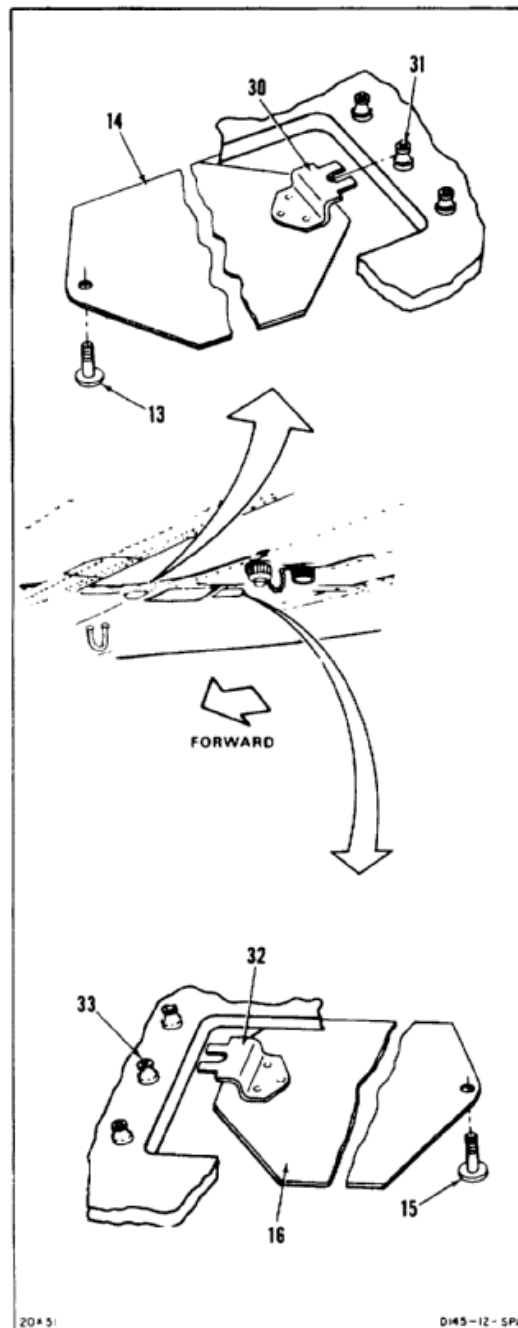
**FOLLOW-ON MAINTENANCE:**

None

END OF TASK

INITIAL SETUP

**Applicable Configurations:**

All

**Tools:**

- Electrical Instrument Shop Set, NSN 4920-00-165-1453
- Tool Crib Shop Set, NSN 4920-00-472-4183
- Sheet Metal Shop Set, NSN 4920-00-166-5505
- Aircraft Mechanic's Tool Kit, NSN 5180-00-323-4692
- Aircraft Technical Inspection Tool Kit, NSN 5180-00-323-5114
- Contact Insertion/Extraction Tool (M83723/31-16)
- Arbor Press
- Crowfoot Attachment, 1-15/16 Inch Brass, Round Stock, 1/8 Inch X 6 Inch

**Materials:**

- Cloths (E120)
- Paper Tags (E264)

**Personnel Required:**

- Machinist
- Medium Helicopter Repairer
- Aircraft Electrician
- Inspector

**References:**

- TM 55-1500-322-24

**Equipment Condition:**

- Off Helicopter Task

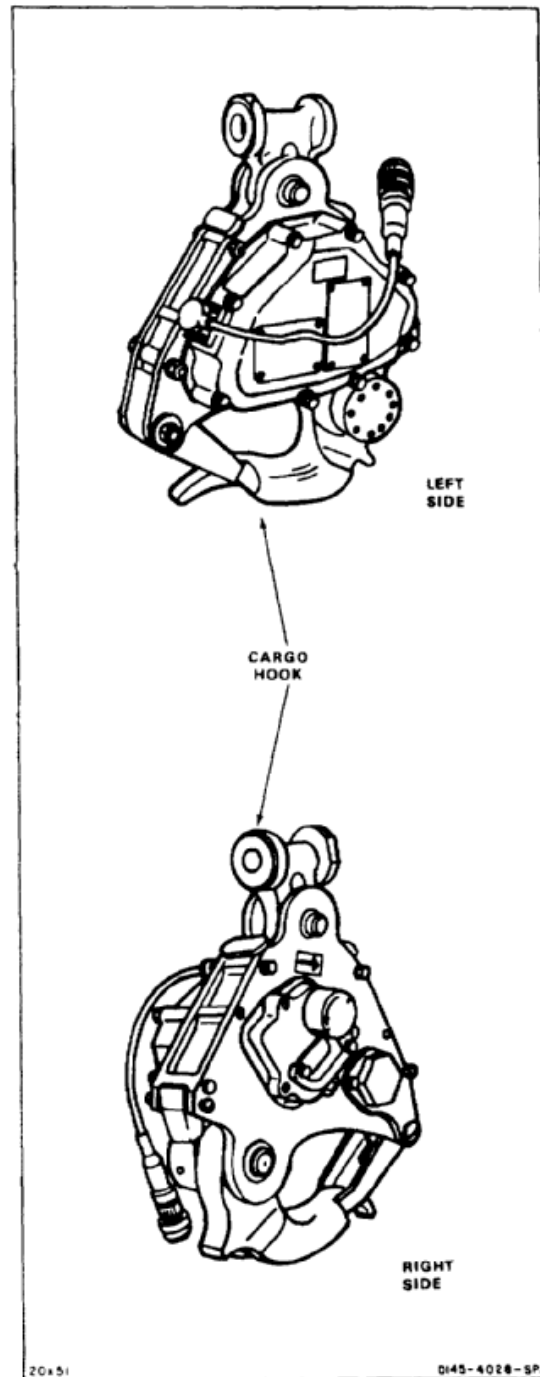



**16-24 DISASSEMBLE AND INSPECT FORWARD OR AFT CARGO HOOK (AVIM) (Continued)**

1. Remove lockwire and remove two bolts (1), washers (2), and inspection window (3).
2. Remove four screws (4). Remove cover (5) from hook (6).
- 2.1. Inspect window (3) and cover (5). There shall be no cracks.

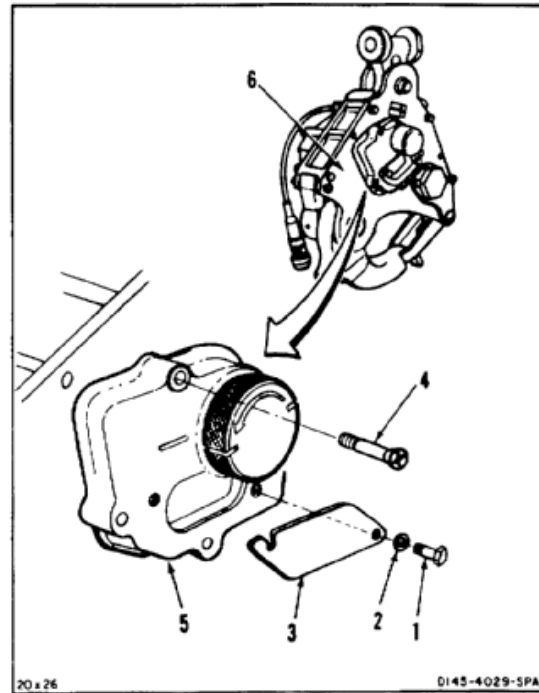

3. Remove pin (7) and arm (8) from cover (5).
4. Remove pin (9) and spring (10) from arm (8).
5. Remove cable adapter (11) from cover (5).

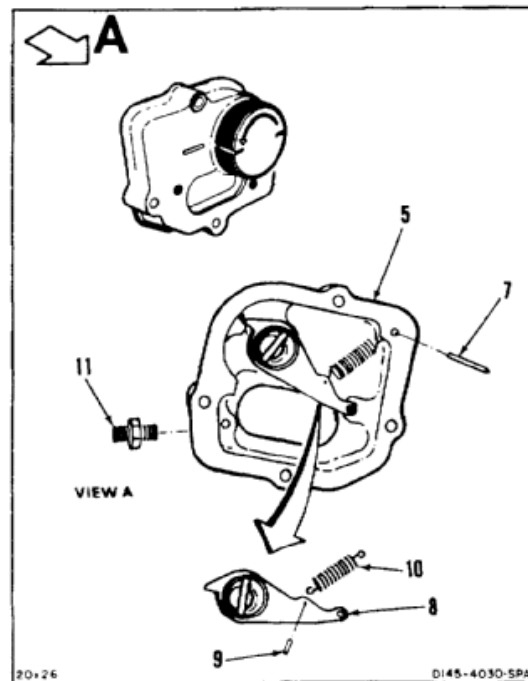

6. Remove pin (12) and knob (13) from knob retainer (14). Use **1/8-inch** brass rod.

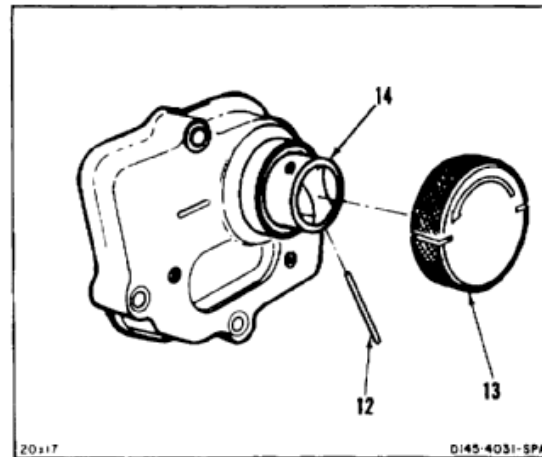

7. Remove knob retainer (14) and retainer plug (15) from cover (5).
8. Remove retaining ring (16) and seal (17).

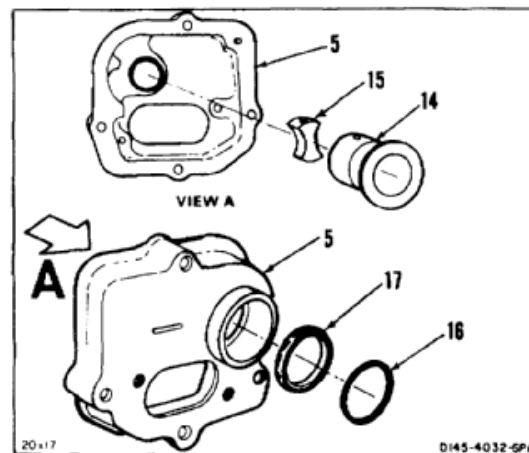

**NOTE**

Bumper is tight fit.

9. Remove cotter pin (18), nut (19), two washers (20), bolt (21), and bumper (22).
- 9.1. Inspect bumper (22). There shall be no loss of material.
10. Remove cotter pin (23), nut (24), two washers (25), bolt (26), and keeper (27).
- 10.1. Inspect keeper (27). There shall be no cracks.
11. Remove bushing (28) and spring (29) from keeper (27).

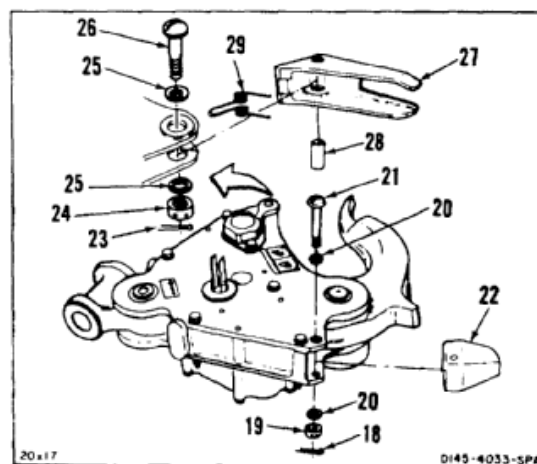

- 12. Remove lockwire, bolt (30), packing (30.1), and washer (30.2).
- 12.1. Remove eight bolts (31) and washers (31.1) from cover (32).

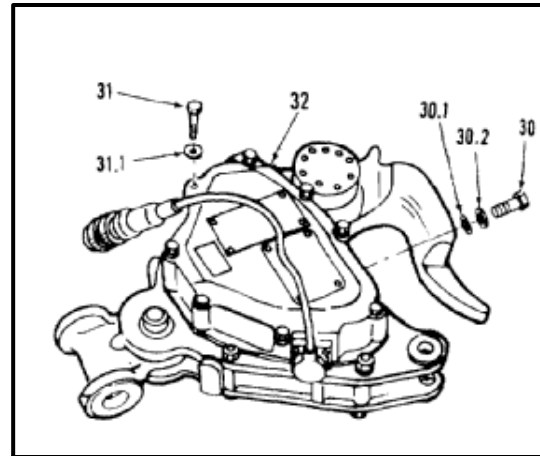

**NOTE**

Wires are identified at manufacture. Before disconnecting any wire, make sure wire is identified.

- 13. Raise cover (32).
- 14. Disconnect eight harness wires (33) from modules (34). Use contact insertion/extraction tool.
- 15. Remove strap (35).
- 16. Remove cover (32) and gasket (36).
- 16.1. Inspect cover (32). There shall be no cracks.

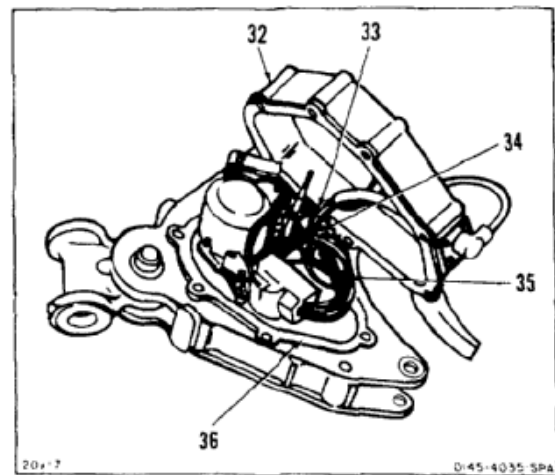

- 17. Remove lockwire, four screws (37), and four washers (38). Remove wire harness (39) and gasket (40) from cover (32).
- 17.1. Inspect boot (40.1). There shall be no cracks, cuts, or other damage that lets moisture into harness (39).

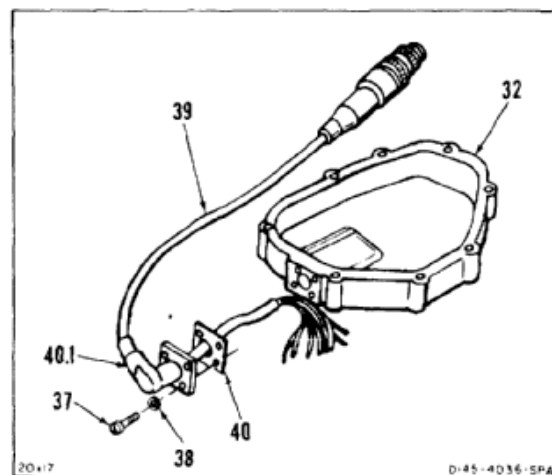

18. Disconnect all wires (41) from six modules (42). Use contact insertion/extraction tool. Remove two remaining straps (35).

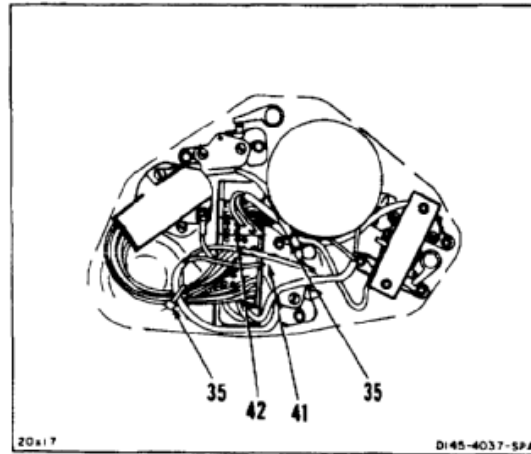

**NOTE**

Lock bar does not come off module rail.

19. Loosen screw (43) and slide lock bar (44) away from modules (42).
20. Tag (E264) and remove six modules (42). Slide modules to right and lift out.
21. Remove lockwire, three screws (45), three washers (46), ground wire (47), and relay (46).

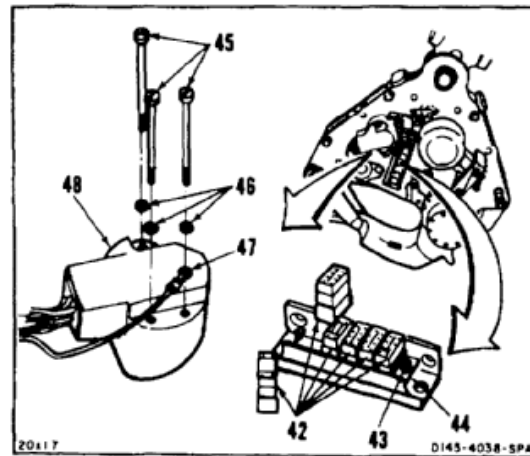

22. Remove lockwire, six screws (49), six washers (50), and three switches (51). Tag (E264) switches.
- 22.1. Inspect slots (51.1) in switches (51). There shall be no distortion.
23. Remove lockwire, two screws (52), two washers (53), and bracket (54).
24. Remove lockwire, two screws (55), four washers (56), two nuts (57), and switch (58). Tag (E264) switch.

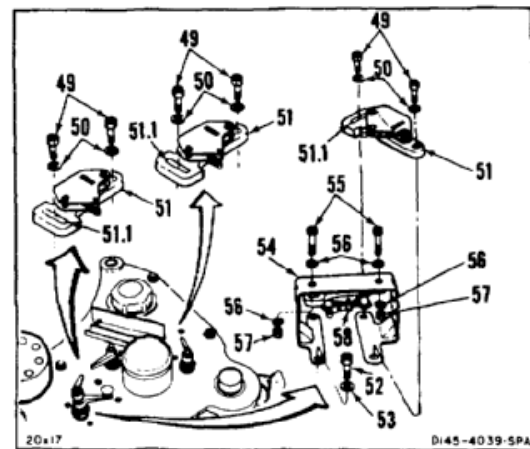

- 25. Remove six nuts (59), six washers (60), and two packings (61).

**WARNING**

Do not let cases separate when turning hook over, to prevent damage to equipment, or injury to personnel.

- 26. Turn hook (62) over and remove six bolts (63) and washers (64).

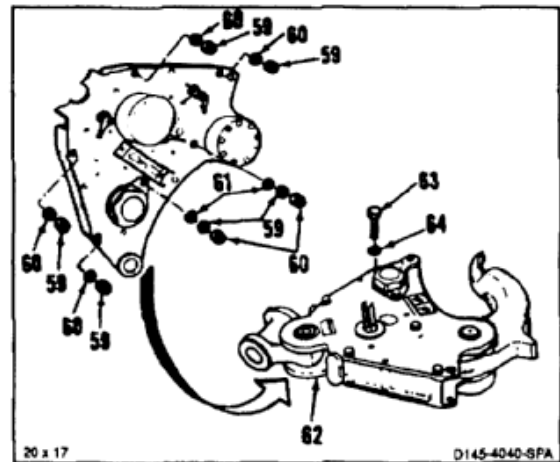

- 27. Work front plate (65) loose from rear plate (66).
- 28. Remove front plate (66).
- 29. Remove fitting (67) from rear plate (66).
- 30. Remove two bumpers (68) from fitting (67).

**INSPECT**

- 30.1. Measure outside diameter of boss (68.1) on side of fitting (67). Diameter of large boss shall not be less than **1.119 inches**. Diameter of small boss shall not be less than **1.056 inches**.
- 30.2. Measure inside diameter of bushing (68.2) in fitting (67). Diameter shall not be more than **1.022 inches**.

**NOTE**

Do not remove bushing unless worn.

- 30.3. Remove bushing (66.2) from fitting (67) if needed. Use arbor press.
- 31. Remove two bumpers (69) from rear plate (66).
- 32. Remove latch bumper (70) from rear plate (66).
- 32.1. Inspect bumpers (68,69, and 70). There shall be no cracks or loss of material.

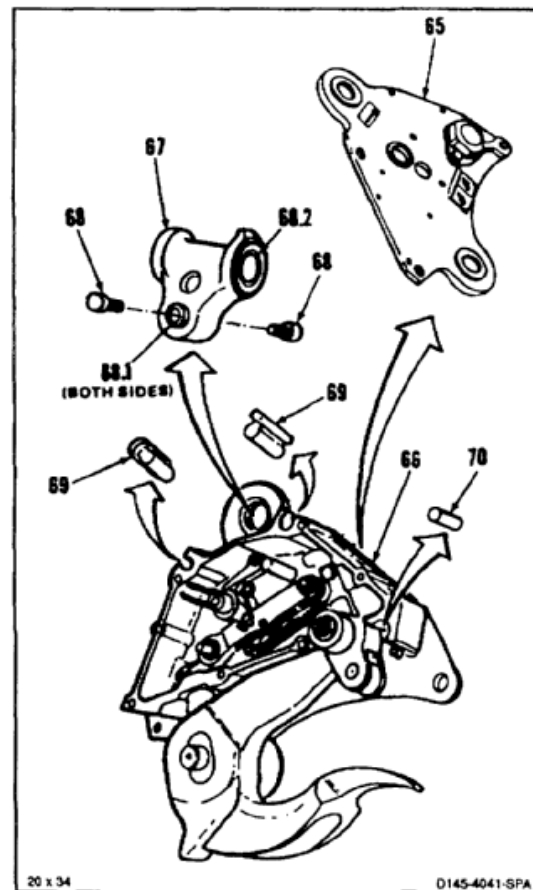

33. Hold latch (71) away from lever (72). Remove lever and pivot pin (73). Release latch.
34. Remove cotter pin (74), washer (75), and clevis pin (76).
35. Remove shaft (77) and spring (78) from lever (72). Do not remove link (78.1) from shaft (77).

**INSPECT**

- 35.1. Check free play between link (78.1) and arms of shaft (77). Total play shall be **0.025 to 0.035 inch**.
- 35.2. Check play of link (78.1) on its pivot pin. Play shall be between **0.004 and 0.008 inch**.

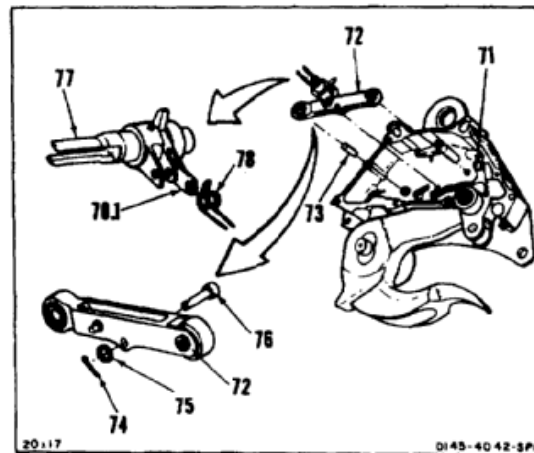

36. Disconnect spring (79) from retainer pin (80) and remove latch (71).
37. Remove lockwire, pin (81), and spring (78) from latch (71). Do not disassemble latch further.
38. Remove two cotter pins (82), nuts (83), and washers (84) from shaft (85). Remove two bearings (86) (TM 55-1500-322-24).
- 38.1. Inspect bearings (TM 55-1500-322-24).
39. Remove shaft (85) from latch (71).
- 39.1. Inspect surface (86.1). Surface shall be flat, with no gouges or depressions.

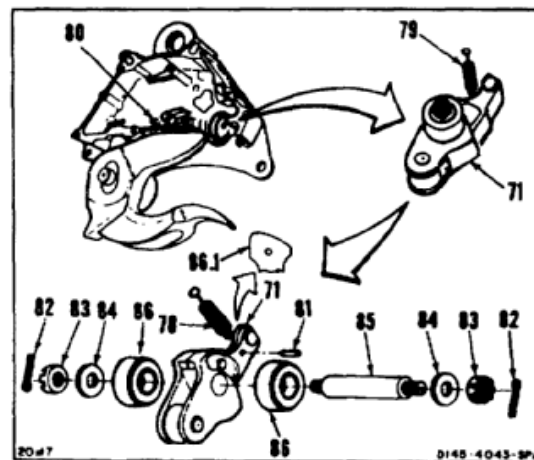

**WARNING**

Load beam spring return is preloaded. Be careful when removing three retaining screws to prevent injury to personnel or damage to equipment.

40. Remove spring return (87) as follows:
  - a. Remove two screws (88).
  - b. Position pin spanner (89) as shown.
  - c. Relieve tension against third screw (90) and remove screw.
  - d. Rotate spring return (87) counterclockwise until spring tension is relieved.
  - e. Remove spring return (87) from trunnion shaft (91).

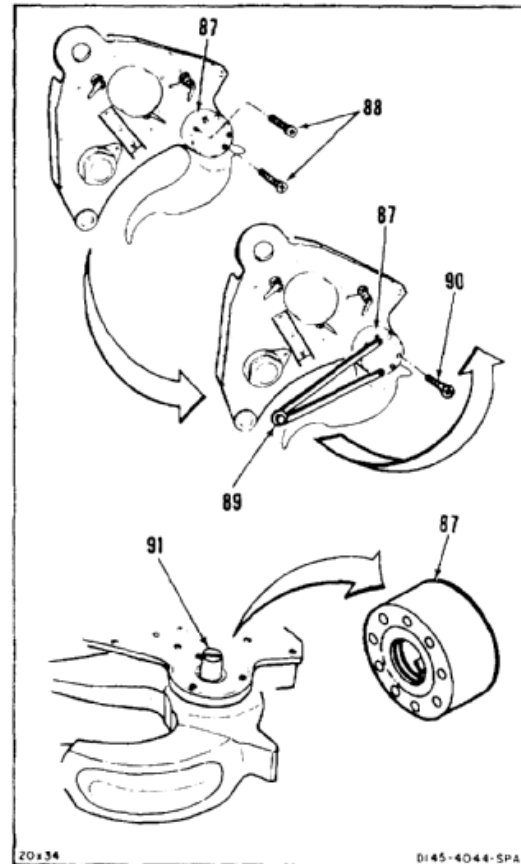

41. Rotate load beam (92) away from rear plate (66).
42. Remove retaining ring (93) and rear plate (66) from trunnion shaft (91).

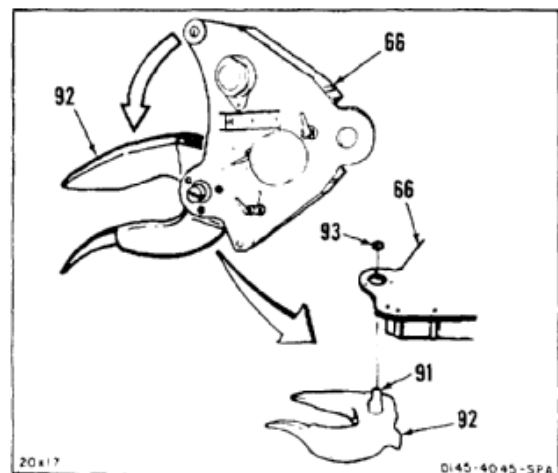

**WARNING**

Trunnion shaft contains spring loaded plunger. Be careful when removing springs and plunger, to prevent injury to personnel or damage to equipment.

43. Release springs (94 and 95) and plunger (96) as follows:
  - a. Position load beam (92) upright. Place several layers of cloth over trunnion shaft (91) and load beam (92). Use cloth (E120).
  - b. Tap one end of trunnion shaft (91) until plunger (96) and two springs (94 and 95) are released. Use soft faced hammer. Remove cloths after plunger is released.
44. Remove trunnion shaft (91) from load beam (92). Remove springs (94 and 95) and plunger (96) from trunnion shaft (91).
- 44.1. Inspect bearing surfaces of trunnion shaft (91) and load beam (92). There shall be no cracks, nicks, or gouges. Insert trunnion shaft in load beam. There shall be no binding.

**INSPECT**

- 44.2. Measure outside diameter of trunnion shaft (91) at two places (96.1). Diameter shall not be less than **0.991 inch**.
- 44.3. Measure distance from tip of load beam (92) to farthest flat of trunnion shaft bore (96.2). Distance shall not be less than **7.219 inches**.
- 44.4. Inspect tip (96.3) of load beam (92). Tip shall not be scraped or gouged.
45. Remove dust cover (97) from rear case (66).
46. Remove sealant from hole (98). Use hand held No. 30 drill bit.
47. Remove pin (99) from hole (98). Use **1/8 inch** pin punch. Drive pin from outer side of rear plate (66).

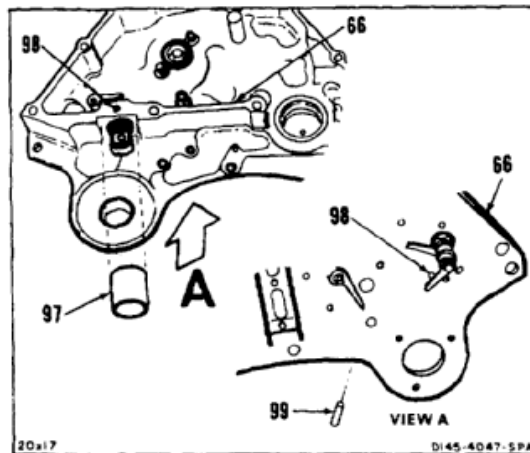
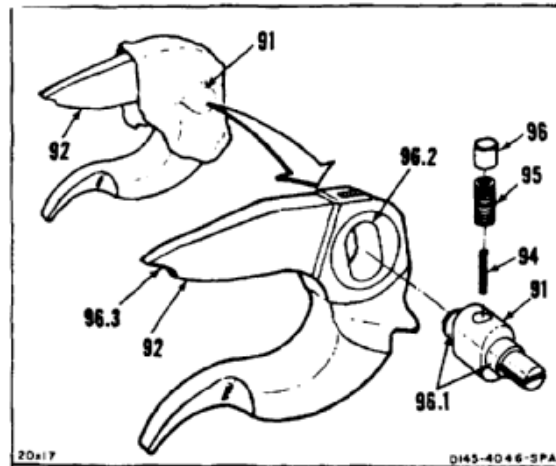



- 48. Remove plunger (100) and bushing (101) from rear plate (66).
- 48.1. Turn bearing (102) at end of plunger (100). Wheel shall turn smoothly, with no sticking or binding.
- 49. If bearing (102) sticks or binds, remove cotter pin (103), washer (104), clevis pin (105), and bearing (102) from plunger (100).

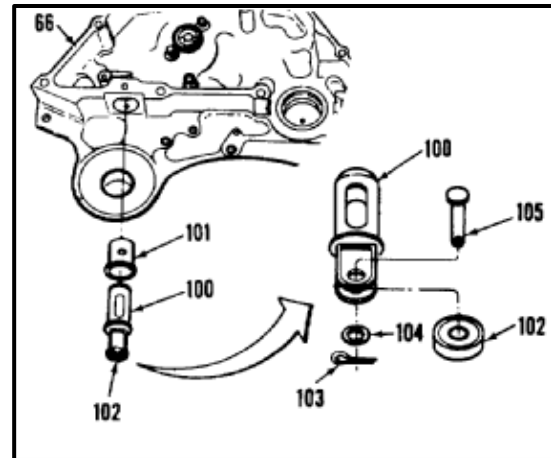

- 50. Remove two nuts (106), washers (107), and packings (108). Do not remove solenoid (109) at this time.

**CAUTION**

Solenoid and spring adjustment plate must not separate. Solenoid spring tension setting will be destroyed if separation occurs.

- 51. Separate plate (110) from gasket (111). Use knife.
- 52. Remove solenoid (109) with spring adjustment plate (110).
- 53. Remove gasket (111) from shaft support (112).

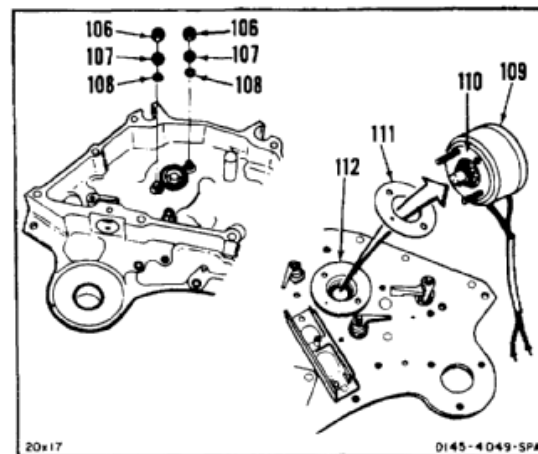

- 54. Remove shaft support (112). Tap out support from inside rear plate (66). Use soft faced hammer.
- 55. Remove retainer (113) and seal (114) from shaft support (112).
- 56. Remove gasket (115).

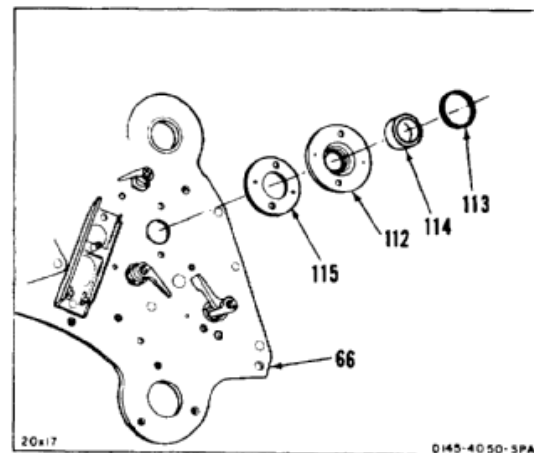

- 57. Remove lockwire, pin (116), and arm (117) and washer (117.1) if installed. Remove shaft (118) from rear plate (66). Remove packing (119) from shaft. Tag (E264) arm and shaft together.
- 58. Remove lockwire, pin (120), and arm (121) and washer (117.1) if installed. Remove shaft (122) from rear plate (66). Remove packing (119) from shaft. Tag (E264) arm and shaft together.
- 59. Remove lockwire, pin (123), and arm (124) and washer (117.1) if installed. Remove shaft (125) from rear plate (66). Remove packing (119) from shaft. Tag (E264) arm and shaft together.
- 59.1. Inspect shafts (118, 122, and 125). Shafts shall not be bent. No straightening is allowed.

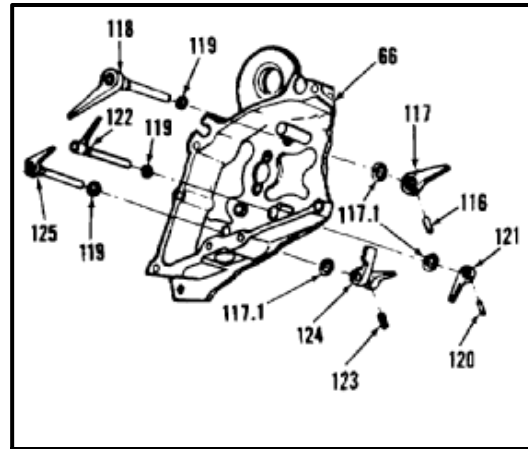

- 60. Remove three nuts (126) and washers (127) from inserts (128). Remove inserts from rear plate (66).
- 61. Remove packings (129) from inserts (128).

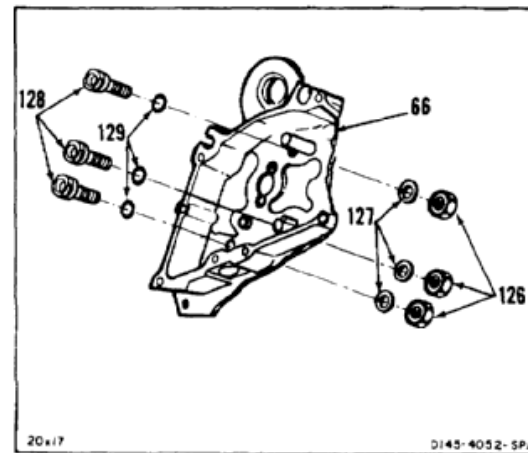

- 62. Remove two caps (130), one from front plate (65), one from rear plate (66). Use crowsfoot attachment.

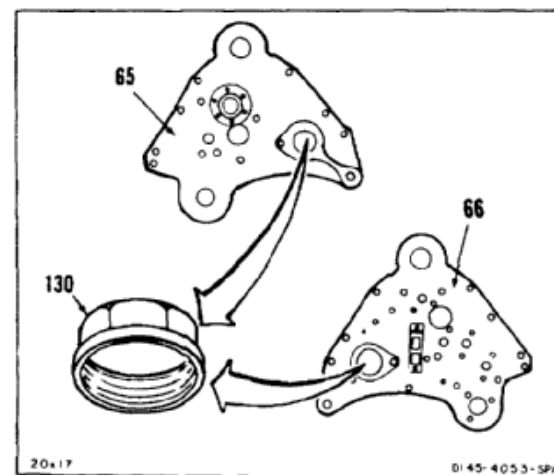

**NOTE**

Remove bushings only if worn.

63. Measure inside diameter of four bushings (131 thru 134), at two places **90°** apart. Average diameter shall not exceed the following:
  - a. Bushing (131) - **1.131 inches**.
  - b. Bushing (132) - **0.439 inch**.
  - c. Bushing (133) - **1.504 inches**.
  - d. Bushing (134) - **1.003 inches**.
64. Remove four bushings (131 thru 134) as needed from rear plate (66). Use arbor press.
65. Remove stop pin (135) and retainer pin (136) from rear plate (66).

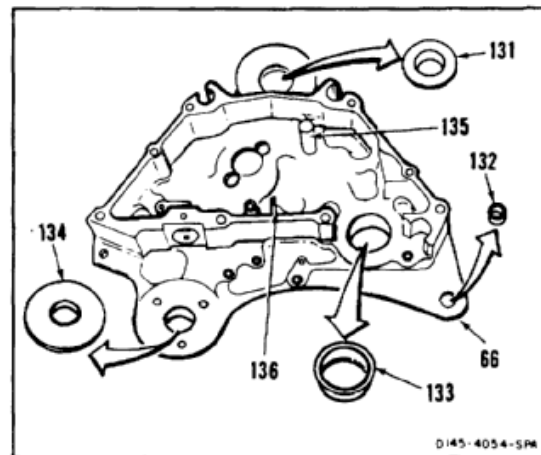

**INSPECT**

66. Measure inside diameter of four bushings (137 thru 140) at two places **90°** apart. Average diameter shall not exceed the following:
  - a. Bushing (137) - **1.068 inches**.
  - b. Bushing (138) - **1.003 inches**.
  - c. Bushing (139) - **0.439 inch**.
  - d. Bushing (140) - **1.504 inches**.

**NOTE**

Remove bushings only if worn.

67. Remove four bushings (137 thru 140) from front plate (65). Use arbor press.
68. Inspect six rivets (141). Rivets shall not be loose or cracked.

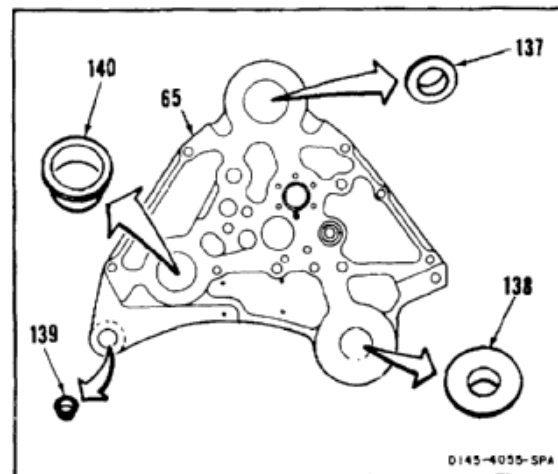

**NOTE**

Remove rivets only if loose or cracked.

69. Turn front plate (65) over and remove six rivets (141) as needed from shaft support (142). Use No. 40 drill.
70. Remove shaft support (142) from front plate (65).

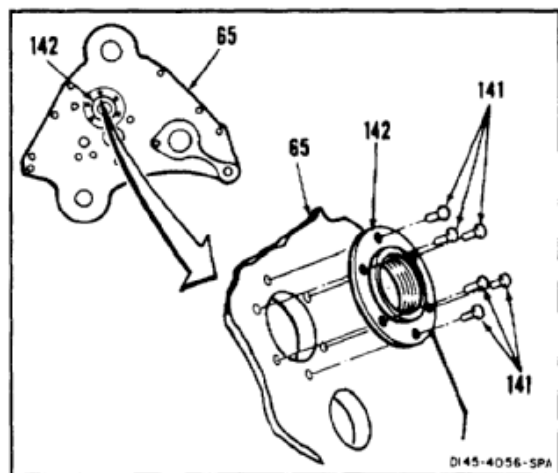

**FOLLOW-ON MAINTENANCE:**

None

END OF TASK

INITIAL SETUP

**Applicable Configurations:**

All

**Tools:**

Machine Shop Set, NSN 4920-00-405-9279

**Materials:**

None

**Personnel Required:**

Machinist

**Equipment Condition:**

Off Helicopter Task  
 Forward or Aft Cargo Hook Disassembled (Task 16-24)

**General Safety Instructions:**

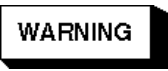

Use eye protection when drilling inserts and breaking keys.

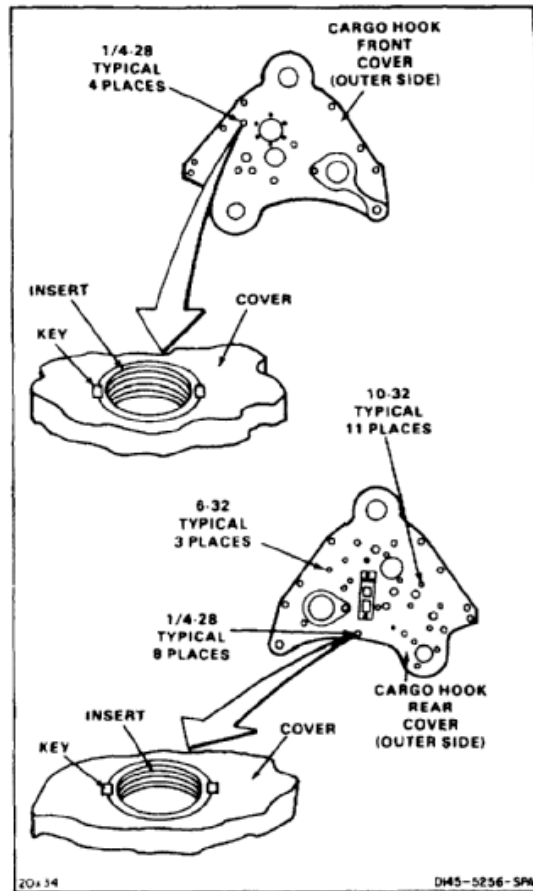

**NOTE**

Procedure is same for removal of threaded inserts from front or rear cover.

1. Position cover (1 or 2) outside up.

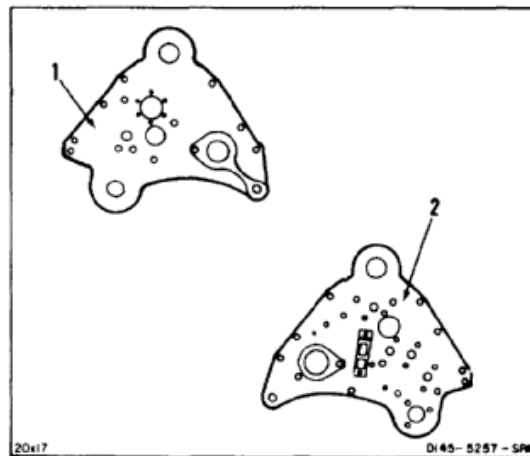

**16-25 REMOVE FORWARD OR AFT CARGO HOOK THREADED INSERTS (AVIM) (Continued) 16-25**

- Drill center of faulty insert (3). Use drill bit (4) listed. Drill to depth listed. Use drill press.

Insert Size	Drill Bit size	Depth
6-32	No. 21 in.	3/32 in.
10-32	7/32 in.	5/32 in.
1/4-28	9/32 in.	3/16 in.

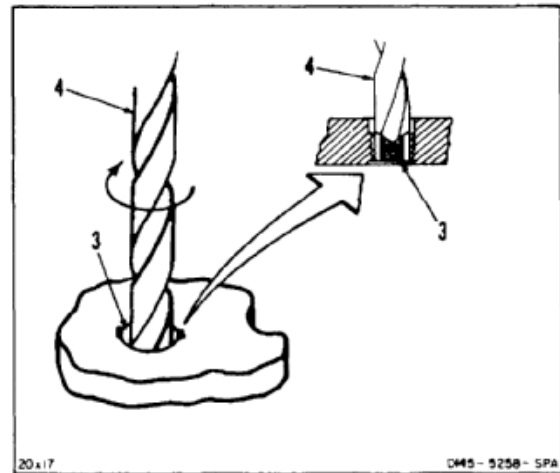

- Bend keys (5) inward. Use drift pin (6).
- Break off keys (5). Use drift pin (6).

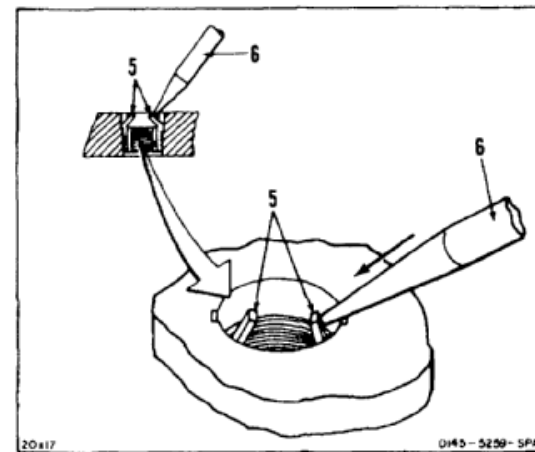

- Remove insert (3). Use screw extractor (7). Turn counterclockwise.

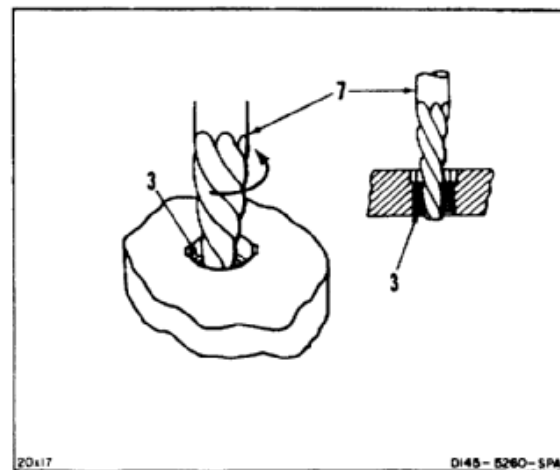

**FOLLOW-ON MAINTENANCE:**

None

END OF TASK

INITIAL SETUP

**Applicable Configurations:**

All

**Tools:**

- Machine Shop Set, NSN 4920-00-405-9279
- Insert Installation Tool, TD428L
- Insert Installation Tool, TD1032L
- Insert Installation Tool, TKNC06
- Source of Low Pressure Compressed Air

**Materials:**

- Brush (E86)
- Cloths (E120)
- Dry Cleaning Solvent (E162)
- Gloves (E184.1)
- Sealant (E335)
- Tongue Depressor (E424)
- Epoxy Primer (E292)

**Parts:**

Inserts

**Personnel Required:**

Machinist  
Inspector

**General Safety Instructions:**

**WARNING**

Dry cleaning solvent (E162) is flammable and toxic. It can irritate skin and cause burns. Use only in well-ventilated area, away from heat and open flame. In case of contact, immediately flush skin or eyes with water for at least **15 minutes**. Get medical attention for eyes.

**WARNING**

Sealant (E335) is toxic and can cause dermatitis. In case of contact, immediately flush skin or eyes with water for at least **15 minutes**. Get medical attention for eyes.

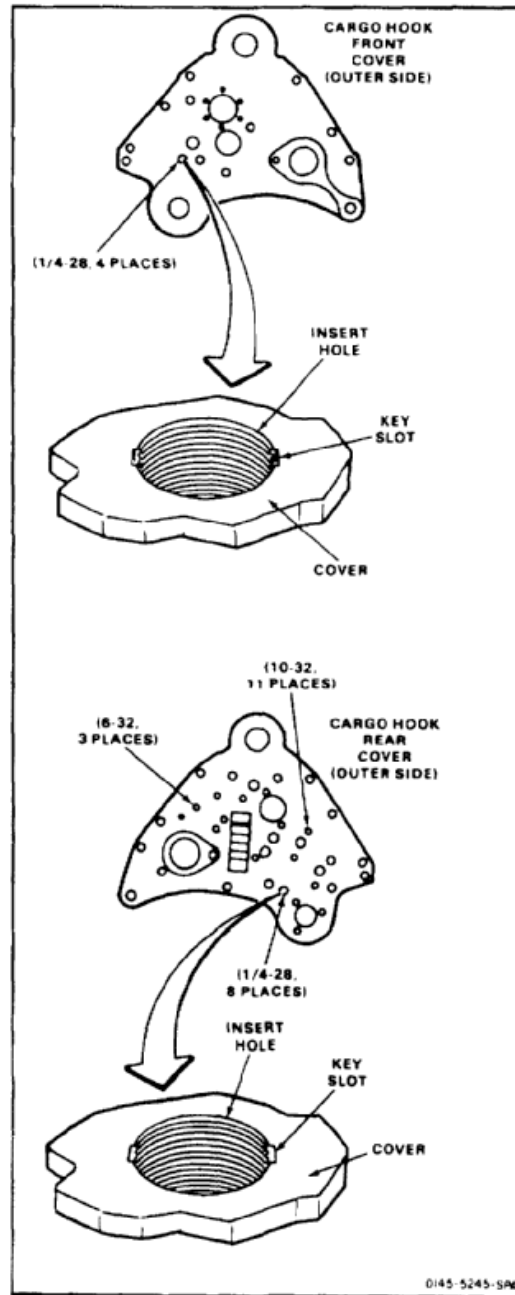

**NOTE**

Procedure is not same to install inserts in front or rear cover. If **1/4-28** insert in front cover is to be installed, go to step 1. If **10-32** or **1/4-28** insert in rear cover is to be installed, go to step 10. If **6-32** insert in rear cover is to be installed, go to step 22.

**INSTALL 1/4-28 INSERT IN FRONT COVER**

1. Clean any debris from hole (1) in front cover (2). Use dry cleaning solvent (E162) and low pressure air. Wear gloves (E184.1) and goggles.

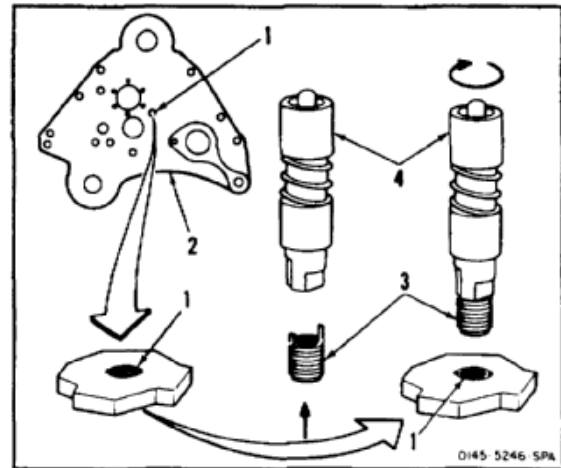
**WARNING**

Epoxy primer (E292) is flammable and toxic. It can irritate skin and cause burns. Use only with adequate ventilation, away from heat or open flame. Avoid contact with skin, eyes, or clothing. In case of contact, immediately flush skin or eyes with water for at least **15 minutes**. Get medical attention for eyes.

2. Coat hole (1) with epoxy primer (E292). Use brush (E86). Wear gloves (E184.1).
3. Position insert (3) on tool TD428L (4).
4. Install insert (3) in hole (1) while primer is wet.
5. Remove tool (4) from insert (3). Turn tool over, **180°** and set over protruding keys (5) of insert.
6. Drive down keys (5). Use arbor press or hammer.
7. Remove tool (4).

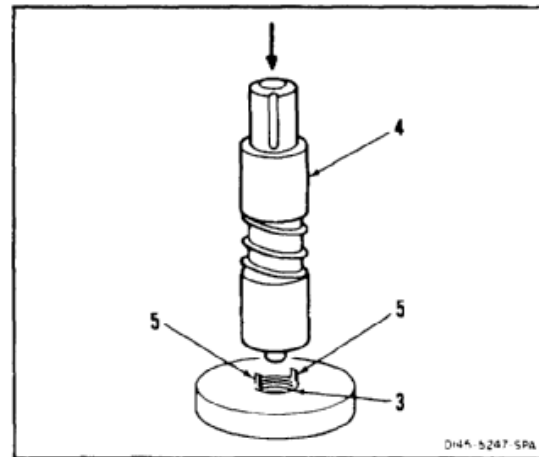

8. Remove excess primer from around insert hole (1) at both inside and outside of front cover (2). Use cloth (E120) moist with dry cleaning solvent (E162). Wear gloves (E184.1) and goggles.
9. Check insert (3) and keys (5). Insert and keys shall be flush to **0.010 inch** below outside surface of front cover (2).

**INSPECT**

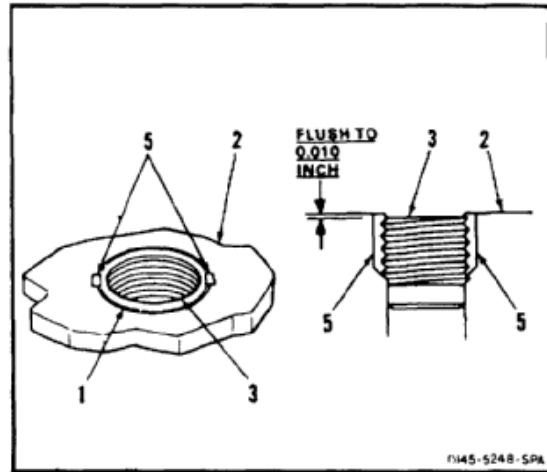

**INSTALL 10-32 OR 1/4-28 INSERT IN REAR COVER**

10. If insert hole (6) in rear cover (7) has sealant inside rear cover, scrape sealant away.
11. Clean any debris from inside and around insert hole (6) at both inside and outside rear cover (7). Use dry cleaning solvent (E162) and low pressure compressed air. Wear gloves (E184.1) and goggles.

**NOTE**

Avoid violent agitation of sealant mix, it reduces working time of sealant.

Do not fill threaded portion of insert with sealant.

12. Coat insert hole (6). Use sealant (E335) and brush (E86). Wear gloves (E184.1).
13. Select insert tool (8) as follows:

INSERT SIZE	TOOL NO.
10-32	TD1032L
1/4-28	TD428L

14. Position insert (9) on tool (8).
15. Install insert (9) in hole (6) while sealant is wet.

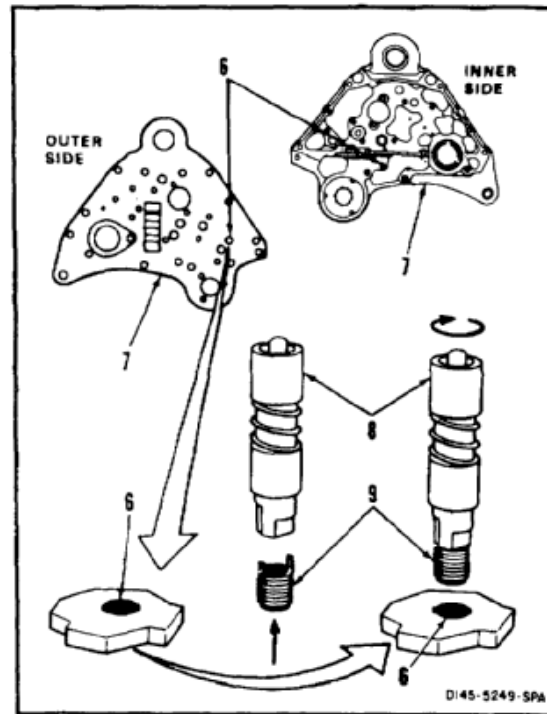



**16-26 INSTALL FORWARD OR AFT CARGO HOOK THREADED INSERTS (AVIM) (Continued) 16-26**

16. Remove tool (8) from insert (9). Turn tool over, **180°** and set over protruding keys (10) of insert.
17. Drive down keys (10). Use arbor press or hammer.
18. Remove tool (8).

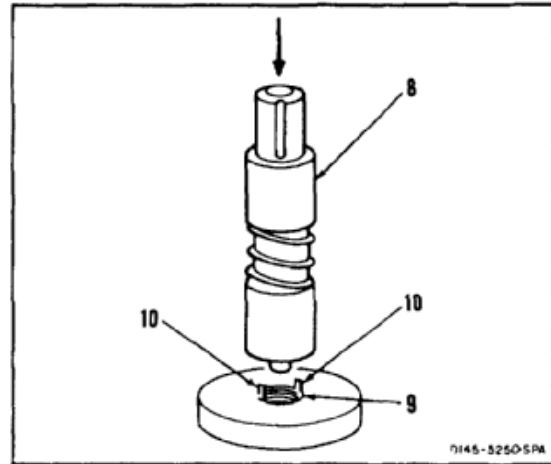

19. Remove excess sealant from around insert hole (6) at both inside and outside of rear cover (7). Use cloth (E120), moist with dry cleaning solvent (E162). Wear gloves (E184.1) and goggles.
20. Check insert (9) and keys (10). Insert and keys shall be flush to **0.010 inch** below outside surface of rear cover (7).

**INSPECT**

21. When **10-32** insert is installed, go to step 31.

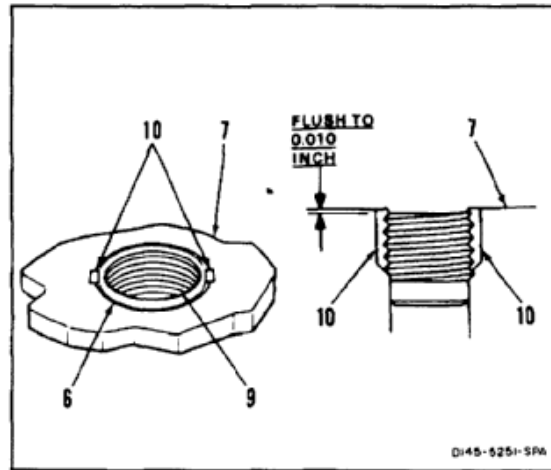

**INSTALL 6-32 INSERT IN REAR COVER**

22. If insert hole (11) in rear cover (7) has sealant inside rear cover, scrape sealant away.
23. Clean any debris from inside and around insert hole (11) at both inside and outside rear cover (7). Use dry cleaning solvent (E162) and low pressure compressed air. Wear gloves (E184.1) and goggles.
24. Coat insert hole (11). Use sealant (E335) and brush (E86). Wear gloves (E184.1).
25. Install insert (12) on tool TKNC06 (13).
26. Install insert (12) in rear cover (7) with tool (13) by rotating bottom of tool clockwise until insert seats in cover. Install insert while sealant is wet.

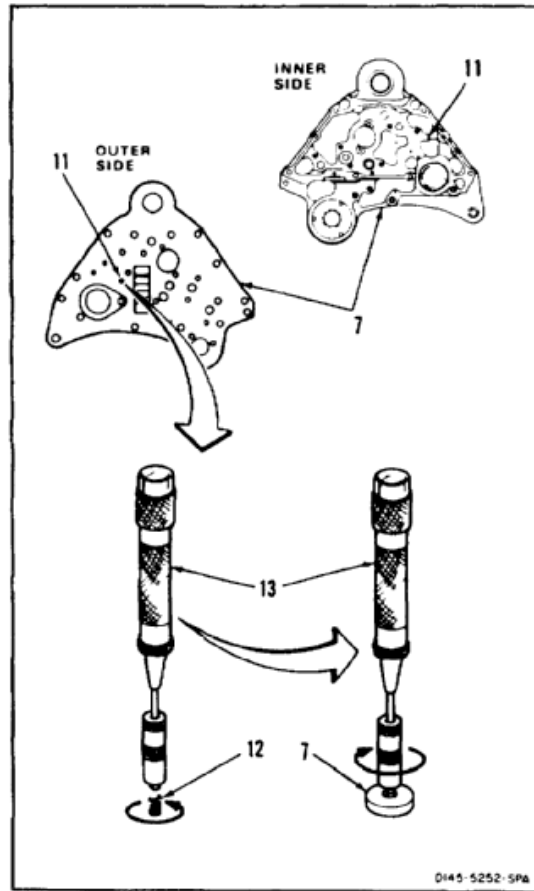

27. Depress handle of tool (13) and let spring-loaded mechanism drive down keys (15). Repeat as necessary to drive down keys.
28. Turn bottom of tool (13) counterclockwise and remove tool from insert (12).

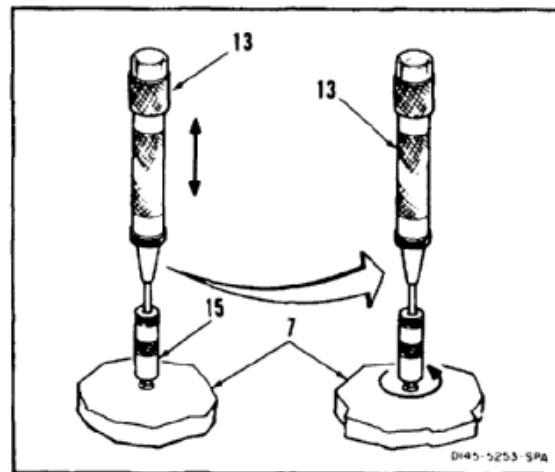

**16-26 INSTALL FORWARD OR AFT CARGO HOOK THREADED INSERTS (AVIM) (Continued)**

16-26

29. Remove excess sealant from around insert hole (11) at both inside and outside of rear cover (7). Use cloth (E120), moist with dry cleaning solvent (E162). Wear gloves (E184.1) and goggles.
30. Check insert (12) and keys (15). Insert and keys shall be flush to **0.010 inch** below outside surface of rear case (7).

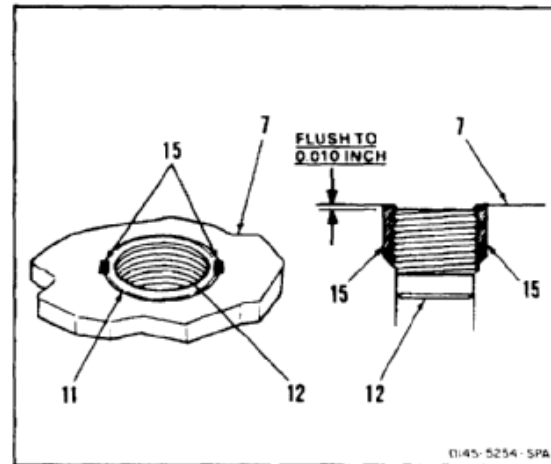
**INSPECT****SEAL 6-32 OR 10-32 INSERT IN REAR COVER****NOTE**

Avoid violent agitation of sealant mix. It reduces working time of sealant.

Do not fill threaded portion of insert with sealant.

Only inserts **6-32** or **10-32** are to be sealed.

31. Seal inner side of **6-32** inserts (16) or **10-32** inserts (17). Use sealant (E335). Wear gloves (E184.1).

**INSPECT****FOLLOW-ON MAINTENANCE:**

None

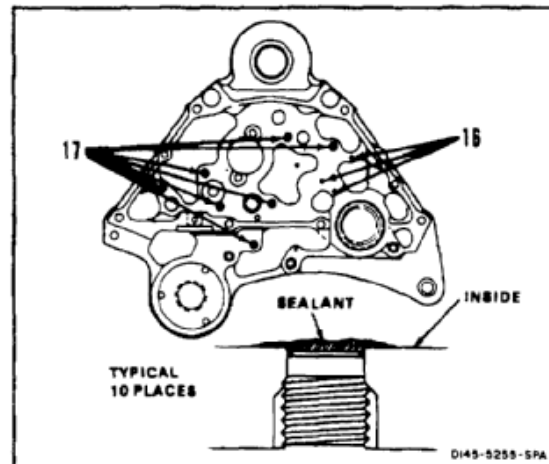

END OF TASK

## INITIAL SETUP

**Applicable Configurations:**

All

**Tools:**

Electrical Instrument Shop Set, NSN  
4920-00-165-1453  
Tool Crib Shop Set, NSN 4920-00-472-4183  
Sheet Metal Shop Set, NSN 4920-00-166-5505  
Aircraft Mechanic's Tool Kit, NSN 5180-00-323-4692  
Self Clinching Strap Hand Tool, NSN  
5120-00-781-7891  
Contact Insertion/Extraction Tool (M83723/31-16)  
Arbor Press  
Crowfoot Attachment, 1-15/16 Inch  
Brass, Round Stock, 1/8 Inch to 6 Inches  
Torque Wrench, 0 to 50 Inch-Pounds  
Torque Wrench, 30 to 150 Inch-Pounds

**Materials:**

Acetone (E20)  
Adhesive (E43)  
Adhesive, RTV108 (E57)  
Cloth (E120)  
Dry Film Lubricant (E238)  
Lubricant (E238.1)  
Gloves (E184.1)  
Grease (E190)  
Lockwire (E227 and E231)  
Epoxy Primer (E292)  
Sealant (E340.1)  
Loctite 404 (E343)  
Solvent (E413.4)

**Parts:**

Cotter Pins  
Gaskets  
Packings  
Retaining Rings  
Rivets  
Seals

**Personnel Required:**

Machinist  
Medium Helicopter Repairer  
Aircraft Electrician  
Inspector

**References:**

TM 55-1520-240-23P

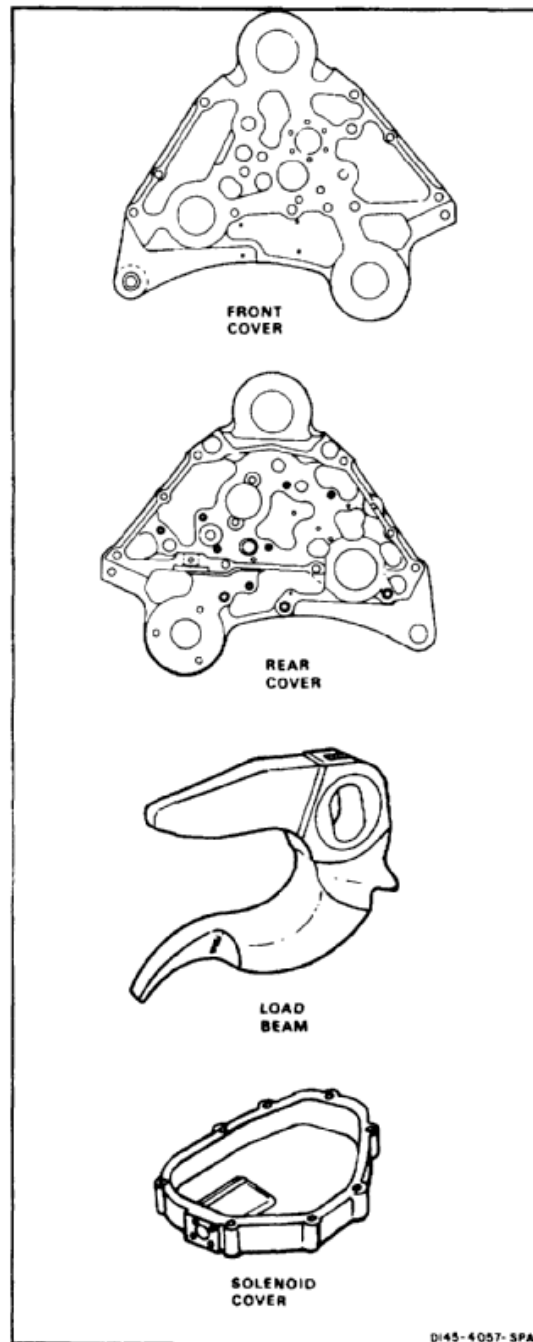

**General Safety Instructions:****WARNING**

Epoxy primer (E292) is flammable and toxic. It can irritate skin and cause burns. Use only with adequate ventilation, away from heat or open flame. Avoid contact with skin, eyes, or clothing. In case of contact, immediately flush skin or eyes with water for at least **15 minutes**. Get medical attention for eyes.

**WARNING**

Sealant (E340.1) and adhesive (E57) can irritate skin and cause burns. Avoid contact with skin, eyes, or clothing. In case of contact, immediately flush skin or eyes with water for at least **15 minutes**. Get medical attention for eyes.

**WARNING**

Acetone (E20) is extremely flammable. It can be toxic. Avoid inhaling. Use only with adequate ventilation. Avoid contact with skin, eyes, or clothing. Keep away from heat, sparks, or open flame. In case of contact, immediately flush skin or eyes with water for at least **15 minutes**. Get medical attention for eyes.

**WARNING**

Solvent (E413.4) is flammable and toxic. It can irritate skin and cause burns. Avoid inhaling. Use only with adequate ventilation. Avoid contact with skin, eyes, or clothing. Keep away from heat, sparks, or open flame. In case of contact immediately flush skin or eyes with water for at least **15 minutes**. Get medical attention for eyes.

**WARNING**

Loctite 404 (E343) is combustible and toxic. It can irritate skin and cause burns, use only with adequate ventilation, away from open flame. In case of contact, immediately flush skin or eyes with water for at least **15 minutes**. Get medical attention for eyes.

**NOTE**

All mating surfaces must be clean before assembly. Use solvent (E413.4) to clean Teflon bearings. Use acetone (E20) to clean other components. Use cloths (E120). Wear gloves (E184.1).

1. Coat mount surface of front plate support hole (1) with primer (E292). Wear gloves (E184.1).
2. Align holes of shaft support (2) and front plate (3). Press shaft support in front plate while primer is wet. Use arbor press.
3. Install six rivets (4).
  
4. Coat mount surface of three bushing holes (5), pin boss hole (6), and latch bearing hole (7), with primer (E292). Wear gloves (E184.1).
5. Press in three bushings (8, 9, 10), pin boss (11), and latch bearing (12) while primer is wet. Use arbor press.

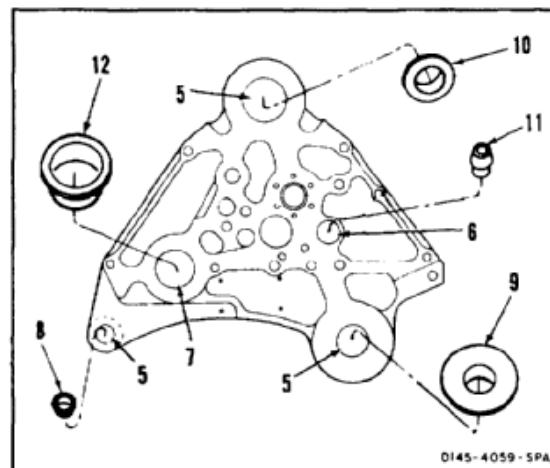
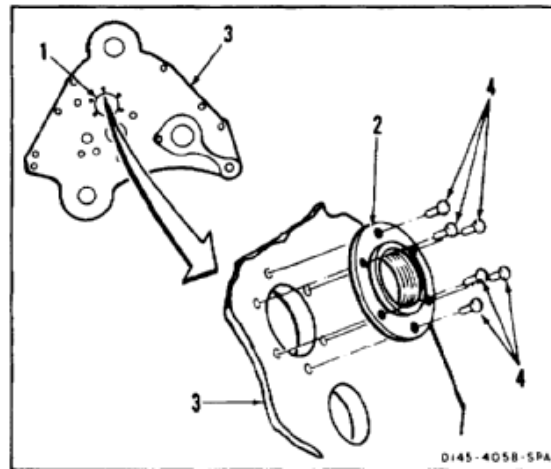

6. Coat mount surface of three bushing holes (13) and two pin mount holes (14) with primer (E292). Wear gloves (E184.1).
7. Press in three bushings (15, 16, 17), stop pin (18), and retainer pin (19). Use arbor press.

**WARNING**

Adhesive (E43) is toxic. It can irritate skin and cause burns. Avoid inhaling. Use only with adequate ventilation. Avoid contact with skin, eyes, or clothing. In case of contact immediately flush skin or eyes with water for at least **15 minutes**. Get medical attention for eyes.

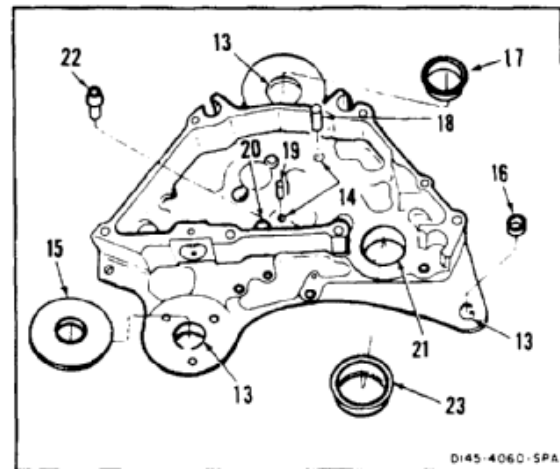

8. Coat mount surface of pin boss holes (20) and latch bearing hole (21) with adhesive (E43).
9. Install pin boss (22) and latch bearing (23). Use arbor press.
10. Coat threads of caps (24) with Loctite (E343). Wear gloves (E184.1). Install two caps (24), one on front cover plate (3) over latch bearing (12), and one on rear plate (25) over latch bearing (23). Use crowfoot attachment.
11. Install three packings (26, 27, 28) on inserts (29, 30, 31). Install inserts in rear plate (25).
12. Install three washers (32, 33, 34) and nuts (35, 36, 37). Torque nuts to **120 inch-pounds**.
13. Apply grease to inside of three inserts (29, 30, 31). Use grease (E190).

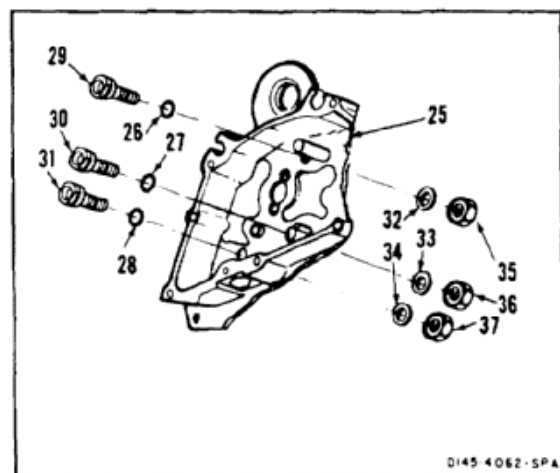
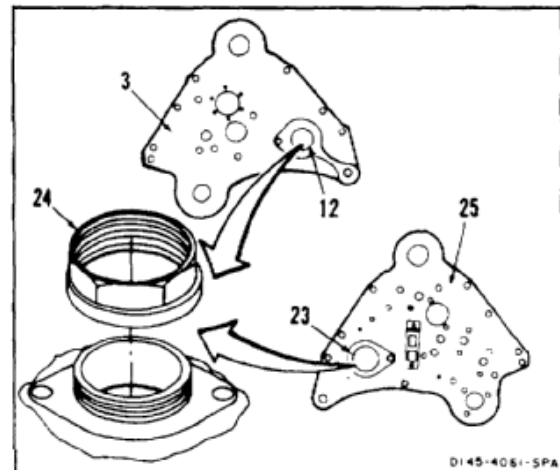

14. Remove tag and install packing (36) on shaft (39). Install shaft in insert (29).
15. Install arm (40) on shaft (39). Install pin (41) in arm and shim with washers (41.1) as required to remove end play. Lockwire pin. Use lockwire (E227).
16. Remove tag and install packing (42) on shaft (43). Install shaft in insert (30).
17. Install arm (44) on shaft (43). Install pin (45) in arm and shim with washers (41.1) as required to remove end play. Lockwire pin. Use lockwire (E227).
18. Remove tag and install packing (46) on shaft (47). Install shaft in insert (31).
19. Install arm (48) on shaft (47). Install pin (49) in arm and shim with washers (41.1) as required to remove end play. Lockwire pin. Use lockwire (E227).
20. Apply lubricant (E238.1) to OD of seal (50). Wear gloves (E184.1). Install seal and retainer ring (51) in shaft support (52).

**WARNING**

Lubricant (E238.1) is toxic. It can irritate skin and cause burns. Avoid inhaling. Use only with adequate ventilation. Avoid contact with skin, eyes, or clothing. In case of contact immediately flush skin or eyes with water for at least **15 minutes**. Get medical attention for eyes.

21. Deleted.
22. Apply sealant (E340.1) to support (52) inside surface and seal (50). Position gasket (53) and install shaft support (52) in rear plate (25). Use arbor press. Wear gloves (E184.1).
23. Install gasket (54) on solenoid (55). Position solenoid in shaft support (52), rotate rear plate (25) and solenoid (55) **180°**.
24. Apply sealant (E340.1) to plate (25), around solenoid shaft (58), and studs (56.1), and to both sides of two packings (57). Install packings on studs. Wear gloves (E184.1).
25. Install washers (58) and nuts (59) on solenoid (55). Torque nuts to **72 inch-pounds**.

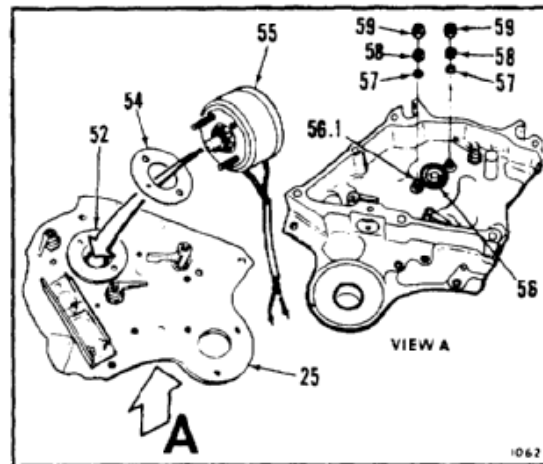
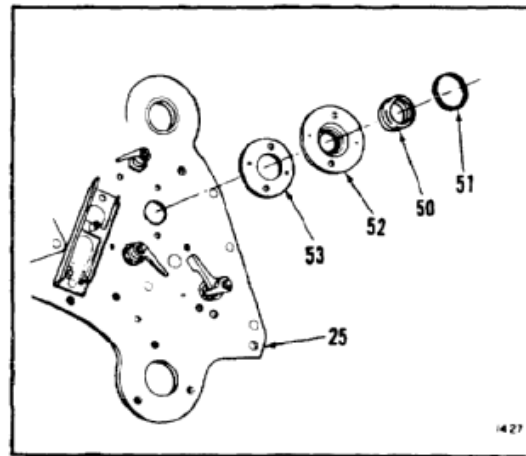
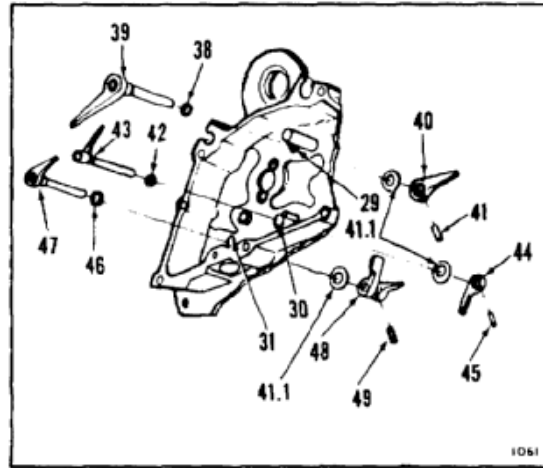



26. Position bearings (60) in plunger (61). Install clevis pin (62), washer (63), and cotter pin (64). Check that bearing rotates freely, with no binding.
27. Install bushing (65), plunger (61), and pin (66) in rear plate (25). Seal hole (67) with adhesive (E57). Wear gloves (E184.1).
28. Install dust cover (68) over plunger (61) and bushing (65). Apply Loctite 404 (E343) around edge of dust cover. Wear gloves (E184.1).

**WARNING**

Be careful when compressing trunnion springs to prevent injury to personnel or damage to equipment.

29. Install springs (69 and 70) and plunger (71) in trunnion shaft (72) as follows:
  - a. Apply grease to springs (69 and 70) and plunger (71). Use grease (E190).
  - b. Install springs (69 and 70) and plunger (71) in trunnion shaft (72).
  - c. Install trunnion shaft (72) in vise (73), slotted end of shaft up and vise on half of plunger (71) as shown.
  - d. Compress springs (69 and 70) and plunger (71) into trunnion shaft (72) with vise (73).

**WARNING**

Trunnion shaft contains spring loaded plunger. Be careful when placing load beam over trunnion shaft and releasing spring tension to prevent injury to personnel or damage to equipment.

30. Position load beam (74) over trunnion shaft (72). Make sure load beam (74) covers exposed part of plunger (71).
31. Hold load beam (74) in position and release trunnion shaft (72) from vise (73).
32. Position load beam (74) upright. Tap trunnion shaft (72) into load beam. Use soft faced hammer.

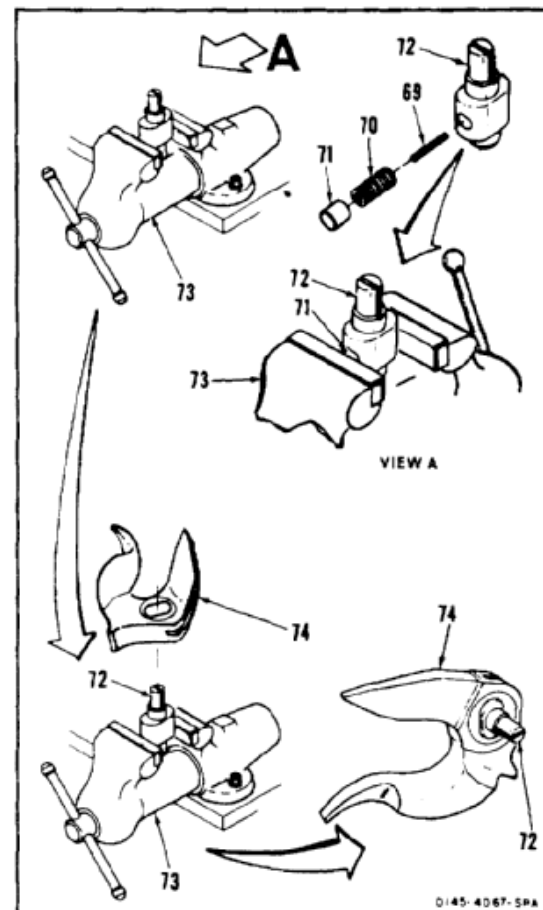
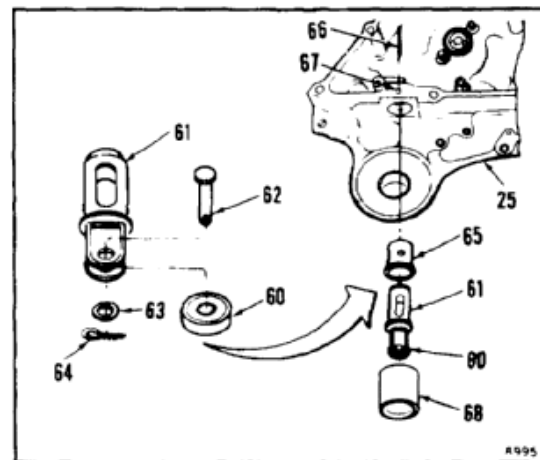

33. Position load beam (74) on its side, slotted end of trunnion shaft (72) up.
34. Install rear plate (25) over trunnion shaft (72) with opening in load beam (74) away from rear plate.
35. Install retaining ring (75).
36. Rotate load beam (74) up to rear plate (25).

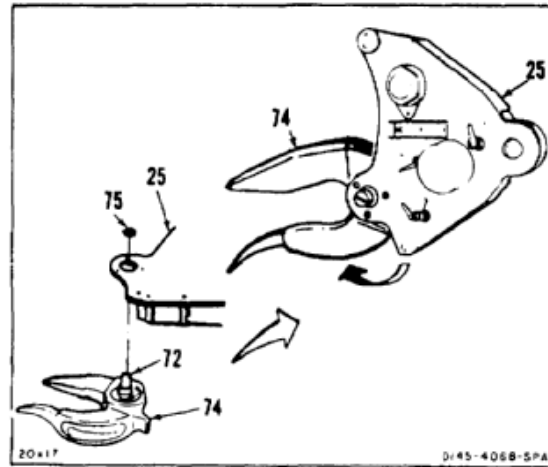

37. Align spring (76) with slot in trunnion shaft (72) and install spring return (77) on shaft.
38. Set spring return (77) tension as follows:
  - a. Mark screw hole (78) at point A.
  - b. Using adjustable pin spanner, rotate spring return (77) clockwise to point B.

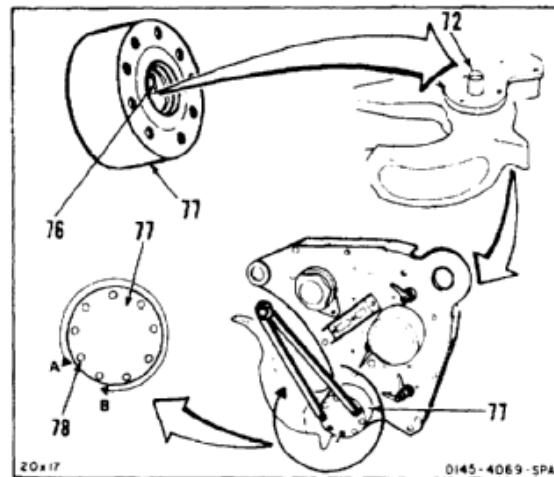

39. Install three screws (79). Torque screws to **13 inch-pounds**.

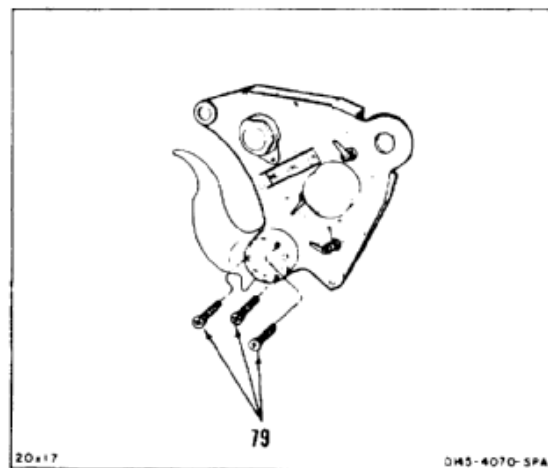

40. Rotate rear plate (25) and load beam (74) over **180°**. Make sure load beam (74) stays on trunnion shaft (72).
41. Install shaft (80) in latch (81). Install two bearings (82), washers (83), and nuts (84) on shaft. Install two cotter pins (85) on nuts.
42. Position springs (86) on latch (81) and install pin (87). Lockwire pin. Use lockwire (E227).
43. Install latch (81) in rear plate (25).
44. Install spring (86) over retainer pin (14). Position spring in groove of pin.

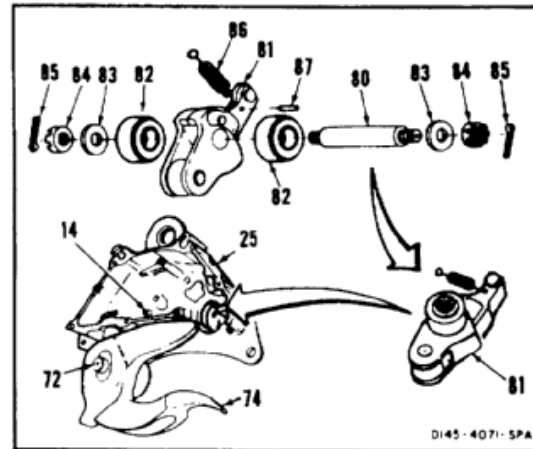

45. Position shaft (88) over lever (89) with link (90) in center of lever.
46. Position spring (91) over link (90). Depress spring and install clevis pin (92).

**WARNING**

Lubricant (E238) is toxic. It can irritate skin and cause burns. Avoid inhaling. Use only with adequate ventilation. Avoid contact with skin, eyes, or clothing. In case of contact immediately flush skin or eyes with water for at least **15 minutes**. Get medical attention for eyes.

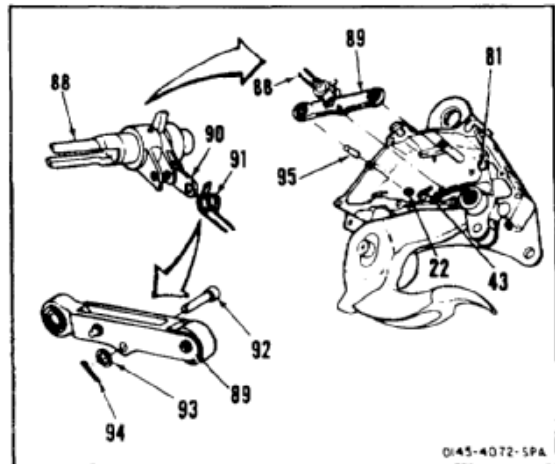

47. Install washer (93) and cotter pin (94). Spray shaft (88) and lever (89) with lubricant (E238). Wear gloves (E184.1).
48. Install pivot pin (95) in pin boss (22).
49. Hold latch (81) away from center of rear plate (25) and install shaft (88) and lever (89). Make sure actuator shaft arm (43) is above head of clevis pin (92).

- 50. Install latch bumper (96). Position bumper so that latch (81) will strike area of bumper not previously contacted.
- 51. Install two bumpers (97).
- 52. Install two fitting bumpers (98) in fitting (99). Install fitting in rear plate (25), raised shoulder forward.

**INSPECT**

- 53. Coat mating surfaces of front plate (3) and rear plate (25) with adhesive (E57). Wear gloves (E184.1).



Do not force or hammer plates to seal plates together. Damage to plates can result.

- 54. Position front plate (3) on rear plate (25).

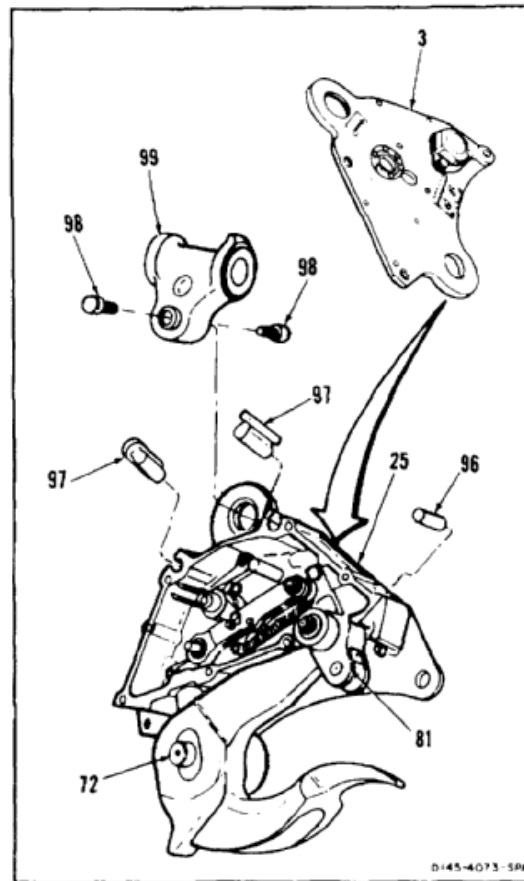

- 55. Apply primer (E292) under bolt heads (100, 101, and 102), on washers (103), and under nuts (104). Wear gloves (E184.1).
- 56. Install four short bolts (100), bolt (101), and washers (103), while primer is wet. Install long bolt (101) and washer (103) in hole closest to cap (24), while primer is wet.
- 57. Hold two plates (3 and 25) together and rotate **180°**. Install washers (103) and nuts (104) on four bolts (100), while primer is wet.
- 58. Apply sealant (E340.1) to two packings (105) both sides. Install packings, two washers (102), and two nuts (104) on bolts (101 and 102) while primer is wet. Wear gloves (E184.1). Torque nuts to **120 inch-pounds**.

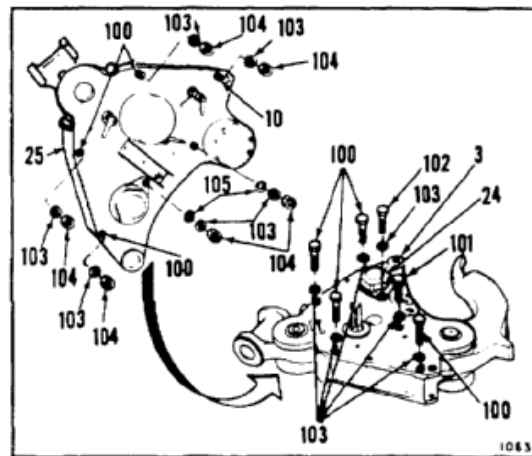

- 59. Remove tag, and install switch (107), two screws (108), four washers (109), and two nuts (110) on bracket (111). Center adjustment slot (112) of switch (107) on bracket (111).
- 60. Install bracket (111), two screws (113), and washers (114) on rear plate (25). Torque screws to **13 inch-pounds**.
- 61. Lockwire screws (113) together. Use lockwire (E227).
- 62. Remove tags, and install three switches (115), six screws (116), and washers (117) rear plate (25). Center adjustment slots (118) of switches.

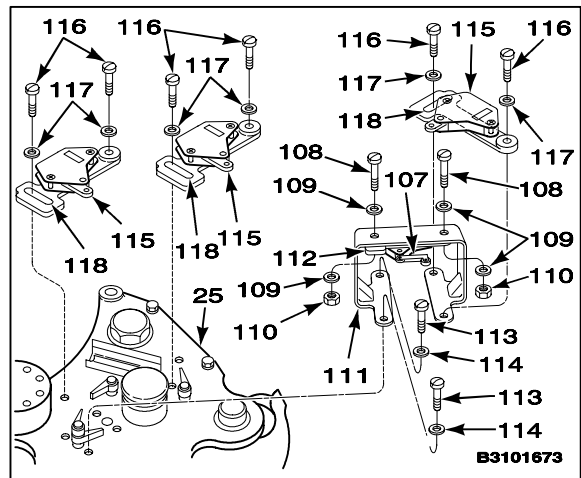

- 63. Position relay (119) and ground wire (120) on rear plate (25). Install three screws (121) and washers (122). Torque screws to **9 inch-pounds**. Lockwire screws. Use lockwire (E227).
- 64. Remove tags and install six modules (123). Tighten lock screw (124).
- 65. Connect wires (125) from switches (107) and (115), relay (119), solenoid (55), and ground wire (120) to modules (123). Use contact insertion/extraction tool.

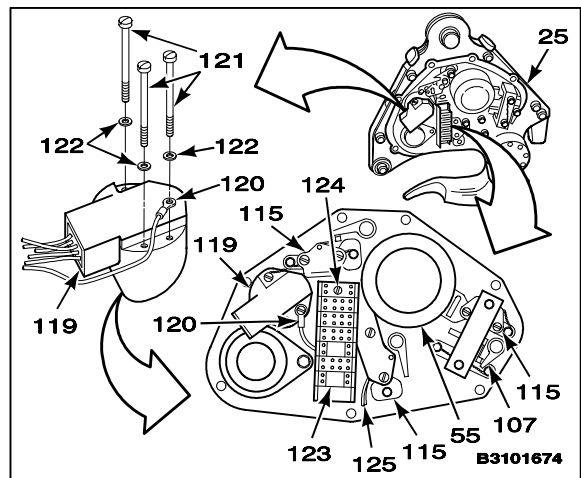

- 66. Position gasket (126) on harness (127). Install harness with wires pointing towards top of hook. Install four screws (128) and washers (129) in cover (130). Torque screws **8-10 inch-pounds**. Lockwire screws. Use lockwire (E227).
- 66.1. Apply sealant (E340.1) around harness (127) where it comes through cover (130). Wear gloves (E184.1).

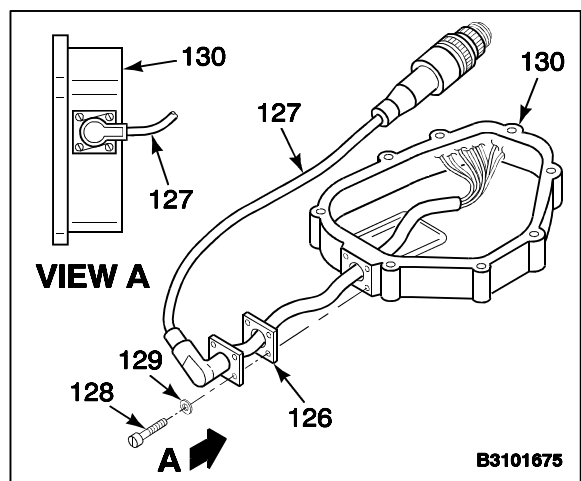

- 67. Position gasket (131) on rear plate (25).
- 68. Connect harness wires (132) to modules (123). Use insertion/extraction tool.
- 69. Route wire harness (127) below modules (123) and install three straps (133). Use strap tool.

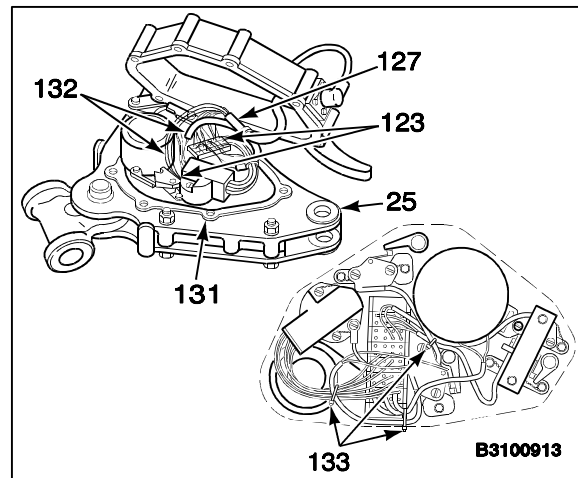

- 70. Position solenoid cover (130) on rear plate (25) and install seven bolts (134), bolt (134.1), and washers (135). Torque bolts to **35 inch-pounds**.
- 70.1. Install packing (135.1), washer (135.2), and bolt (135.3) in solenoid cover (130). Torque bolt (135.3) to **50 inch-pounds**. Lockwire bolt (134.1) to bolt (135.3). Use lockwire (E231).

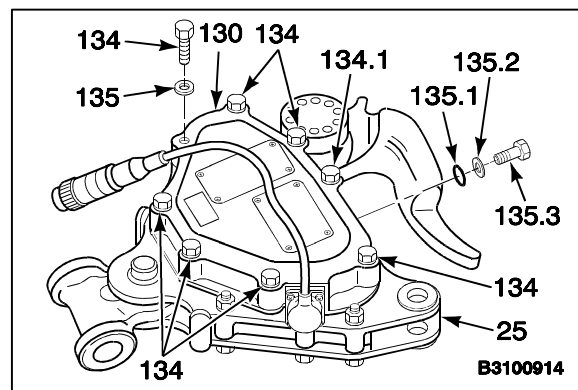

- 71. Position spring (136) in keeper (137) and install bushing (138).
- 72. Position keeper (137) between front plate (3) and rear plate (25), use cotter pin extractor (139) to depress spring (136) into position, as keeper is installed.
- 73. Install bolt (140), two washers (141), nut (142), and cotter pin (143).
- 74. Install bumper (144). Bumper should be fit tight. Install bolt (145), two washers (146), nut (147), and cotter pin (148).

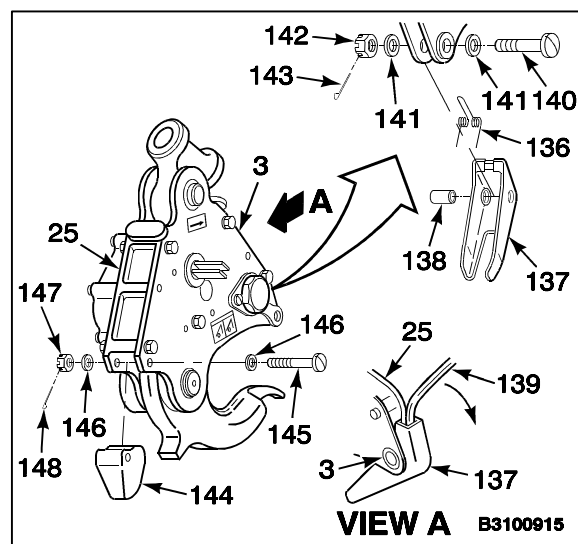

- 75. Install seal (149), spring facing out, and retaining ring (150).
- 76. Align holes of retainer plug (151) and knob retainer (152) and install plug. Seal plug end of retainer with adhesive (E57). Wear gloves (E184.1).
- 77. Install retainer (152) in cover (153).

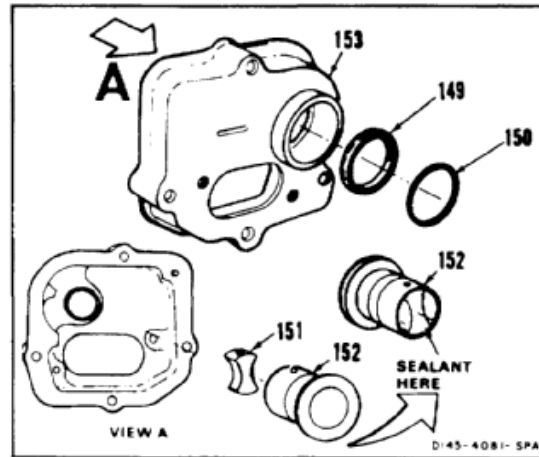

- 78. Apply adhesive (E57) inside knob (154). Align holes of knob and retainer (152). Install knob on retainer. Wear gloves (E184.1).
- 79. Fill roll pin (155) with adhesive (E57). Install roll pin in knob (154) and retainer plug (152). Center roll pin in knob. Wear gloves (E184.1).

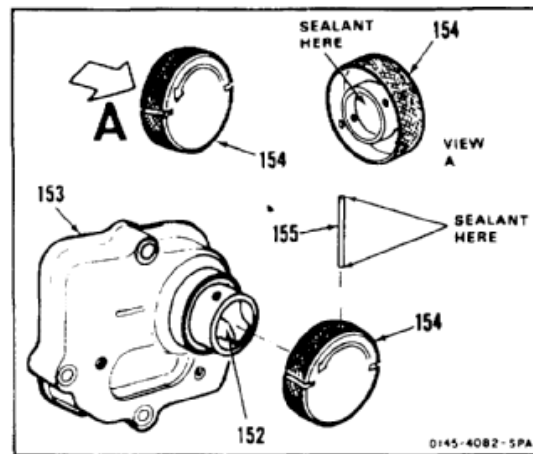

- 80. Install cable adapter (156) in cover (153).
- 81. Position spring (157) and install pin (158) in arm (159).
- 82. Position arm (159) and spring (157) in cover (153). Install pin (160).

**INSPECT**

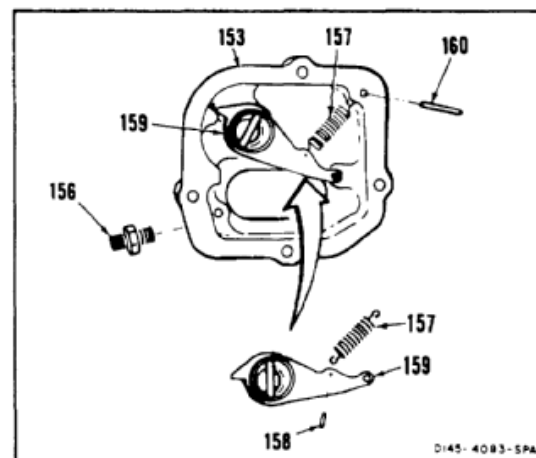

83. Apply light coat of sealant (E340.1) to mating surface of cover (153). Wear gloves (E184.1).
84. Position cover (153) with arrow (162) on knob (154) at top, on front cover (3).
85. Install four screws (163). Torque screws to **35 inch-pounds** .
86. Position window (164) and install two screws (165) and two washers (166).

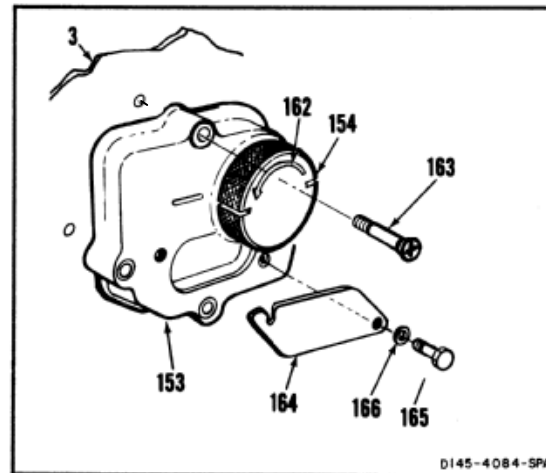
**INSPECT****FOLLOW-ON MAINTENANCE:**

- Adjust external cargo hook switches (Task 16-28).
- Perform functional test of external cargo hook (Task 16-29).

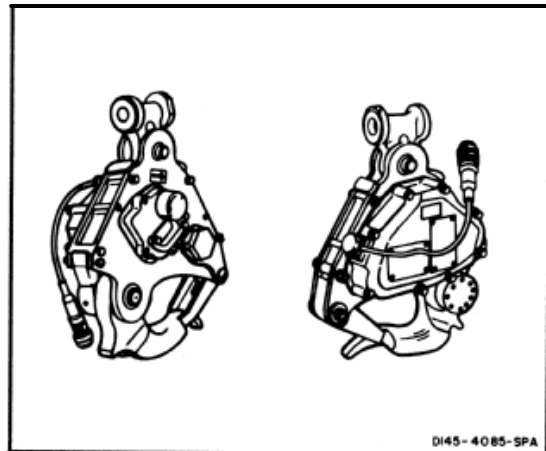

END OF TASK



## INITIAL SETUP

**Applicable Configurations:**

All

**Tools:**

Electrical Repairer's Tool Kit, NSN 5180-00-323-4915  
 Work Hoist, Minimum 300 Pound Capacity  
 Bolt, 3/4 Inch X 6 Inch  
 Wire Rope Ring (APP E-18)  
 Weight, 250 Pound  
 DC Power Supply, 0 to 50 Volts  
 Multimeter  
 Torque Wrench, 5 to 50 Inch-Pounds  
 Torque Wrench, 30 to 150 Inch-Pounds  
 Drill Bit, 5/64 Inch

**Adjustment Setup:**

Momentary Switch, MS25089-1A  
 Contact Pins, M39029/1-14-16  
 Wire, M22759/16-20-9

**Materials:**

Lockwire (E227)  
 Lockwire (E231)  
 Tongue Depressor (E424)  
 Twine (E433)

**Personnel Required:**

Aircraft Electrician  
 Inspector

**References:**

Appendix E

**Equipment Condition:**

Off Helicopter Task  
 Adjustment Setup

**General Safety Instructions:****WARNING**

Stand clear of hook and load when raising or lowering to prevent injury to personnel.

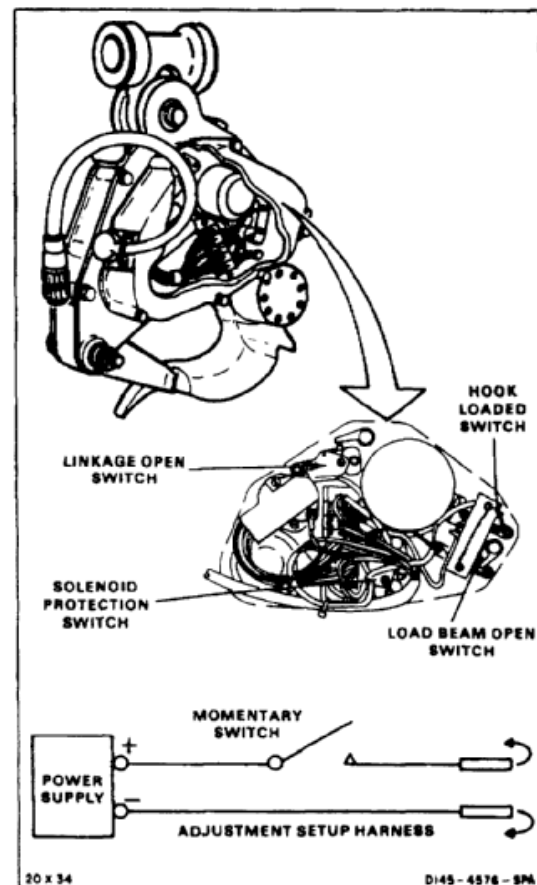

1. Attach hoist (1) and wire rope ring (2) to hook (3).
2. Remove eight bolts (4) and washers (5) from solenoid cover (6).
3. Move solenoid cover (6) to gain access to switches (7). Support cover in open position by tying cover to keeper (8). Use twine (E433).

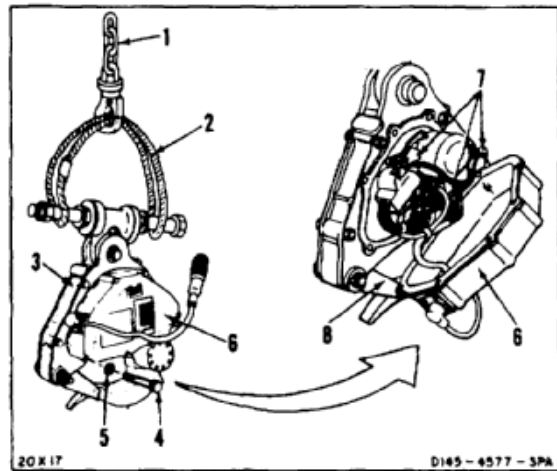

4. On opposite side of hook (3) remove two bolts (9) and washers (10). Remove inspection window (11).
5. Route lockwire (12) through cable adaptor (13). Fasten lockwire to arm (14). Use lockwire (E231).

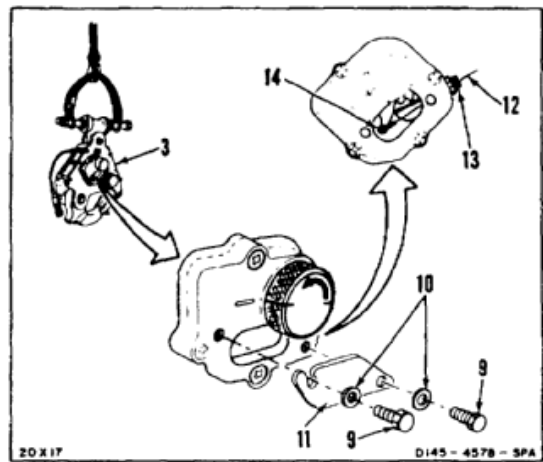

**LINKAGE OPEN SWITCH ADJUSTMENT**

6. Check load beam (15). Make sure beam is closed and latched. Make sure index mark (16) on knob (17) is aligned with index mark (18).

7. Position tongue depressor (19) between load-beam-open switch (20) and actuator arm (21).

**NOTE**

Load-beam-open switch must be blocked during adjustment of linkage-open switch.

8. Connect multimeter (22) set to RX1 scale, between pins B and F of connector plug (23).
9. Pull lockwire (12) until gap between arm (24) and pin (25) is **5/64 inch**. Use **5/64 inch** drill bit. Maintain this distance.
10. Remove lockwire from screws (26) and loosen screws.
11. Move linkage-open switch (27) away from actuator arm (28) as far as it will go.
12. Move linkage-open switch (27) toward actuator arm (28) until multimeter (22) reads **0 ohm**. Tighten two screws (26).
13. Release lockwire (12). Check multimeter (22) reading. Multimeter shall read **infinity**.
14. Pull lockwire (12) until gap between arm (24) and pin (25) is **5/64 inch**. Check multimeter (22) reading. Multimeter shall read **0 ohm**. Release lockwire.
15. Rotate knob (17) counterclockwise until gap between arm (24) and pin (25) is **5/64 inch**. Check multimeter (22) reading. Multimeter shall read **0 ohm**.
16. Release knob (17). Check multimeter (22) reading. Multimeter shall read **infinity**.
17. Torque two screws (26) to **15 inch-pounds**. Lockwire screws. Use lockwire (E227). Remove tongue depressor (19).
18. Disconnect multimeter (22) from connector plug (23).

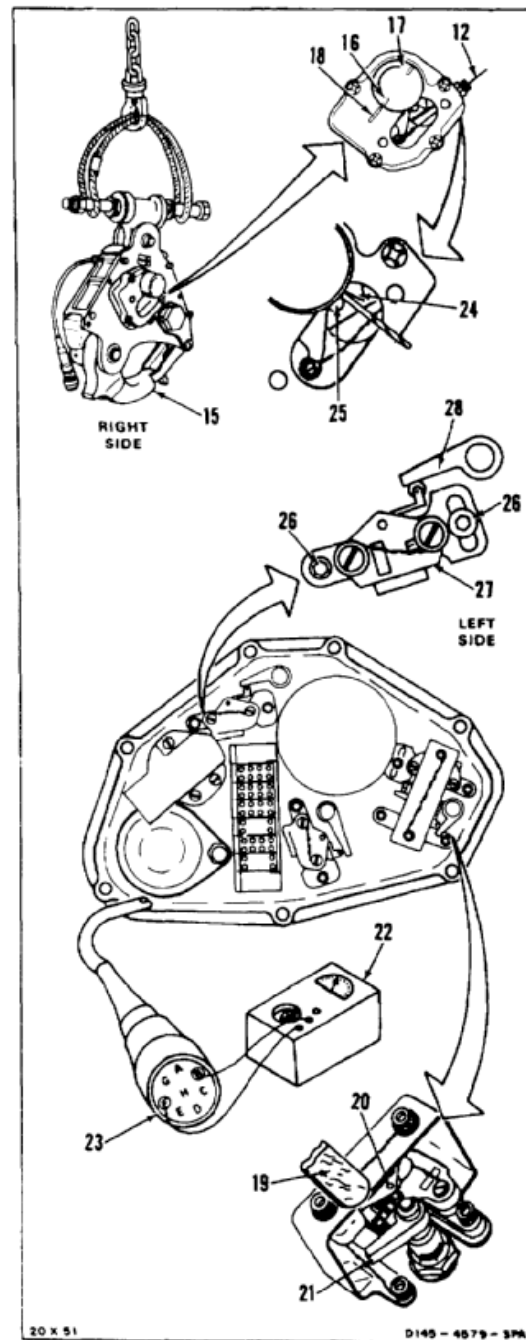

**LOAD-BEAM OPEN SWITCH ADJUSTMENT****WARNING**

Load-beam is spring loaded closed. Be careful when opening or closing load-beam, to prevent injury to personnel.

19. Rotate knob (17) counterclockwise. Rotate and hold load beam (15) open. Release knob. Reset latch (29) to closed position. Release load beam. Load beam shall rest on bottom of latch.
20. Connect multimeter (22), set to RX1 scale, between pins B and F of connector plug (23).
21. Remove lockwire and loosen two screws (30) and nuts (31).
22. Move load-beam-open switch (20) toward actuator arm (21) as far as it will go.
23. Move load-beam-open switch (20) away from actuator arm (21) until multimeter (22) reads **0 ohm**.
24. Tighten two screws (30) and nuts (31).
25. Rotate knob (17) counterclockwise. Load beam (15) shall return to closed and latched position. Release knob. Check multimeter (22) reading. Multimeter shall read **infinity**.
26. Rotate knob (17) counterclockwise. Rotate and hold load beam (15) open. Release knob. Reset latch (29) to closed position. Release load beam. Load beam shall rest on bottom of latch. Check multimeter (22) reading. Multimeter shall read **0 ohm**.
27. Rotate knob (17) counterclockwise. Load beam (15) shall return to closed and latched position. Release knob. Check multimeter (22) reading. Multimeter shall read **infinity**.
28. Torque screws (30) and nuts (31) to **15 inch-pounds**. Lockwire screws. Use lockwire (E227).
29. Disconnect multimeter (22) from connector plug (23).

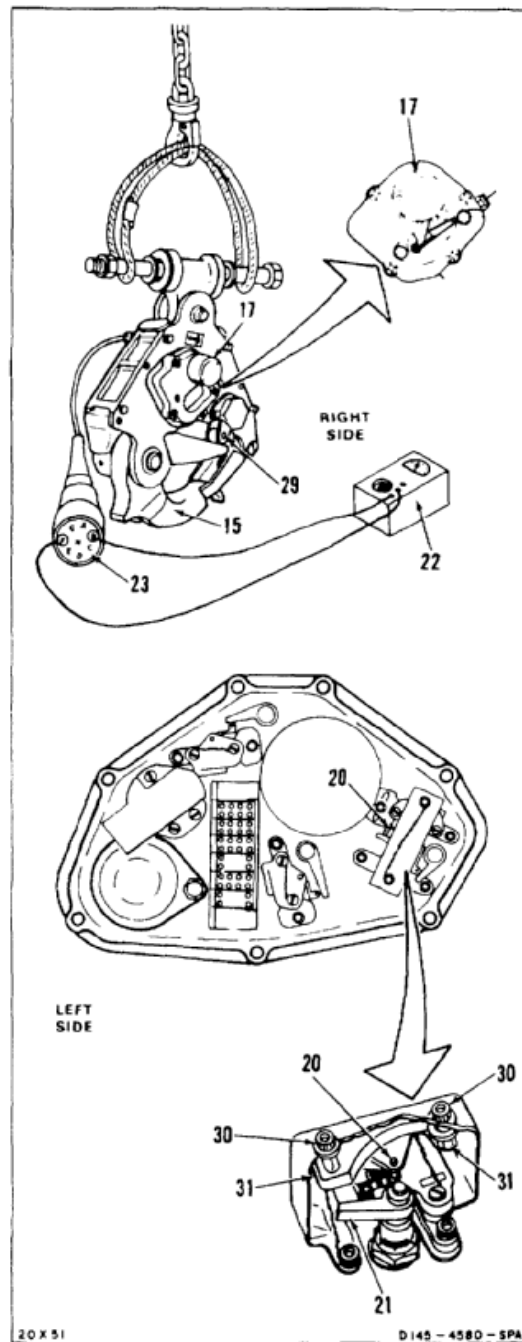

**HOOK-LOADED SWITCH ADJUSTMENT**

30. Connect multimeter (22) set to RX1 scale, between pins A and F of connector plug (23).
31. Remove lockwire and loosen two screws (32).
32. Move hook-loaded switch (33) toward actuator arm (34) as far as it will go.
33. Connect **250 pound** load (35) to load beam (15). Load shall be straight down and centered on beam.
34. Raise hoist (1) until load (35) clears ground.
35. Move hook-loaded switch (33) away from actuator arm (34) until multimeter reads **0 ohm**.
36. Tighten two screws (32).
37. Lower hoist (1). Remove **250 pound** load (35) from load beam (15). Check multimeter (22) reading. Multimeter shall read **infinity**.
38. Connect **250 pound** load (35) to load beam (15). Load shall be straight down and centered on beam.
39. Raise hoist (1) until load (35) clears ground. Check multimeter (22) reading. Multimeter shall read **0 ohm**.
40. Lower hoist (1). Remove **250 pound** load (35) from load beam (15).
41. Torque two screws (32) to **15 inch-pounds**. Lockwire screws. Use lockwire (E227).
42. Disconnect multimeter (22) from connector plug (23).

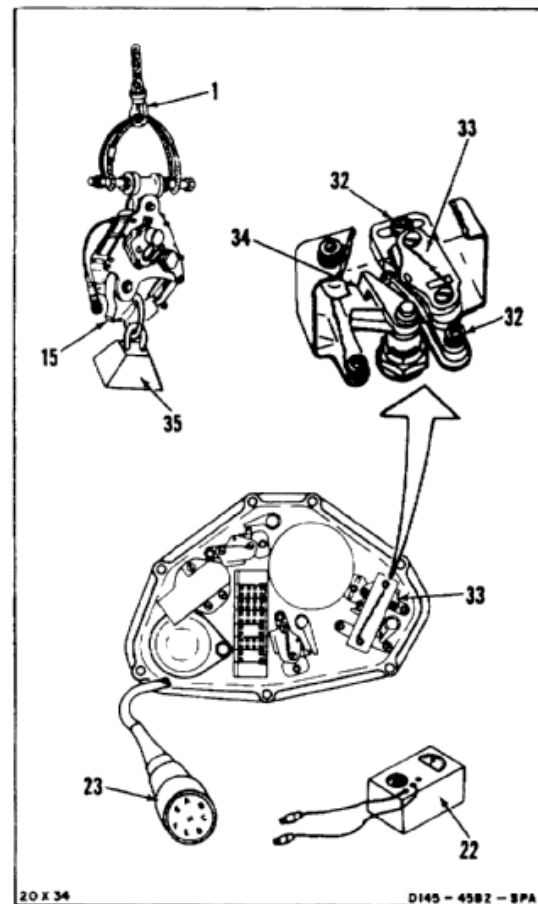
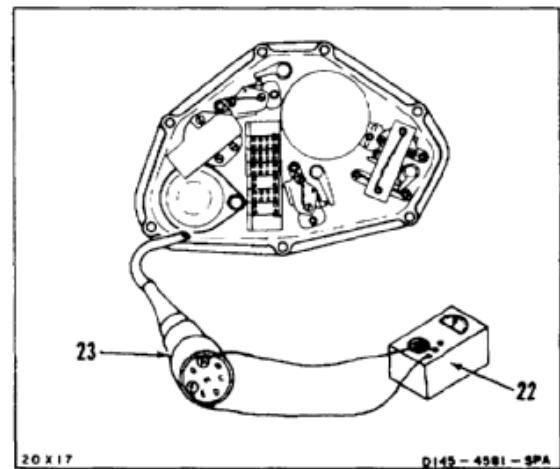

**SOLENOID-PROTECTION SWITCH ADJUSTMENT**

43. Make sure load beam (15) is closed and latched.
44. Connect multimeter (22) set to RX 10,000 scale, to pins C and D of connector plug (23).
45. Remove lockwire and loosen two screws (36). Move solenoid-protection switch (37) away from actuator arm (38) as far as it will go.
46. Rotate knob (17) counterclockwise until internal lever (39) is raised to highest point. Turn knob clockwise until internal lever descends **1/16 inch**. Maintain this distance.
47. Move solenoid-protection switch (37) toward actuator arm (38) until multimeter (22) reads **infinity**.
48. Tighten two screws (36).
49. Release knob (17). Internal lever (39) shall drop to latch position. Check multimeter (22) reading. Multimeter shall read **0 ohm**.
50. Rotate knob (17) counterclockwise until internal lever (39) is raised to highest point. Turn knob clockwise until internal lever descends **1/16 inch**. Check multimeter (22) reading. Multimeter shall read **infinity**.
51. Release knob (17).
52. Disconnect multimeter (22) from connector plug (23).
53. Connect adjustment setup harness (40) to connector plug (23) with positive test lead to pin C and negative lead to pin D.
54. Adjust power supply (41) to **22 volts**. Actuate switch (42). Check internal lever (39). Lever shall raise and drop rapidly.
55. Release switch (42).
56. Shut down power supply (41).
57. Remove adjustment setup harness (40) from connector plug (23).
58. Torque two screws (36) to **15 inch-pounds**. Lockwire screws. Use lockwire.

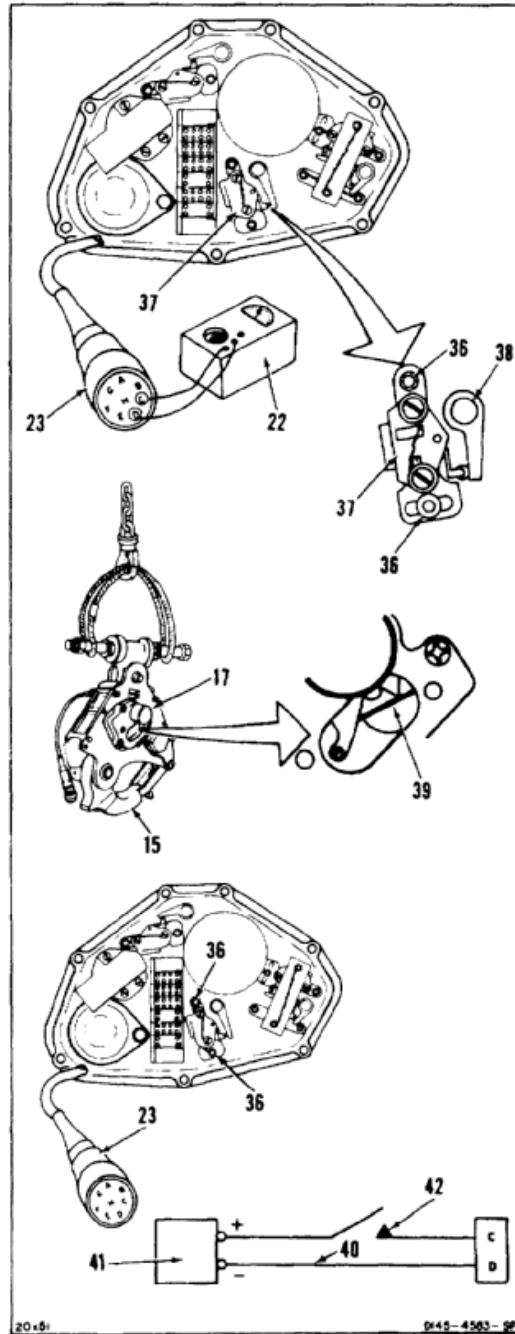

**16-28 ADJUST FORWARD OR AFT CARGO HOOK SWITCHES (AVIM) (Continued)**

16-28

59. Remove lockwire (12) routed through adaptor (13) to arm (14).
60. Position inspection window (11). Install two bolts (9) and washers (10).
61. Torque bolts (9) to **40 inch-pounds**.
62. Lockwire bolts (9) and cable adaptor (13) together. Use lockwire (E231).

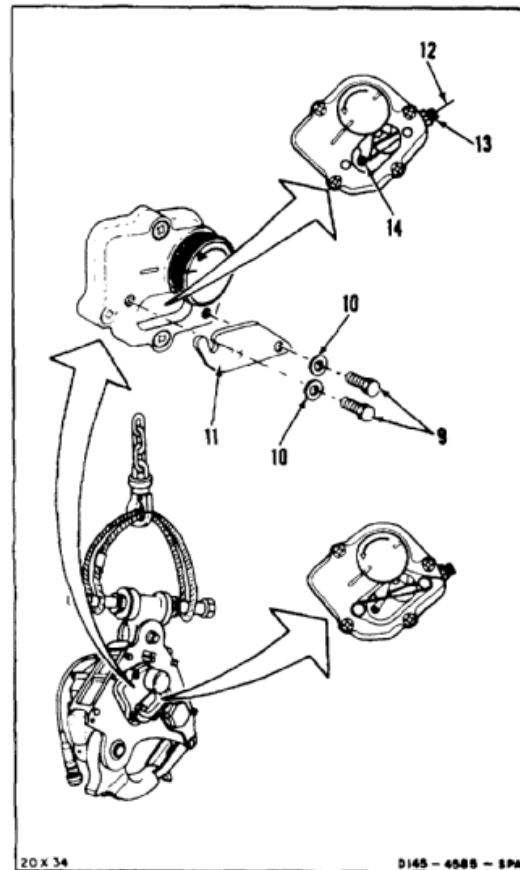

63. Remove twine used to support solenoid cover (6). Make sure gasket (43) is positioned.
64. Position solenoid cover (6). Install eight bolts (4) and washers (5). Torque bolts alternately, following torque sequence shown, to **60 inch-pounds**. Check torque again after torquing.
65. Lower hoist (1). Remove hook (3) and wire rope ring (2).

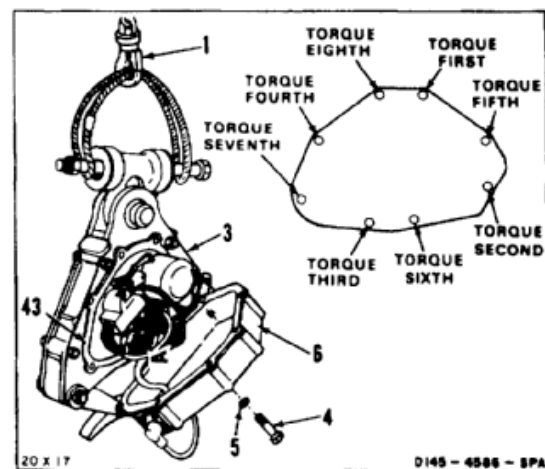
**FOLLOW-ON MAINTENANCE:**

- Pressure test solenoid cover (Task 16-30).
- Functional test external cargo hook (Task 16-29).

END OF TASK

## INITIAL SETUP

**Applicable Configurations:**

All

**Tools:**

Electrical Repairer's Tool Kit, NSN 5180-00-323-4915  
Hoist, Minimum 300 Pound Capacity  
Wire Rope Ring and Bolt Assembly (APP E-18)  
Weight, 20 Pound  
Weight, 80 Pound  
DC Power Supply, 0 to 50 Volts  
Multimeter  
Torque Wrench, 5 to 50 Inch-Pounds  
Scale, Dial Indicating, 0 to 50 Pounds  
Brass, Round Stock, 1/8 Inch X 6 Inches  
Momentary Switch, MS25089-1A  
Contact Pins, M39029/16-20-9  
Wire, M22759/16-20-9

**Materials:**

Lockwire (E231)

**Personnel Required:**

Medium Helicopter Repairer  
Aircraft Electrician  
Inspector

**References:**

Task 16-24  
Appendix E

**Equipment Condition:**

Off Helicopter Task  
Hook Switches Adjusted (Task 16-28)  
Test Setup

**General Safety Instructions:****WARNING**

Stand clear of hook and load when raising, lowering or releasing load to prevent injury to personnel.



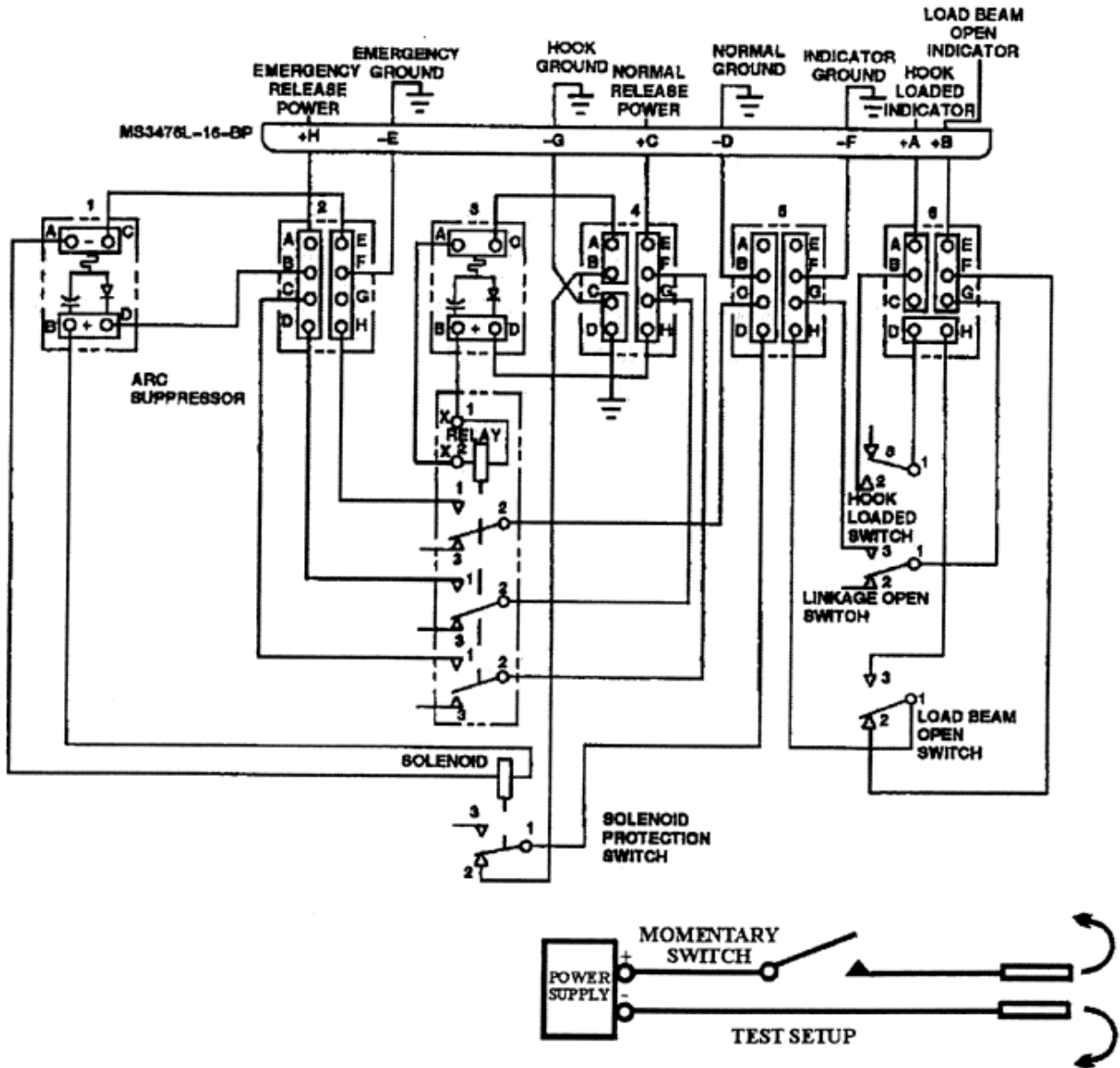

1. Attach hoist (1) and wire rope ring and bolt assembly (2) to hook (3).
2. Remove lockwire and two bolts (4) and washers (5). Remove inspection window (6).
3. Route lockwire (7) through cable adapter (8). Fasten lockwire to emergency release arm (9). Use lockwire (E231).

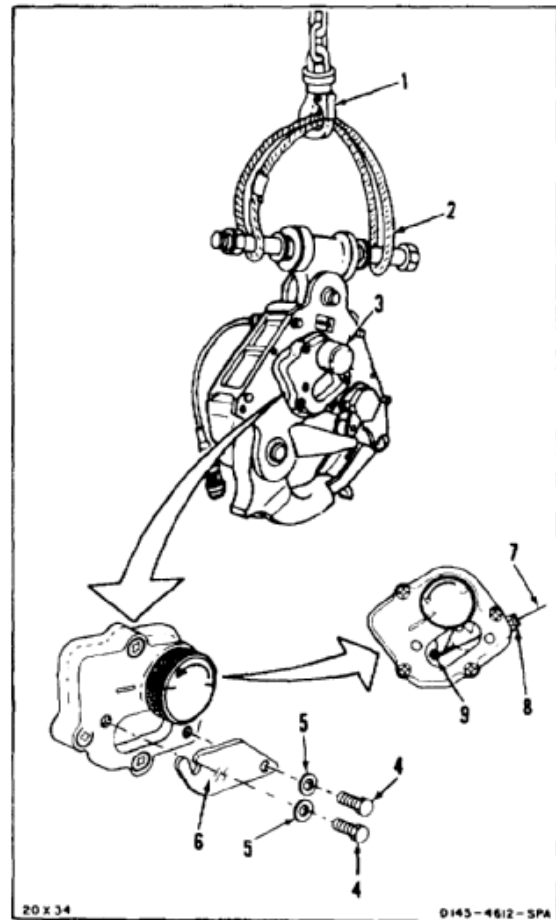

4. Connect **20-pound** load (10) to load beam (11). Load shall be straight down and centered on beam.
5. Raise hoist (1) until load (10) clears ground.
6. Insert brass rod (12) in knob (13). Attach dial indicating scale (14) to rod next to knob, as shown.
7. Pull scale (14) to rotate knob counterclockwise. Check force required to turn knob. Force shall not exceed **15 pounds**. Load beam (11) shall release **20-pound** load (10) and return to closed and latched position.
  - a. If load (10) does not release, or force exceeds **15 pounds**, check internal tip of load beam (11) for damage (Task 16-24, step 44.4).
  - b. If load beam (11) does not close and latch, release knob (13). Repeat step 7, pulling scale (14) more slowly. If beam still does not close and latch, reject hook.
8. Release knob (13).
9. Remove dial indicating scale (14) and brass rod (12).
10. Lower hoist (1).

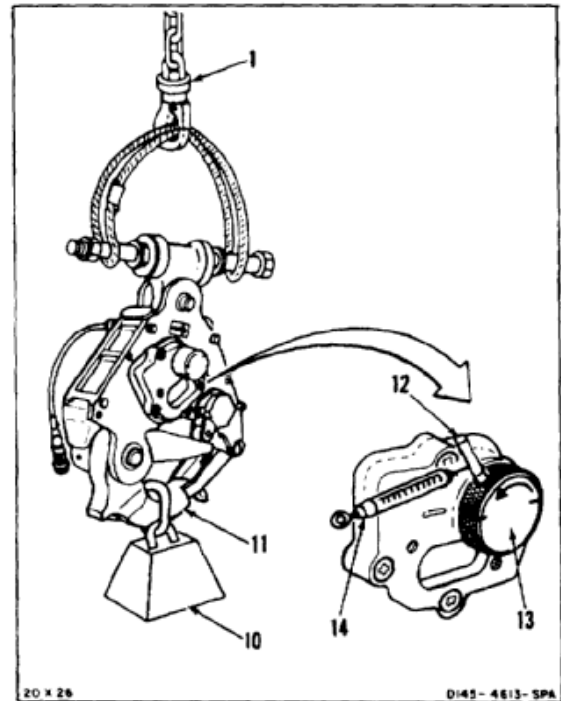

11. Connect test setup (15) to connector plug (16) pins C (+) and D.
12. Connect **80-pound** load (10) to load beam (11). Load shall be straight down and centered on beam.
13. Raise hoist (1) until load (10) clears ground.
14. Adjust power supply (17) to **22 volts**.
15. Press test switch (18). Load beam (11) shall release load (10) and return to closed and latched position.
  - a. If load (10) does not release, connect multimeter (18.1) between pins E and H of connector (16). If meter indicates **0 ohm** with test switch (18) pressed, replace relay (Task 16-24, step 21). If meter does not indicate **0 ohm**, repair solenoid wiring or replace solenoid ( Task 16-24, step 54).
  - b. If load beam (11) does not close and latch, release test switch (18) and repeat step 15. If beam still does not close and latch, reject hook.
16. Release test switch (18).
17. Disconnect test setup (15) from connector plug (16).

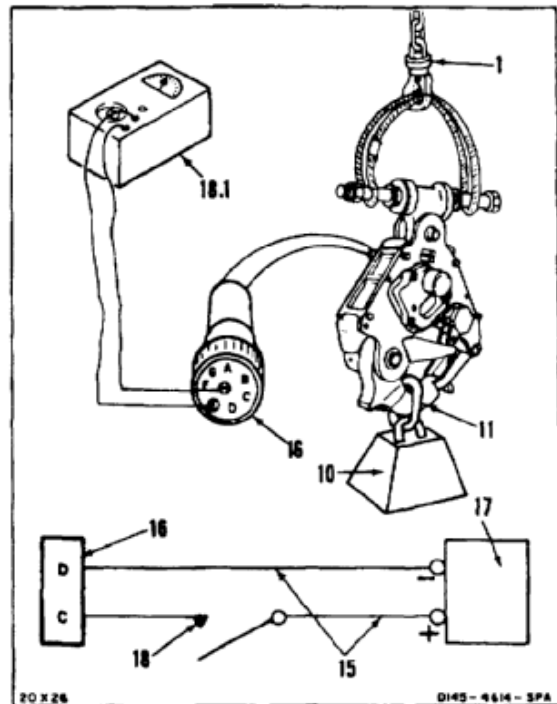

**16-29 FORWARD OR AFT CARGO HOOK FUNCTIONAL TEST (AVIM) (Continued)**

16-29

18. Connect **20-pound** load (10) to load beam (11). Load shall be straight down and centered on beam.
19. Raise hoist (1) until load (10) clears ground.
20. Attach dial indicating scale (14) to lockwire (7).
21. Pull scale (14) to release load (10). Check force required to release load. Force shall not exceed **25 pounds**. Load beam (11) shall release load and return to closed and latched position.
  - a. If load does not release, or force exceeds **25 pounds**, check internal tip of load beam (11) for damage (Task 16-24, step 44.4).
  - b. If load beam (11) does not close and latch, release lockwire (7). Repeat step 21, pulling scale (14) more slowly. If beam still does not close and latch, reject hook.
22. Remove dial indicating scale (14).
23. Lower hoist (1).

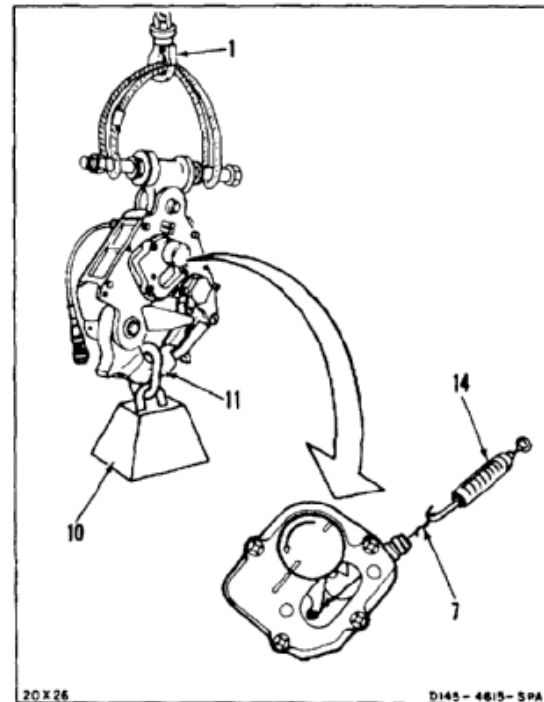

24. Connect test setup (15) to connector plug (16), pins H (+) and E.
25. Connect **20-pound** load (10) to load beam (11). Load shall be straight down and centered on beam.
26. Raise hoist (1) until load (10) clears ground.
27. Adjust power supply (17) to **22 volts**.
28. Press test switch (18). Load beam (11) shall release **20-pound** load (10) and return to closed and latched position.
  - a. If load (10) does not release, repair solenoid wiring or replace solenoid (Task 16-24, step 54).
  - b. If load beam (11) does not close and latch, release test switch (18) and repeat step 28. If beam still does not close and latch, reject hook.
29. Release test switch (18).
30. Disconnect test setup (15) from connector plug (16).
31. Cycle keeper (19). Make sure keeper is spring-loaded down.

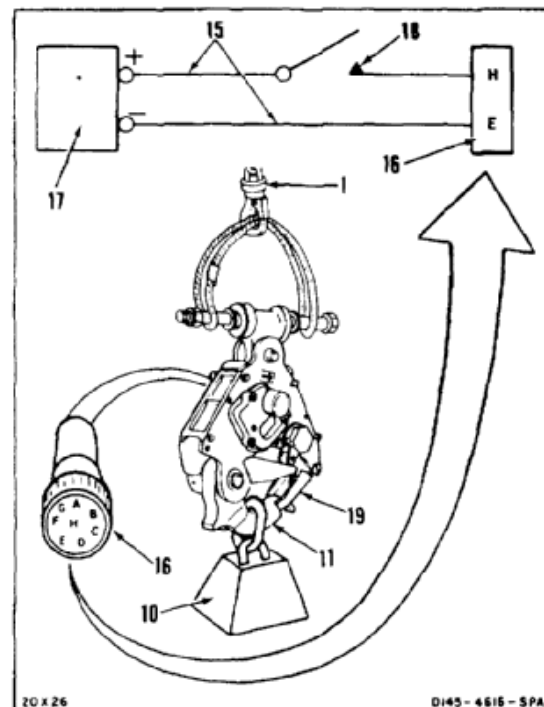

32. Remove lockwire (7) from cable adapter (8) and arm (9).
33. Position inspection window (6). Install two bolts (4) and washers (5).
34. Torque bolts (4) to **40 inch-pounds**.
35. Lockwire bolts (4) and cable adapter (8) together. Use lockwire (E231).
36. Lower hoist (1) and remove hook (3).

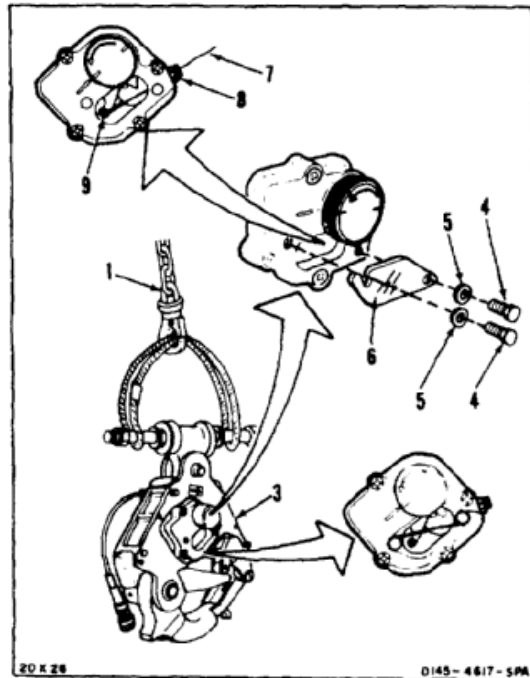
**FOLLOW-ON MAINTENANCE:**

Pressure test solenoid cover (Task 16-30).

END OF TASK

INITIAL SETUP

**Applicable Configurations:**

All

**Tools:**

- Aircraft Mechanic's Tool Kit, NSN 5180-00-323-4692
- Stopwatch
- Stowage Coupling MS3180-16C
- Regulator
- Pressure Gage, 0 to 30 psi
- Shutoff Valve
- Torque Wrench, 30 to 150 Inch-Pounds
- Air Hose
- Source Of Low Pressure Compressed Air

**Materials:**

None

**Parts:**

Packing

**Personnel Required:**

- Aircraft Electrician
- Inspector

**Equipment Condition:**

- Off Helicopter Task
- Air Pressure Test Setup

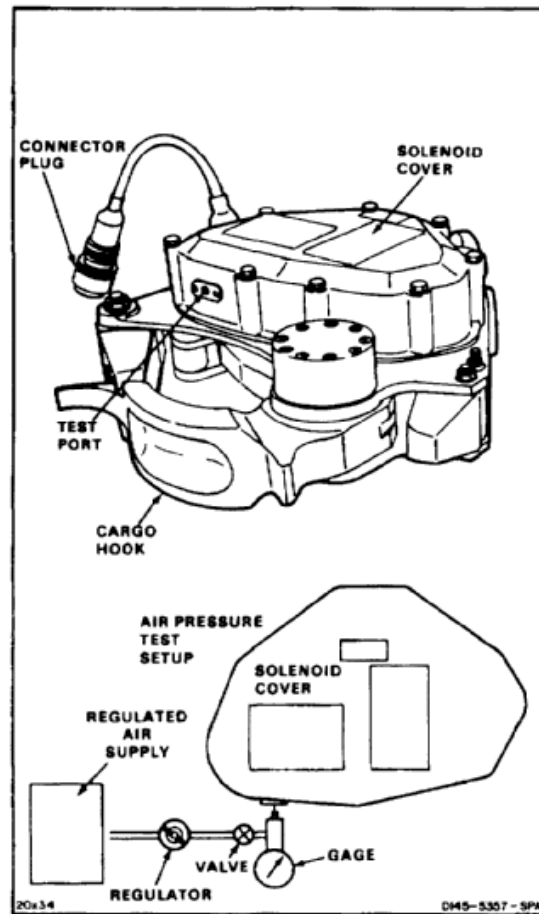

**NOTE**

Only solenoid cover of cargo hook is shown here for clarity.

Procedure is same to test forward or aft cargo hook.

1. Install stowage coupling (1) on connector plug (2).
2. Remove bolt (3), washer (4), and packing (5) from test port (6) of solenoid cover (7).

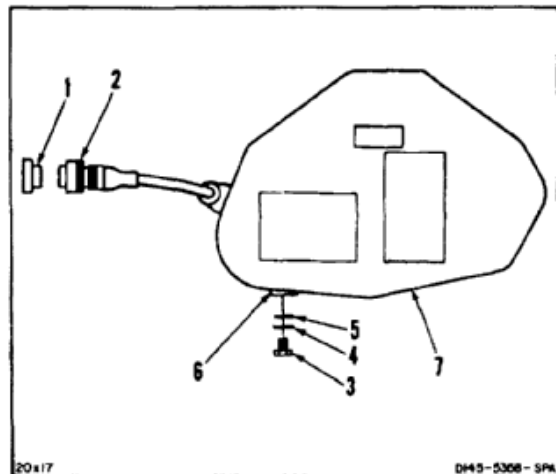

3. Close valve (8) of test setup. Connect test setup to air supply (9).
4. Adjust regulator (10) to **0 psi**.
5. Connect test setup to test port (6).

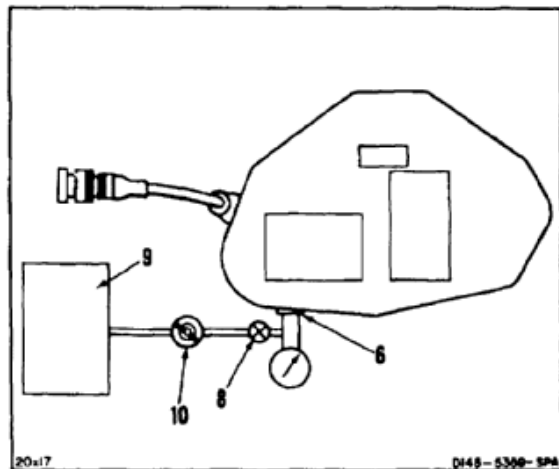

6. Open valve (8).

**WARNING**

Do not apply more than **10 psi** air pressure to test port. Otherwise, damage to solenoid cover or injury to personnel can occur.

7. Adjust regulator (10) for **5.5 psi** on gage (11).
8. Close valve (8). Adjust air supply regulator (10) to **0 psi**.
9. Check gage (11) for pressure loss. There shall be no pressure loss for **30 minutes**.

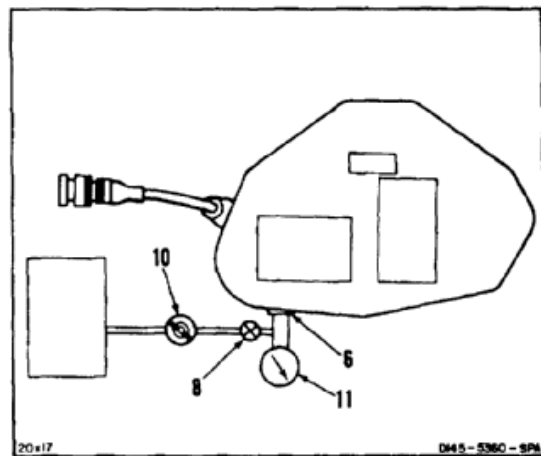

10. Open valve (8) and reduce pressure at port (6) to **0 psi**.
11. Disconnect test setup from port (6) and from air supply (9).

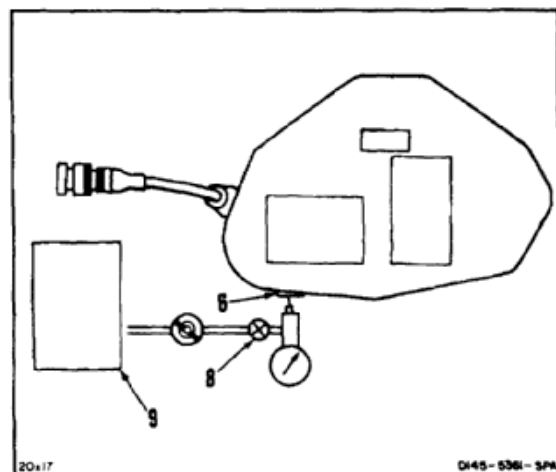

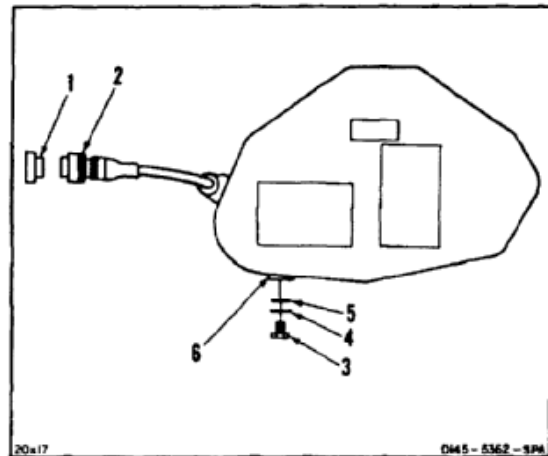

12. Install packing (5), washer (4), and bolt (3) in port (6). Torque bolt to **50 inch-pounds**.
13. Remove stowage coupling (1) from connector plug (2).

***FOLLOW-ON MAINTENANCE:***

None

END OF TASK

## INITIAL SETUP

**Applicable Configurations:**

All

**Tools:**

Aircraft Mechanic's Tool Kit, NSN 5180-00-323-4692  
Torque Wrench, 30 to 150 Inch-Pounds

**Materials:**

Lockwire (E231)  
Cloths (E120)

**Personnel Required:**

Medium Helicopter Repairer (2)  
Inspector

**References:**

TM 55-1520-240-23P

**General Safety Instructions:****WARNING**

If helicopter has been flown since cargo hook was removed, battery must be disconnected and electrical power must be off. Otherwise, injury to personnel can occur.

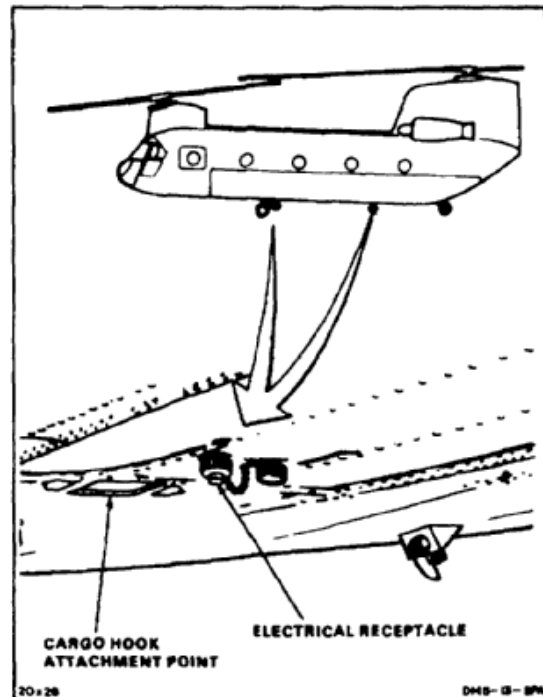

**NOTE**

Forward and aft cargo hooks are installed in same way.

If manual release cable is installed, and forward access plate and aft access plate are removed, go to step 8. Perform steps 1 thru 7 if cargo hook was removed for a mission.

1. Remove screw (1). Remove forward access plate (2) from fuselage.
2. Remove screw (3). Remove aft access plate (4) from fuselage.

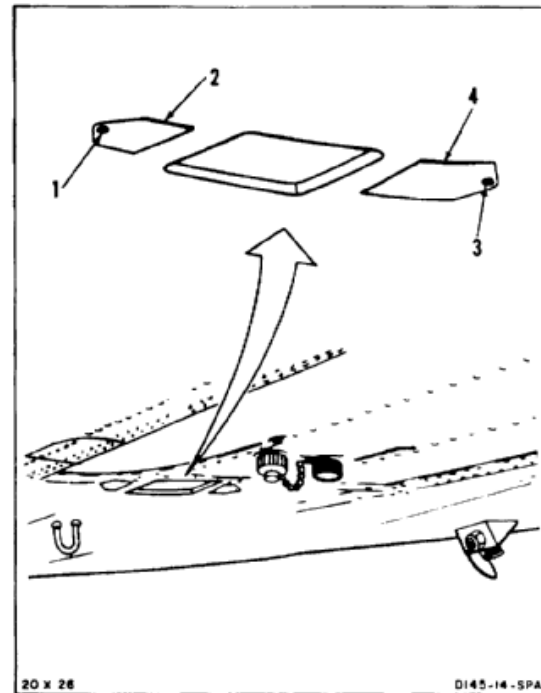

3. Remove cap (5) from bulkhead fitting (6). Install cap on stowage fitting (7).

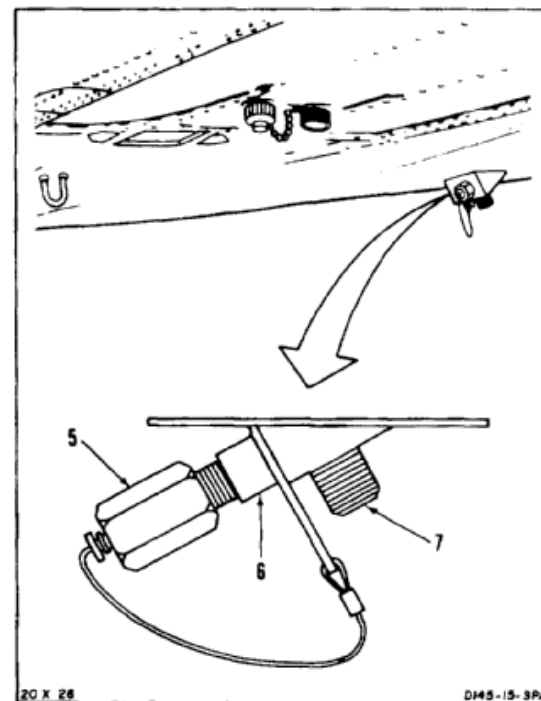

4. Slide ball end attachment (8) of cable (9) into recess in cable attachment (10).
5. Slide outer sleeve (11) up cable (9) and position over fitting (6).
6. Tighten nut (12) on fitting (6).

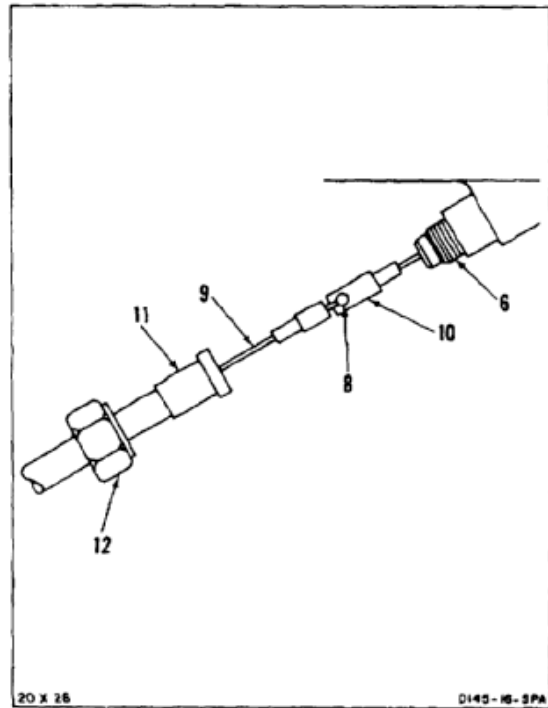

7. Put free end of control assembly (13) through clamp (14).

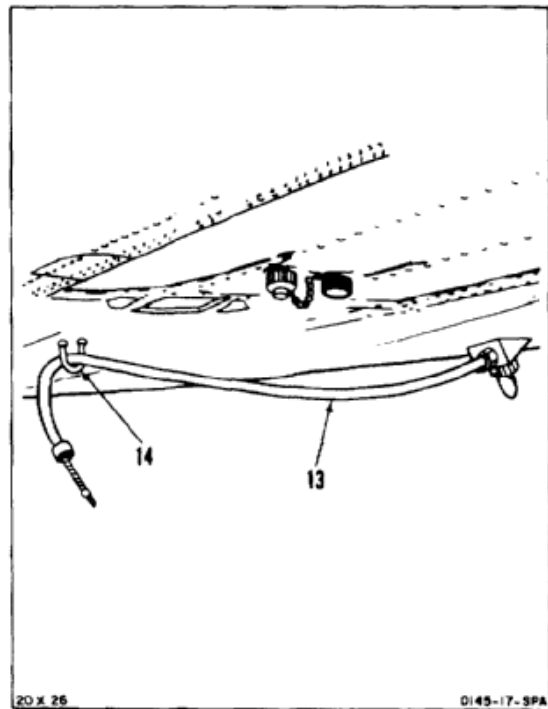

**16-31 INSTALL FORWARD AND AFT CARGO HOOK (Continued)**

16-31

8. Position cargo hook (15) with keeper (16) forward. Position hook fitting (17) in fuselage fitting (18).
9. Have helper support weight of hook (15) and align holes in hook with holes in fitting. Push up on safety stop (19) and install pivot bolt (20).
10. Install washer (21) and nut (22) on bolt (20). Torque nut to **100 to 140 inch-pounds**.

**WARNING**

Safety stop must be fully extended to prevent bolt from falling out of fitting. Loss of bolt will result in loss of cargo hook and external load, causing injury or death to personnel.

11. Make sure safety stop (19) moves down to block bolt (20).

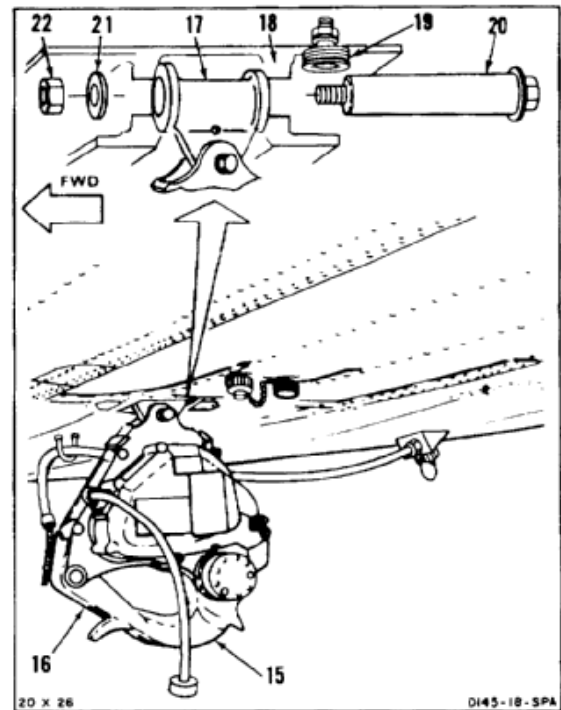

12. Position forward access plate (2) over hole in fuselage, with clip slot (23) around rivet tail (24).
13. Install screw (1).
14. Position aft access plate (4) over hole in fuselage, with clip slot (25) around rivet tail (26).
15. Install screw (3).

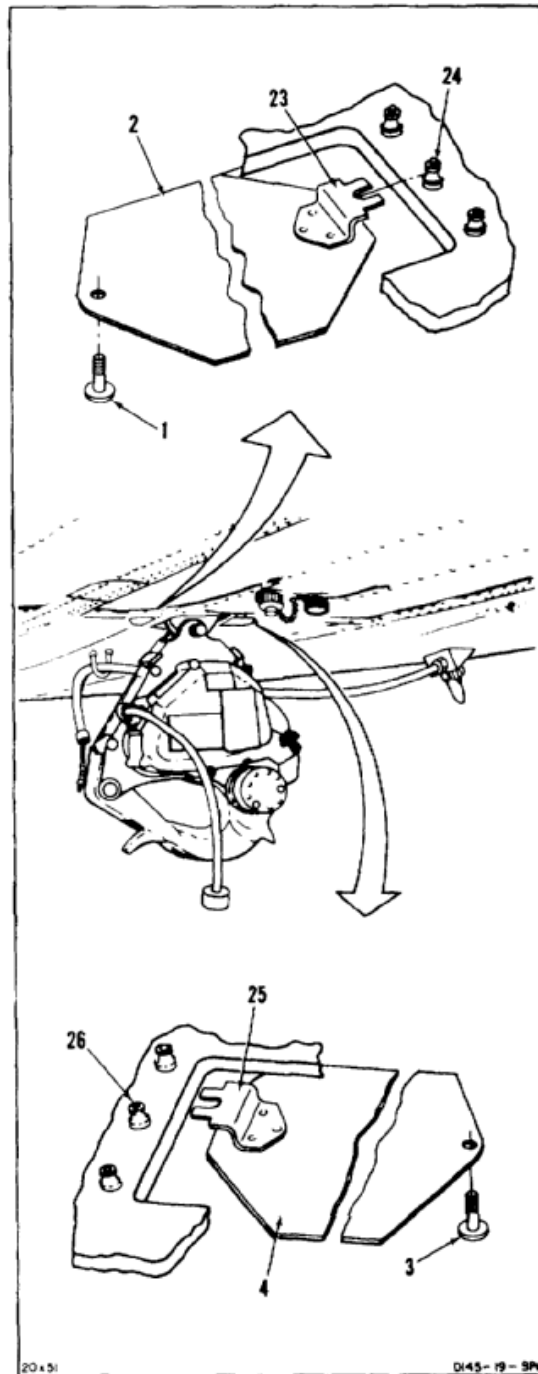

16. Loosen bolt (27). Remove bolt (28) and washer (29).
17. Remove inspection window (30).

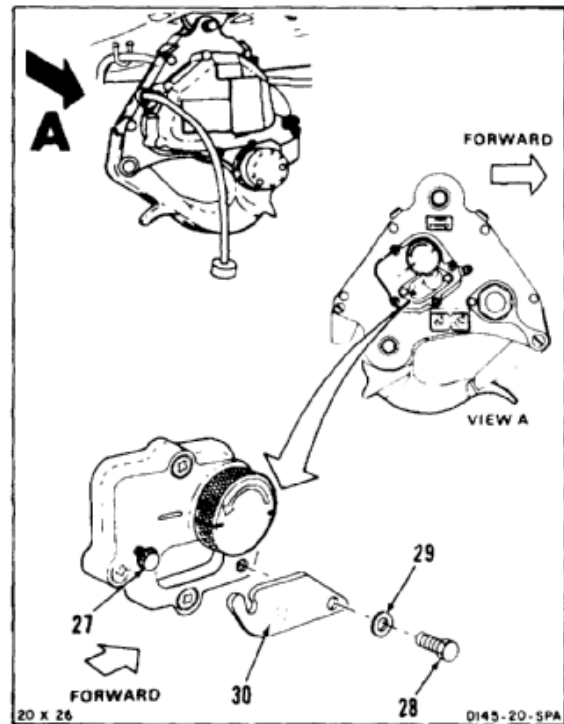

18. Move release arm (31) straight down and hold.
19. Loosen screw (32). Feed cable (9) through cable adapter fitting (33).
20. Position ball end (34) of cable (9) into arm (31). Tighten screw (32). Let go of arm (31).
21. Tighten nut (35) on cable adapter fitting (33).

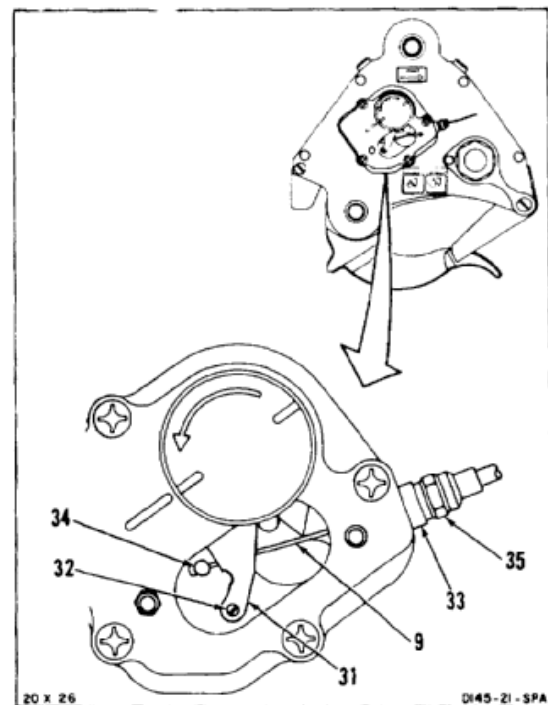

**WARNING**

Improper adjustment of release cable can result in loss of external load. Personnel can be injured or killed.

- 22. Push up release arm (31).
- 23. Make sure clearance is **0.00 to 0.20 inch** between ball end (34) and arm (31).

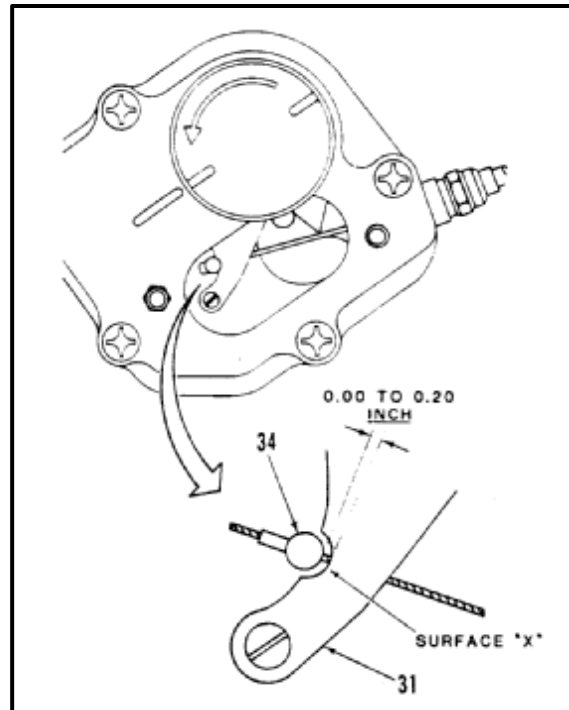

- 24. Clean and dry window (30), and area around hole. Use cloths (E120).
- 25. Position window (30) on hook (15). Install bolt (28) and washer (29).
- 26. Torque bolts (27 and 28) to **40 inch-pounds**. Lockwire bolts, cable adapter (33), and nut (35) together. Use lockwire (E231).

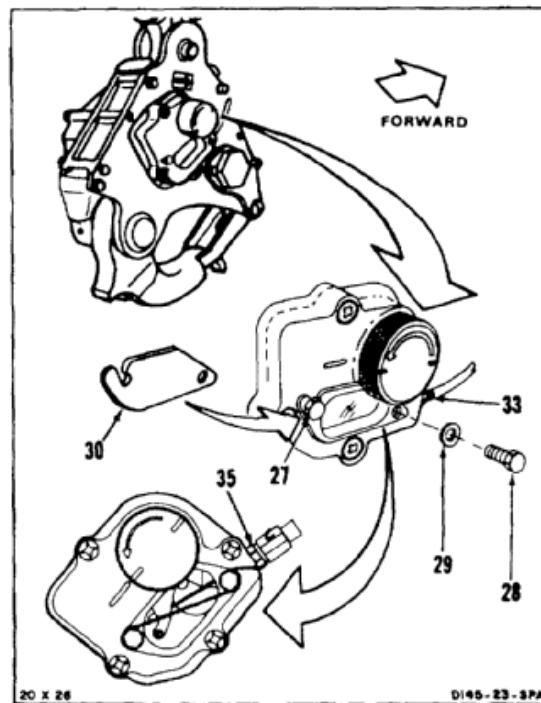



**16-31 INSTALL FORWARD AND AFT CARGO HOOK (Continued)**

16-31

27. Remove cap (36) from receptacle (37) and install on stowage location (38).
28. Connect plug (39) to receptacle (37). Tighten lockring (40).

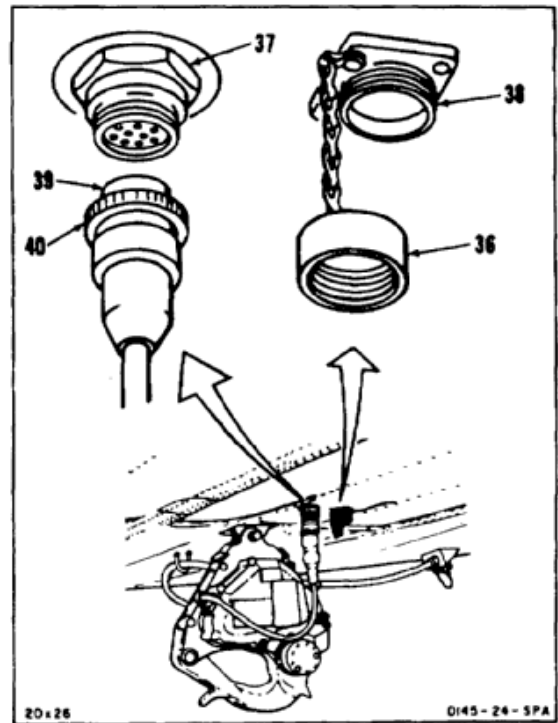
**INSPECT****FOLLOW-ON MAINTENANCE:**

Perform operational check (TM 55-1520-240-T).

END OF TASK

INITIAL SETUP

**Applicable Configurations:**

All

**Tools:**

Aircraft Mechanic's Tool Kit, NSN 5180-00-323-4692

**Materials:**

None

**Personnel Required:**

Medium Helicopter Repairer

**Equipment Condition:**

Battery Disconnected (Task 1-39)  
Electrical Power Off

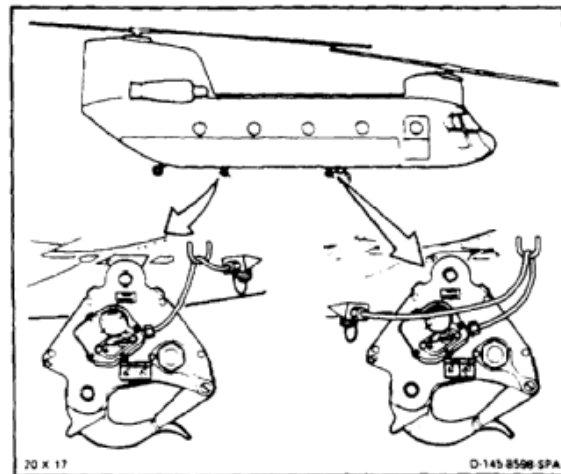

**NOTE**

Procedure to remove forward or aft external manual release cable is same. Forward cable shown here.

1. Remove lockwire and loosen two bolts (1 and 2).

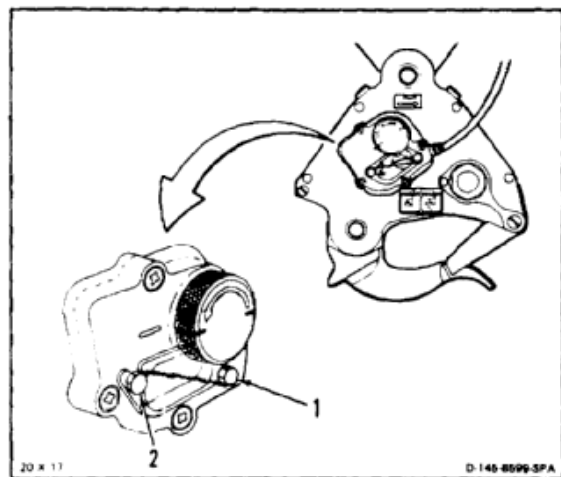

2. Swing inspection window (3) down to gain access to release arm (4).
3. Move release arm (4) down and hold. Loosen screw (5). Remove cable (6) from arm.
4. Remove lockwire from nut (7). Loosen nut and disconnect cable housing (8).

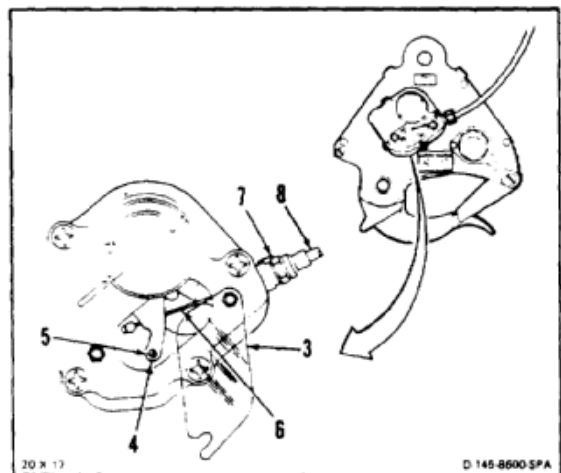

**16-32 REMOVE FORWARD OR AFT CARGO HOOK EXTERNAL MANUAL RELEASE CABLE (Continued)**

16-32

5. Position inspection window (3) on bolt (2). Tighten bolts (1 and 2).
6. Loosen nut (9).
7. Slide sleeve (10) down cable housing (8).
8. Remove cable ball end (11) from inner cable attachment (12). Remove cable housing (8).
9. Remove cap (13) from stowage fitting (14). Install cap on feed thru fitting (15).

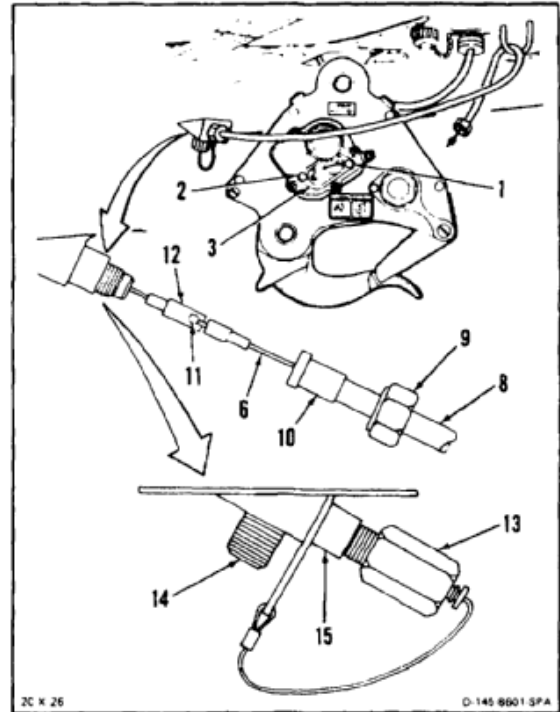
**FOLLOW-ON MAINTENANCE:**

None

END OF TASK

INITIAL SETUP

**Applicable Configurations:**

All

**Tools:**

Aircraft Mechanic's Tool Kit, NSN 5180-00-323-4692  
Torque Wrench, 30 to 150 Inch-Pounds

**Materials:**

Cloths (E120)  
Lockwire (E231)

**Personnel Required:**

Medium Helicopter Repairer  
Inspector

**References:**

TM 55-1520-240-23P

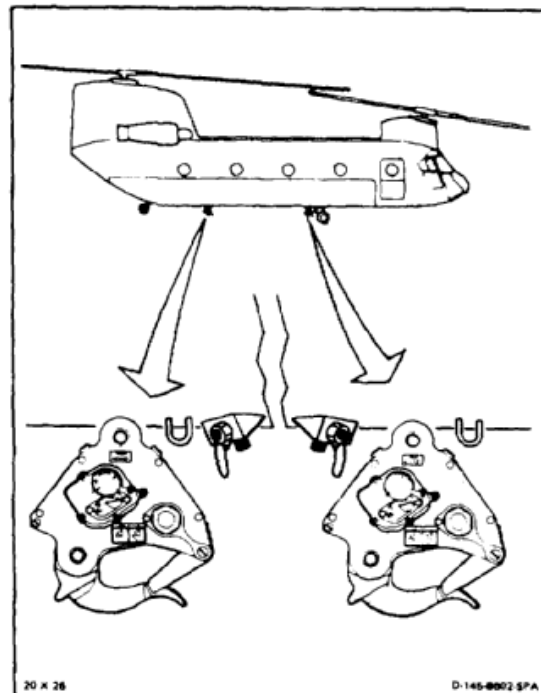

**NOTE**

Procedure is same to install forward or aft external manual release cable. Forward cable shown here.

1. Remove cap (1) from feed-thru fitting (2). Install cap on stowage fitting (3).

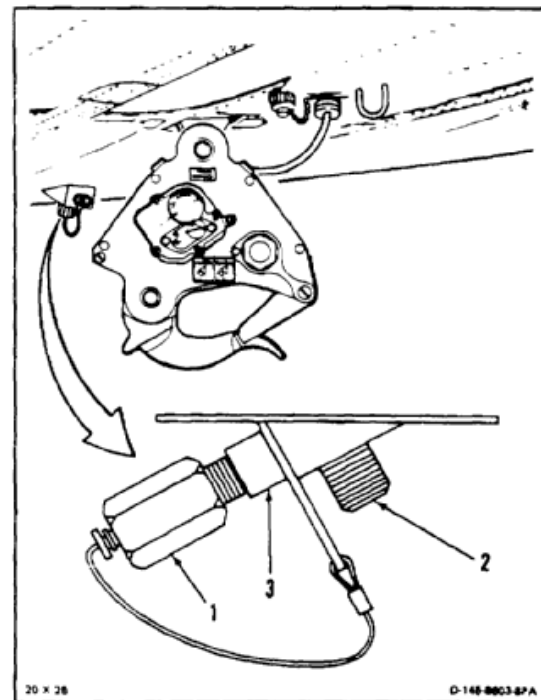

**16-33 INSTALL FORWARD OR AFT CARGO HOOK EXTERNAL MANUAL RELEASE CABLE (Continued)**

2. Pull cable attachment (4) from bulkhead fitting (2).
3. Slide ball end attachment (5) of cable (6) into recess in cable attachment (4).
4. Slide outer sleeve (7) up cable (6) and position over fitting (2).
5. Tighten nut (8) on fitting (2).

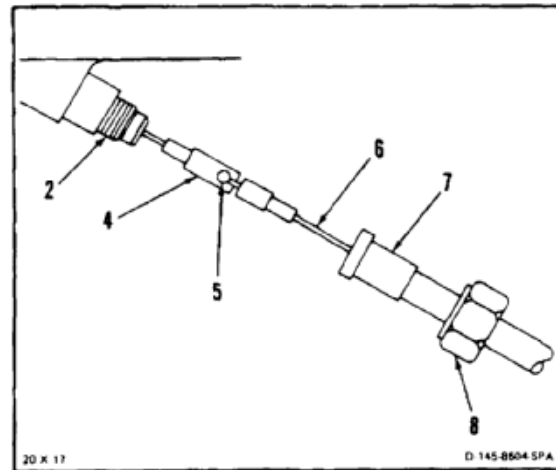

6. On forward cargo hook, insert free end of cable (6) through clamp (9).

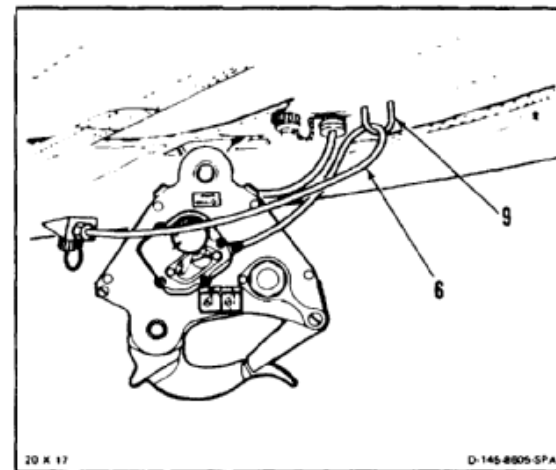

7. Loosen bolt (10). Swing inspection window (11) down to clear release arm (12).
8. Move release arm (12) straight down and hold.
9. Loosen screw (13). Feed cable (6) through cable adapter fitting (14).
10. Position ball end (15) of cable (6) into arm (12). Tighten screw (13). Let go of arm (12).
11. Tighten nut (16) on cable adapter fitting (14).

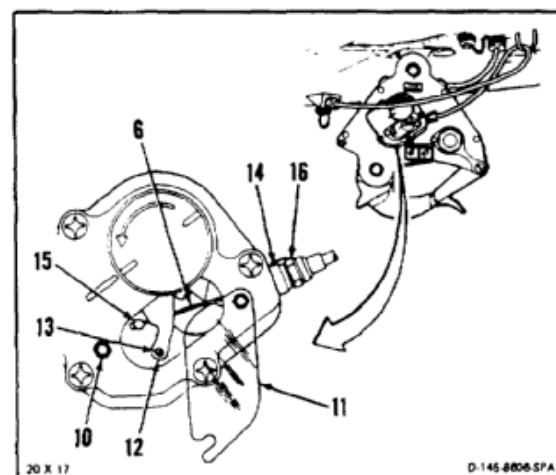

**WARNING**

Improper adjustment of release cable can result in loss of external load. Personnel can be injured or killed.

12. Push up release arm (12).
13. Make sure clearance is **0.00 to 0.20 inch** between ball end (15) and 'X' of arm (12).
- 13.1. If gap is not within limits, adjust forward or aft cargo hook manual release cable (Task 16-35.1).

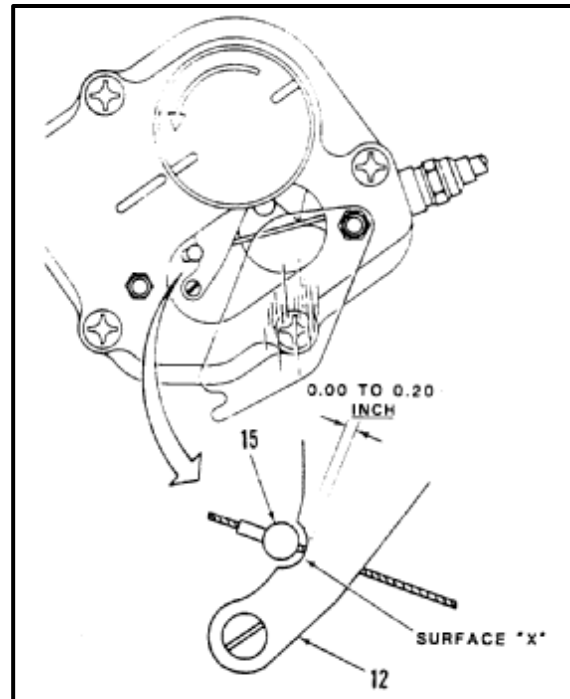

14. Clean and dry window (11), and area around hold. Use cloths (E120).
15. Position window (11) on bolt (10). Tighten bolts (10 and 17). Torque two bolts (10 and 17) to **40 inch-pounds**. Lockwire bolts, cable adapter fitting (14) and nut (16) together. Use lockwire (E231).

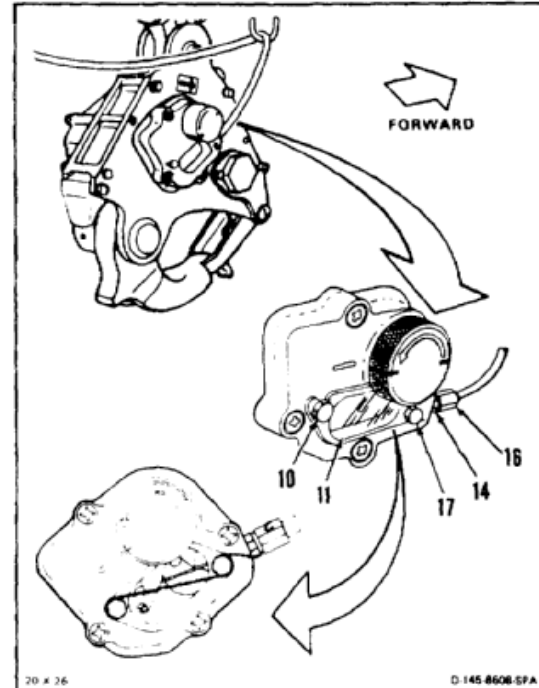
**INSPECT****FOLLOW-ON MAINTENANCE:**

Perform operational check (TM 55-1520-240-T).

END OF TASK

16-182

**INITIAL SETUP**

**Applicable Configurations:**

All

**Tools:**

Aircraft Mechanic's Tool Kit, NSN 51 80-00-323-4692

**Materials:**

None

**Personnel Required:**

Medium Helicopter Repairer

**Equipment Condition:**

- Battery Disconnected (Task 1-39)
- Electrical Power Off
- Hydraulic Power Off
- Right Center Cabin Floor Panel (Sta 240 to Sta 320) or Right Center Cabin Floor Panel (Sta 360 to Sta 486) Removed (Task 2-204)
- Center Hook Access Door Opened (Task 2-2)

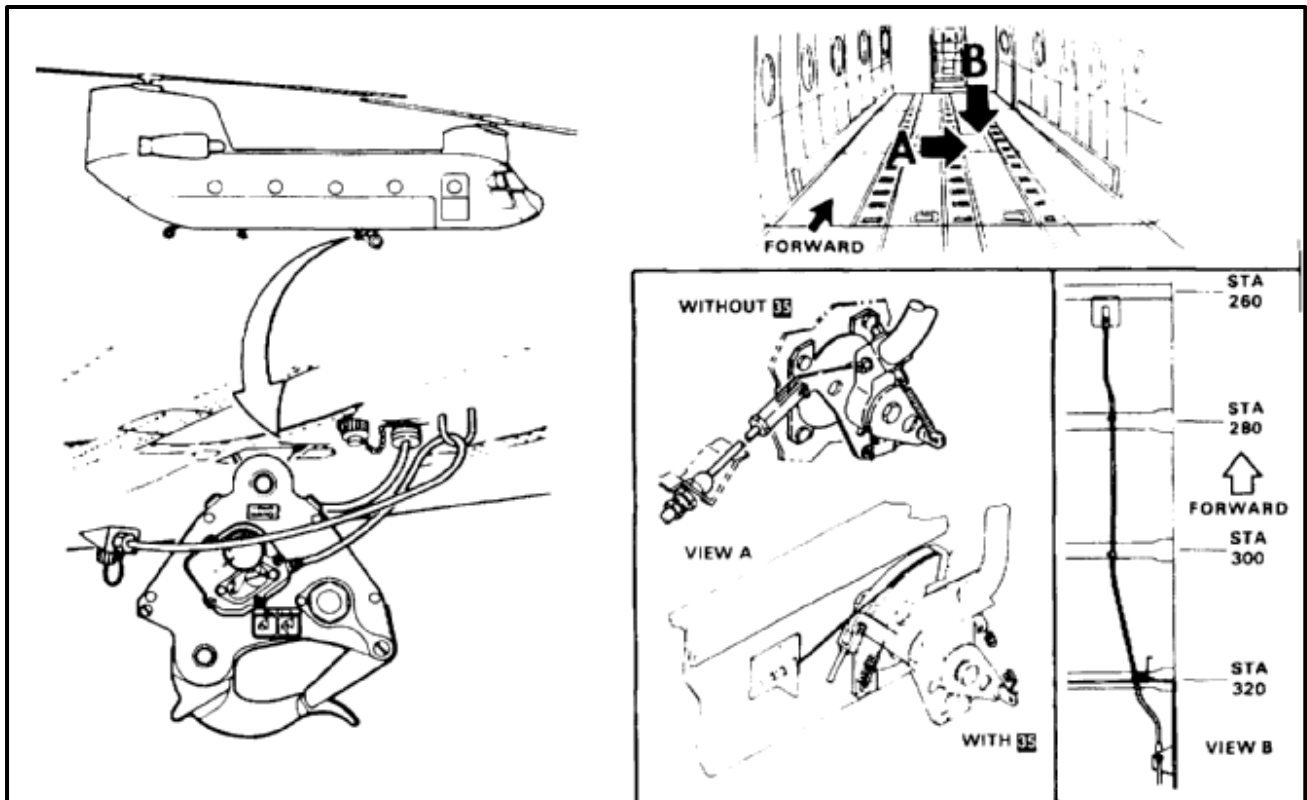

**NOTE**

Procedure is same to remove forward or aft cargo hook interior manual release cable except as noted. Forward cable shown here.

1. Loosen nut (1).
2. Slide sleeve (2) down cable (3).
3. Remove cable ball end (4) from inner cable attachment (5).

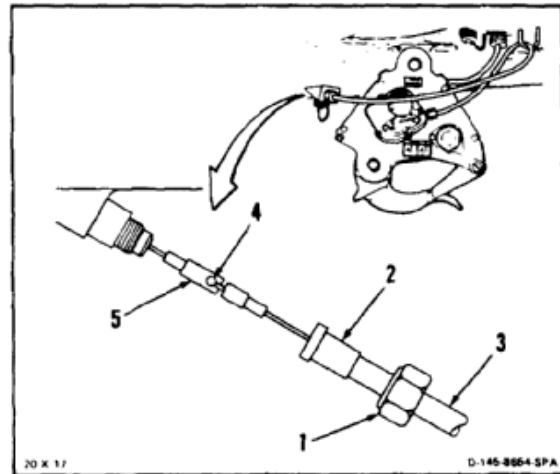

4. Working in cabin rescue hatch, remove lockwire and loosen locknut (7).
5. Remove cotter pin (8), washer (9), and pin (10) from clevis (11).
6. Remove lockwire from cable retaining nut (12) and swivel fitting locknut (13).
7. Hold swivel fitting (14) and remove retaining nut (12) and locknut (13).
8. Remove clevis (11), locknut (7) and swivel fitting (14) from cable (15).
9. Pull end of cable (15) through bracket (16).

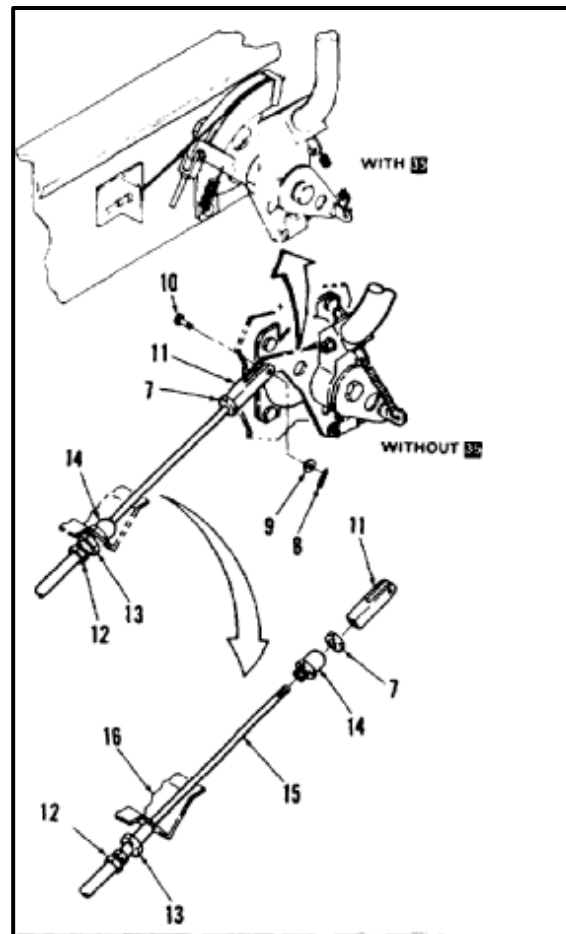



**16-34 REMOVE FORWARD OR AFT CARGO HOOK INTERIOR MANUAL RELEASE CABLE (Continued)**

16-34

10. Remove three support clamps (17).
11. Remove lockwire and cable retaining nut (18) from feed-thru fitting (19).
12. Remove cable (15) from fitting (19). Remove cable (15).

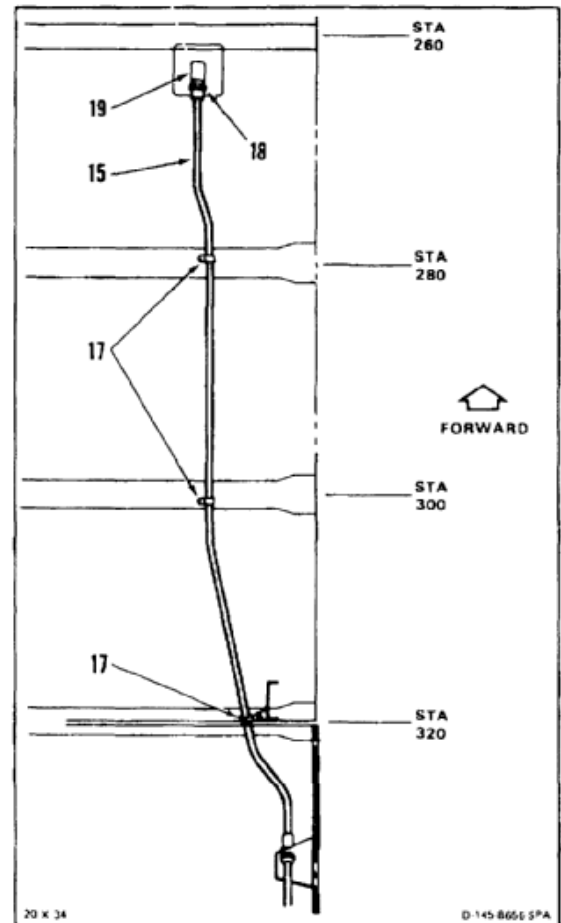
***FOLLOW-ON MAINTENANCE:***

None

END OF TASK

INITIAL SETUP

**Applicable Configurations:**

All

**Tools:**

Aircraft Mechanic's Tool Kit, NSN 5180-00-323-4692  
Torque Wrench, 5 to 50 Inch-Pounds

**Materials:**

Lockwire (E231)

**Parts:**

Cotter Pins

**Personnel Required:**

Medium Helicopter Repairer (2)  
Inspector

**References:**

TM 55-1520-240-23P

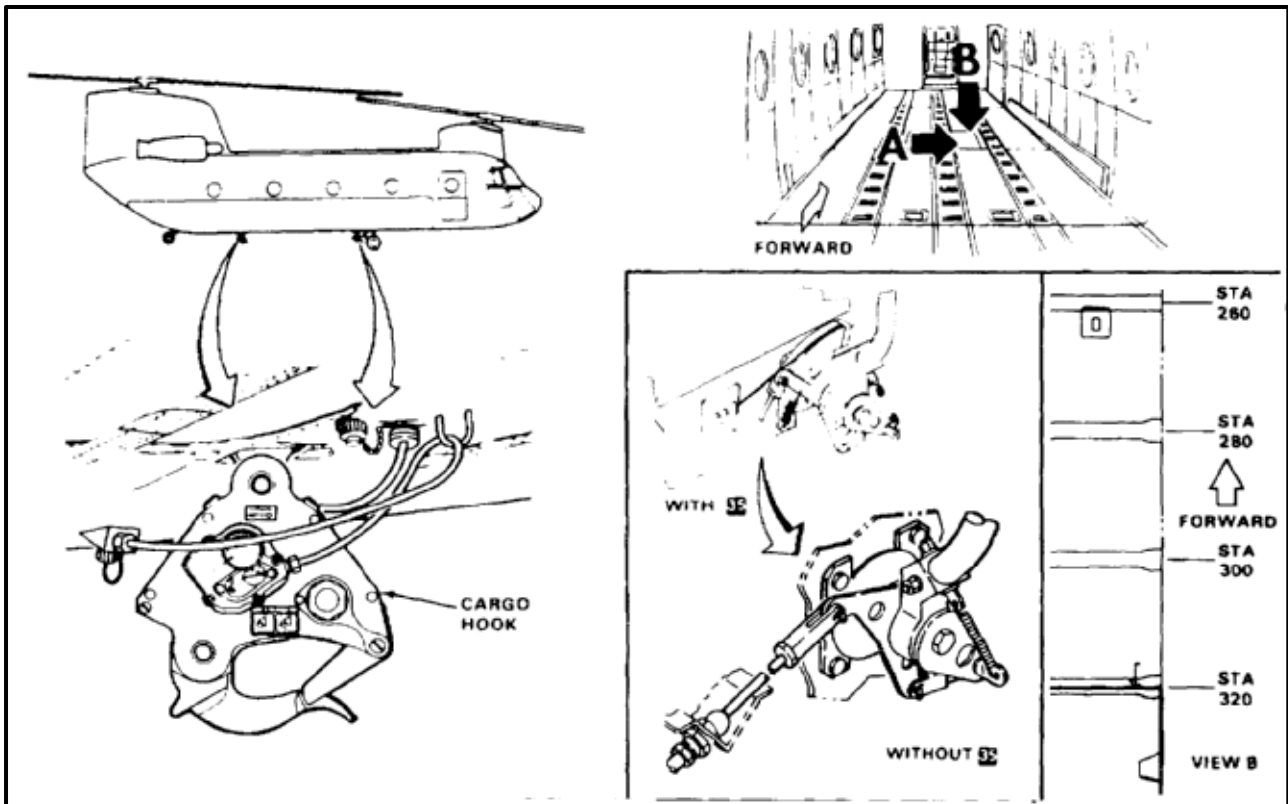

**16-35 INSTALL FORWARD OR AFT CARGO HOOK INTERNAL MANUAL RELEASE CABLE (Continued)**

**NOTE**

Procedure is same to install forward or aft cargo hook internal manual release cable except as noted. Forward cable shown here.

1. Route cable (1) through floor beams and install in feed-thru fitting (2).
2. Tighten cable retaining nut (3). Lockwire retaining nut. Use lockwire (E231).

**NOTE**

On aft cargo hook interior manual release cable there are two support clamps.

3. Install three support clamps (4) on cable (1).

**WARNING**

The clamps at sta 280 and 300 must be positioned with the cable outboard of the damp retaining bolt. This places the cable between floor "I" sections; not under one, where the cable could be crushed.

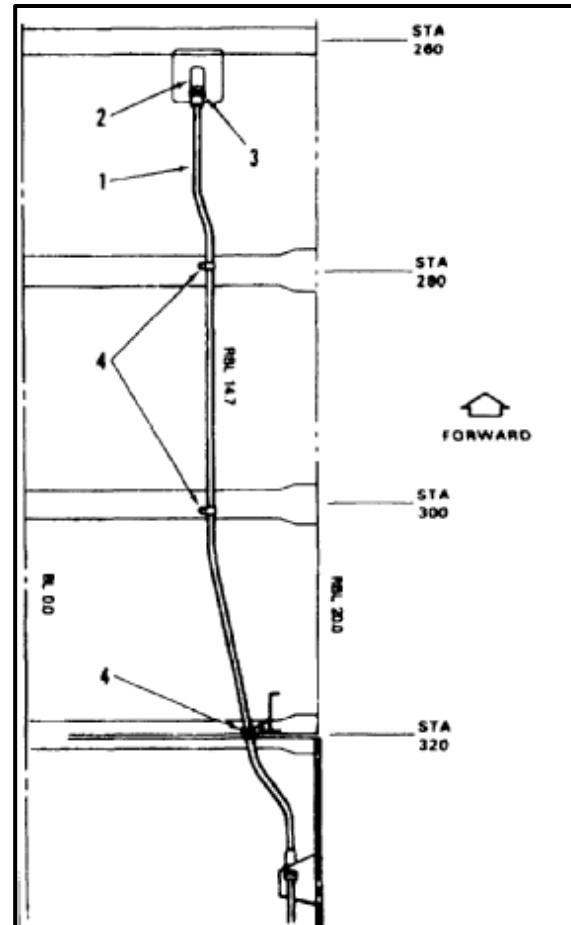

4. Working under aircraft at forward cargo hook feed-thru fitting (2), pull out cable attachment (5).
5. Slide ball end attachment (6) of cable (1) into recess in cable attachment (5).
6. Slide outer sleeve (7) up cable (1) and position over fitting (2).
7. Tighten nut (8) on fitting (2).

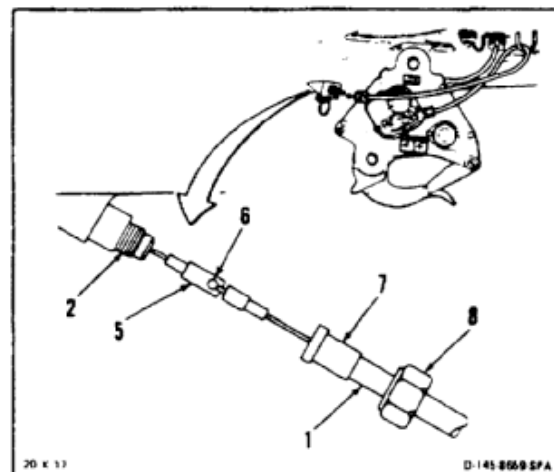

8. Working in rescue hatch compartment, install swivel fitting locknut (9) on cable (1).
9. Route end of cable (1) through bracket (10).

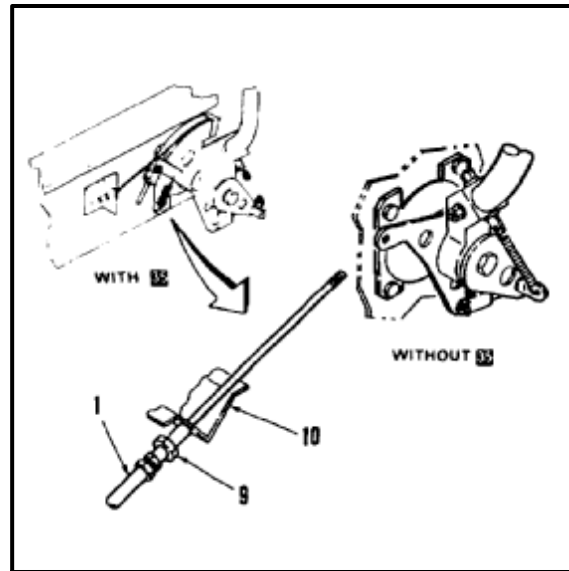

10. Slide swivel fitting (11) over cable (1) into bracket (10).
11. Hold swivel fitting (11) and install swivel fitting locknut (9) and cable retaining nut (13).
12. Lockwire fitting (11), locknut (9) and retaining nut (13) together. Use lockwire (E231).

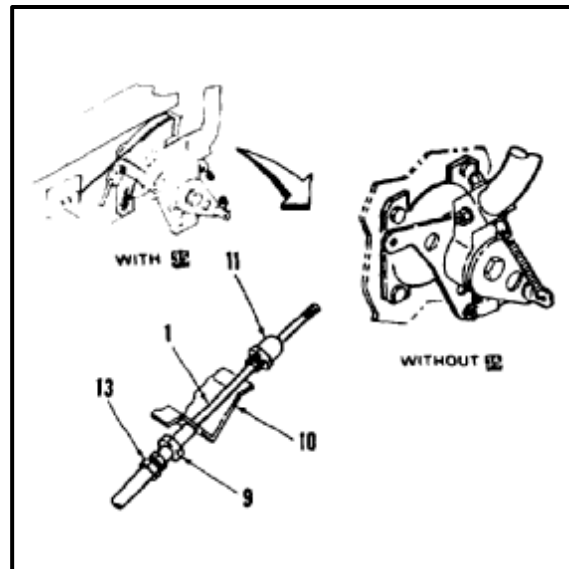

**16-35 INSTALL FORWARD OR AFT CARGO HOOK INTERNAL MANUAL RELEASE CABLE (Continued)**

16-35

13. Install locknut (14) and clevis (15) on cable (1).
14. Align holes in clevis (15) and manual release bellcrank (16). Install pin (17), washer (18), and cotter pin (19).

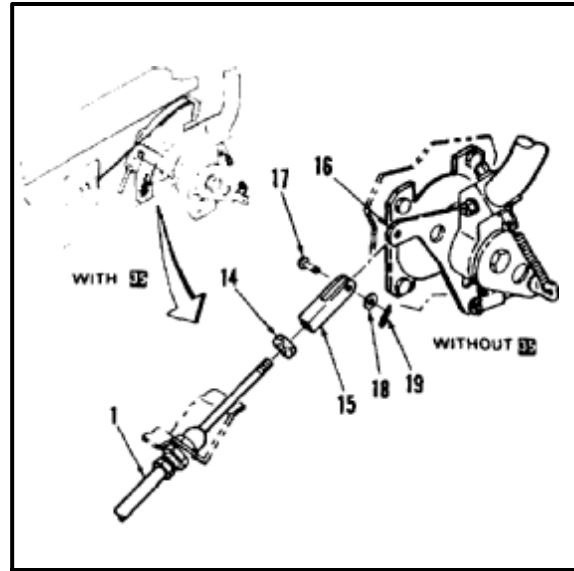

15. Have helper, working at forward hook, remove lockwire from inspection window retaining bolts (20 and 21).
16. Loosen bolts (20 and 21). Swing inspection window (22) down.
17. Make sure clearance is **0.00 to 0.20 inch** between ball end (23) and surface 'X' of release arm (24).
- 17.1. If gap is not within limits, adjust forward or aft cargo hook manual release cable (Task 6-35.1).

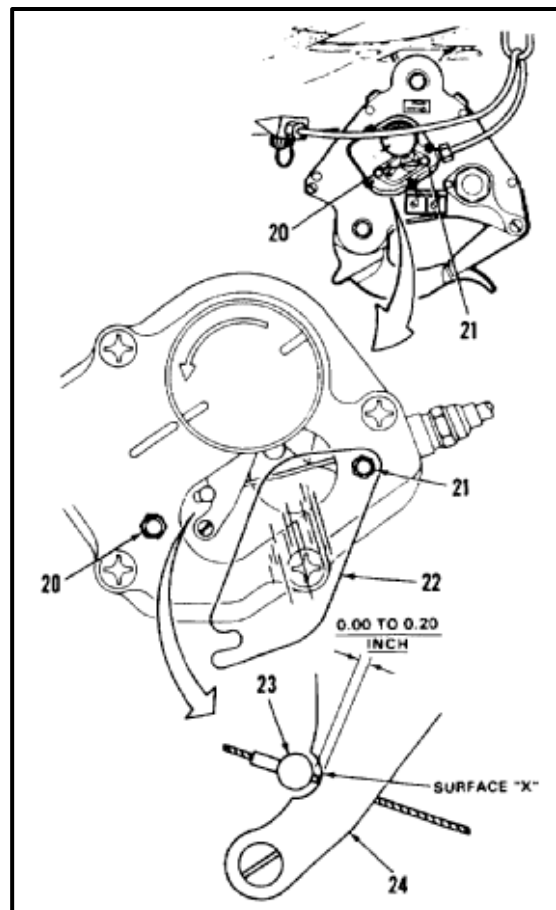

18. Tighten locknut (14) against clevis (15). Lockwire locknut and clevis together. Use lockwire (E231).

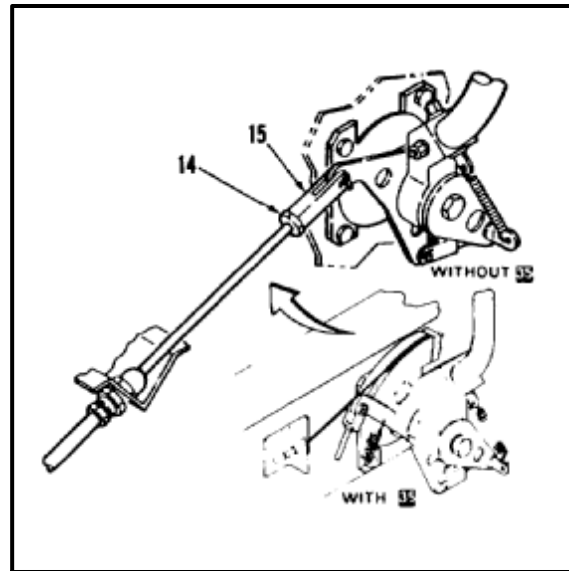

19. Position window (22) on retaining bolt (20).
20. Torque bolts (20 and 21) to **40 inch-pounds**. Lockwire bolts, cable adapter (25) and nut (26) together. Use lockwire (E231).

**FOLLOW-ON MAINTENANCE:**

Perform operational check (TM 55-1520-240-T).  
 Close center hook access door (Task 2-2).  
 Close right center cabin floor panel (Sta 240 to 320)  
 or right center cabin floor panel (Sta 360 to Sta 486) (Task 2-207).

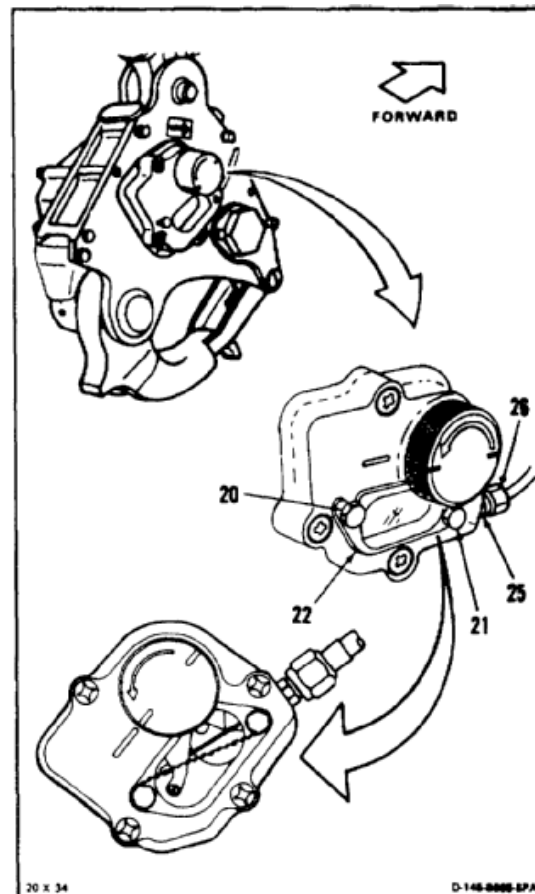

END OF TASK

**INITIAL SETUP**

**Applicable Configurations:**

All

**Tools:**

Aircraft Mechanic's Tool Kit, NSN 5180-00-323-4692  
Torque Wrench, 5 to 50 Inch-Pounds

**Materials:**

Lockwire (E231)

**Parts:**

Cotter Pins

**Personnel Required:**

Medium Helicopter Repairer (2)  
Inspector

**References:**

TM 55-1520-240-23P

**Equipment Condition:**

Battery Disconnected (Task 1-39)  
Electrical Power Off  
Hydraulic Power Off

**General Safety Instructions:**

**WARNING**

Improper adjustment of release cables can result in loss of external load. Personnel can be seriously injured or killed.

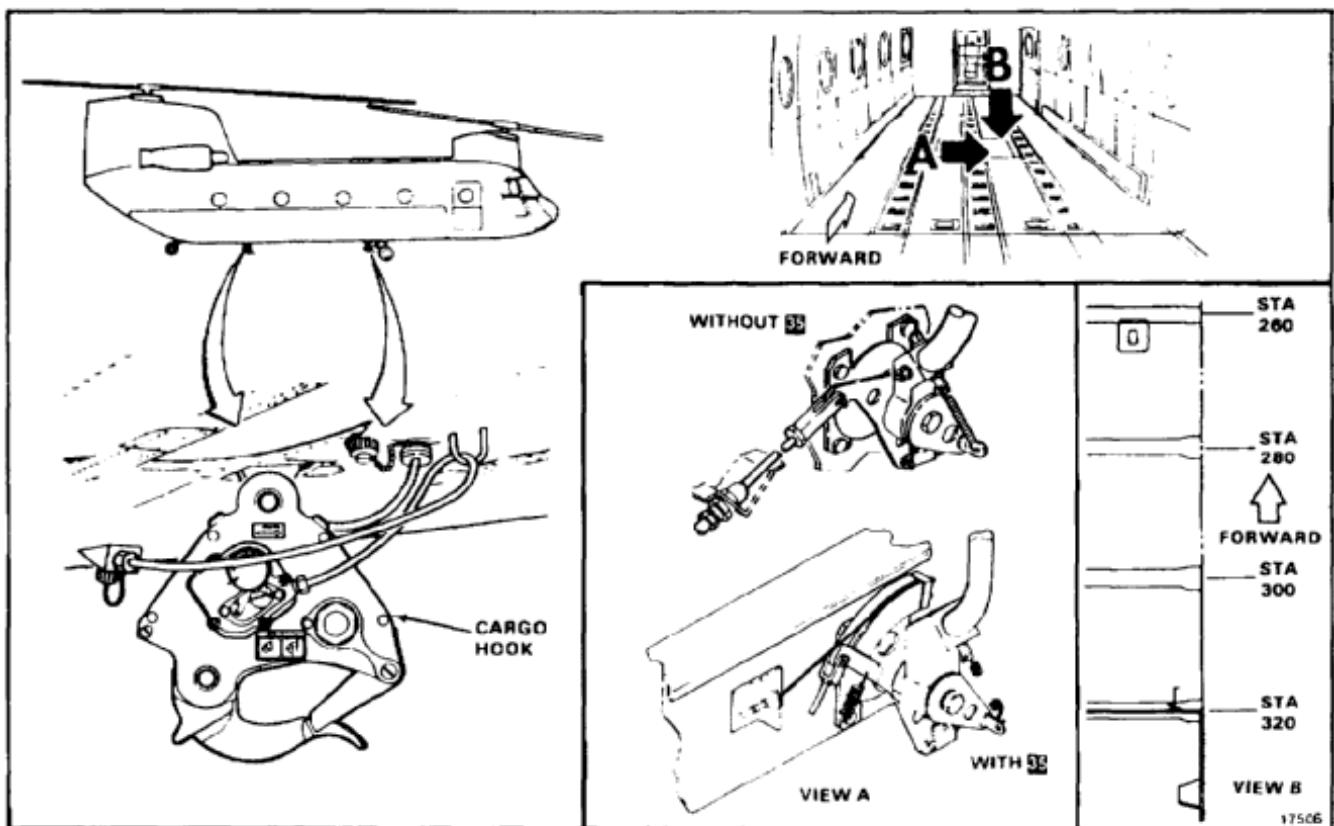

**NOTE**

Manual release system final adjustment shall be accomplished with cargo hooks (1) installed and mated with external cable assemblies (2).

Procedure is same to adjust forward or aft cargo hook release cable. Forward hook is shown.

1. Remove lockwire from inspection window retaining bolts (3 and 4).
2. Loosen bolts (3 and 4). Swing inspection window (5) down.

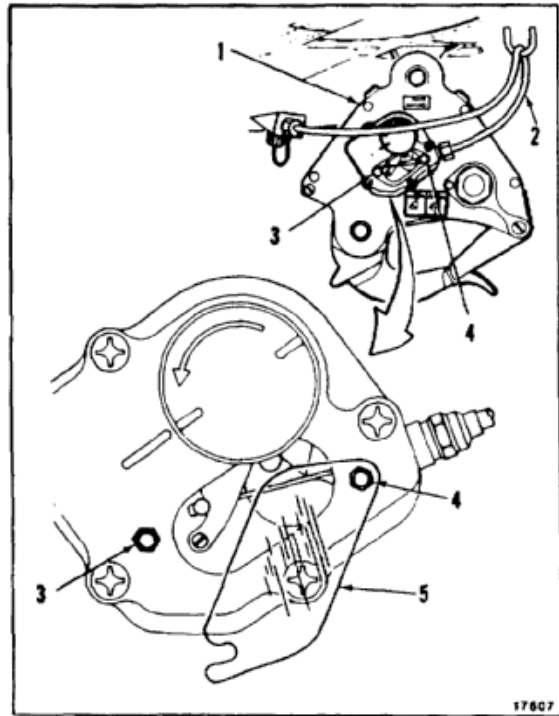

3. Manual release handle (6) should be set in vertical position. Ensure that manual release bellcrank (7) is against stop (8). Ensure that bellcrank (A) is against the eyebolt stop (B).

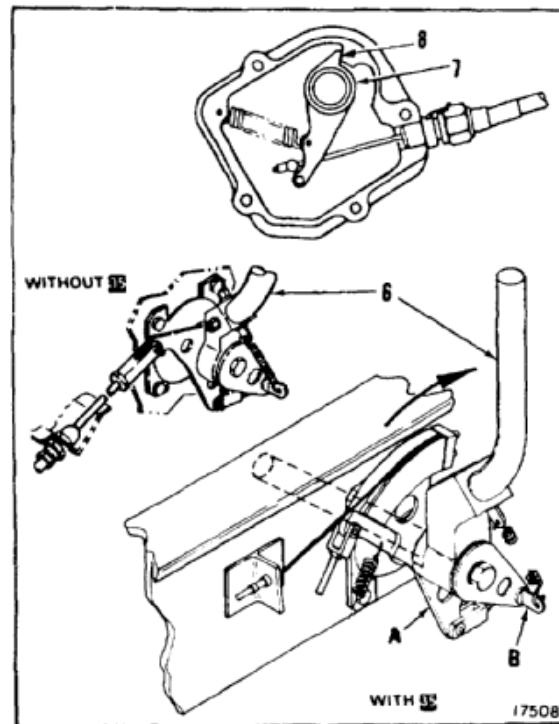



**16-35.1 ADJUST FORWARD OR AFT CARGO HOOK MANUAL RELEASE CABLE (Continued)**

16-35.1

4. Check clearance between ball end (9) and surface 'X' of release arm (10) at each cargo hook. Clearance shall be **0.00 to 0.20 inch**.

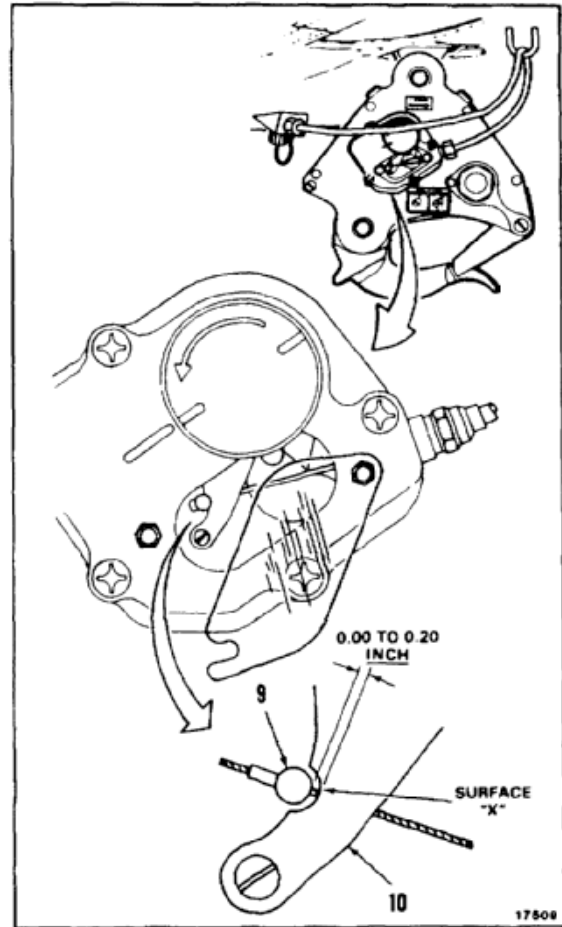

5. If gap is not within limits, remove lockwire, loosen locknut (11), and adjust cable clevis (12) at bellcrank (13).
6. Check for proper thread engagement at clevis (12). Minimum engagement is cable threaded end visible through witness hole in clevis.
7. Tighten locknut (11) against clevis (12). Lockwire locknut and clevis together. Use lockwire (E231).

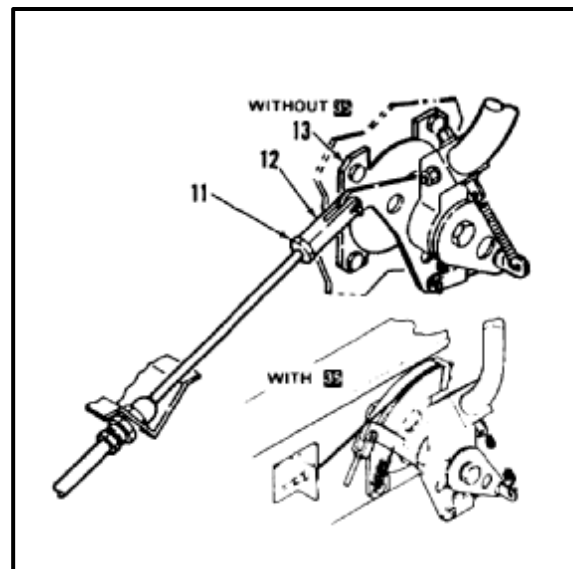

8. Position window (5) on retaining bolt (4).
9. Torque bolts (3 and 4) to **40 inch-pounds**. Lockwire bolts, cable adapter (14) and nut (15) together. Use lockwire (E231).

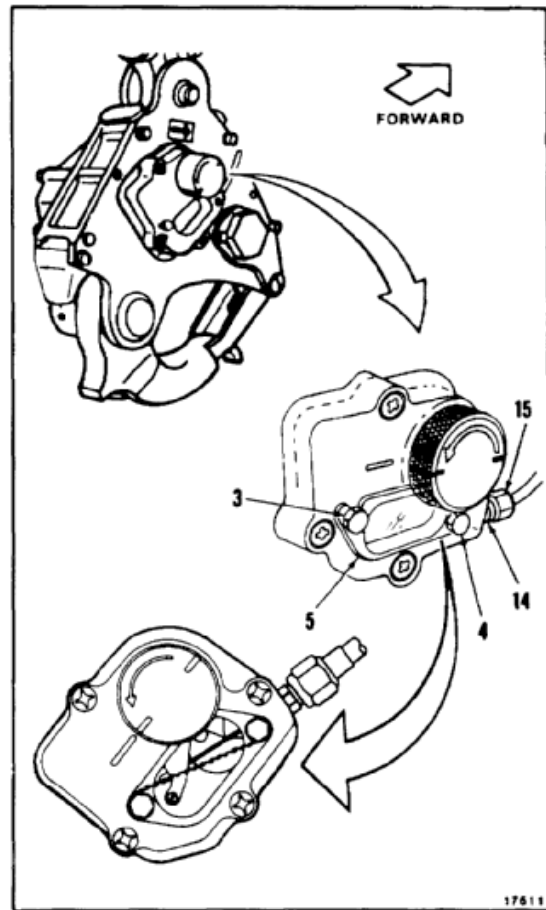
**FOLLOW-ON MAINTENANCE:**

None

END OF TASK

16-194

INITIAL SETUP

**Applicable Configurations:**

All

**Tools:**

Aircraft Mechanic's Tool Kit, NSN 51 80-00-323-4692

**Materials:**

None

**Personnel Required:**

Medium Helicopter Repairer

**Equipment Condition:**

- Battery Disconnected (Task 1-39)
- Electrical Power Off
- Hydraulic Power Off
- Center Hook Access Panel Opened (Task 2-2)

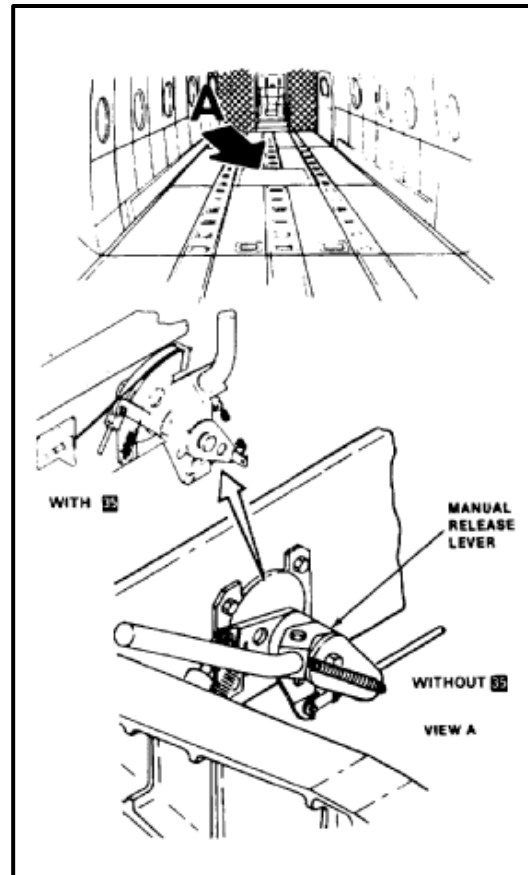

1. Move handle (1) from stowed position to straight up position.
2. Remove spring (2) from eyebolts (3 and 4).

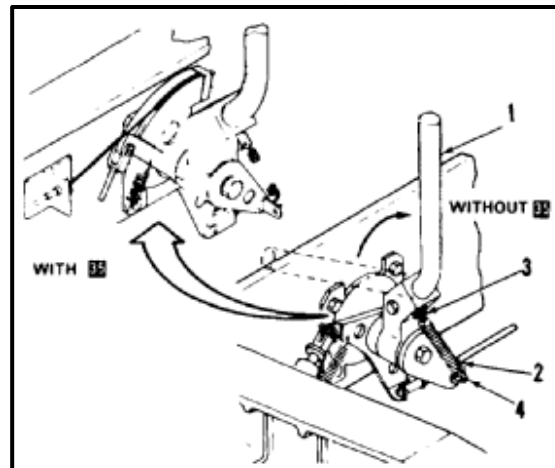

3. Remove lockwire and remove bolt (5) and washer (6).
4. Rotate retainer (7) clockwise to clear lever (8).

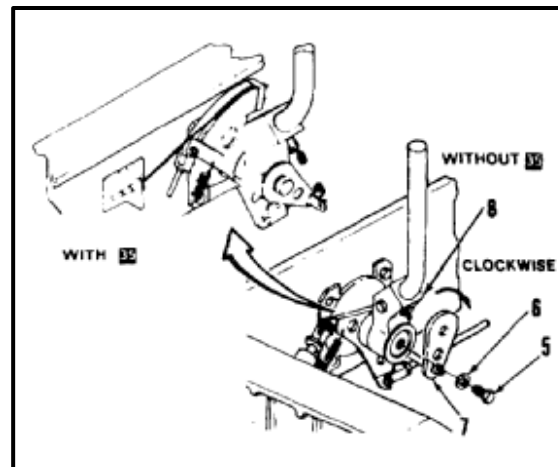

5. Remove lever (8) from mount (9).
6. Remove eyebolt (3), washer (10), and nut (11) from lever (8).
7. Remove bolt (12), washer (13), nut (14), and handle (1) from lever (8).

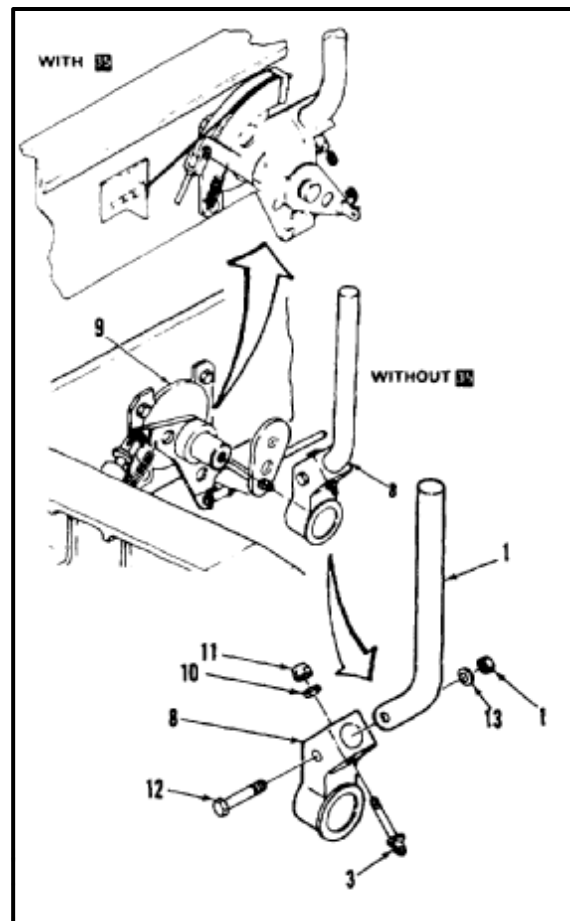

**FOLLOW-ON MAINTENANCE:**

None

END OF TASK

## INITIAL SETUP

**Applicable Configurations:**Without **35****Tools:**

Aircraft Mechanic's Tool Kit, NSN 5180-00-323-4692

**Materials:**

None

**Personnel Required:**

Medium Helicopter Repairer

**Equipment Condition:**

Battery Disconnected (Task 1-39)  
 Electrical Power Off  
 Hydraulic Power Off  
 Center Hook Access Panel Opened (Task 2-2)  
 Manual Release Lever Removed Task 16-36)

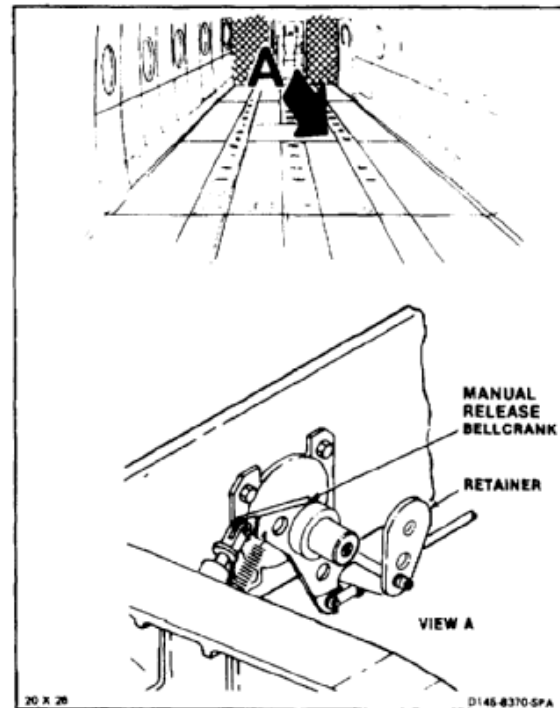

1. Remove spring (1) from manual release bellcrank (2).
2. Remove cotter pin (3), pin (4), washers (5), and forward release cable (6) from bellcrank (2).
3. Remove cotter pin (7), pin (8), washer (9), and aft release cable (10) from bellcrank (2).

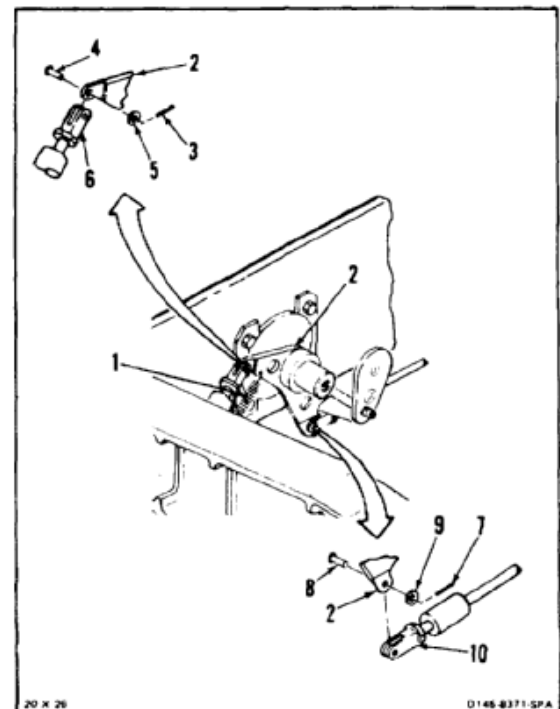

4. Remove bellcrank (2) from mount (9).

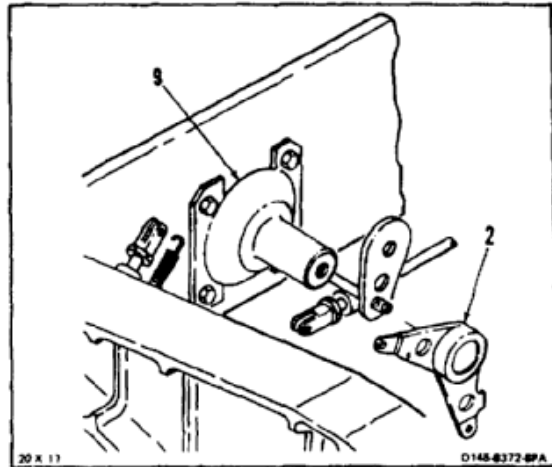

**FOLLOW-ON MAINTENANCE:**

None

END OF TASK

**16-37.1 REMOVE CARGO HOOK MANUAL RELEASE BELLCRANK**

16-37.1

**INITIAL SETUP****Applicable Configurations:**With **35****Tools:**

Aircraft Mechanic's Tool Kit, NSN 51 80-00-323-4692

**Materials:**

None

**Personnel Required:**

Medium Helicopter Repairer

**Equipment Condition:**

Battery Disconnected (Task 1-39)  
 Electrical Power Off  
 Hydraulic Power Off  
 Center Hook Access Panel Opened (Task 2-2)  
 Manual Release Lever Removed (Task 16-36)

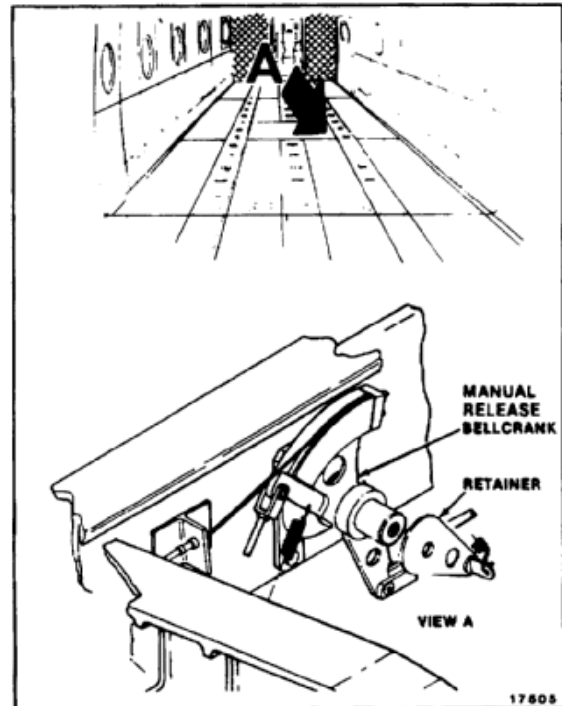

1. Remove spring (1) from manual release bellcrank (2).
2. Remove cotter pin (3), pin (4), washer (5), and forward release cable (6) from bellcrank (2).
3. Remove cotter pin (7), pin (8), washer (9), and aft release cable (10) from bellcrank (2).
4. Remove lockwire from bolt (11) and jam nuts (12 and 13).
5. Remove bolt (11) and washer (14).
6. Hold jam nut (13). Loosen jam nut (12).
7. Remove center release cable (15) together with retainer (16) from bellcrank (2).

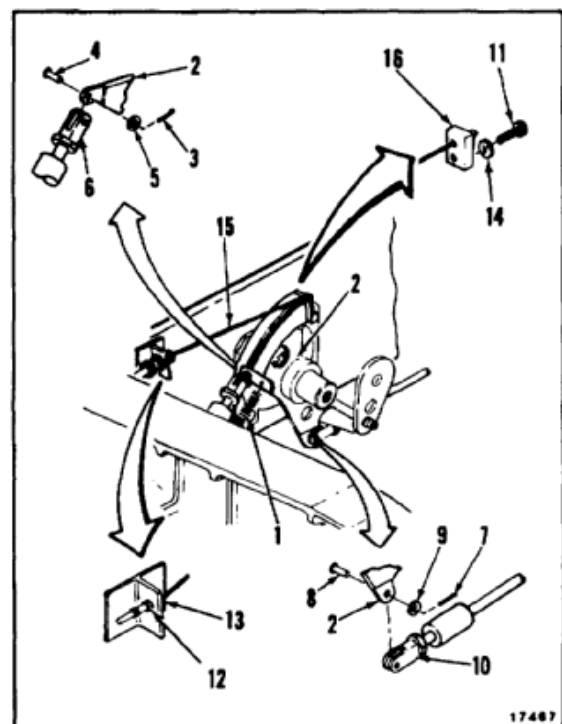

8. Remove bellcrank (2) from mount (17).

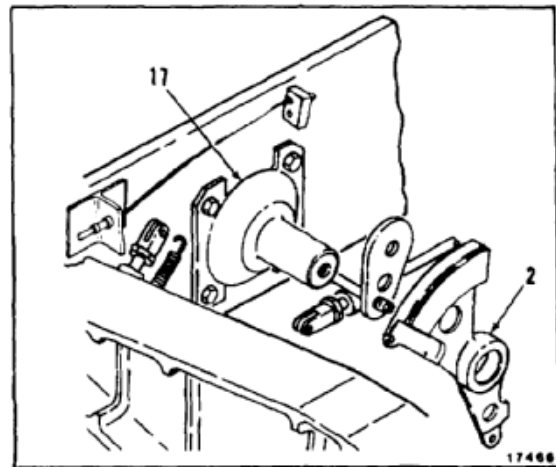

**FOLLOW-ON MAINTENANCE:**

None

END OF TASK



INITIAL SETUP

**Applicable Configurations:**

All

**Tools:**

Aircraft Mechanic's Tool Kit, NSN 51 80-00-323-4692

**Materials:**

None

**Personnel Required:**

Medium Helicopter Repairer

**Equipment Condition:**

- Battery Disconnected (Task 1-39)
- Electrical Power Off
- Hydraulic Power Off
- Center Hook Access Panel Opened (Task 2-2)
- Manual Release Lever Removed (Task 16-36)
- Manual Release Bellcrank Removed (Tasks 16-37 Without **35**, 16-37.1 With **35**)

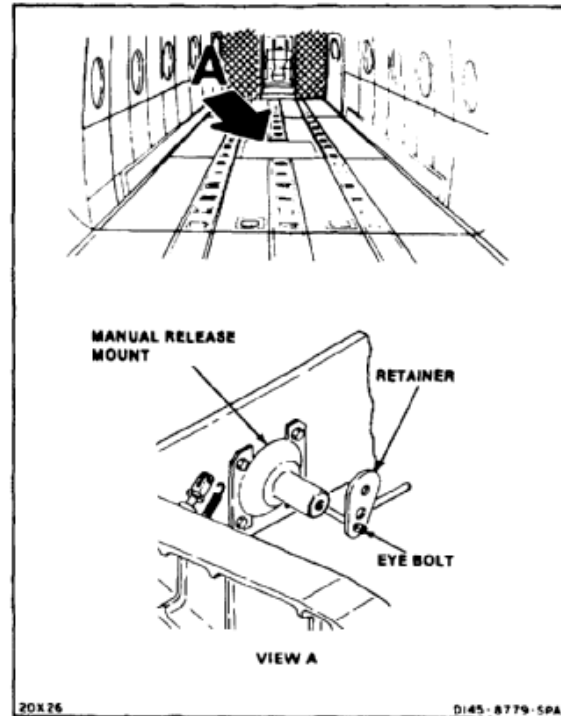

1. Remove eyebolt (1), washer (2), spacer (2.1), and retainer (3).

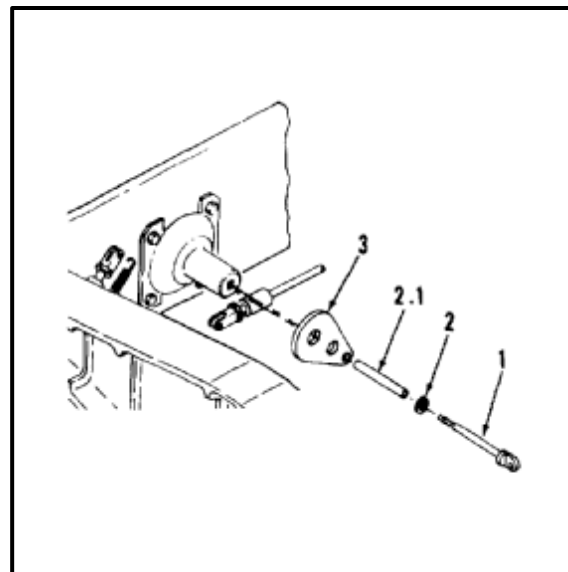

2. Remove three bolts (4), washers (5), and manual release mount (6).

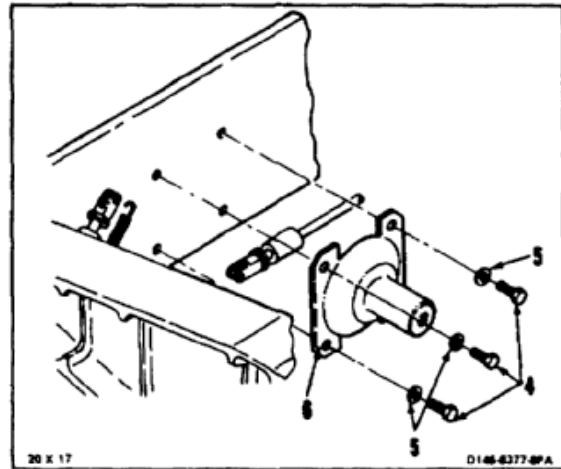
***FOLLOW-ON MAINTENANCE:***

None

END OF TASK

**16-202**

INITIAL SETUP

**Applicable Configurations:**

All

**Tools:**

Aircraft Mechanic's Tool Kit, NSN 51 80-00-323-4692

**Materials:**

None

**Personnel Required:**

Medium Helicopter Repairer  
Inspector

**References:**

TM 55-1520-240-23P

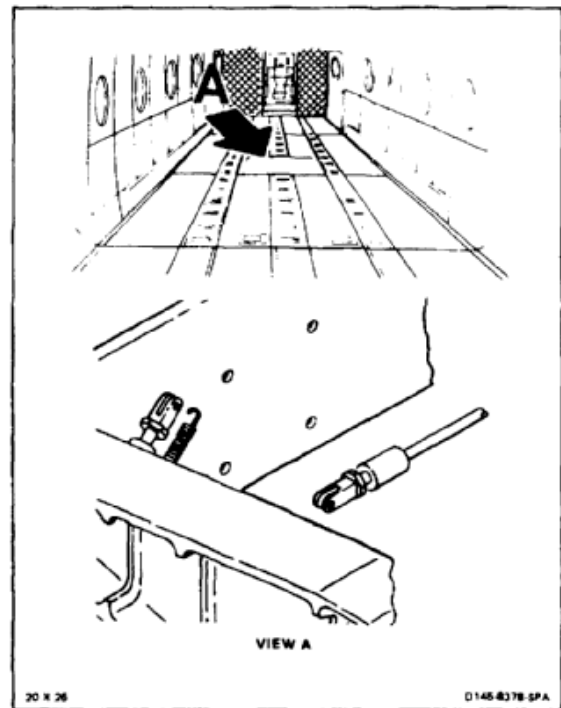

1. Align holes in manual release mount (1) and structure (2). Install three bolts (3) and washers (4).

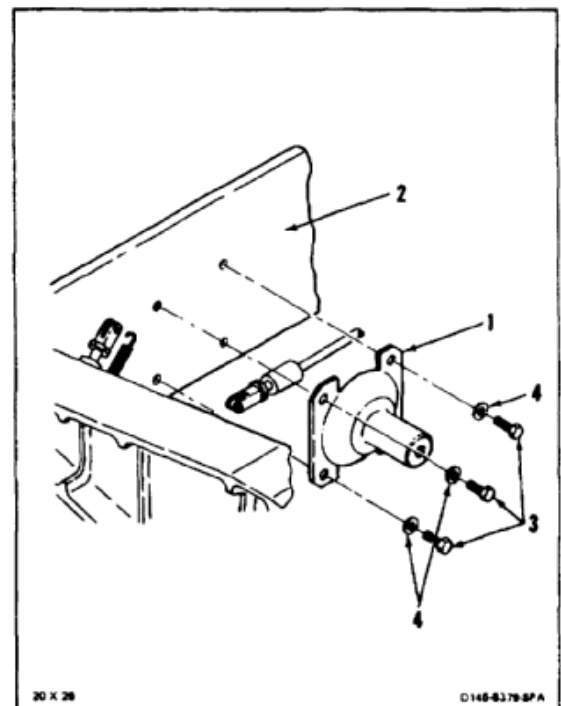

2. Loosely install retainer (5), washer (6), spacer (6.1), and eyebolt (7).

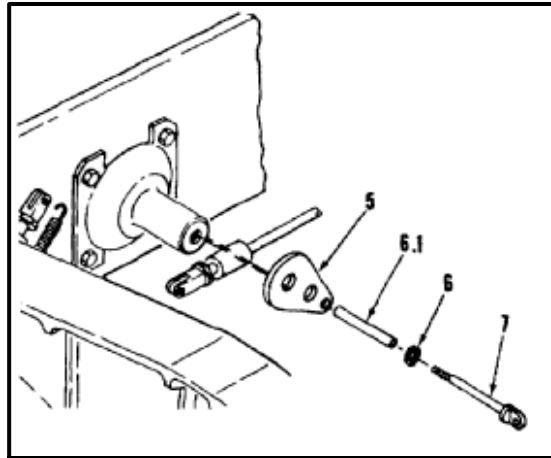
**INSPECT****FOLLOW-ON MAINTENANCE:**

- Install manual release bellcrank (Tasks 16-40 without **35**, 16-40.1 with **35**).
- Install manual release lever (Task 16-41).
- Close center hook access panel (Task 2-2).

END OF TASK

INITIAL SETUP

**Applicable Configurations:**

Without **35**

**Tools:**

Aircraft Mechanic's Tool Kit, NSN 51 80-00-323-4692

**Materials:**

None

**Parts:**

Cotter Pins

**Personnel Required:**

Medium Helicopter Repairer  
Inspector

**References:**

TM 55-1520-240-23P

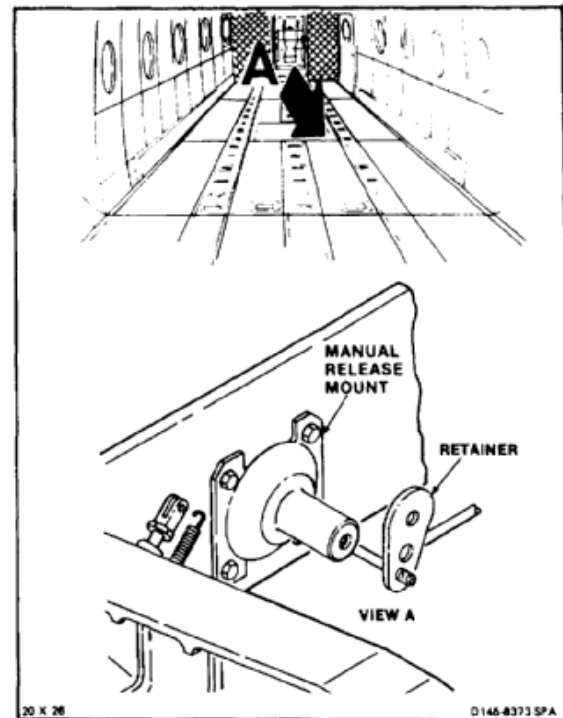

1. Position manual release bellcrank (1) on mount (2).
2. Align hole in aft release cable (3) and bellcrank (1). Install pin (4), washer (5), and cotter pin (6).
3. Align hole in forward release cable (7) and bellcrank (1). Install pin (8), washer (9), and cotter pin (10).

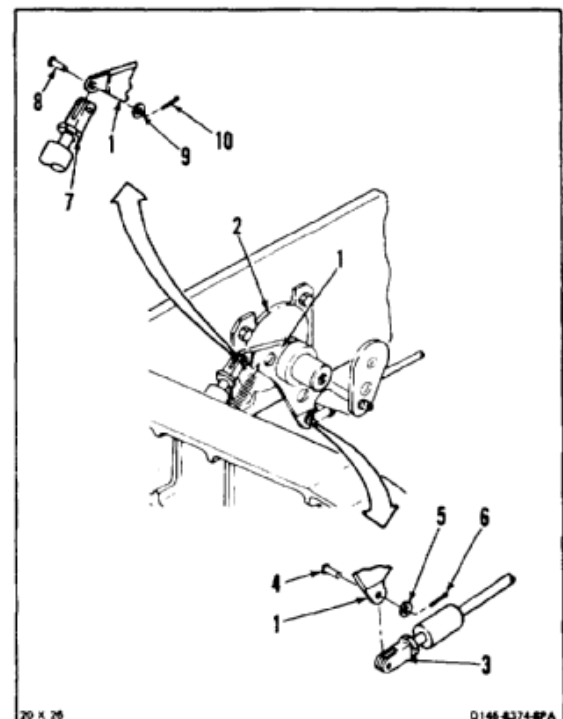

4. Install spring (11) in bellcrank (1).

**INSPECT**

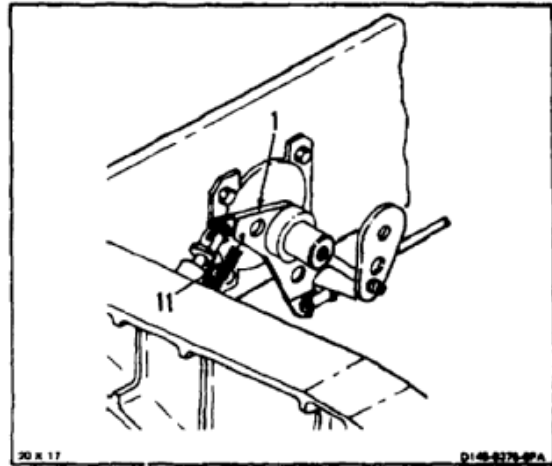

**FOLLOW-ON MAINTENANCE:**

Install manual release lever (Task 16-41).

END OF TASK

**16-40.1 INSTALL CARGO HOOK MANUAL RELEASE BELLCRANK**

16-40.1

**INITIAL SETUP****Applicable Configurations:**With **35****Tools:**

Aircraft Mechanic's Tool Kit, NSN 51 80-00-323-4692

**Materials:**

Lockwire (E231)

**Parts:**

Cotter Pins

**Personnel Required:**Medium Helicopter Repairer  
Inspector**References:**

TM 55-1520-240-23P

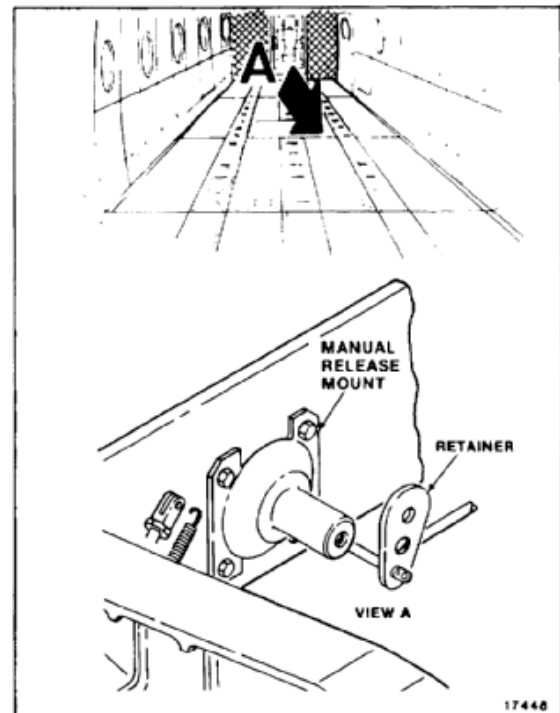

1. Position manual release bellcrank (1) on mount (2).
2. Align hole in aft release cable (3) and bellcrank (1). Install pin (4), washer (5), and cotter pin (6).
3. Align hole in forward release cable (7) and bellcrank (1). Install pin (8), washer (9), and cotter pin (10).
4. Route cable (11) past bellcrank (1). Install bolt (12) and washer (13) securing retainer (14). Lockwire bolt with lockwire (E231).
5. Check that cable (11) protrudes past bracket (15) **0.70 to 0.75 inch**. This dimension is for initial installation and may change during final adjustment.
6. Hold jam nut (16). Tighten jam nut (17). Lockwire jam nuts together with lockwire (E231).

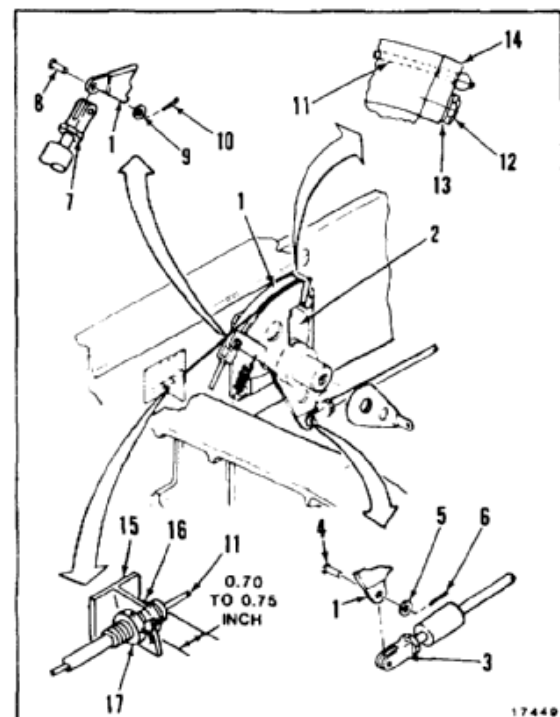

7. Install spring (18) in bellcrank (1).

**INSPECT**

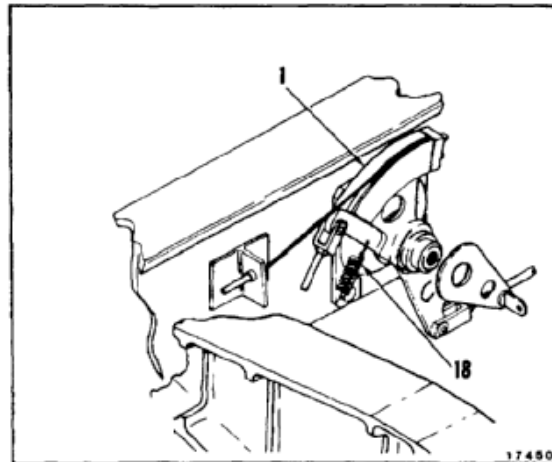

**FOLLOW-ON MAINTENANCE:**

- Install manual release lever (Task 16-41).
- Adjust center cargo hook manual release cable (Task 16-3.5).

END OF TASK



INITIAL SETUP

**Applicable Configurations:**

All

**Tools:**

Aircraft Mechanic's Tool Kit, NSN 51 80-00-323-4692

**Materials:**

Lockwire (E231)

**Personnel Required:**

Medium Helicopter Repairer  
Inspector

**References:**

TM 55-1520-240-23P

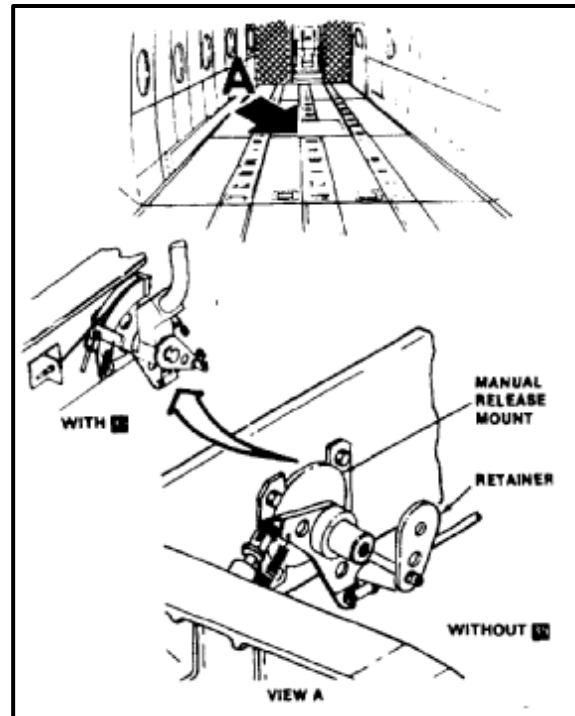

1. Install handle (1) in lever (2).
2. Align holes in handle (1) and lever (2). Install bolt (3), washer (4), and nut (5). Install eyebolt (6), washer (7), and nut (8).
3. Install lever (2) on mount (9).

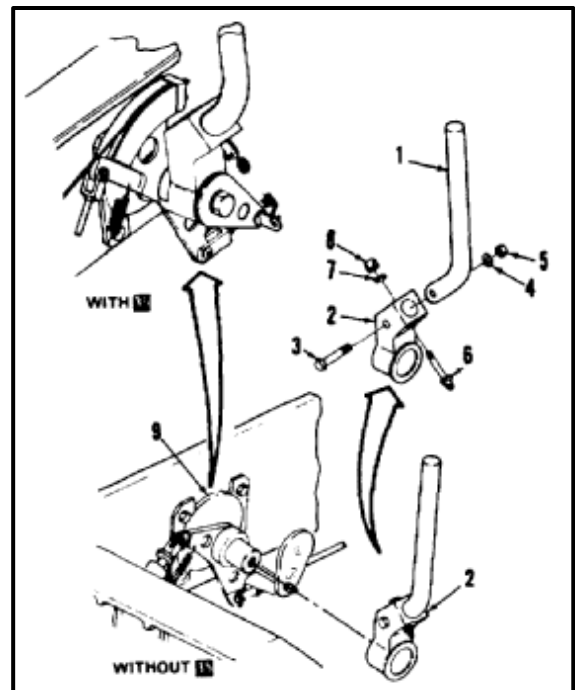

4. Align hole in retainer (10) and mount (9). Install bolt (11) and washer (12).
5. Lockwire bolt (11). Use lockwire (E231).

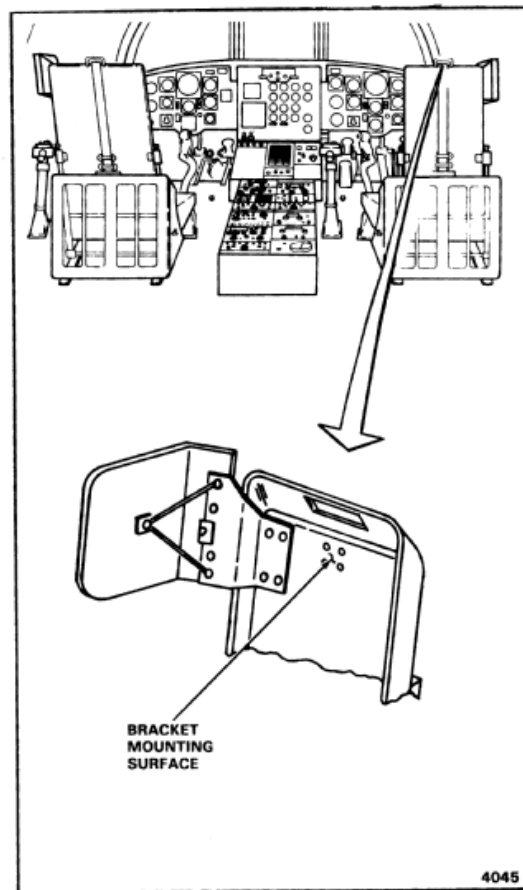

6. Deleted.
7. Install spring (14) in eyebolts (6 and 13).

**INSPECT**

8. Move handle (1) to stowed position.

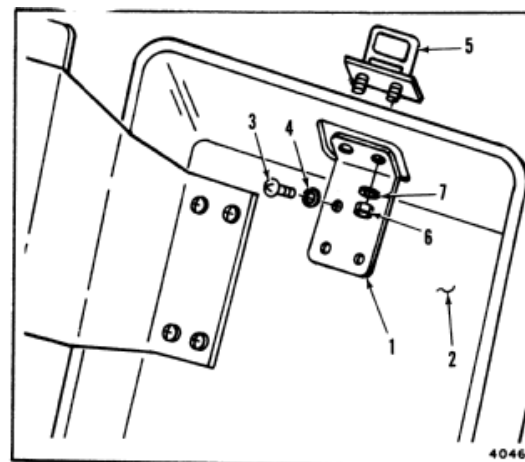

**FOLLOW-ON MAINTENANCE:**

Close center hook access panel (Task 2-2).

END OF TASK

**SECTION III**  
**PARATROOP AND CARGO DROP EQUIPMENT DESCRIPTION AND**  
**OPERATION**

Paratroop and cargo drop equipment is used to ensure that the parachute opens when troops or cargo are dropped out the aft end of the helicopter. The equipment consists of an anchor cable, a retriever, and a quick-disconnect.

In use, the anchor cable is installed along the cabin ceiling from sta 120 to sta 594. Parachute static lines are hooked to the cable forward of the retriever.

The quick-disconnect is used to bring static lines into the helicopter after a mission. It can also be used to

bring in a paratrooper if the static line fouls or does not disengage. To use this feature, the helicopter winch cable must be routed as shown. The quick-disconnect is hooked to the link on the retriever and the winch cable is coupled to the quick-disconnect. The winch is operated to pull the retriever forward along the anchor cable, pulling in the static lines.

When not in use, the equipment is stowed in a stowage bag. The bag is mounted aft of the cabin door, behind the troop seat.

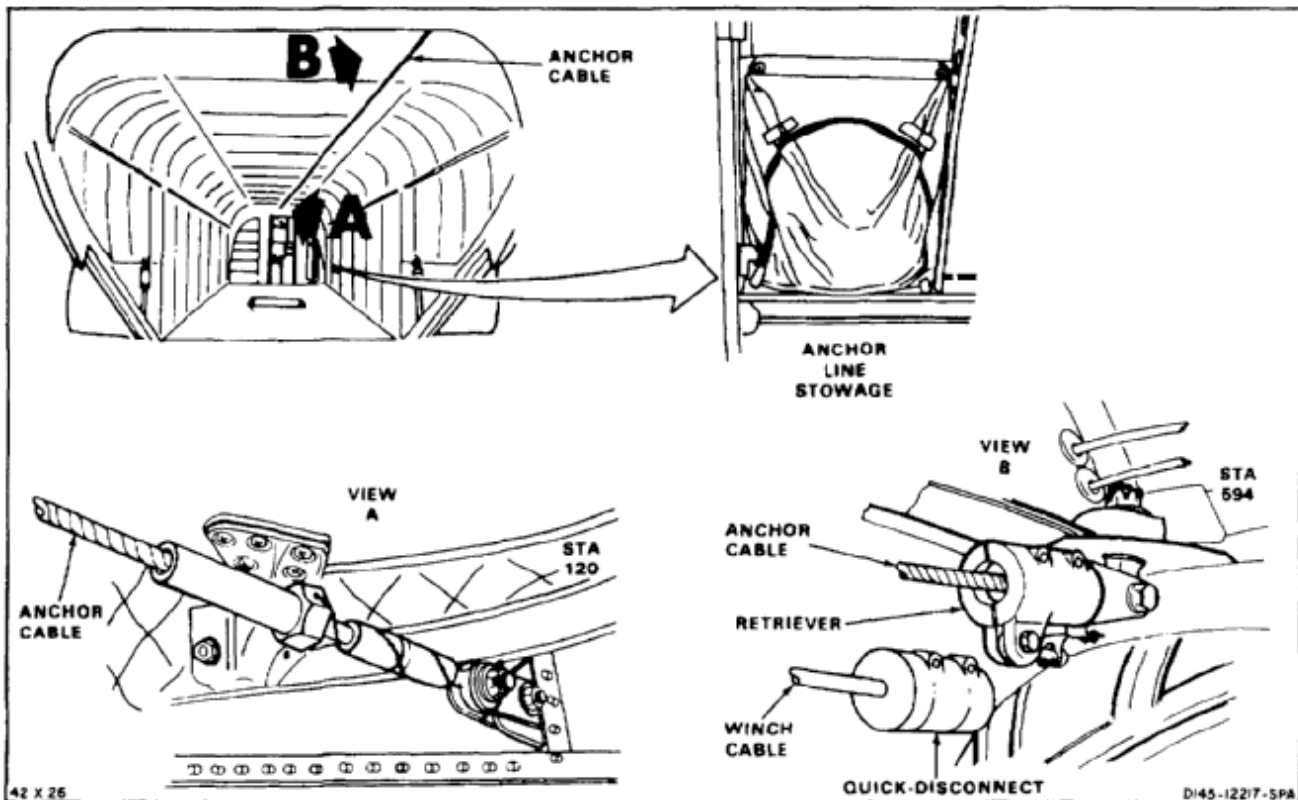

END OF TASK

**SECTION IV**  
**PARATROOP AND CARGO DROP EQUIPMENT**

## INITIAL SETUP

**Applicable Configurations:**

All

**Tools:**

None

**Materials:**

Cloth (E121)  
 Dry Cleaning Solvent (E162)  
 Wire Handling  
 Gloves (E185)

**Personnel Required:**

Medium Helicopter Repairer  
 Inspector

**Equipment Condition:**

Battery Disconnected (Task 1-39)  
 Electrical Power Off

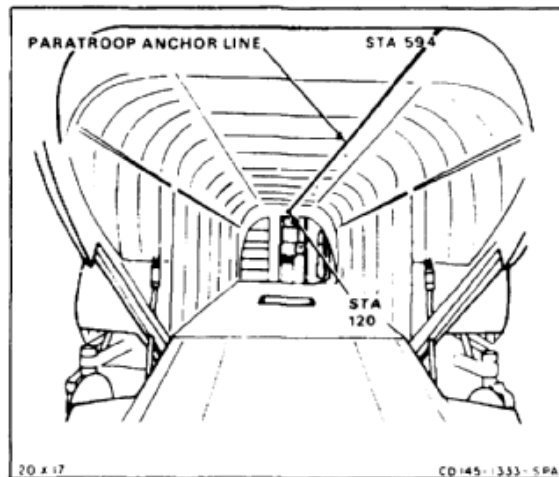
**INSPECT ANCHOR LINE**

1. Check retriever (1) and retriever stop (2). There shall be no cracks, corrosion, or broken stop handle flanges (3).
2. Check connector (4) and surrounding structure (5). There shall be no cracks or corrosion.

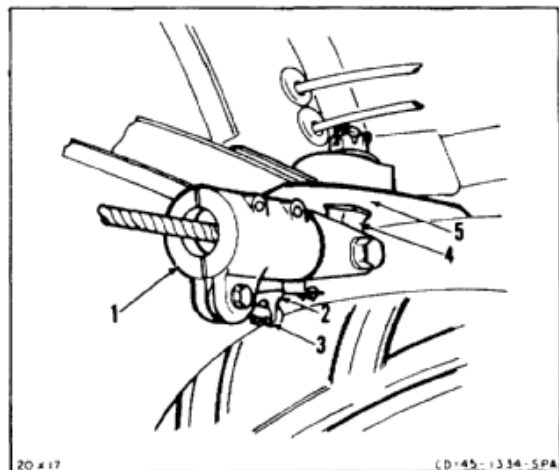

**16-43 INSPECT PARATROOP ANCHOR LINE (Continued)**

16-43

3. Check turnbuckle (6) and eyebolt (7). There shall be no cracks, corrosion, or broken lockwire.
4. Check attach fitting (8) and two links (9). There shall be no cracks and corrosion.

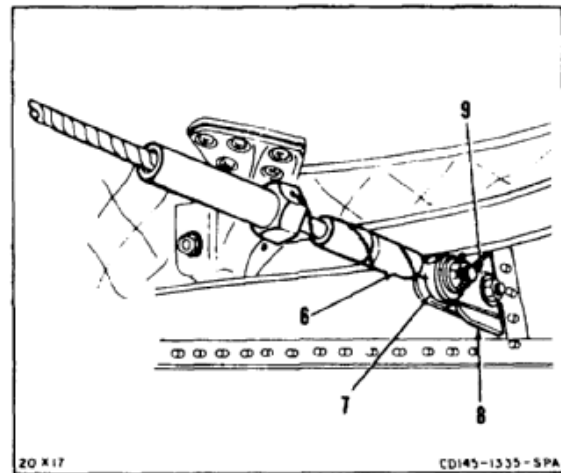
**INSPECT ANCHOR LINE CABLE****WARNING**

Dry cleaning solvent (E162) is flammable and toxic. It can irritate skin and cause burns. Use only in well-ventilated area away from heat and open flames. In case of contact, immediately flush skin or eyes with water for at least **15 minutes**. Get medical attention for eyes.

5. Clean wire rope (10) with solvent (E162) and cloth (E121). Wear gloves (E185). Gloves shall be worn for the remainder of this task.
6. Check wire rope (10) for broken wires by pulling clean dry cloth (E121) along wire rope (10). If cloth snags, there are broken wires. There shall be no more than four wires broken in any **1 inch** length.
7. Check wire rope (10) for kinks. There shall be no kinks.

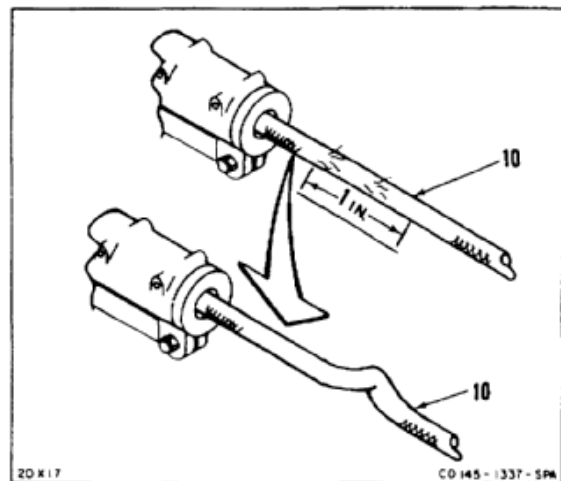
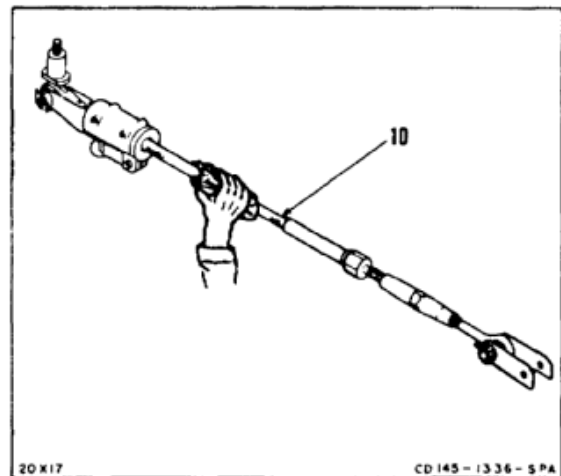
**FOLLOW-ON MAINTENANCE:**

None

END OF TASK

16-215

INITIAL SETUP

**Applicable Configurations:**

All

**Tools:**

Aircraft Mechanic's Tool Kit, NSN 5180-00-323-4692

**Materials:**

None

**Personnel Required:**

Medium Helicopter Repairer

**Equipment Condition:**

Battery Disconnected (Task 1-39)  
Electrical Power Off

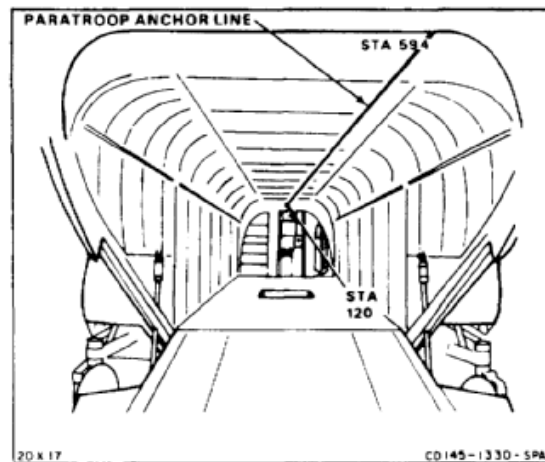

1. Remove lockwire on turnbuckle (1).
2. Turn turnbuckle (1) to loosen anchor line (2).
3. Remove nut (3), two washers (4), and bolt (5).
4. Remove anchor line (2) from connect link (6) on fitting (7).

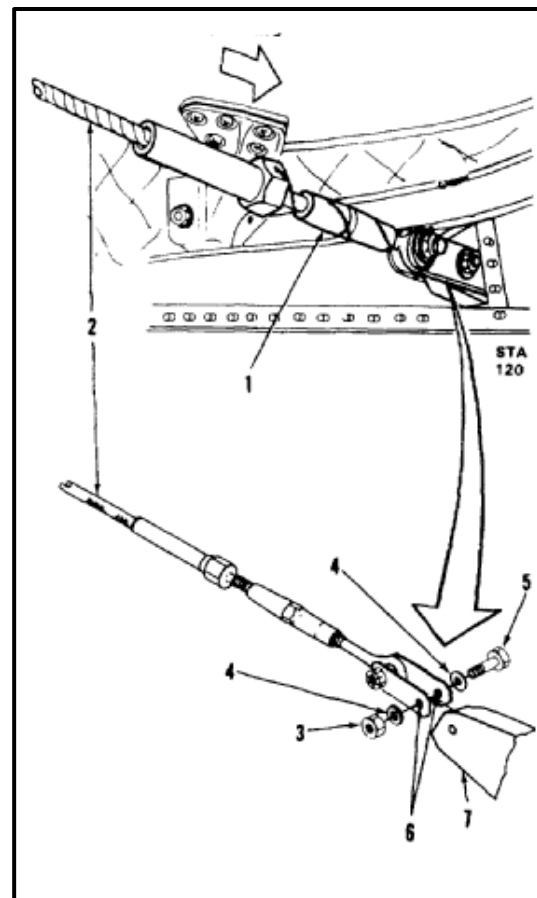



**16-44 REMOVE PARATROOP ANCHOR LINE ASSEMBLY (Continued)****16-44**

5. Remove cotter pin (8), nut (9), washers (10), and bolt (11).
6. Remove anchor line (2) from fitting (12).

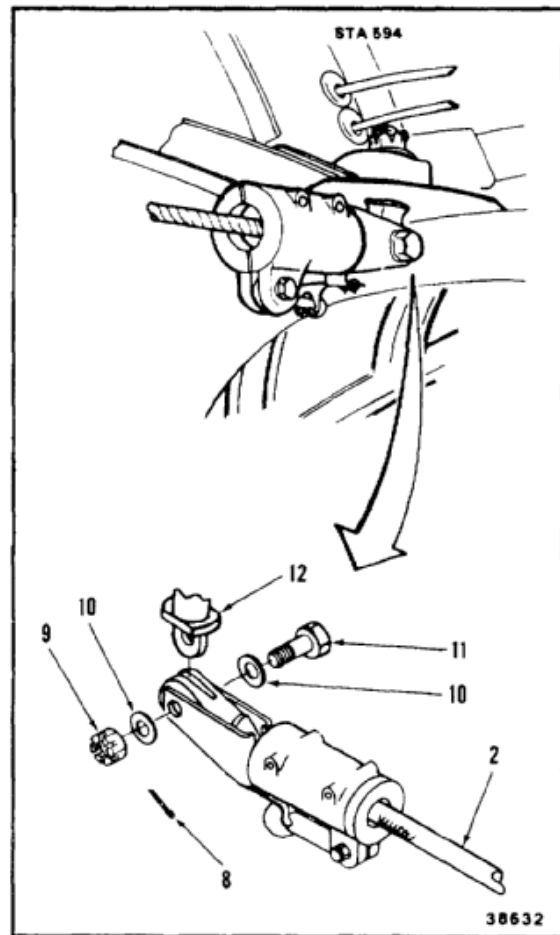
***FOLLOW-ON MAINTENANCE:***

None

END OF TASK

INITIAL SETUP

**Applicable Configurations:**

All

**Tools:**

Aircraft Mechanic's Tool Kit, NSN 5180-00-323-4692

**Materials:**

None

**Personnel Required:**

Medium Helicopter Repairer

**Equipment Condition:**

Off Helicopter Task

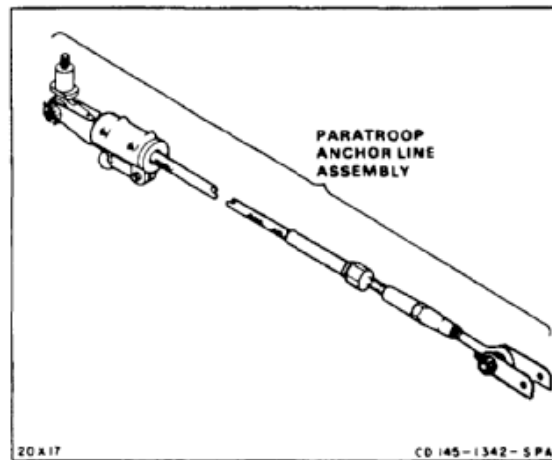

1. Remove cotter pin (1), nut (2), two washers (3), and bolt (4).
2. Separate connector (5) from clevis (6).
3. Separate retriever stop (7) from arm (8).

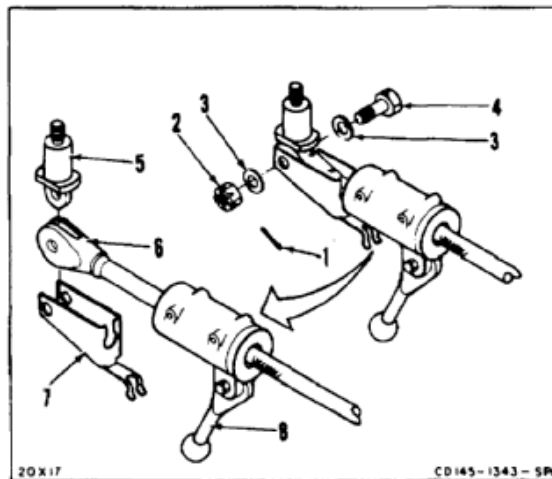

4. Remove cotter pin (9), nut (10), four washers (11), and bolt (12).
5. Remove arm (8) and two bushings (13).
6. Remove two pins (14) from retriever (15).
7. Remove clevis (6).

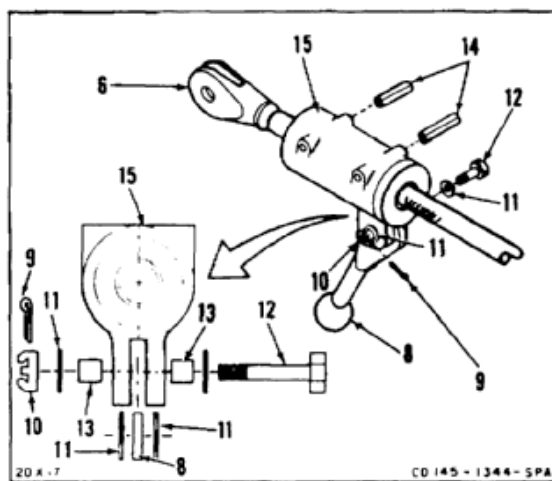

**16-45 DISASSEMBLE PARATROOP ANCHOR LINE ASSEMBLY (Continued)****16-45**

8. Remove cotter pin (16), nut (17), two washers (18), and bolt (19).
9. Remove two links (20) from eyebolt (21).
10. Remove eyebolt (21) from turnbuckle (22).
11. Remove turnbuckle (22) from stud (23).

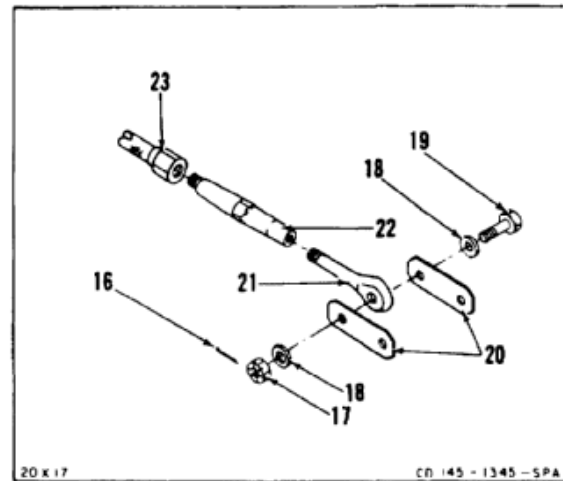
***FOLLOW-ON MAINTENANCE:***

None

END OF TASK

INITIAL SETUP

**Applicable Configurations:**

All

**Tools:**

Aircraft Mechanic's Tool Kit, NSN 5180-00-323-4692

**Materials:**

None

**Parts:**

Cotter Pins  
Spring Pins

**Personnel Required:**

Medium Helicopter Repairer  
Inspector

**References:**

TM 55-1520-240-23P

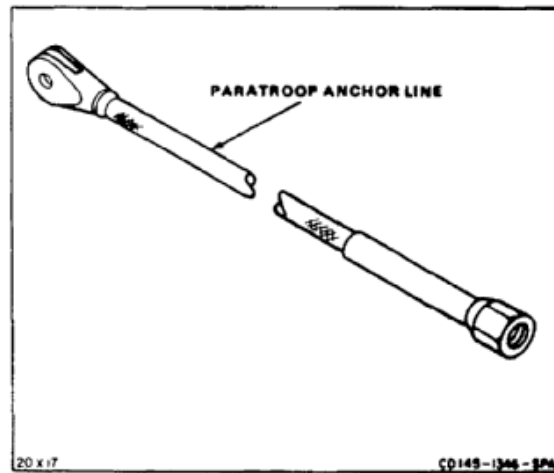

1. Install eyebolt (1) in turnbuckle (2).
2. Install turnbuckle (2) in terminal stud (3).
3. Position two links (4) on eyebolt (1). Install two washers (5), bolt (6), nut (7), and cotter pin (8).

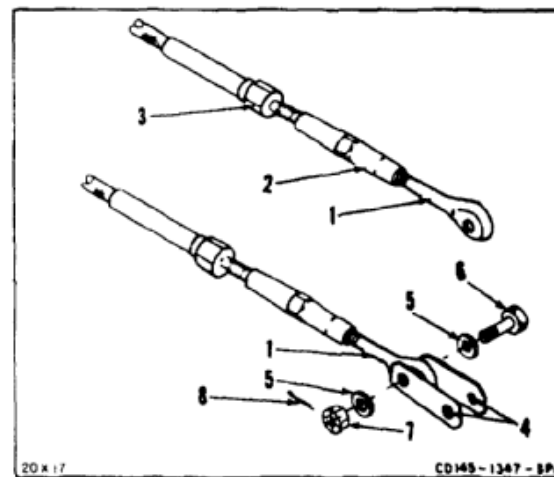

4. Position retriever (9) on clevis (10). Install two spring pins (11) in retriever.
5. Install two bushings (12) in retriever (9).
6. Install arm (13) with four washers (14), bolt (15), nut (16), and cotter pin (17).

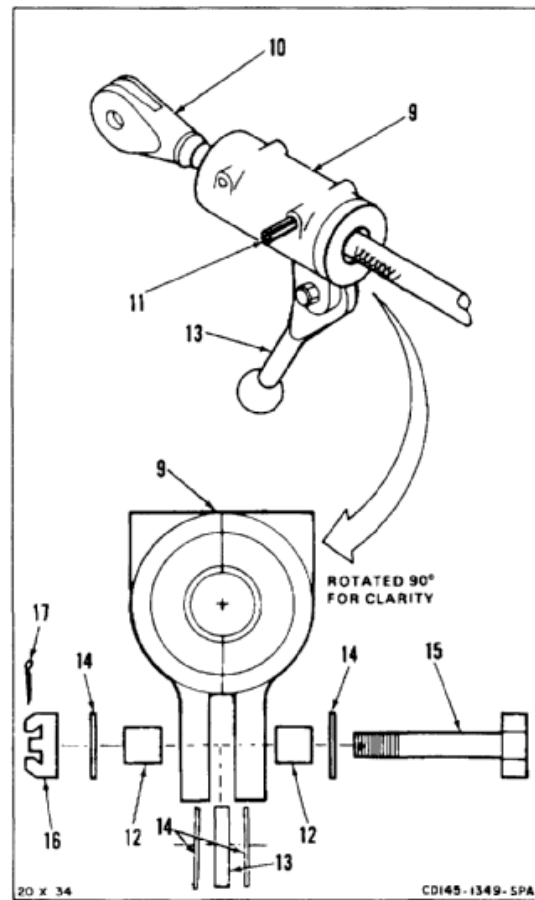

7. Position connector (18) in clevis (10). Position retriever stop (19) on clevis. Align holes in connector and clevis.
8. Install two washers (20), bolt (21), nut (22), and cotter pin (23).
9. Set arm (13) in retriever clip (24).

**INSPECT**

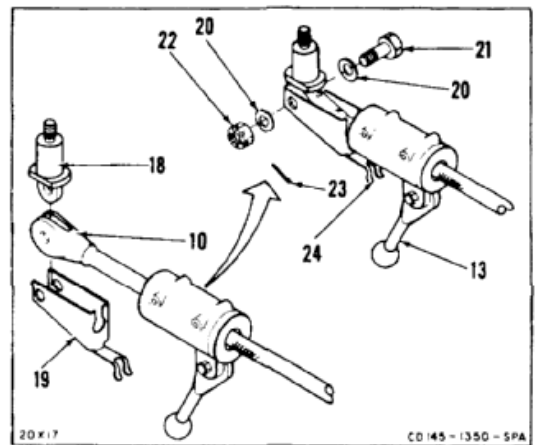

**FOLLOW-ON MAINTENANCE:**

None

END OF TASK

INITIAL SETUP

**Applicable Configurations:**

All

**Tools:**

Aircraft Mechanic's Tool Kit, NSN 5180-00-323-4692

**Materials:**

Lockwire (E230)

**Parts:**

Cotter Pin

**Personnel Required:**

Medium Helicopter Repairer  
Inspector

**References:**

TM 55-1520-240-23P

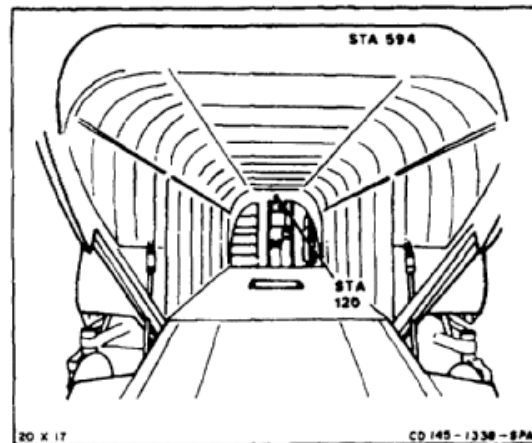

1. Install connector (1) with cable (2) in structure (3). Install washer (4), nut (5), and cotter pin (6).

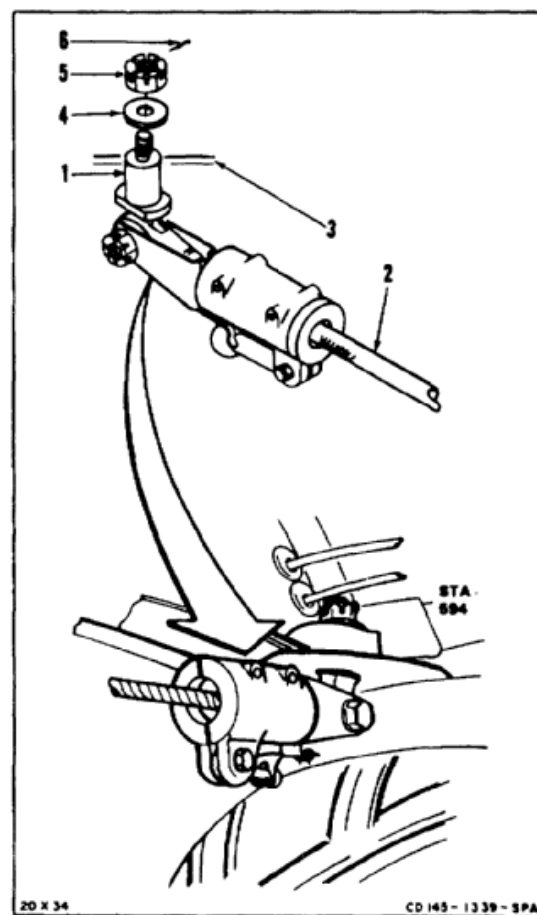

**NOTE**

Make sure there is enough slack in anchor line wire rope to install bolt. If not, loosen turnbuckle.

2. Install connect links (7) to fitting (8). Install two washers (9), bolt (10), and nut (11).
3. Tighten wire rope (2) with turnbuckle (12). Do not let wire rope sag more than **6 inches**.
4. Install lockwire (E230) on turnbuckle (12).

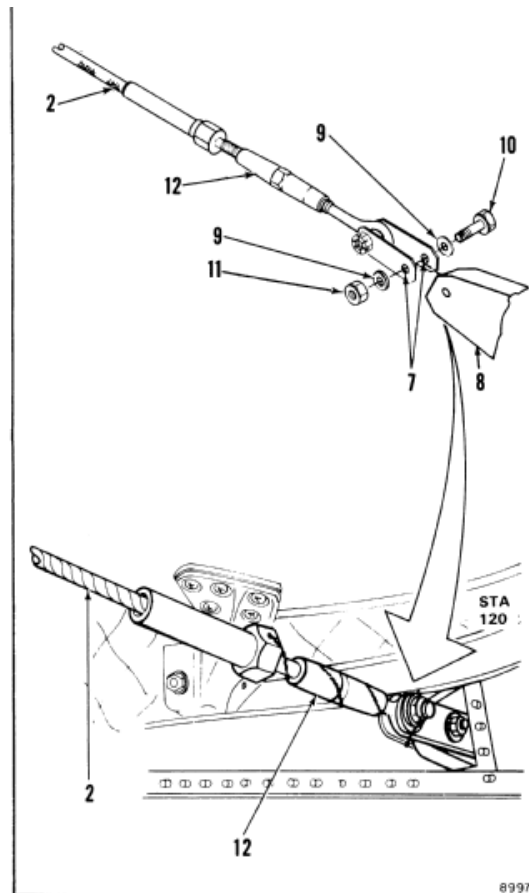
**INSPECT****FOLLOW-ON MAINTENANCE:**

None

END OF TASK





**SECTION V**  
**FLARE DISPENSER SYSTEM DESCRIPTION AND THEORY OF OPERATION**

**DESCRIPTION**

The Flare Dispenser System is a countermeasure to infra-red guided heat-seeking missiles when the helicopter is airborne. The heart of the system is a flare dispenser assembly, consisting of a dispenser, electronics module, and payload module. Other components are a remote test panel, timer, cockpit control panel, six firing switches, and a safety relay. The system is operated by **28 vdc**.

When a missile launch is detected, either by sight or radar warning, the system is activated by pressing one of the six firing switches. There are four firing switches in the cabin and one on each cyclic stick control grip. Each time any of the firing switches is pressed, the system will fire a flare. If the switch is held down, the timer will cause a flare to be fired every **2.5 seconds**.

The payload module has provisions for 30 flares. A digital counter on the dispenser control panel indicates the number of flares remaining. The panel also has a RIPPLE FIRE switch, which jettisons all remaining flares in case of an emergency, and an ARM/SAFE switch to arm the system in flight.

The electronics module programs the number of flares to fire on each firing order. It also has a safety switch to prevent accidental firing. This switch is activated by a safety pin which is removed before flight and installed immediately after landing.

When the helicopter is on the ground, a proximity switch on the aft landing gear disarms the system by deenergizing a safety relay in the circuit. The NORMAL/BYPASS switch stays in the NORMAL position until moved to BYPASS for ground testing. In this mode, the switch bypasses the landing gear switch to energize the safety relay. Two caution lights on the panel indicate a READY TO FIRE status and the landing gear switch status.

The CHAFF utility mode of the system is not used on the CH47 helicopter.

**THEORY OF OPERATION**

Power for the flare dispenser system is provided by **28 vdc** from the No. 1 dc bus through the CHAFF circuit breaker on the No. 1 power distribution panel. The system is readied for operation by setting the toggle switch on the cockpit control panel to ARM.

If the helicopter is on the ground, safety relay 147K1 will be held deenergized by landing gear switch 148K2 and the system will remain disabled. When the helicopter is in the air, the switch closes, energizing the relay and allowing power to flow to the remote test panel and the cockpit control panel. With the safety pin removed from the electronics module and the test panel switch at ARM, the timer circuit is armed and lights on the test panel come on to indicate that the landing gear switch is closed and the system is armed and ready to fire.

When a cockpit or cabin firing switch is pressed, a **28-volt** firing signal is routed through the timer to the flare dispenser. A flare from the payload module is fired and the READY TO FIRE light on the remote test panel goes out. A flare sensor in the dispenser checks for a successful firing by detecting the heat generated during ignition and relaying the information to a flare detector in the electronic module. If no such information is received, meaning that a flare was not successfully fired, the module automatically fires another flare. If the second flare also fails, a third flare is ejected. If the third fails, the automatic sequence stops until one of the firing switches is pressed again.

With the successful firing of a flare, a **2.5 second** delay is imposed by the timer before another flare can be fired. Readiness is signalled by the READY TO FIRE light on the remote test panel coming on. With that, the sequence may be repeated until all 30 flares have been fired.

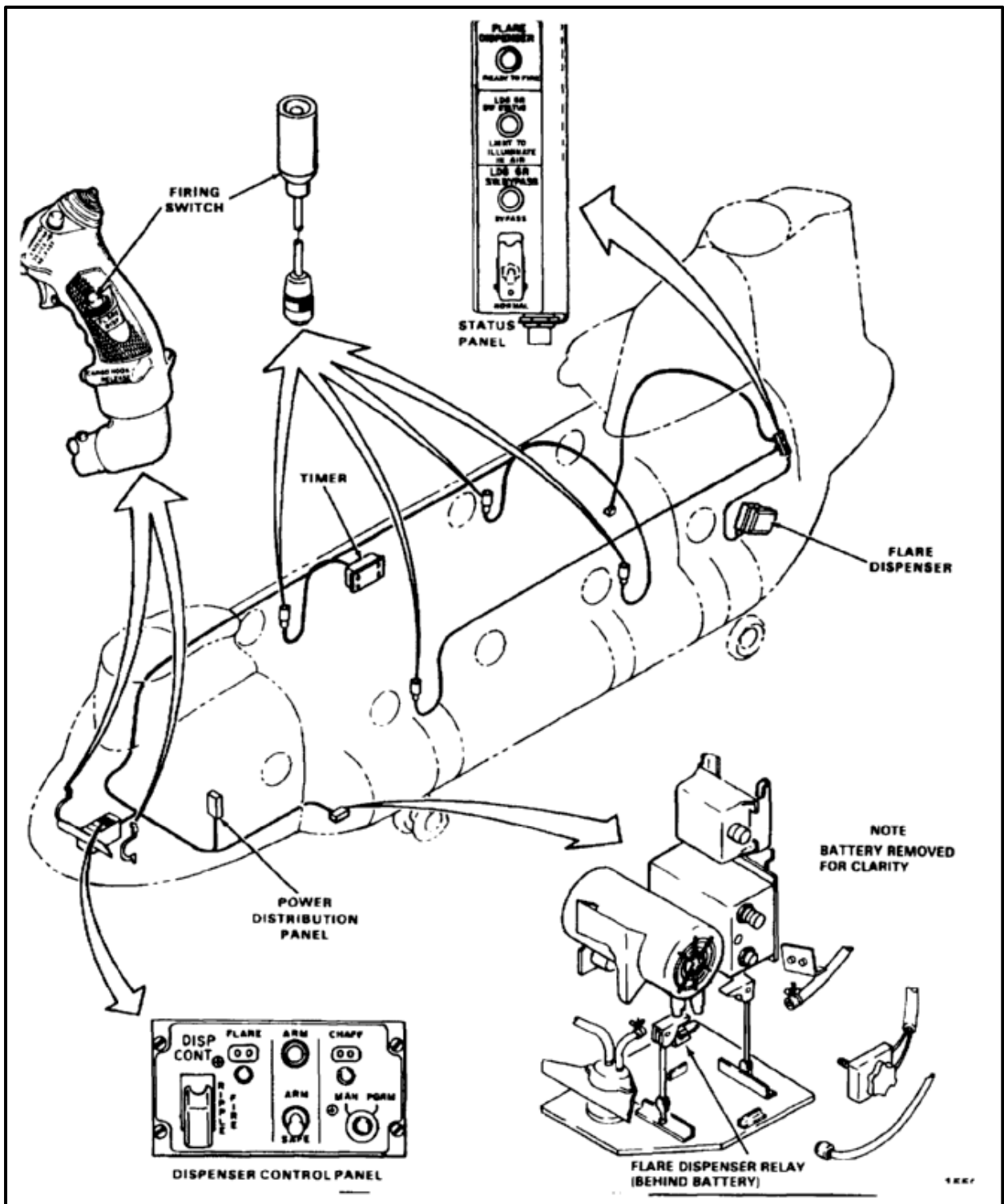

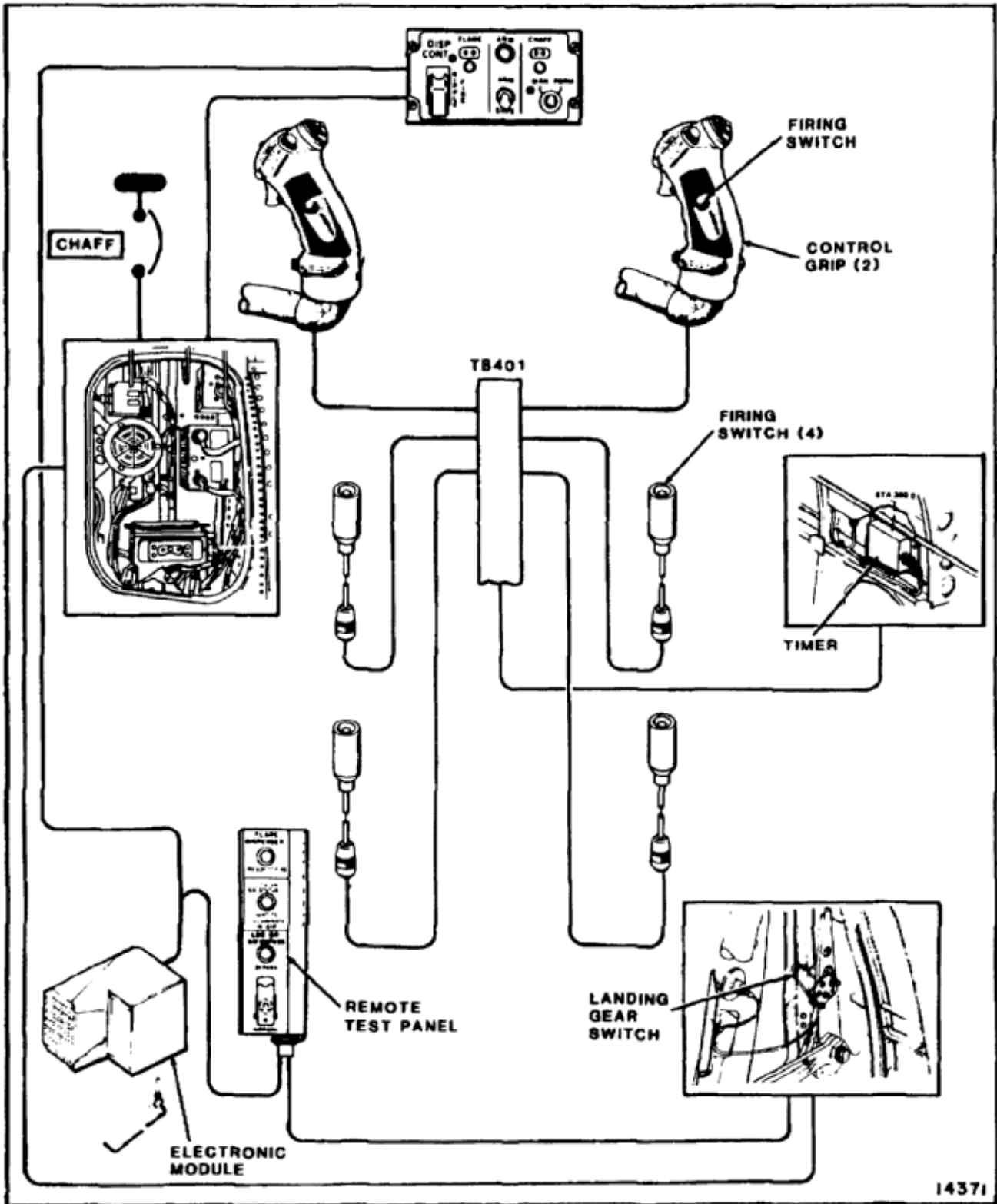

14371

END OF TASK

**SECTION VI**  
**FLARE DISPENSER SYSTEM**

INITIAL SETUP

**Applicable Configurations:**

All

**Tools:**

Electrical Repairer's Tool Kit, NSN 5180-00-323-4915  
Workstand

**Materials:**

None

**Personnel Required:**

Aircraft Electrician

**Equipment Condition:**

Battery Disconnected (Task 1-39)  
Electrical Power Off  
Hydraulic Power Off  
Cargo Ramp Open and Level (TM 55-1520-240-T)  
Safety Pin Installed (TM 55-1520-240-10)  
Acoustic Blanket at Right Side Sta 555 Removed  
(Task 2-208)

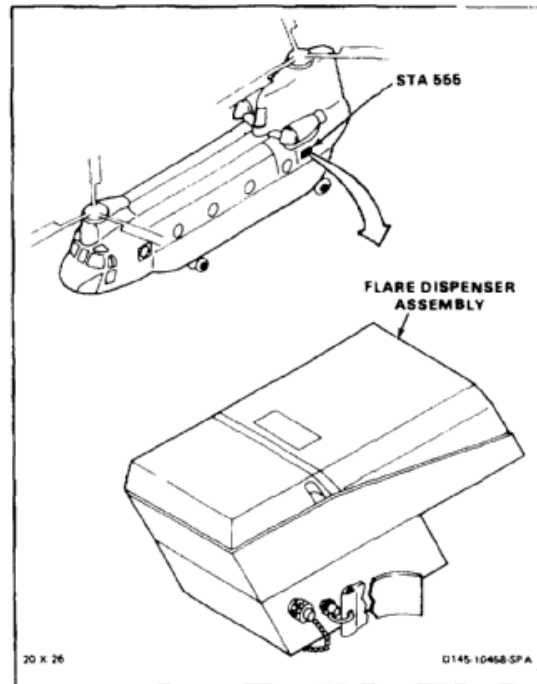

1. From inside helicopter, disconnect electrical plug (1) from receptacle (2).
2. Remove two screws (3) from stowed cover (4). Remove cover.

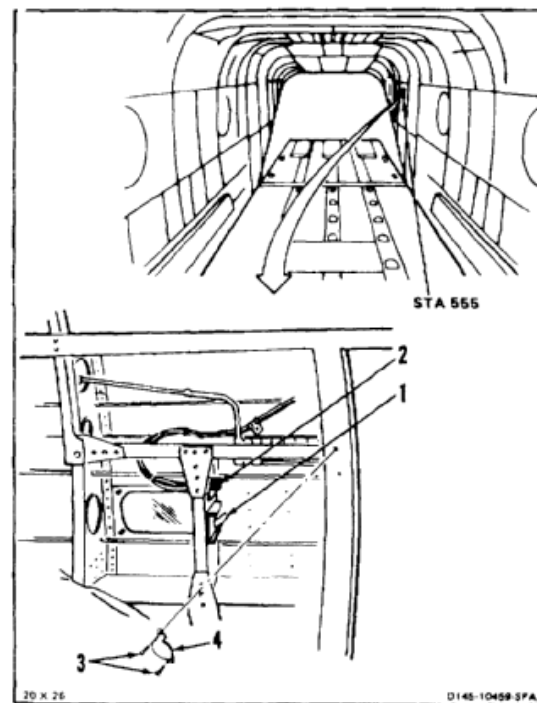

**16-49 REMOVE FLARE DISPENSER ASSEMBLY (Continued)**

16-49

3. From outside helicopter, remove four screws (5) from dispenser (6).
4. Remove dispenser (6).
5. Install two screws (3) and cover (4) on seal (7).

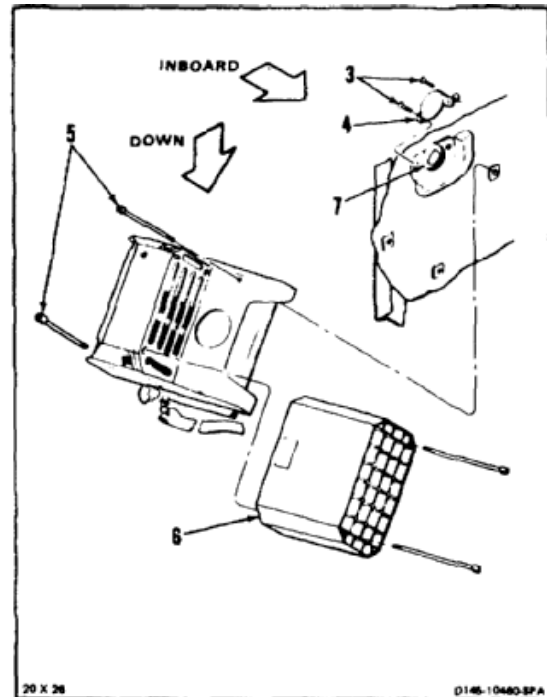
**FOLLOW-ON MAINTENANCE:**

None

END OF TASK

INITIAL SETUP

**Applicable Configurations:**

All

**Tools:**

Electrical Repairer's Tool Kit, NSN 5180-00-323-4915  
Torque Wrench, 5 to 50 Inch-Pounds

**Materials:**

None

**Personnel Required:**

Aircraft Electrician  
Inspector

**References:**

TM 55-1520-240-23P

**General Safety Instructions:**

**WARNING**

Make sure battery is disconnected, electrical power off, arm safe switch is set to safe, ripple fire switch is set to down (guarded), and remote test switch is set to normal. Otherwise, damage, personal injury, or death can occur.

1. From outside helicopter, remove two screws (1) from cover (2). Remove cover.

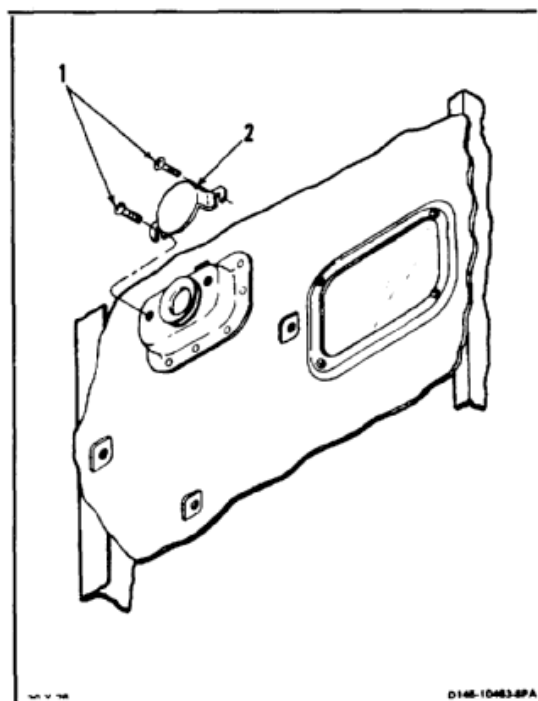
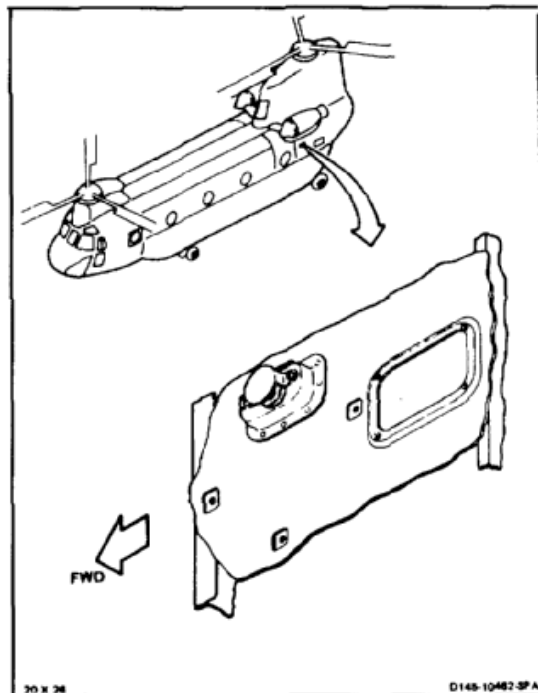



2. Feed electrical plug (3) through seal (4).
3. Position dispenser (5) over seal (4). Install four screws (6).
4. Torque four screws (6) to **40 inch-pounds**.

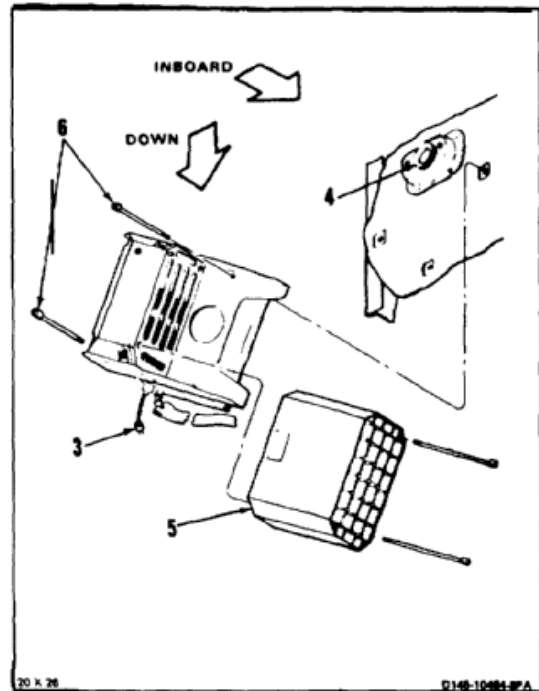

5. From inside helicopter, stow cover (2) by positioning on structure (7). Install two screws (1).
6. Connect electrical plug (3) to receptacle (8).

**INSPECT**

**FOLLOW-ON MAINTENANCE:**

Perform operational check (TM 55-1520-240-T).  
 Close cargo ramp (TM 55-1520-240-T).  
 Install acoustic blanket at right side, sta 555 (Task 2-210).

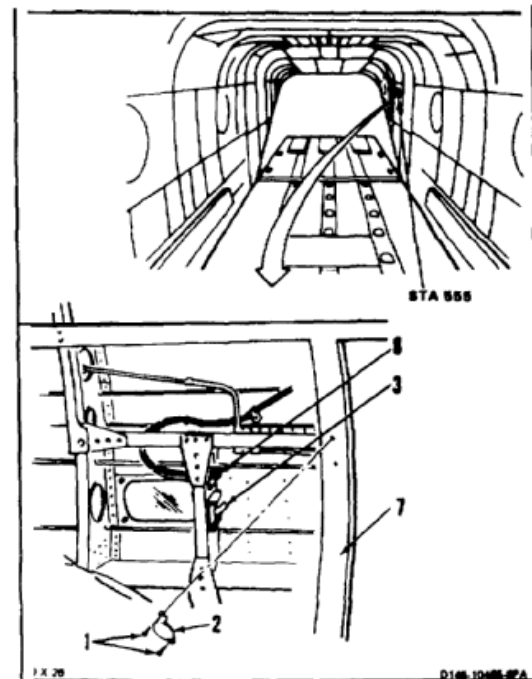

END OF TASK

INITIAL SETUP

**Applicable Configurations:**

All

**Tools:**

Electrical Repairer's Tool Kit, NSN 5180-00-323-4915

**Materials:**

None

**Personnel Required:**

Aircraft Electrician

**Equipment Condition:**

- Battery Disconnected (Task 1-39)
- Electrical Power Off
- Cargo Ramp Open and Level (TM 55-1520-240-T)

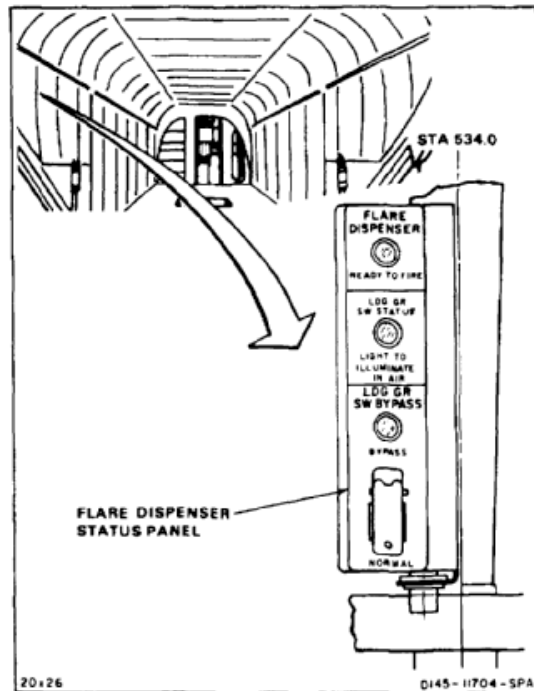

1. Cut lockwire and disconnect plug (1).
2. Remove two screws (2), eight washers (3), and two nuts (4).
3. Remove panel (5).

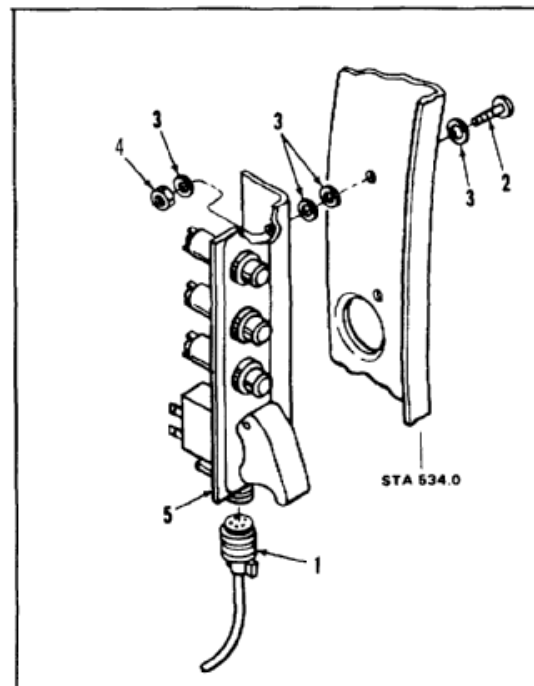

**FOLLOW-ON MAINTENANCE:**

None

END OF TASK

**16-52 DISASSEMBLE FLARE DISPENSER STATUS PANEL**

16-52

## INITIAL SETUP

**Applicable Configurations:**

All

**Tools:**

Electrical Repairer's Tool Kit, NSN 5180-00-323-4915  
Soldering Iron

**Materials:**

Paper Tags (264)

**Personnel Required:**

Aircraft Electrician

**Equipment Condition:**

Off Helicopter Task

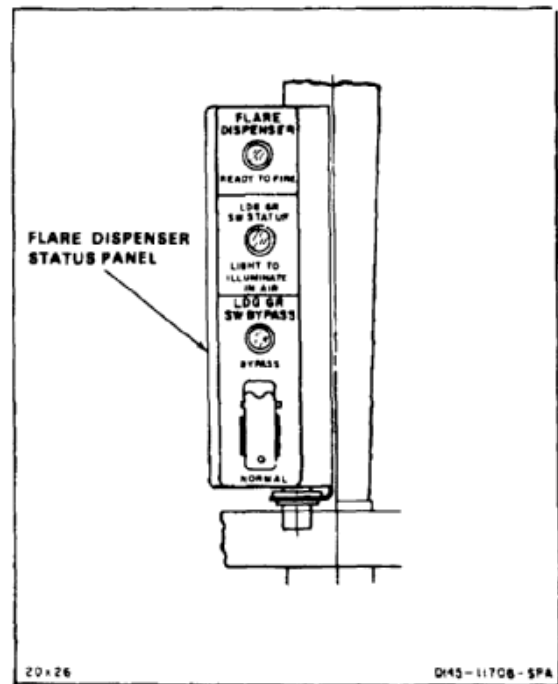

1. Remove lens (1) and lamp (2) from three lights (3).
2. Tag and unsolder 12 wires (4) from three lights (3).
3. Remove three nuts (5) and three lights (3) from bracket (6).
4. Tag five wires (7). Remove screws (8) and washers (9) to disconnect wires from switch (10).
5. Raise switch guard (11) and remove nut (12) and washer (13).
6. Remove switch (10).

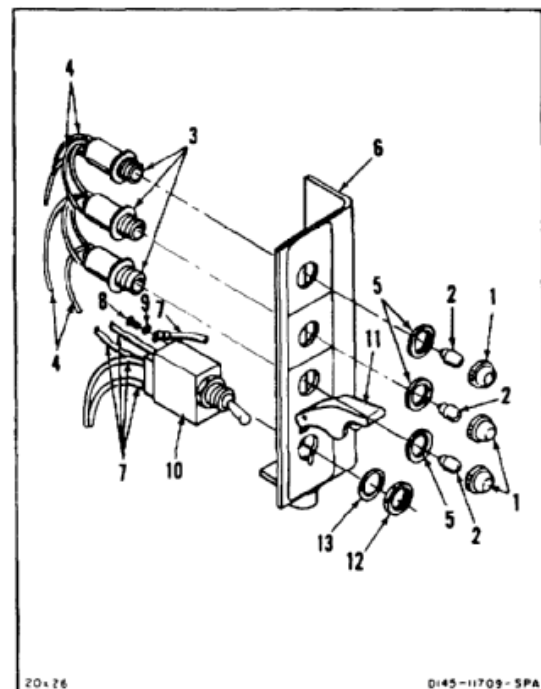
**FOLLOW-ON MAINTENANCE:**

None

END OF TASK

INITIAL SETUP

**Applicable Configurations:**

All

**Tools:**

Electrical Repairer's Tool Kit, NSN 5180-00-323-4915  
Soldering Iron

**Materials:**

Solder (E360)  
Electrical Insulation Tubing (E431)

**Personnel Required:**

Aircraft Electrician  
Inspector

**References:**

TM 55-1520-240-23P

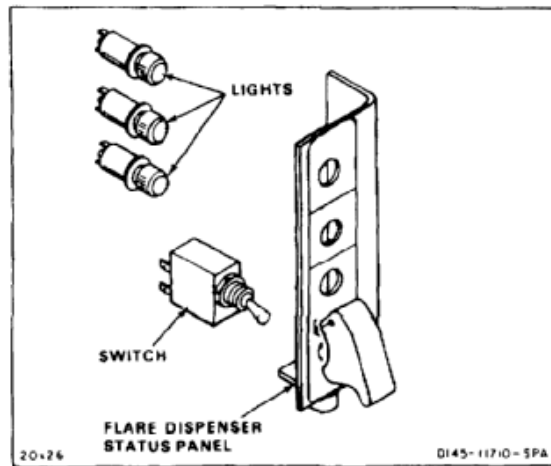

1. Position switch (1) in bracket (2). Raise switch guard (3) and install washer (4) and nuts (6).
2. Remove tags from five wires (6). Connect wires to switch (1). Use washers (7) and screws (8).
3. Position three lights (9) in bracket (2). Install three nuts (10) on three lights.
4. Remove tags from 12 wires (11). Install electrical insulation tubing (E431) (12) on wires. Solder wires to three lights (9). Slide tubing down over solder joints.
5. Install three lamps (13) in lights (9).
6. Install yellow lens (14) on top lamp (13). Install green lens (15) on center lamp (13). Install red lens (16) on bottom lamp (13).

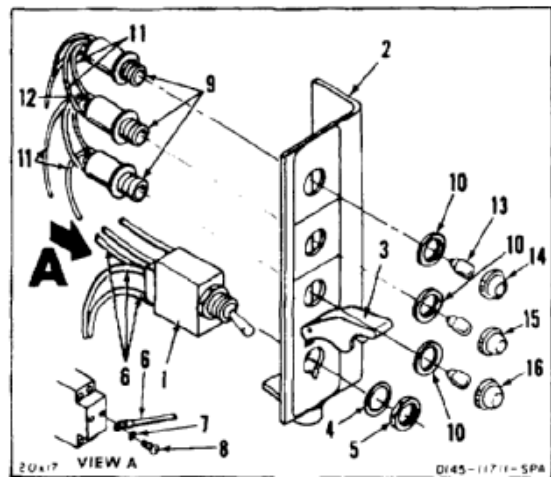

**INSPECT**

**FOLLOW-ON MAINTENANCE:**

None

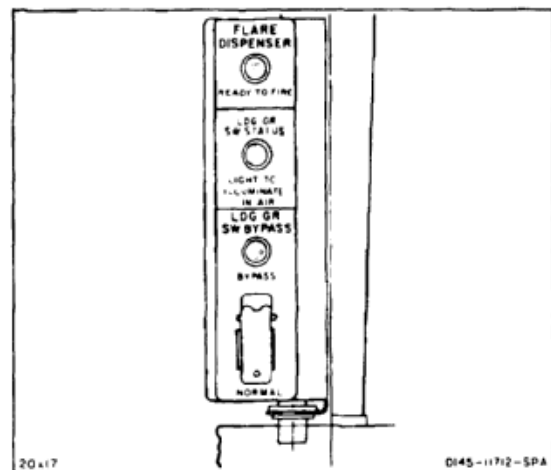

END OF TASK

## INITIAL SETUP

**Applicable Configurations:**

All

**Tools:**

Electrical Repairer's Tool Kit, NSN 5180-00-323-4915

**Materials:**

Lockwire (229)

**Personnel Required:**Aircraft Electrician  
Inspector**References:**

TM 55-1520-240-23P

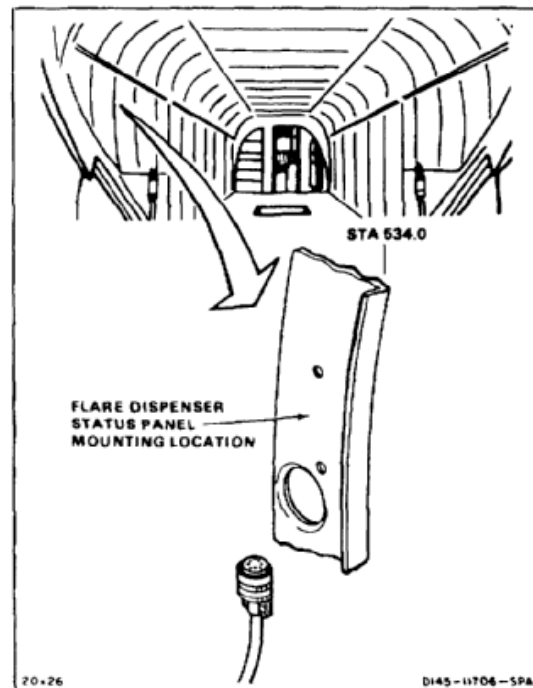

1. Position panel (1) on former (2).
2. Install two screws (3), eight washers (4), and two nuts (5).
3. Connect plug (6) to receptacle (7). Lockwire plug.

**INSPECT****FOLLOW-ON MAINTENANCE:**

Perform operational check of flare dispenser system (TM 55-1520-240-T).  
Close cargo ramp (TM 55-1520-240-T).

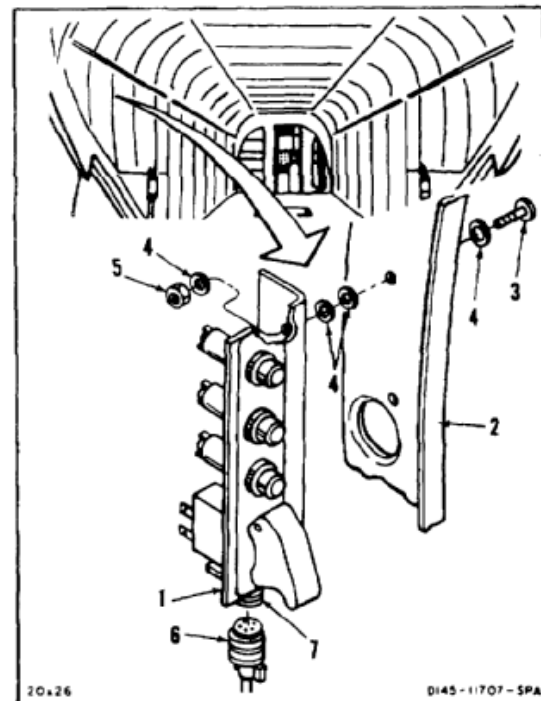

END OF TASK

INITIAL SETUP

**Applicable Configurations:**

All

**Tools:**

Electrical Repairer's Tool Kit, NSN 5180-00-323-4915

**Materials:**

Tag (E264)

**Personnel Required:**

Aircraft Electrician

**Equipment Condition:**

Battery Disconnected (Task 1-39)  
 Electrical Power Off  
 Hydraulic Power Off

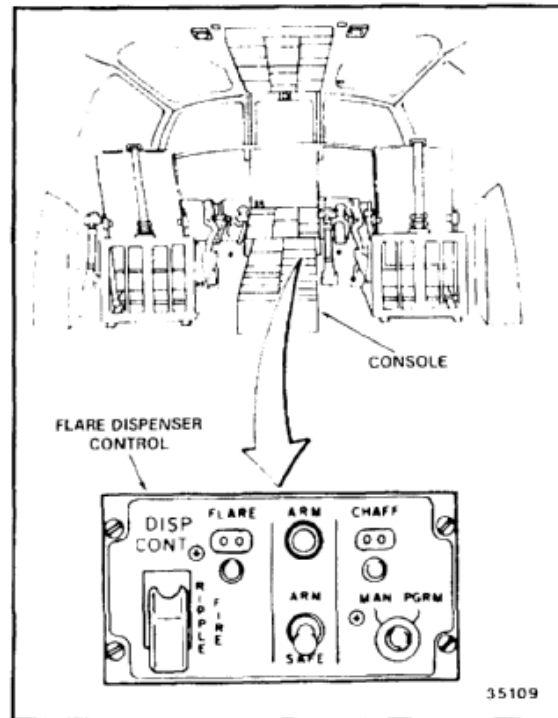

1. Loosen four fasteners (1) on flare dispenser control panel (2).
2. Lift flare dispenser control panel (2) from console (3).
3. Tag and disconnect electrical connector (4) from flare dispenser control panel (2). Use tag (E264).
4. Remove flare dispenser control panel (2).

**FOLLOW-ON MAINTENANCE:**

None

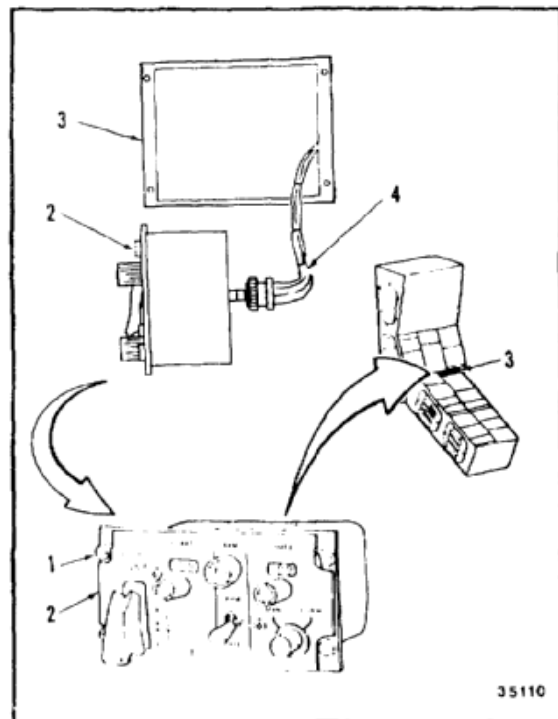

END OF TASK

**16-54.2 INSTALL FLARE DISPENSER CONTROL PANEL**

16-54.2

**INITIAL SETUP****Applicable Configurations:**

All

**Tools:**

Electrical Repairer's Tool Kit, NSN 5180-00-323-4915

**Materials:**

None

**Personnel Required:**Aircraft Electrician  
Inspector**References:**

TM 55-1520-240-23P

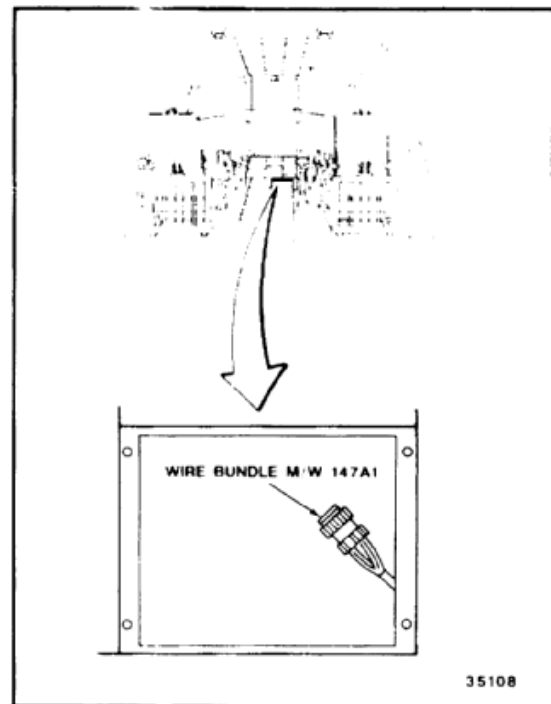

Insure that wire bundle marked as "mates with M/W 147A1" is connected to flare dispenser control connector.

1. Connect electrical connector (1) to receptacle (2) on flare dispenser control panel (3). Remove tag.
2. Position flare dispenser control panel (3) on console (4).
3. Tighten four fasteners (5).

**INSPECT****FOLLOW-ON MAINTENANCE:**

Perform operational check (TM 55-1520-240-T).

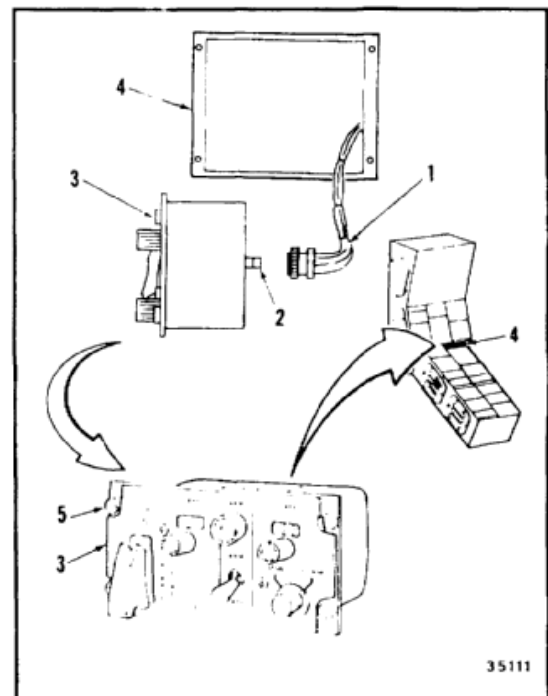

END OF TASK

INITIAL SETUP

**Applicable Configurations:**

All

**Tools:**

Electrical Repairer's Tool Kit, NSN 5180-00-323-4915  
 Multimeter  
 Test Set, NSN 4940-01-048-9677  
 Stopwatch

**Materials:**

None

**Personnel Required:**

Aircraft Electrician  
 Inspector

**References:**

TM 9-1095-206-13  
 TM 11-1520-240-23

**Equipment Condition:**

Battery Disconnected (Task 1-39)  
 Electrical Power Off  
 Hydraulic Power Off  
 Countermeasures Control Indicator Removed (TM 11-1520-240-20)

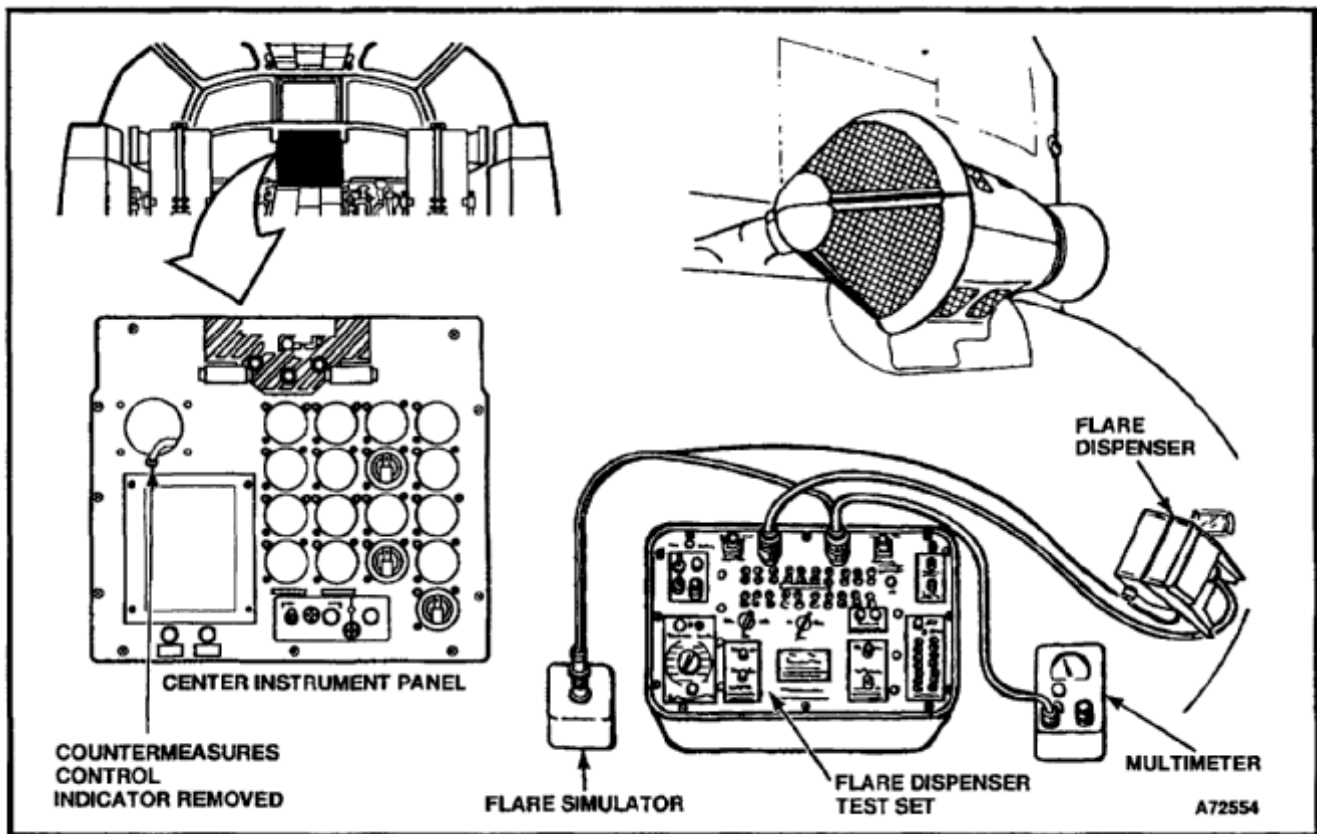



1. Connect multimeter (1) to pins A (2) and B (3). Multimeter, set to RX1000, shall indicate more than **3000 ohms**.
2. Disconnect multimeter (1) from pin B (3) and connect to ground. Multimeter shall indicate more than **3000 ohms**.
3. Disconnect and remove multimeter (1).

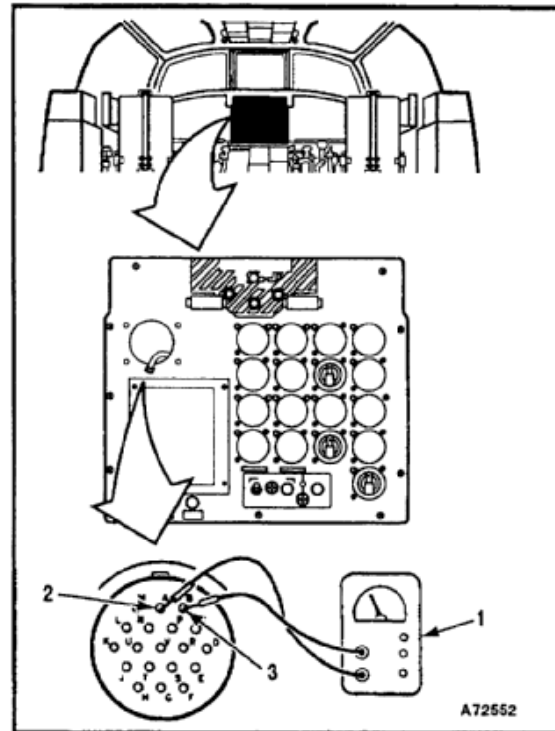

4. Install countermeasures control indicator (4) (TM 11-1520-240-23).
5. Apply electrical power.

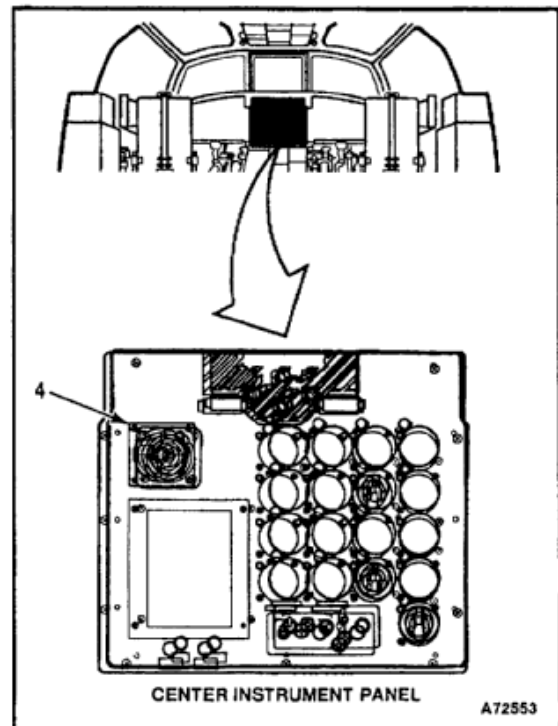

6. Connect test set (5) to flare dispenser (6) (TM 9-1095-206-13).
7. Perform steps 1 thru 13 of flare dispenser electrical system test on aircraft with one dispenser used for flare (TM 9-1095-206-13).

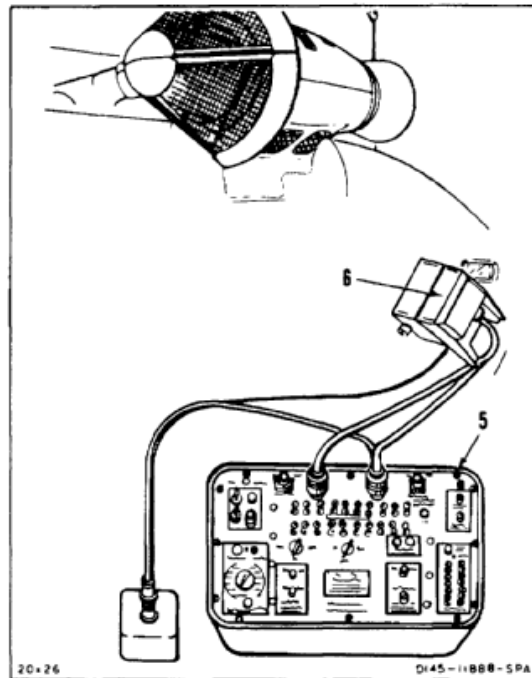

8. Close CHAFF (7) and CONSOLE (8) circuit breakers on No. 1 power distribution panel (9).
9. Perform steps 14 thru 23 of flare dispenser electrical system TEST (TM 9-1095-206-13).

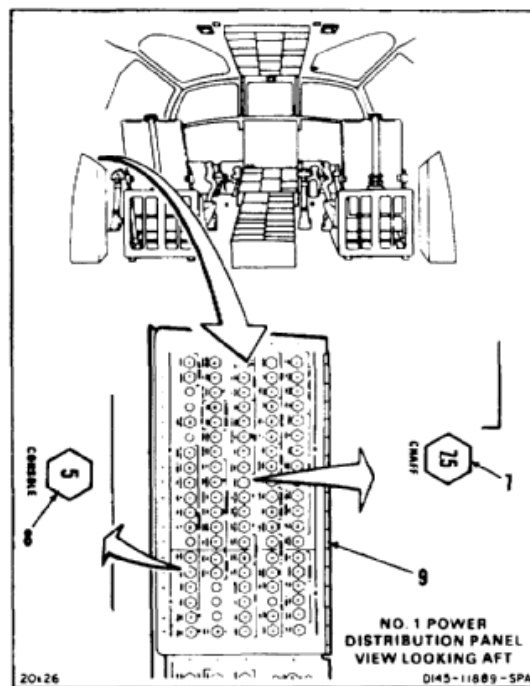

**16-55 TEST FLARE DISPENSER SYSTEM (Continued)****16-55**

10. Press switch (10) on pilot's control stick grip (11) for **10 seconds**. Flare simulator (12) will flash every **2.5 seconds**.
11. Perform steps 24 thru 35 of FLARE DISPENSER ELECTRICAL SYSTEM TEST (TM 9-1095-206-13).

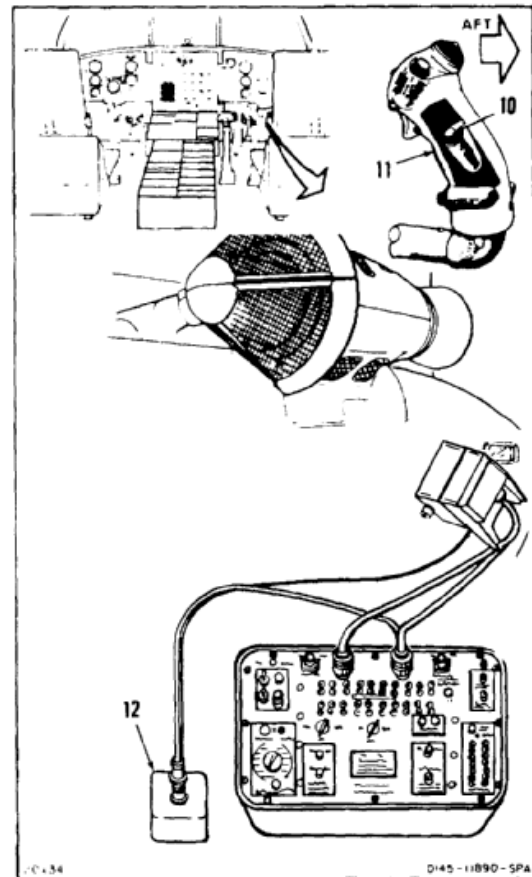

12. Raise switch guard (13) and set switch (14) on STATUS panel (15) to NORMAL.
13. Press switch (10) on pilot's control stick grip (11). Counter (16) on DISP CONTROL panel (17) shall read 30.

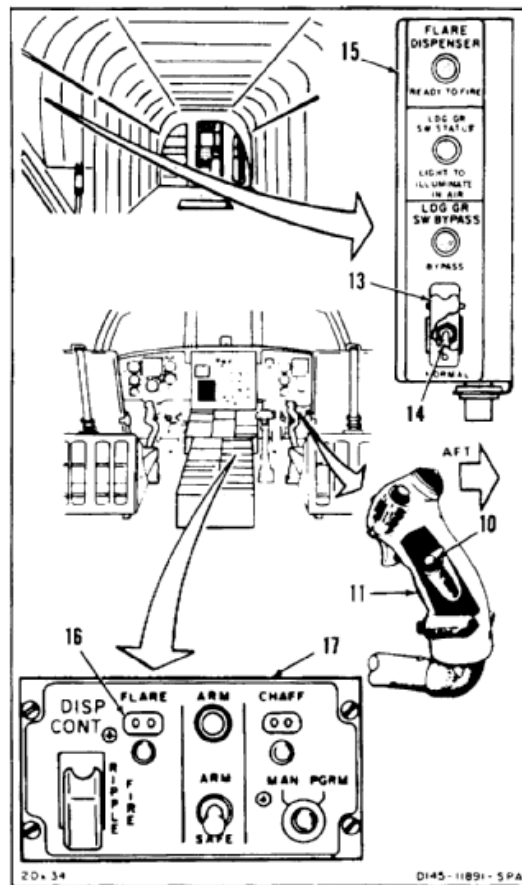

14. Check test set (5). Firing order indicators (18) shall be red.

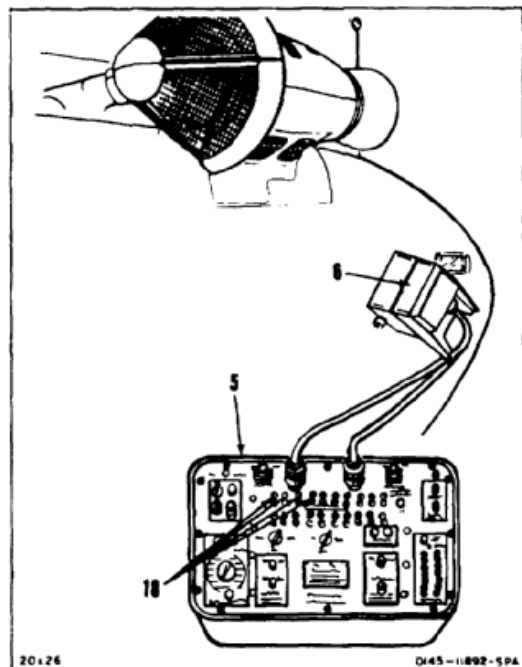

15. Set ARM-SAFE switch (19) on DISP CONT panel (17) to SAFE. ARM light (20) shall go out.
16. Repeat steps 13 and 14.
17. Open CHAFF (7) and CONSOLE (8) circuit breakers on No. 1 power distribution panel (9).
18. Perform steps 36 and 39 thru 44 of Flare Dispenser Electrical System TEST (TM 9-1095-206-13).

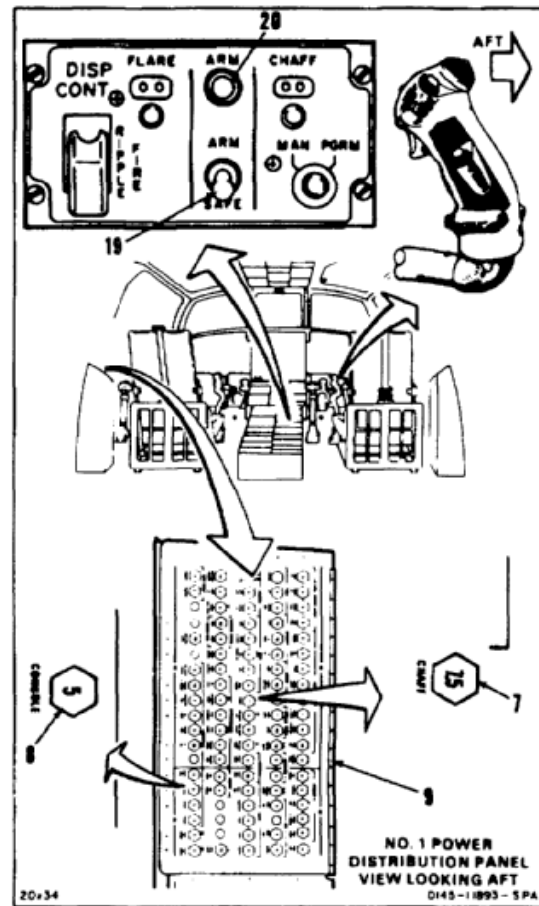

**FOLLOW-ON MAINTENANCE:**

Remove electrical power.

END OF TASK

INITIAL SETUP

**Applicable Configurations:**

All

**Tools:**

Electrical Repairer's Tool Kit, NSN 5180-00-323-4915

**Materials:**

None

**Personnel Required:**

Aircraft Electrician

**Equipment Condition:**

- Battery Removed (Task 1-39)
- Electrical Power Off
- Remove Blankets (Task 2-208)

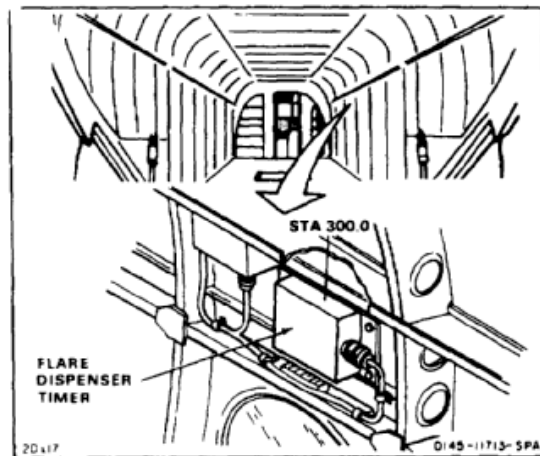

1. Disconnect plug (1) from timer (2).
2. Remove four screws (3), washers (4), and timer (2).

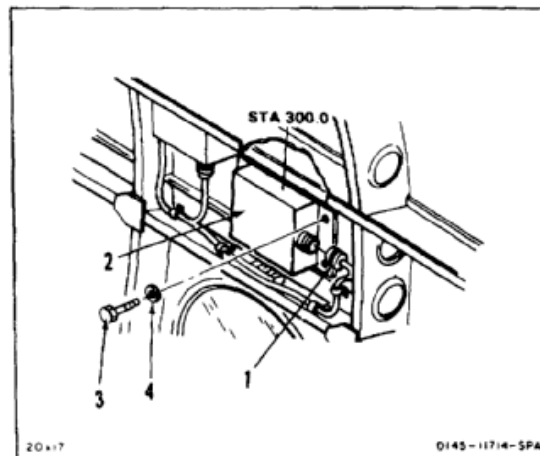

3. Remove six screws (5). Remove base (6) from timer (2).

**FOLLOW-ON MAINTENANCE:**

None

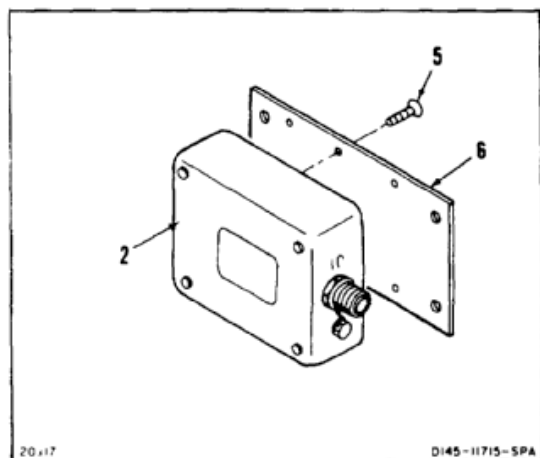

END OF TASK

## INITIAL SETUP

**Applicable Configurations:**

All

**Tools:**

Electrical Repairer's Tool Kit, NSN 5180-00-323-4915

**Materials:**

None

**Personnel Required:**Aircraft Electrician  
Inspector**References:**

TM 55-1520-240-23P

1. Position timer (1) on base (2). Install six screws (3).

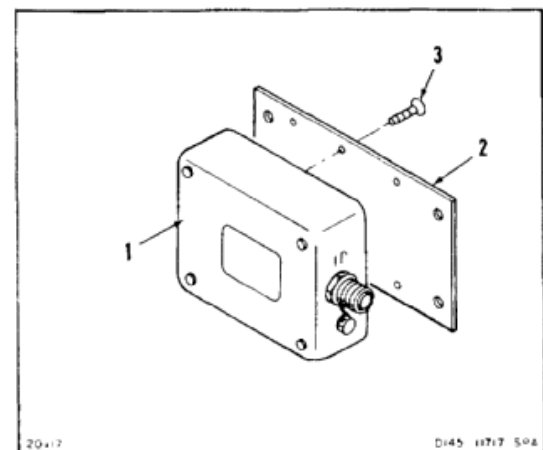
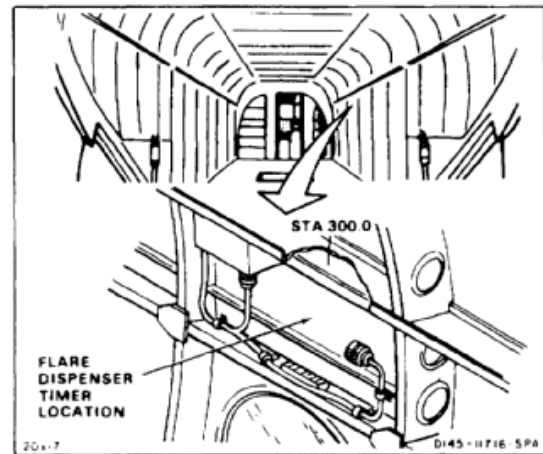

2. Position timer (1) on mounting bracket (4). Install four screws (5) and washers (6).
3. Connect plug (7) to timer (1).

**FOLLOW-ON MAINTENANCE:**

Perform operational check of flare dispenser system (TM 55-1520-240-T).  
Install blankets (Task 2-210).

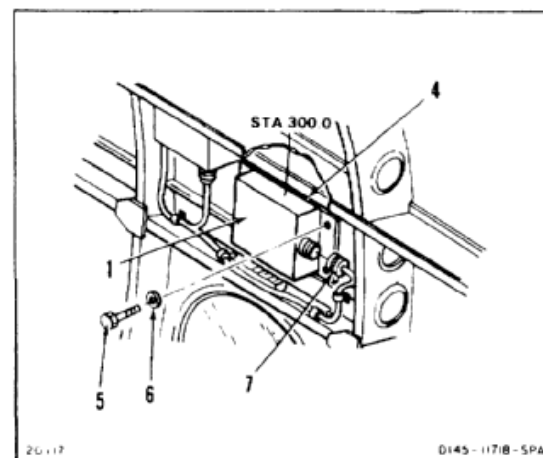

END OF TASK

INITIAL SETUP

**Applicable Configurations:**

All

**Tools:**

Electrical Repairer's Tool Kit, NSN 5180-00-323-4915

**Materials:**

Tape (E385)  
Paper Tags (E264)

**Personnel Required:**

Aircraft Electrician

**Equipment Condition:**

Battery Removed (Task 9-25)  
Electrical Power Off

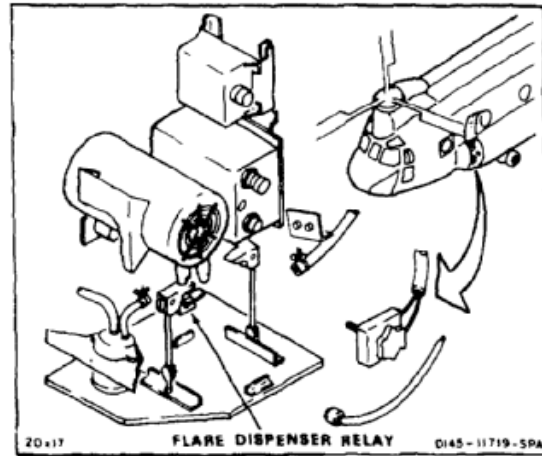

1. Remove six screws (1) and washers (2).
2. Tag and disconnect seven wires (3) from relay (4). Tape wire ends.

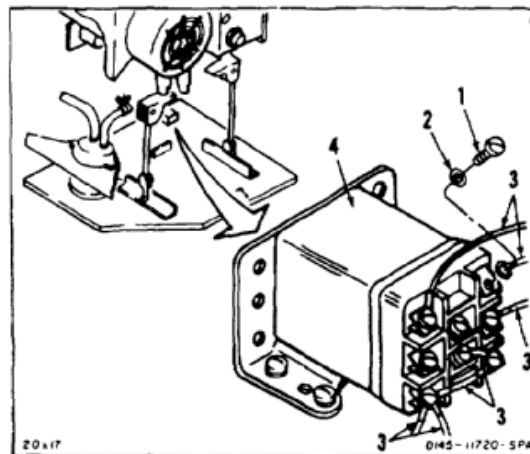

3. Remove four screws (5) and washers (6).
4. Remove relay (4).

**FOLLOW-ON MAINTENANCE:**

None

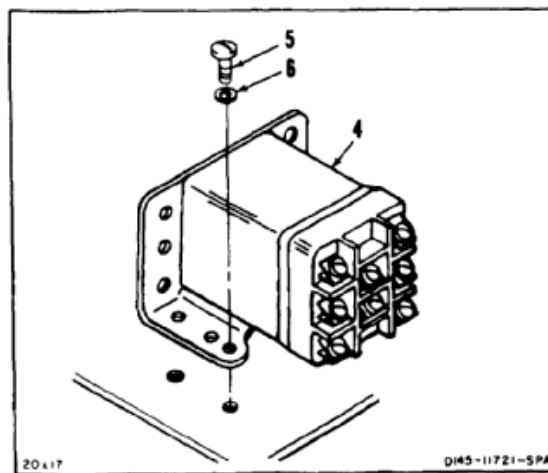

END OF TASK



## INITIAL SETUP

**Applicable Configurations:**

All

**Tools:**

Electrical Repairer's Tool Kit, NSN 5180-00-323-4915

**Materials:**

None

**Personnel Required:**Aircraft Electrician  
Inspector**References:**

TM 55-1520-240-23P

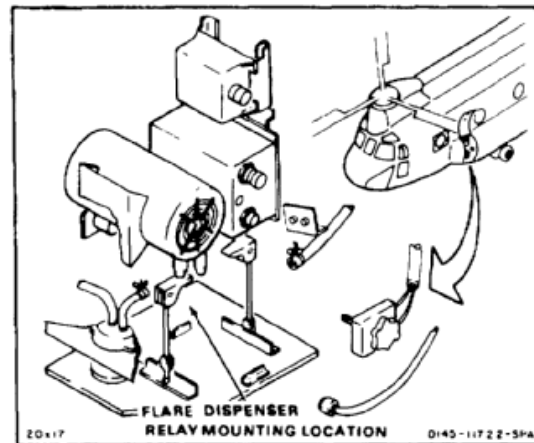

1. Position relay (1) on shelf (2). Install four screws (3) and washers (4).

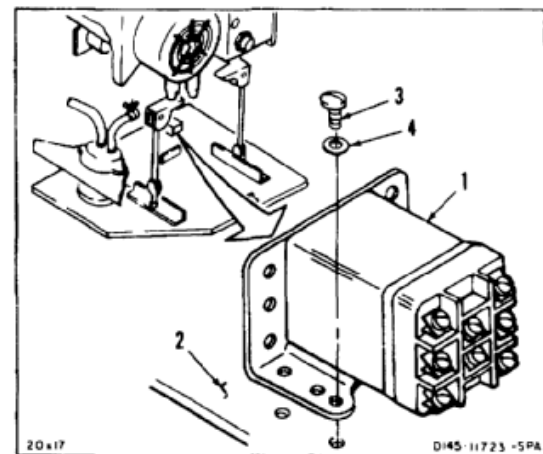

2. Remove tape and tags from seven wires (5).
3. Connect seven wires (5) with six screws (6) and washers (7).

**INSPECT****FOLLOW-ON MAINTENANCE:**

Install battery (Task 9-27).  
Perform operational check of flare dispenser system  
(TM 55-1520-240-T).

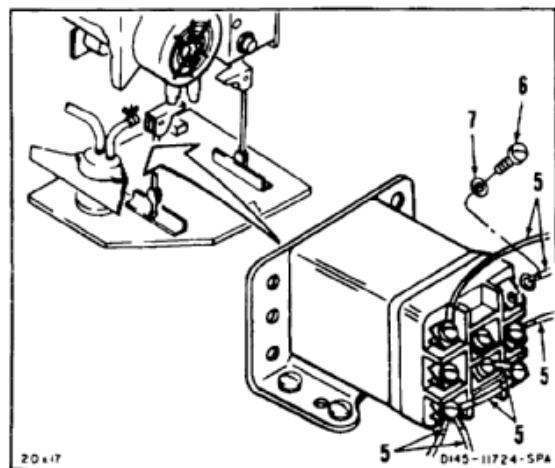

END OF TASK



**SECTION VI.1**  
**AN/ALE-47 COUNTERMEASURES DISPENSER SYSTEM (CMDS)**  
**DESCRIPTION AND THEORY OF OPERATION**

**DESCRIPTION**

The AN/ALE-47 Countermeasures Dispenser System (CMDS) is comprised of the following components: a Digital Control Display Unit (DCDU), a programmer, a junction box, two sequencers, and four dispenser assemblies each containing a payload module (magazine). The system also contains a safety switch, a Mission Load Verifier (MLV) interface port, flare dispense buttons on the pilot's and copilot's cyclic grip, four crew dispense buttons, and a landing gear bypass switch status panel.

The DCDU (located in the center console), provides cockpit interface for manual inputs, such as mode selection, payload inputs, manual dispense program selection, emergency jettison of expendables, and other operational commands. It also displays system status built-in test, expendable inventories, selected functions, and other system feedback data.

The AN/ALE-47 programmer, located at STA 355.00 in the left side of the cabin, is the central processing unit for the CMDS and provides the interface between the DCDU and the four flare dispensers via two sequencers. The programmer receives input data from the AN/ALQ-156 missile detection system, processes it to determine the appropriate dispense response, and sends fire commands to the sequencers when the CMDS is in Auto or Semi Auto mode of operation.

The software program within the programmer that manages all communications, operations, and calculations is called the Operational Flight Program (OFP). The programmer also contains the Mission Data File (MDF) which is user-programmable and contains data elements that enable the CMDS to be configured to specific payload types, dispense sequence, and dispense quantities. The OFP and MDF are loaded into the programmer using the Mission Load Verifier (MLV) via the MLV interface port located in the cabin at STA 359.00 overhead.

The junction box provides a centralized location for easy access to CMDS electrical connections between system components while reducing electro magnetic interference impact in the cabin.

There are two AN/ALE-47 sequencers installed in the aft cabin at STA 547.00 BL40R and STA 543.00 BL40R. The sequencers receive payload type and fire commands from the programmer over the Sequencer Data Link (SDL). The sequencers select the dispenser with the appropriate payload and send high power impulses to the dispenser and magazine to dispense

the programmed expendable. The sequencers also detect magazine type, monitor the remaining inventories in the magazines, and detect payload misfires. This information is sent to the programmer via the SDL. Each sequencer also performs internal BIT. Sequencer No. 1 controls the two dispensers (1 and 3) on the LH side of the aircraft, and sequencer No. 2 controls the two dispensers (2 and 4) on the RH side of the aircraft.

A safety switch located at STA 518.00 BL50L is installed in the CMDS to provide a safeguard against inadvertent dispensing of the expendables. When the safety pin is installed in the safety switch, squib power (**28 vdc**) from the programmer to the sequencers is interrupted, inhibiting dispensing of expendables. The safety switch provides ground to the AN/ALE-47 squib power relay (located in the AN/ALE-47 junction box at STA 410.00 BL22.5L) when safety pin is removed allowing squib power to the sequencers.

Four flare dispenser assemblies are mounted in pairs on the LH and RH sides of the aft fuselage. Each dispenser assembly consists of housing and a breech. The breech provides interface for the payload module and routes firing and polling pulses from the sequencers to the payload squibs.

The payload module assemblies are mounted on the dispenser assemblies. Each payload module assembly consists of a payload module and breech plate. The payload modules can hold up to 30 expendable cartridges which are loaded and installed in the dispenser assemblies prior to the mission.

Manual dispensing of expendables is done by pressing the FLARE DISP buttons on the pilot's and copilot's cyclic grip or by using one of the four crew dispense buttons located at STA 200.00 and 400.00 L and R in the cabin. Setting the DCDU MODE switch to MAN and the MANUAL switch to positions 1, 2, 3, or 4, enables the pilot or copilot to manually dispense expendables. Manual dispensing by crewmembers is accomplished by pressing one of the four crew dispense buttons with the DCDU mode switch in MAN.

The landing gear bypass switch status panel enables testing of the CMDS when the aircraft is in a weight-on-wheels (WOW) condition by allowing the proximity switch on the aft landing gear to be bypassed. During normal operations, the NORMAL/BYPASS switch on landing gear bypass switch status panel is in the NORMAL position. During testing and maintenance, the switch is placed in the BYPASS position, which bypasses the proximity switch to enable the CMDS.

The AN/ALE-47 Countermeasures Dispenser System Payload Modules are capable of being loaded with 3 types of expendables: XM211, XM212, and M206. They use either the M796 or BBU-35/B cartridge.

1. Flare, Aircraft: Countermeasure, XM211 is an infrared decoy cartridge to be used with any aircraft dispenser system capable of firing the M206 flare.

**WARNING**

The XM211 flare is not a substitute for the M206.

- a. **Type Classification.** N/A
- b. **Use.** This flare is dispensed from aircraft to decoy infrared seeking missile threats away from the aircraft.
- c. **Description.** The XM211 flare consists of an aluminum case which contains a receptacle (squib cup) for an impulse cartridge, a piston, and a payload of stacked advanced material foil elements, which are pyrophoric (reacts with air). The flare is approximately 8" long and has a cross section of 1" X 1", and weighs approximately 2/3 pound. Nomenclature and part number are printed on the flare.

**NOTE**

Later configurations of the flare may contain a decal located at the squib end.

- d. **Functioning.** The impulse cartridge receives a firing signal from the aircraft's on-board deployment system. Once the firing signal is received, expanding hot gases from the impulse cartridge eject the highly air-reactive payload from the cartridge case into the air stream.

**e. Tabulated Data:**

NSN .....	1370-01-460-1684
Drawing Number .....	12988788
Weight .....	Approx. 0.66 lb
Length .....	8.10 in
Width .....	0.97 in
Method of Actuation ..	Impulse ctg. M796 or BBU-35/B
Body Material .....	Aluminum
Color .....	Anodized Aluminum

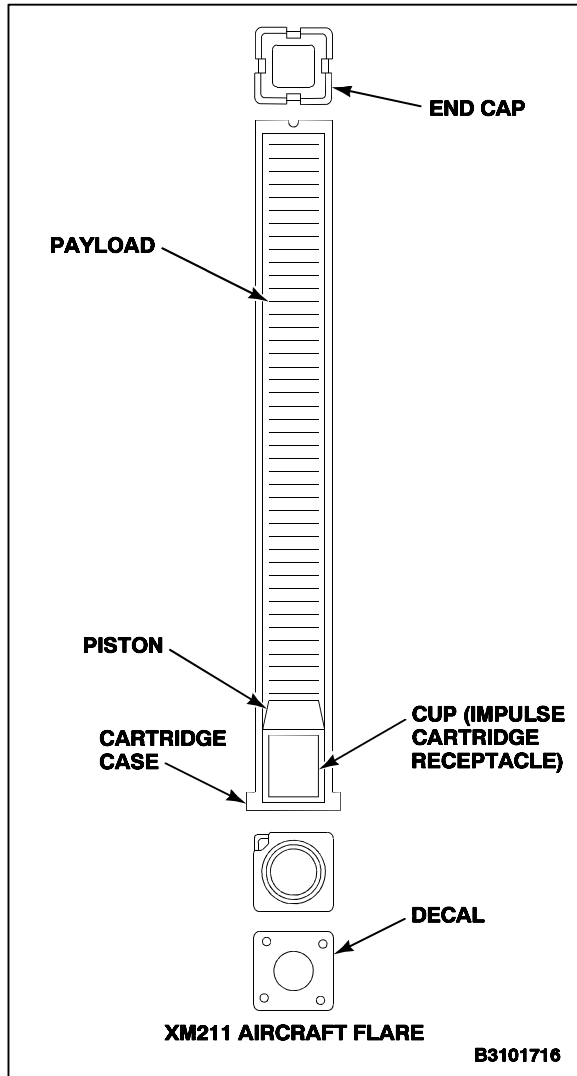

**Pyrotechnic Charge:**

Type .....	Foil, Pyrophoric
Weight .....	240 g
Packing .....	72 per wood box (2 PA19 metal cans of 36 ea)

**Packing Box:**

Weight .....	92 lb
Dimensions .....	14-1/2 in X 13 in X 11 in
Cube .....	1.3 cu ft

f. **Shipping and Storage Data:**

Quantity-Distance  
 Class ..... 4.2  
 Storage Compatibility  
 Group ..... G  
 DOT Markings ..... PYROPHORIC  
 METAL (Activated Iron)  
 DODAC ..... 1370-LA14

g. **References:** TM 9-1095-206-12&P  
 TB 9-1370-211-12

2. Flare, Aircraft: Countermeasure, XM212 is an infrared decoy cartridge to be used with any aircraft dispenser system capable of firing the M206 flare.

**WARNING**

The XM212 flare is not a substitute for the M206.

- a. **Type Classification.** N/A
- b. **Use.** This flare is dispensed from aircraft to decoy infrared seeking missile threats away from the aircraft.
- c. **Description.** The XM212 flare consists of an aluminum case which contains a piston, a Safe and Initiation (S&I) device, and a flare pellet grain assembly. The flare is approximately 8" long and has a cross section of 1" X 1", and weighs approximately 1/2 pound. Nomenclature and part number are printed on the flare.

**NOTE**

Later configurations of the flare may contain a decal located at the squib end.

- d. **Functioning.** The impulse cartridge receives a firing signal from the aircraft's on-board deployment system. Once the firing signal is received, expanding hot gases from the impulse cartridge simultaneously ignite the S&I device and expel the flare out of the case and into the slipstream. When the flare exits the case, the S&I device ignites the flare pellet.

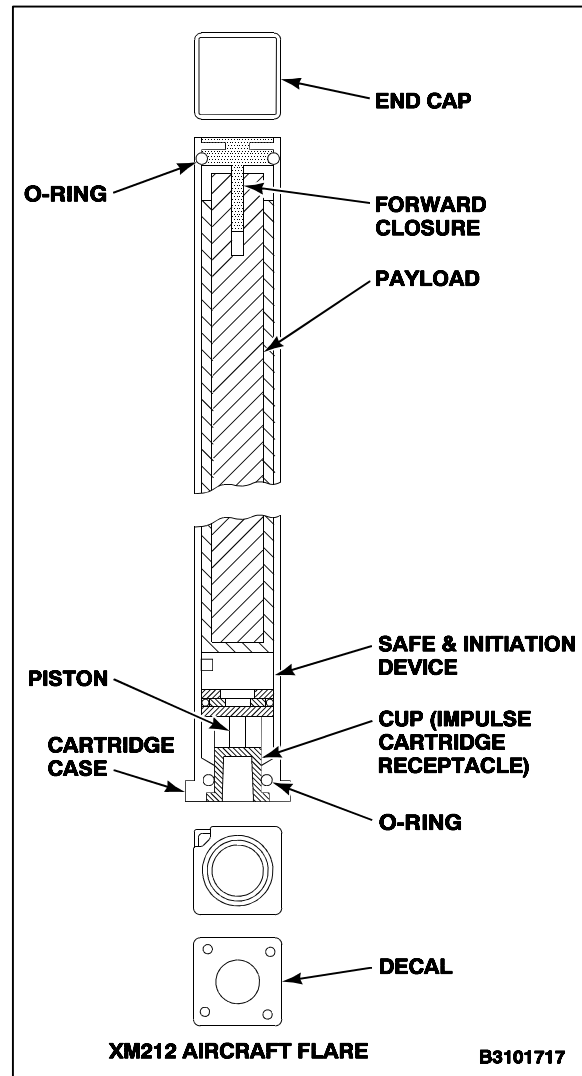

e. **Tabulated Data:**

NSN .....	1370-01-460-1687
Weight .....	Approx. 0.5 lb
Length .....	8.10 in
Width .....	0.97 in
Method of Actuation ..	Impulse ctg. M796 or BBU-35/B
Body Material .....	Aluminum
Color .....	Anodized Aluminum
Pyrotechnic Charge:	
Type .....	Classified (pellet form)
Weight .....	110 g
Packing .....	100 per box (2 PA19 metal cans of 50 ea)
Packing Box:	
Weight .....	75 lb
Dimensions .....	14-1/2 in X 13 in X 11 in
Cube .....	1.3 cu ft

f. **Shipping and Storage Data:**

Quantity-Distance	
Class .....	1.3
Storage Compatibility	
Group .....	G
DOT Markings .....	SPECIAL FIREWORKS HANDLE CAREFULLY KEEP FIRE AWAY
DODAC .....	1370-LA15

g. **References:** TM 9-1095-206-12&P  
TB 9-1370-212-12

3. Flare, Aircraft: Countermeasure, M206 is an infrared decoy to be used with aircraft dispenser systems and shall not be substituted with the XM211 or XM212 flares.

a. **Type Classification.** N/A

b. **Use.** This flare is dispensed from aircraft to decoy infrared seeking missile threats away from the aircraft.

c. **Description.** The M206 flare is wrapped with an aluminum filament reinforced tape and inserted into an aluminum case that is closed with a felt spacer and a small plastic end cap.

d. **Functioning.** The top of the case has a pyrotechnic impulse cartridge that is activated electrically to produce hot gases that push a piston, flare material and end cap out of the aircraft into the air stream.

e. **Tabulated Data:**

NSN .....	1370-01-048-2138
Weight .....	6.8 oz
Length .....	8.08 in (20.52 cm)
Width .....	0.99 in (2.51 cm)
Method of Actuation ..	Impulse ctg. M796 or BBU-35/B
Body Material .....	Aluminum
Color .....	Anodized Aluminum
Pyrotechnic Charge:	
Type .....	pellet

f. **Shipping and Storage Data:**

Quantity-Distance	
Class .....	1.3
Storage Compatibility	
Group .....	G
DOT Markings .....	SPECIAL FIREWORKS HANDLE CAREFULLY KEEP FIRE AWAY
DOT Shipping Class ..	B

g. **References:** TM 9-1095-206-12&P

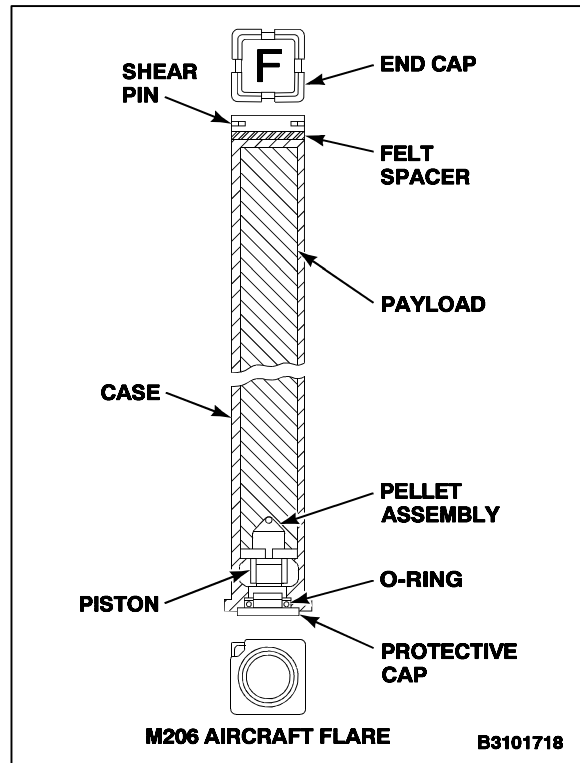

4. Cartridge, Impulse, M796: (MD73) or BBU-35/B is used with the M206, XM211 and XM212.

- a. **Type Classification.** ATC-S LOC-A Refer to Aircraft Subsystem.
- b. **Use.** Ignition source for the M206, XM211 and XM212 flare cartridges.
- c. **Description.** The M796 cartridge consists of an aluminum case, header assembly, igniter charge, booster charge, output charge, closure disc and closure washer. The BBU-35/B is similar but without the closure washer.

d. **Tabulated Data:**

NSN ..... 1377-01-049-6365  
 DODIC ..... MD73  
 Drawing Number ..... 9311660  
 Cage Code/PN ..... (14083) 9311660  
 Item Weight ..... 0.278 lb (0.126 kg)  
 Diameter ..... 0.625 in (1.59 cm)  
 Length ..... 0.50 in (1.40 cm)  
 Method of Actuation . . . Electrical  
 Body Material ..... Aluminum  
 Propellant/Explosive Material:  
   Type ..... HPC 1, M1911  
   Weight ..... 0.0088 lb (61.6 g)  
 Firing Temperature Limits:

Upper ..... +160°F (+71°C)  
 Lower ..... -65°F (-54°C)

e. **Packaging:**

Inner Container:  
 Reference ..... MIL-C-10464  
 Type ..... Type I, hermetically sealed metal container  
 Dimensions ..... TBD  
 Items Per Package .. 60  
 Weight ..... 1.67 lb (0.758 kg)  
 Outer Container:  
 Reference ..... PPP-B-636  
 Type ..... Fiberboard Box  
 Dimensions ..... TBD  
 Weight ..... 60 lb (27.22 kg)

f. **Shipping and Storage Data:**

Quantity-Distance  
 Class ..... 1.4  
 Storage Compatibility  
 Group ..... S  
 DOT Shipping Class . . C  
 DOT Designation ..... ELECTRICAL SQUIB, IGNITERS, HANDLE CAREFULLY KEEP FIRE AWAY  
 UNO Serial Number . . 0454

g. **References:** TM 9-1377-200-20  
 TM 9-1095-206-12&P  
 TB 9-1300-385, APP B

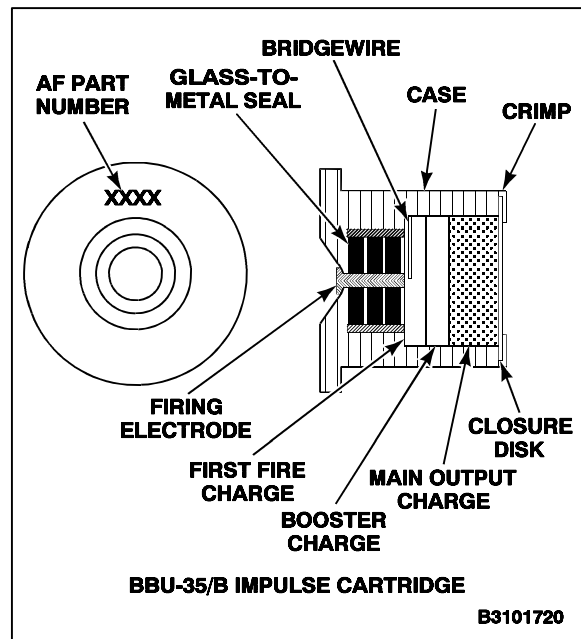
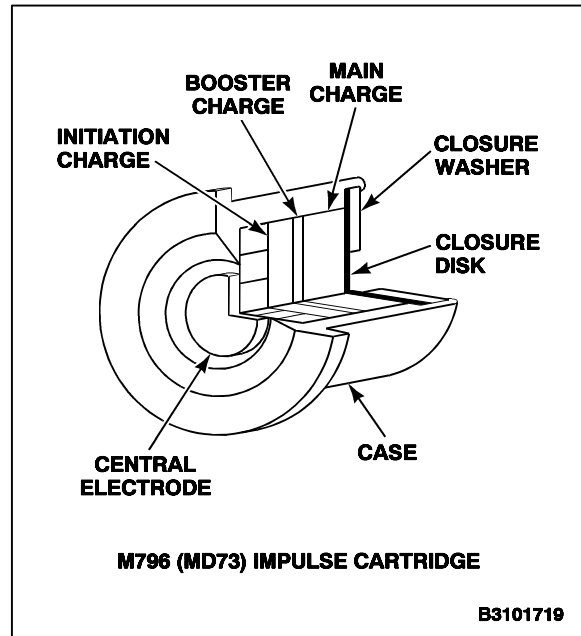



***THEORY OF OPERATION***

The CMDS provides the aircraft with protection from air-to-air and surface-to-air heat-seeking missiles. Modes of operation are manual (five stored programs), semi-automatic (operator/sensor activated), and automatic (operator/sensor activated). The CMDS is integrated with the AN/ALQ-156 Missile Detection System to automatically dispense expendables when detected by the AN/ALQ-156 when in the Auto or Semi Auto mode of operation. The CMDS may be pre-programmed to generate optimum expendable response in a single or multiple threat environment.

Power requirement for the CMDS is **28 vdc, 2 amps** max in STANDBY and **7 amps for 20 milliseconds** during each squib ignition, is taken from the No. 1 DC Bus. The three circuit breakers (CB) for the CMDS are found on the No. 1 EAPS PDP labeled ALE-47, beside the copilot. Power for the DCDU is taken through a **5 amp** CB labeled DCDU. Power required to jettison expendables is taken through two **10 amp** CBs labeled SQUIB PWR NO. 1 SEQ and NO. 2 SEQ.

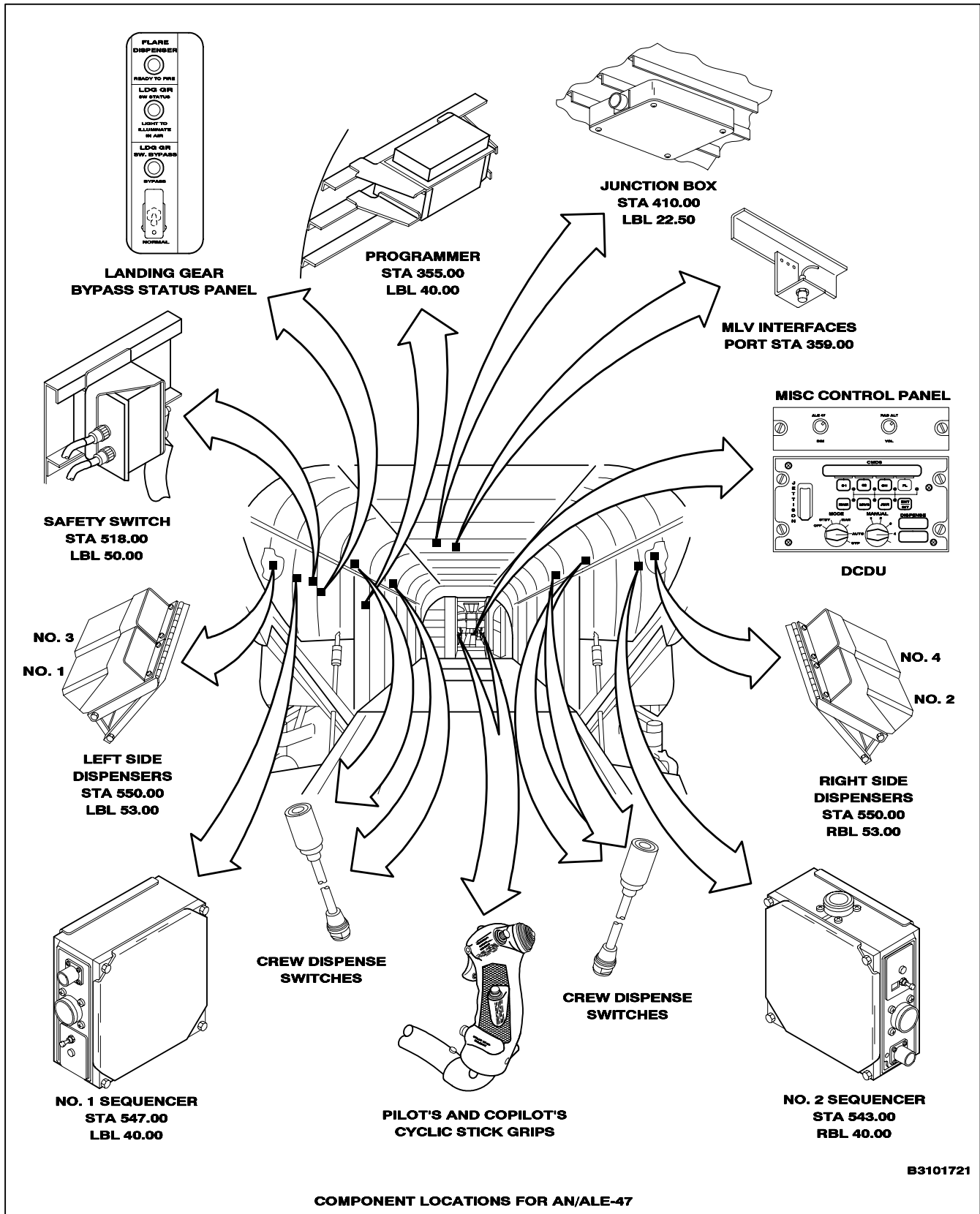

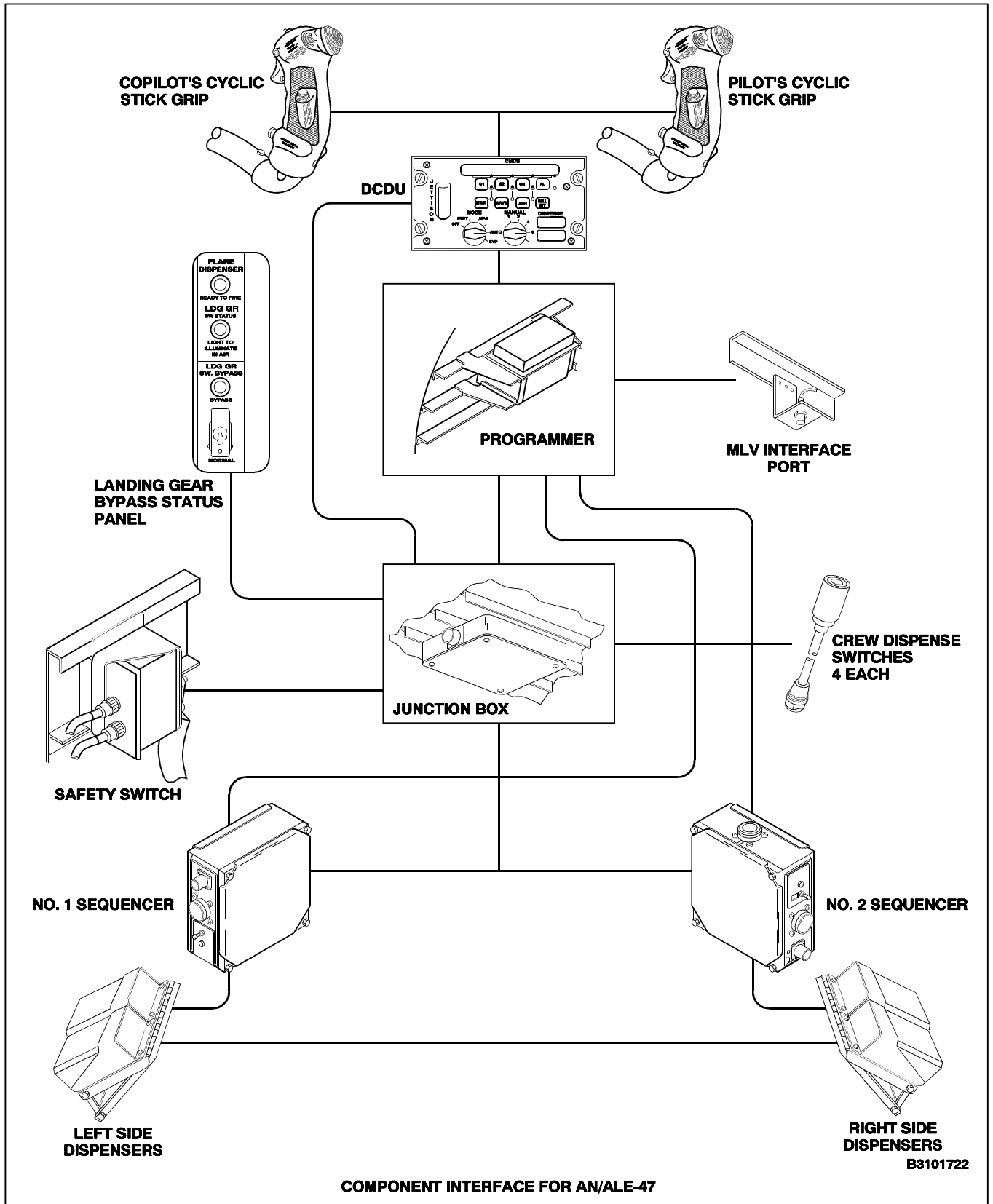

END OF TASK



**SECTION VI.2**  
**AN/ALE-47 COUNTERMEASURES DISPENSER SYSTEM (CMDS)**

INITIAL SETUP

**Applicable Configurations:**

All

**Tools:**

Electronic Equipment Tool Kit, NSN  
5180-00-064-5178

**Materials:**

Paper Tag (E264)

**Personnel Required:**

Avionics Mechanic

**Equipment Condition:**

Battery Disconnected (Task 1-39)  
Electrical Power Off  
Hydraulic Power Off  
AN/ALE-47 Safety Switch Pin Installed (TM  
1-1520-240-10)

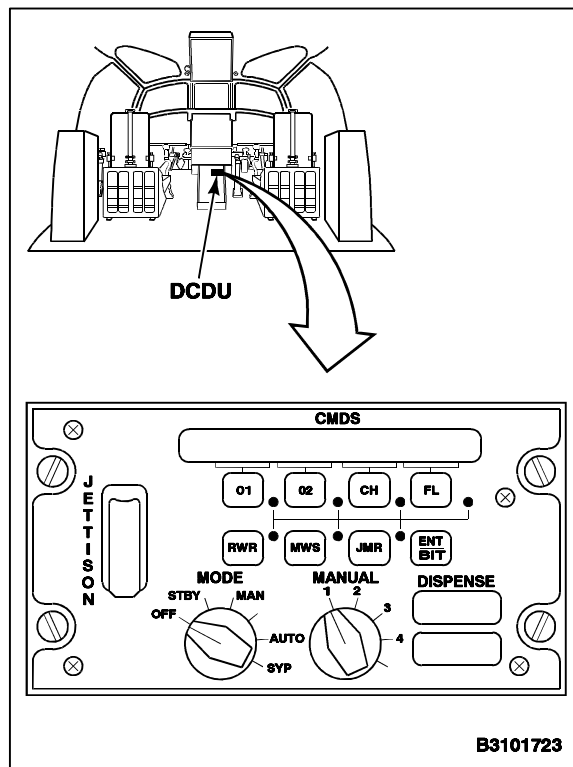

1. Loosen four fasteners (2) on AN/ALE-47 DCDU (3).
2. Lift DCDU (3) from center console (1).
3. Disconnect, tag and cap electrical connector (4) from J1 receptacle on DCDU (3).
4. Remove DCDU (3).

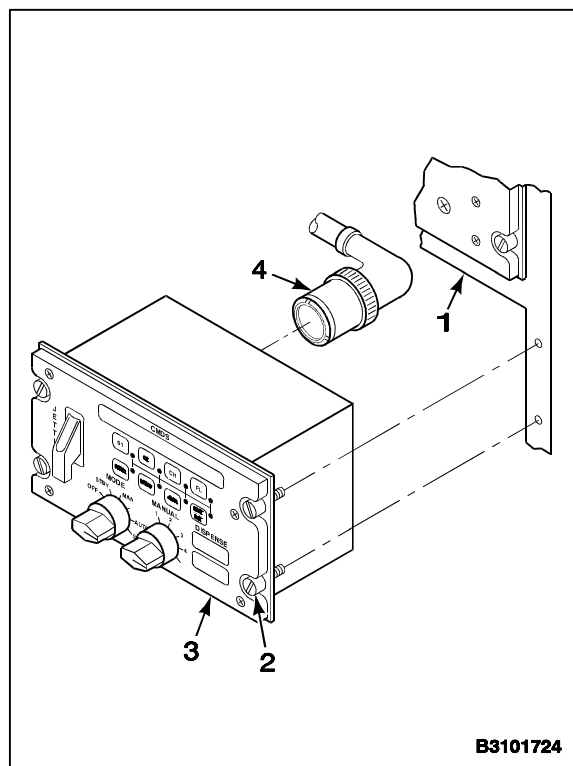

**FOLLOW-ON MAINTENANCE:**

None

END OF TASK

INITIAL SETUP

**Applicable Configurations:**

All

**Tools:**

Electronic Equipment Tool Kit, NSN  
5180-00-064-5178

**Materials:**

None

**Personnel Required:**

Avionics Mechanic  
Inspector

**Equipment Condition:**

Battery Disconnected (Task 1-39)  
Electrical Power Off  
Hydraulic Power Off  
AN/ALE-47 Safety Switch Pin Installed (TM  
1-1520-240-10)  
Miscellaneous Control Panel Removed (Task 16-59.4)

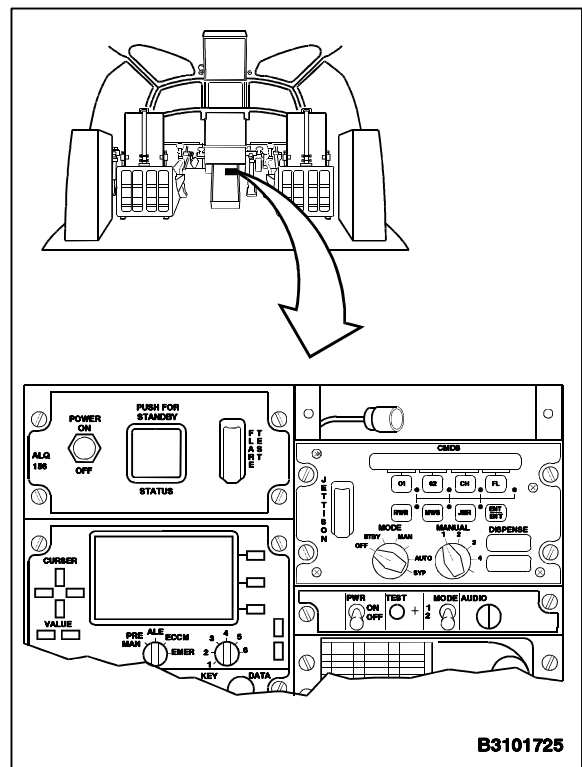

1. Position DCDU (3) in center console (1).
2. Perform bonding check of electrical components per Task 16-59.28.
3. Remove cap and connect electrical connector (4) to J1 receptacle on DCDU (3). Remove tag.
4. Tighten four fasteners (2).

**INSPECT**

**FOLLOW-ON MAINTENANCE:**

Miscellaneous control panel installed (Task 16-59.5).  
Perform operational check of countermeasures dispenser system (TM 55-1520-240-T).

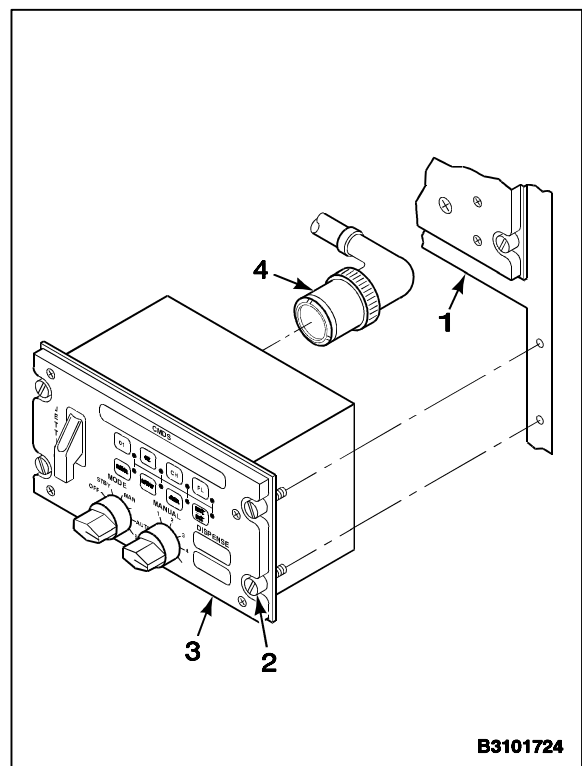

END OF TASK

INITIAL SETUP

**Applicable Configurations:**

All

**Tools:**

Electronic Equipment Tool Kit,  
NSN 5180-00-064-5178

**Materials:**

Paper Tag (E264)

**Personnel Required:**

Avionics Mechanic

**Equipment Condition:**

Battery Disconnected (Task 1-39)  
Electrical Power Off  
Hydraulic Power Off  
AN/ALE-47 Safety Switch Pin Installed  
(TM 1-1520-240-10)

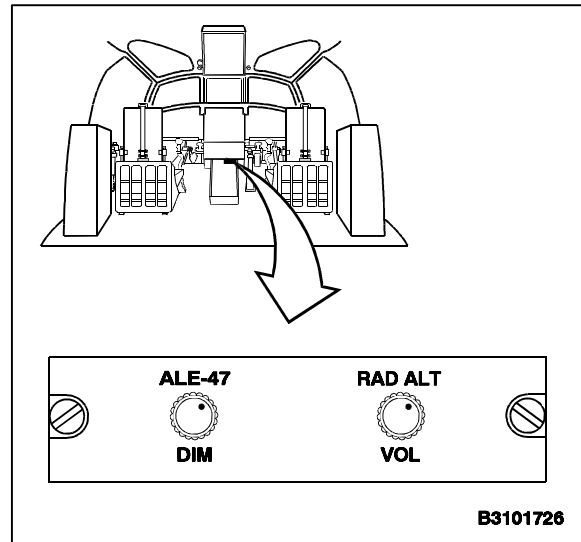

1. Loosen two fasteners (3) on miscellaneous control panel (4).
2. Lift miscellaneous control panel (4) from console (1).
3. Disconnect, tag and cap electrical connector (2) from J1 receptacle on miscellaneous control panel (4).
4. Remove miscellaneous control panel (4).
5. Install blank panel.

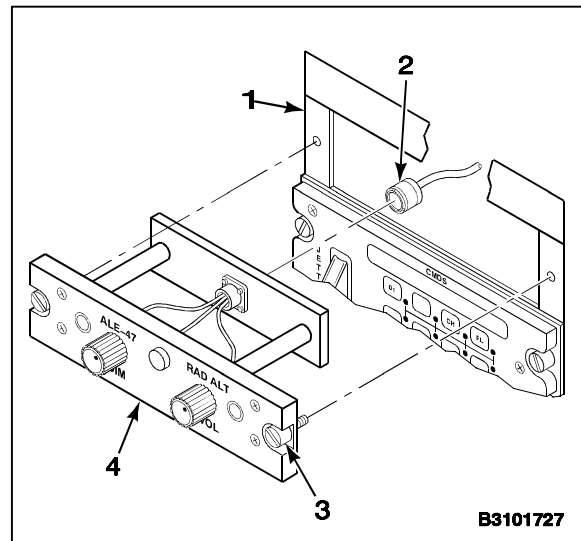

**FOLLOW-ON MAINTENANCE:**

None

END OF TASK



INITIAL SETUP

**Applicable Configurations:**

All

**Tools:**

Electronic Equipment Tool Kit,  
NSN 5180-00-064-5178

**Materials:**

None

**Personnel Required:**

Avionics Mechanic  
Inspector

**Equipment Condition:**

Battery Disconnected (Task 1-39)  
Electrical Power Off  
Hydraulic Power Off  
AN/ALE-47 Safety Switch Pin Installed  
(TM 1-1520-240-10)

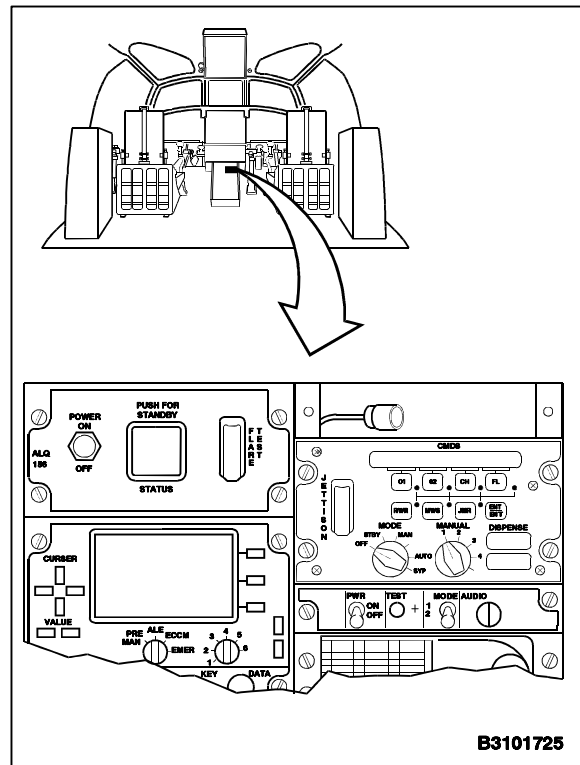

B3101725

1. Remove blank panel if installed.
2. Position miscellaneous control panel (4) on console (1).
3. Perform bonding check of electrical components per Task 16-59.28.
4. Remove cap and connect electrical connector (2) to J1 receptacle on miscellaneous control panel (4). Remove tag.
5. Tighten two fasteners (3).

**INSPECT**

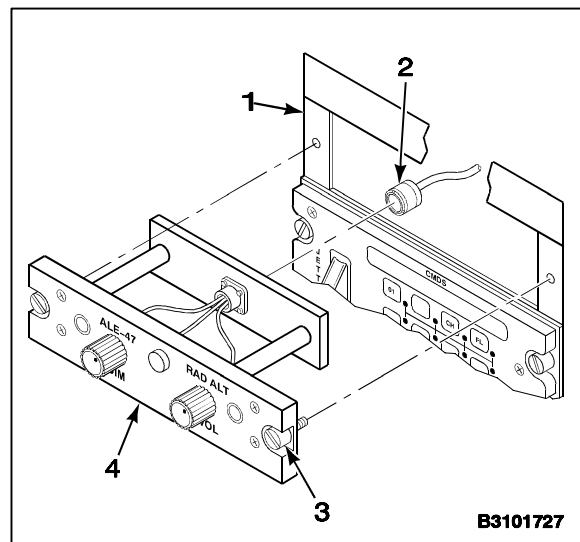

B3101727

**FOLLOW-ON MAINTENANCE:**

Perform operational check of countermeasures dispenser system (TM 55-1520-240-T).

END OF TASK

## INITIAL SETUP

**Applicable Configurations:**

All

**Tools:**

Electronic Equipment Tool Kit,  
NSN 5180-00-064-5178

**Materials:**

Paper Tag (E264)

**Personnel Required:**

Avionics Mechanic

**Equipment Condition:**

Battery Disconnected (Task 1-39)  
Electrical Power Off  
Hydraulic Power Off  
AN/ALE-47 Safety Switch Pin Installed  
(TM 1-1520-240-10)  
Remove Cabin Acoustic Blanket (Task 2-208)

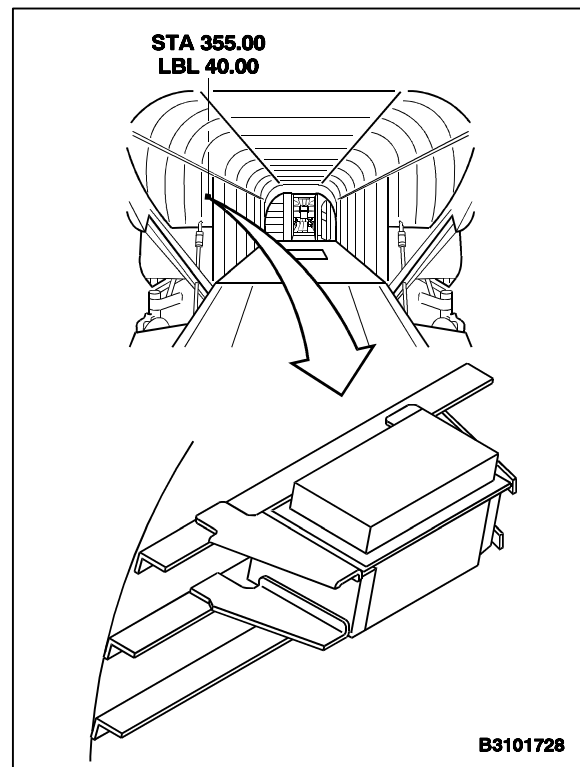

1. Disconnect, tag and cap two electrical connectors (3 and 4) from J1 and J2 receptacles on AN/ALE-47 programmer (1).



Support programmer while removing fasteners. Failure to comply may result in damage to programmer.

2. Loosen four fasteners (5) securing programmer (1) to mounting brackets (2).
3. Lift programmer (1) out of mounting brackets (2).

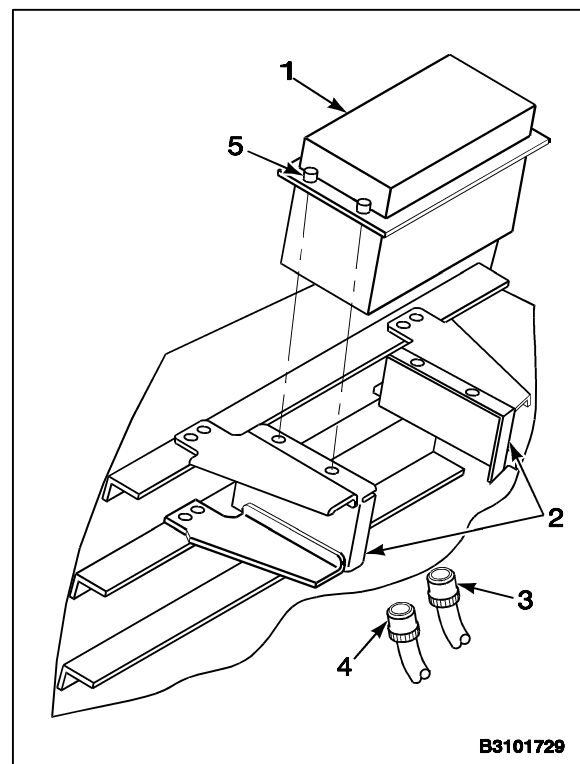
**FOLLOW-ON MAINTENANCE:**

None

## END OF TASK

## INITIAL SETUP

**Applicable Configurations:**

All

**Tools:**Electronic Equipment Tool Kit,  
NSN 5180-00-064-5178**Materials:**

None

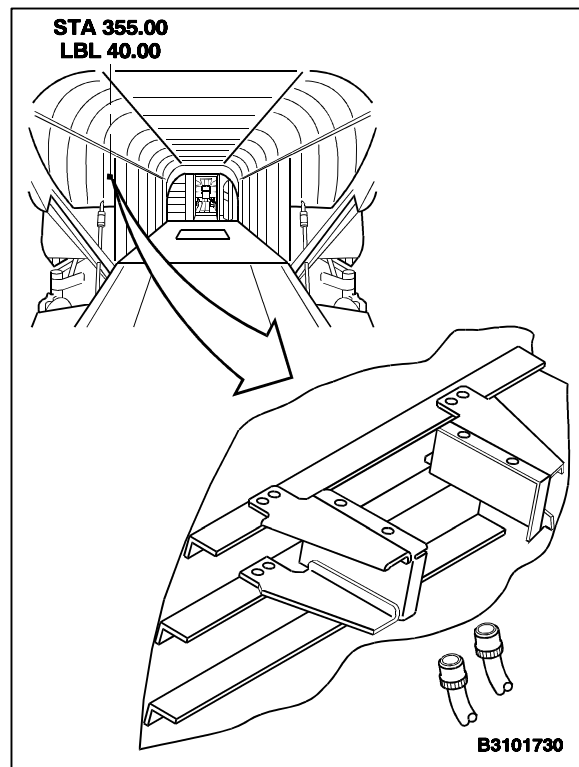
**Personnel Required:**Avionics Mechanic  
Inspector**Equipment Condition:**Battery Disconnected (Task 1-39)  
Electrical Power Off  
Hydraulic Power Off  
AN/ALE-47 Safety Switch Pin Installed  
(TM 1-1520-240-10)

1. Position AN/ALE-47 programmer (1) onto mounting brackets (2) and secure in place with four fasteners (5).
2. Perform bonding check of electrical components per Task 16-59.28.
3. Remove caps and connect two electrical connectors (3 and 4) to J1 and J2 receptacles on AN/ALE-47 programmer (1). Remove tag.

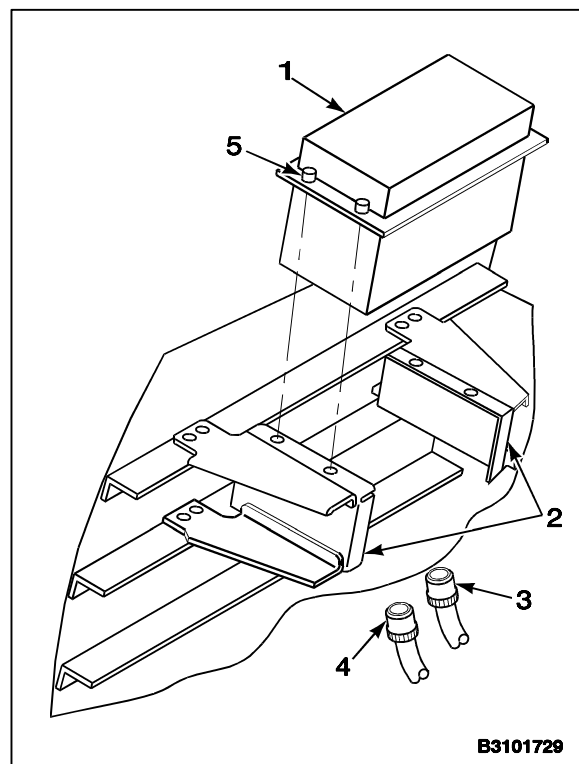
**INSPECT****FOLLOW-ON MAINTENANCE:**Perform operational check of countermeasures  
dispenser system (TM 55-1520-240-T).  
Install cabin acoustic blanket (Task 2-210).

END OF TASK

INITIAL SETUP

**Applicable Configurations:**

All

**Tools:**

Electronic Equipment Tool Kit,  
NSN 5180-00-064-5178

**Materials:**

Paper Tag (E264)

**Personnel Required:**

Avionics Mechanic

**Equipment Condition:**

Battery Disconnected (Task 1-39)  
Electrical Power Off  
Hydraulic Power Off  
Cargo Ramp Open and Level (TM 55-1520-240-T)  
AN/ALE-47 Safety Switch Pin Installed  
(TM 1-1520-240-10)

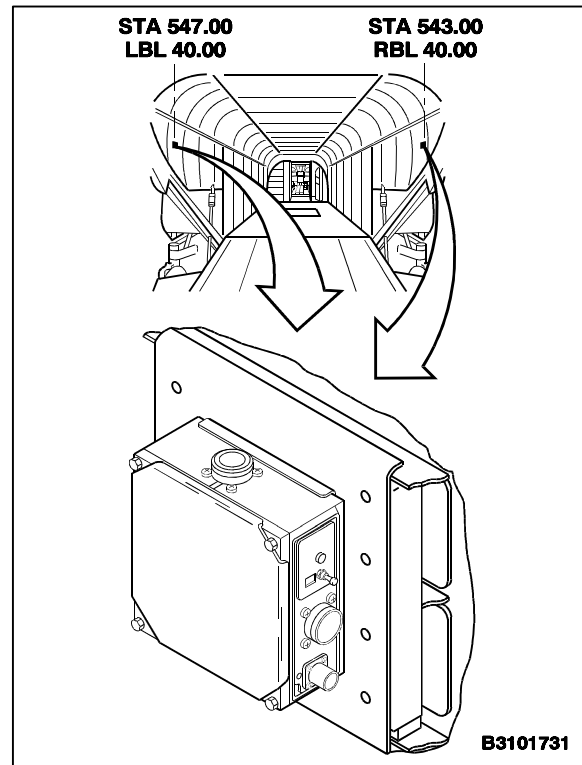

**NOTE**

Procedures for removing the LH and RH sequencers are the same.

1. Disconnect, tag and cap two electrical connectors (5 and 7) from J1 and J3 receptacles on sequencer (6).



Support sequencer while removing screws. Failure to comply may result in damage to sequencer or cables.

2. Remove eight screws (8) and washers (9) securing sequencer mounting plate (4) to mounting bracket (1).
3. Remove four screws (2) and washers (3) securing sequencer (6) to mounting plate (4).
4. Remove sequencer (6).

**FOLLOW-ON MAINTENANCE:**

None

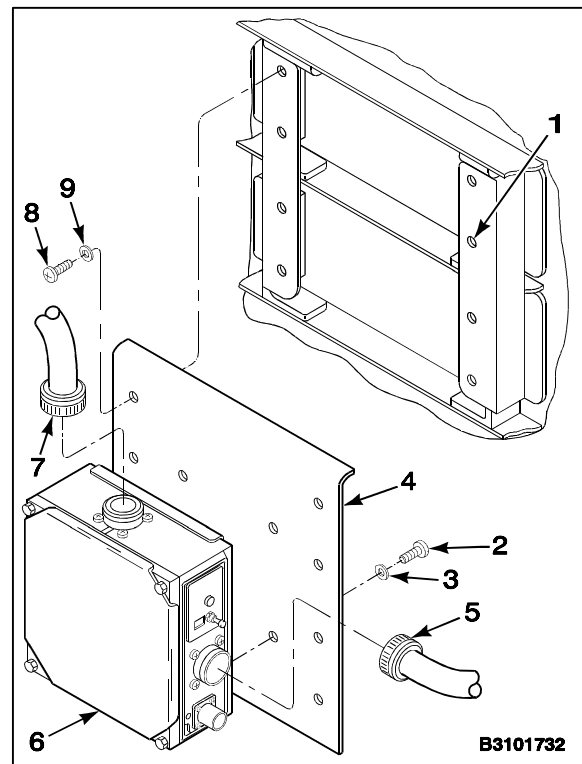

END OF TASK

INITIAL SETUP

**Applicable Configurations:**

All

**Tools:**

Electronic Equipment Tool Kit,  
NSN 5180-00-064-5178

**Materials:**

Lockwire (E229)

**Personnel Required:**

Avionics Mechanic  
Inspector

**Equipment Condition:**

Battery Disconnected (Task 1-39)  
Electrical Power Off  
Hydraulic Power Off  
AN/ALE-47 Safety Switch Pin Installed  
(TM 1-1520-240-10)

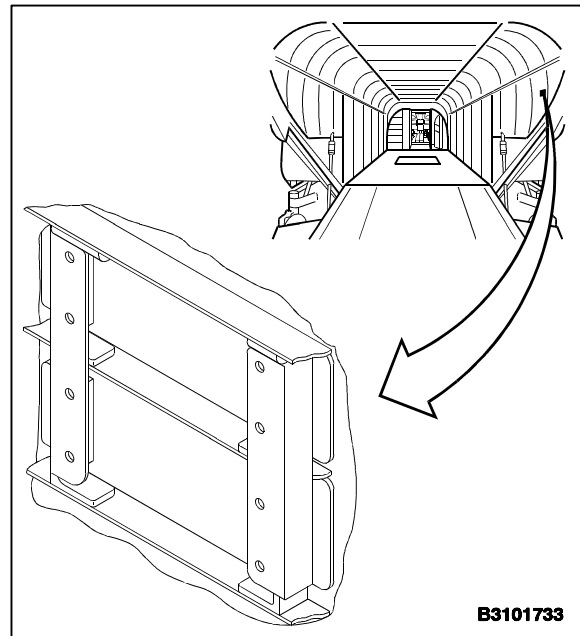

B3101733

**NOTE**

Procedures to install the LH and RH sequencers are the same.

1. Position sequencer (6) on mounting plate (4) and secure with four screws (2) and washers (3).
2. Position sequencer mounting plate (4) and sequencer (6) to the mounting bracket (1) and secure with eight screws (8) and washers (9).
3. Perform bonding check of electrical components per Task 16-59.28.
4. Remove caps and connect two electrical connectors (5 and 7) to J1 and J3 receptacles on sequencer (6). Remove tag.

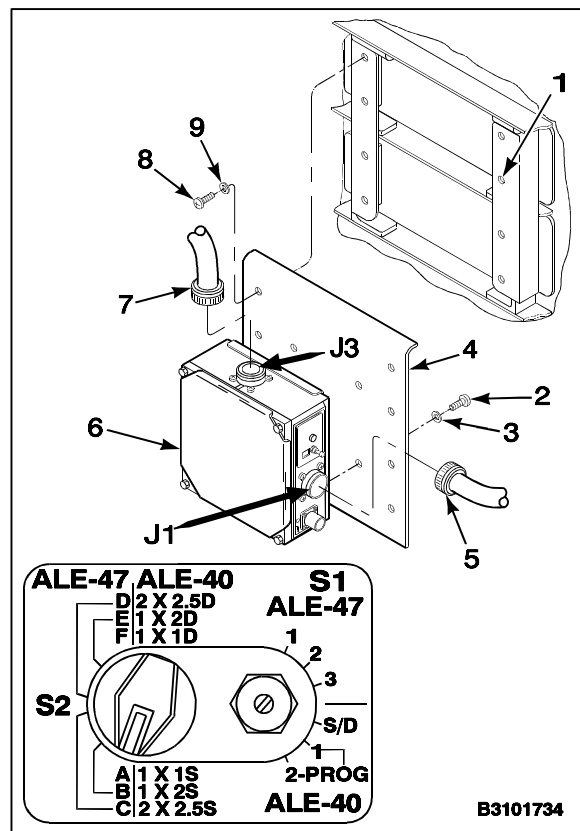

B3101734

**NOTE**

Ensure sequencer switches are set as follows:  
LH (No. 1) Sequencer — 1A  
RH (No. 2) Sequencer — 2A  
Graphic depicts setup for No. 2 sequencer.

5. Safety wire sequencer switches using lockwire (E229).

**INSPECT**

**FOLLOW-ON MAINTENANCE:**

Perform operational check of countermeasures dispenser system (TM 55-1520-240-T).  
Close cargo ramp (TM 55-1520-240-T).

END OF TASK

## INITIAL SETUP

**Applicable Configurations:**

All

**Tools:**Electronic Equipment Tool Kit,  
NSN 5180-00-064-5178**Materials:**

Paper Tag (E264)

**Personnel Required:**

Avionics Mechanic

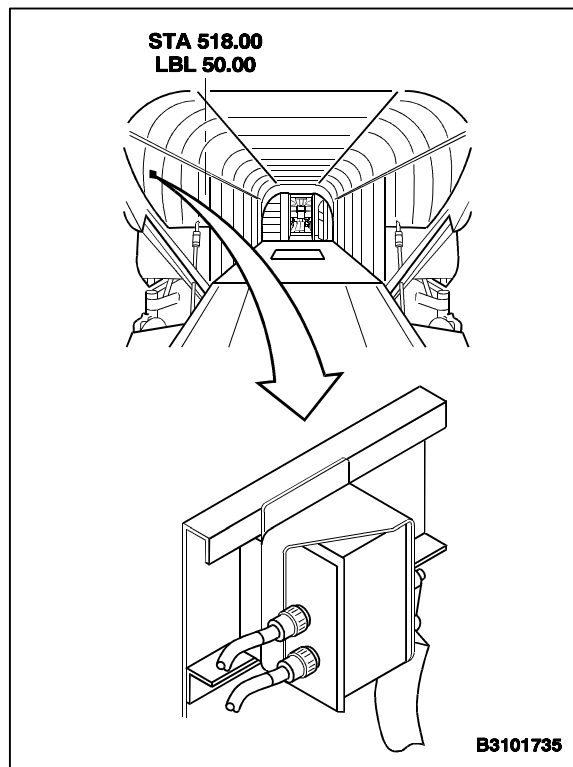
**Equipment Condition:**Battery Disconnected (Task 1-39)  
Electrical Power Off  
Hydraulic Power Off

Support safety switch while removing screws. Failure to comply may result in damage to programmer.

1. Disconnect, tag and cap two electrical connectors (6), from J1 and J2 receptacles on AN/ALE-47 safety switch (5).
2. Remove safety pin (1) from safety switch (5).
3. Remove three screws (2) and washers (3) securing safety switch (5) to mounting bracket (4).
4. Slide safety switch (5) out of mounting bracket (4).

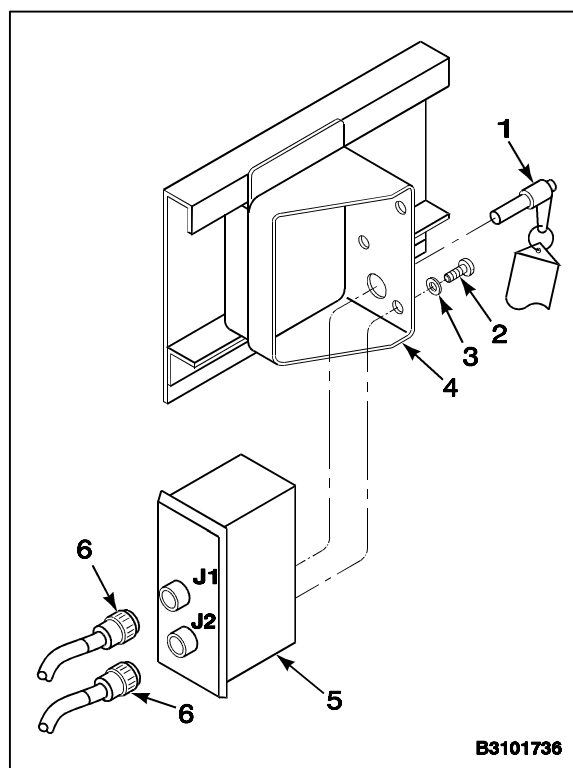
**FOLLOW-ON MAINTENANCE:**

None

## END OF TASK

**16-59.11 INSTALL AN/ALE-47 SAFETY SWITCH**

16-59.11

**INITIAL SETUP****Applicable Configurations:**

All

**Tools:**Electronic Equipment Tool Kit,  
NSN 5180-00-064-5178**Materials:**

None

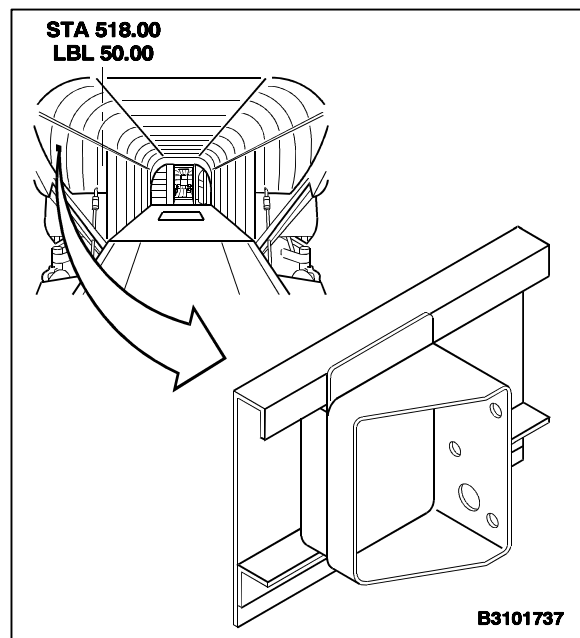
**Personnel Required:**Avionics Mechanic  
Inspector**Equipment Condition:**Battery Disconnected (Task 1-39)  
Electrical Power Off  
Hydraulic Power Off

1. Position AN/ALE-47 safety switch (5) into mounting bracket (4) and secure in place with three screws (2) and washers (3).
2. Perform bonding check of electrical components per Task 16-59.28.
3. Remove caps and connect two electrical connectors (6) to J1 and J2 receptacles on AN/ALE-47 safety switch (5). Remove tag.
4. Install safety pin (1) in safety switch (5).

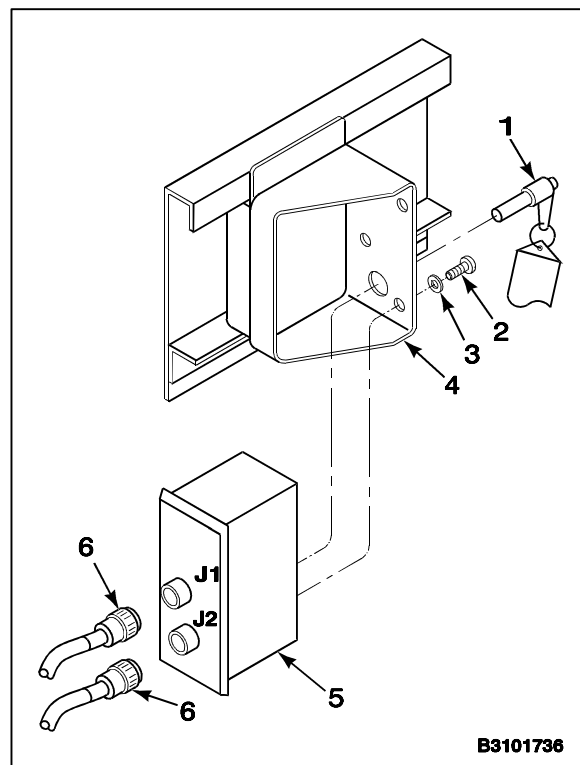
**INSPECT****FOLLOW-ON MAINTENANCE:**Perform operational check of countermeasures  
dispenser system (TM 55-1520-240-T).

END OF TASK

## INITIAL SETUP

**Applicable Configurations:**

All

**Tools:**Electronic Equipment Tool Kit,  
NSN 5180-00-064-5178**Materials:**

None

**Personnel Required:**

Avionics Mechanic

**Equipment Condition:**Battery Disconnected (Task 1-39)  
Electrical Power Off  
Hydraulic Power Off  
AN/ALE-47 Safety Switch Pin Installed  
(TM 1-1520-240-10)**General Safety Instructions:****WARNING**

Ensure battery is disconnected and electrical power is off. Ensure LDG GR SW BYPASS switch on landing gear bypass panel is in NORMAL and AN/ALE-47 safety switch pin is installed. Failure to comply could result in death or injury to personnel or damage to equipment.

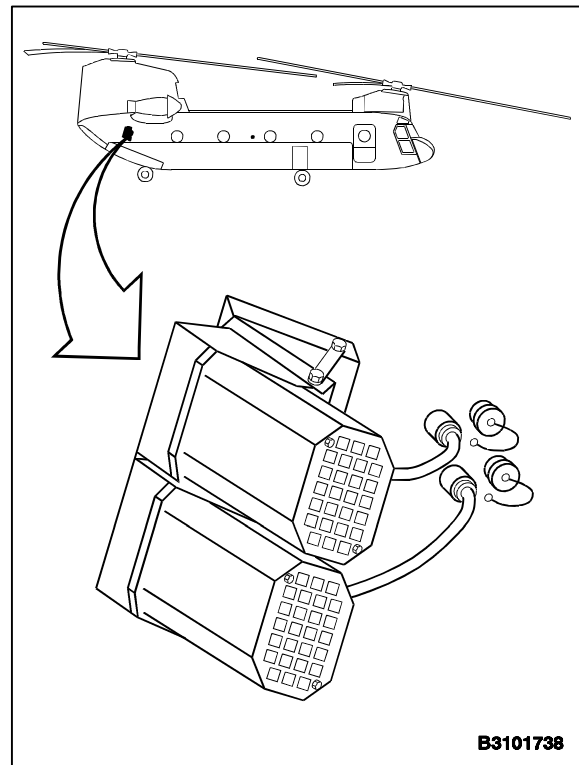



**WARNING**

Keep face and hands away from front of payload module during removal. Failure to comply may result in death or injury to personnel.

**NOTE**

Procedures to remove all four payload modules are the same.

1. Loosen two bolts (1) from payload module (2).
2. Slide payload module (2) out from dispenser assembly (3).

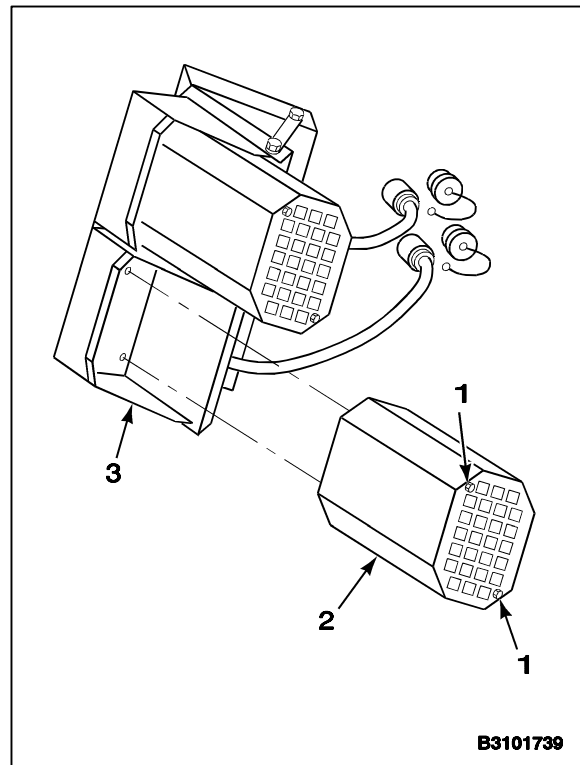
**FOLLOW-ON MAINTENANCE:**

None

END OF TASK

## INITIAL SETUP

**Applicable Configurations:**

All

**Tools:**Electronic Equipment Tool Kit,  
NSN 5180-00-064-5178**Materials:**

None

**Personnel Required:**Avionics Mechanic  
Inspector**Equipment Condition:**Battery Disconnected (Task 1-39)  
Electrical Power Off  
Hydraulic Power Off  
AN/ALE-47 Safety Switch Pin Installed  
(TM 1-1520-240-10)**General Safety Instructions:****WARNING**

Ensure battery is disconnected and electrical power is off. Ensure LDG GR SW BYPASS switch on landing gear bypass panel is in NORMAL and AN/ALE-47 safety switch pin is installed. Failure to comply could result in death or injury to personnel or damage to equipment.

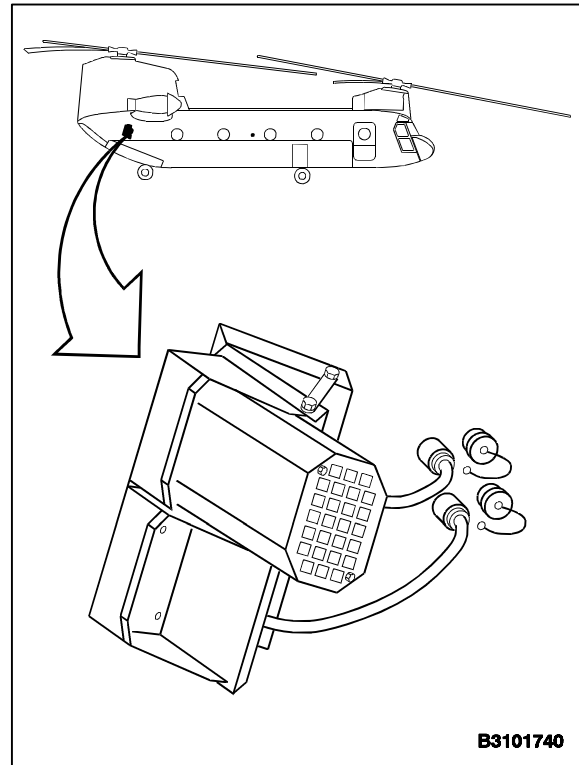

B3101740

**NOTE**

Procedures to install all four payload modules are the same.

1. Position payload module (2) into dispenser assembly (3).
2. Torque bolts (1) to **40-50 inch-pounds** evenly to ensure payload module is properly seated in dispenser assembly.
3. Perform bonding check of electrical components per Task 16-59.28.

**WARNING**

Keep face and hands away from front of payload module during removal. Failure to comply may result in death or injury to personnel.

**INSPECT****FOLLOW-ON MAINTENANCE:**

Perform operational check of countermeasures dispenser system (TM 55-1520-240-T).

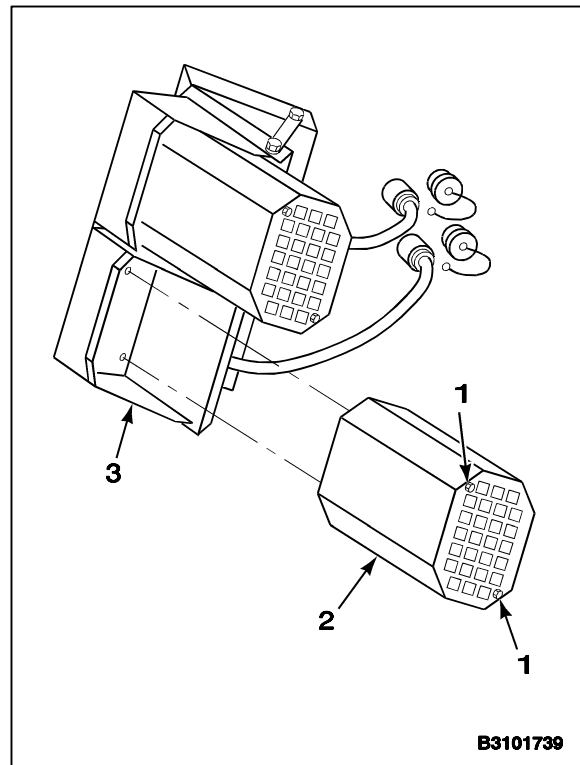

END OF TASK

INITIAL SETUP

**Applicable Configurations:**

All

**Tools:**

Electronic Equipment Tool Kit,  
NSN 5180-00-064-5178

**Materials:**

Flare, Aircraft: Countermeasure, XM211  
Flare, Aircraft: Countermeasure, XM212  
Flare, Aircraft: Countermeasure, M206

**Personnel Required:**

Avionics Mechanic

**Equipment Condition:**

Payload Module Removed (Task 16-59.12)

**General Safety Instructions:**



Missions in a threat environment require the AN/ALE-47 Countermeasure Dispenser System be loaded with Advanced Infrared Countermeasures Munitions (AIRCMM) flare combination. The dispenser is divided into 3 zones and each zone is loaded with 10 of the same type flares. A correctly loaded dispenser will have an equal number of M206, XM211, and XM212 Aircraft Countermeasure Flares. This combination provides optimal countermeasure capability. Deviations from this AIRCMM flare combination will significantly reduce countermeasure capability and increase aircrew vulnerability to Infrared (IR) missile threats. Aircraft shall not be flown into threat environments with any combination of flares other than this AIRCMM flare solution unless authorized by the unit commander. Failure to comply could result in death or injury to personnel or damage to equipment.

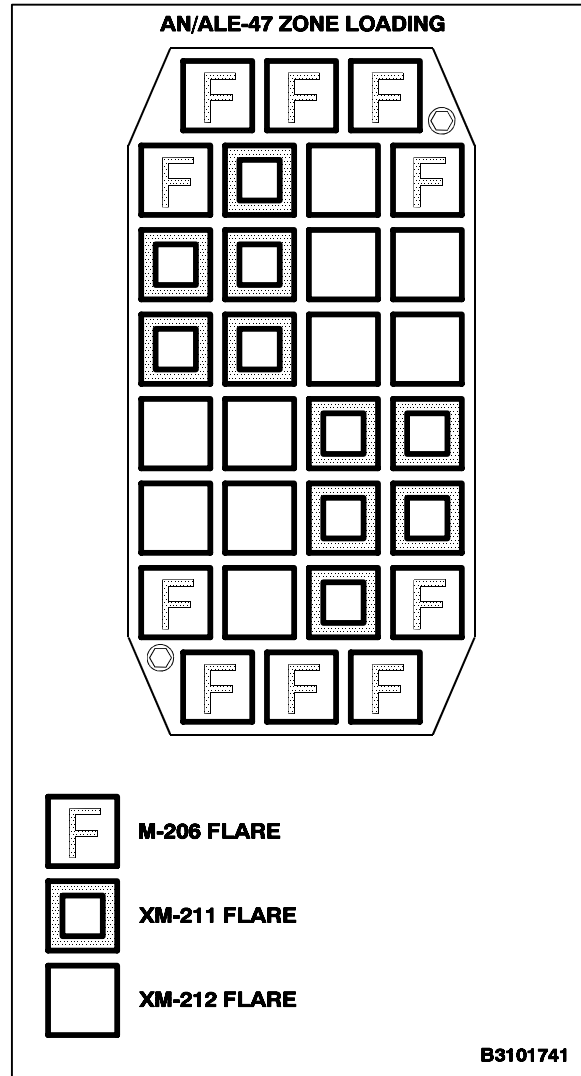

Viewed from the front of the payload module looking at the flare end caps.

1. Place payload module assembly (2) so that retaining plate (3) is facing upward.
2. Remove two retaining screws (1) securing retaining plate to payload module. Remove retaining plate (3).

**WARNING**

Chaff, flare, or impulse cartridges that exhibit any sign of visible damage, or have been subjected to rough handling, will not be loaded into payload module assemblies. Unserviceable chaff, flare, or impulse cartridges will be disposed of by EOD personnel. Chaff or flare cartridges shall not be hammered or forced into payload module assemblies. Failure to comply could result in death or injury to personnel or damage to equipment.

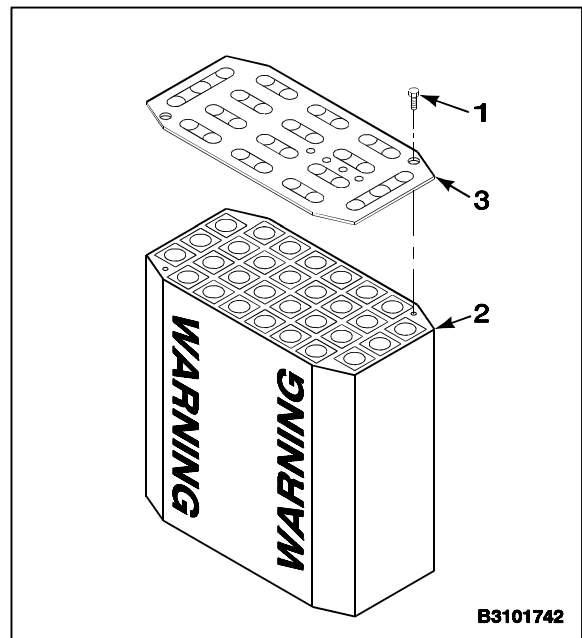

**WARNING**

Chaff and flare cartridges shall not be mix loaded in a payload module assembly. Flare cartridges will not be loaded in aircraft specified for chaff configurations only. Failure to comply could result in death or injury to personnel or damage to equipment.

**NOTE**

Refer to AN/ALE-47 Zone Loading Illustration for flare cartridge configuration.

3. Insert flare cartridges (5) into payload module assembly (2) chambers using hand pressure.
4. Remove plastic dust caps (6) from each flare cartridge, making sure that O-ring (4) remains installed on the flare cartridge.

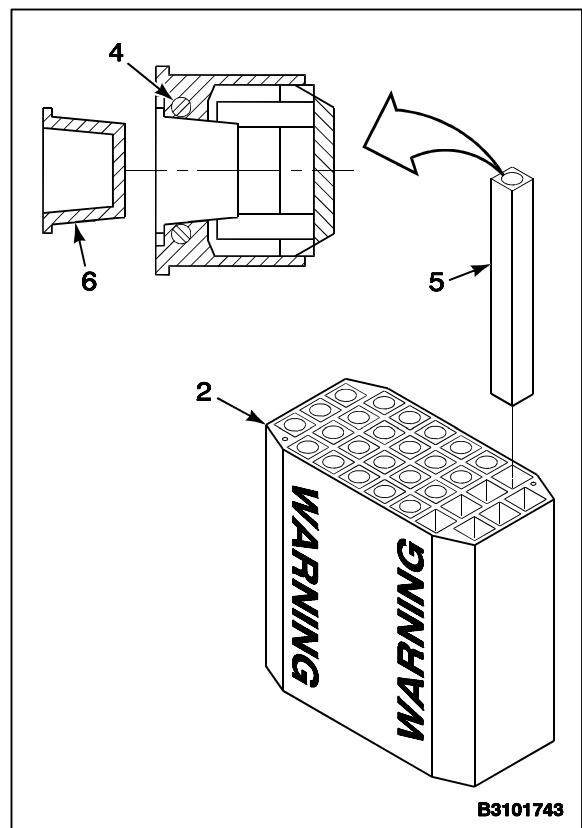

**NOTE**

For flare types M206 and M212, skip steps 5 thru 8.

For flare type M211, skip steps 9 and 10.

**NOTE**

String is used to allow air trapped in squib cup to be released during installation of impulse cartridge.

Strings are attached to underside of PA19 Ammo Can lid.

5. Put one end of string (8) into flare cartridge (5) squib cup.
6. Insert one impulse cartridge (7) into each squib cup and install using thumb pressure.
7. Holding impulse cartridge in place, slowly pull string (8) out of squib cup. Ensure impulse cartridge (7) is not pulled from squib cup as string is pulled out.
8. If impulse cartridge is not seated properly, remove and repeat steps 5 thru 7.

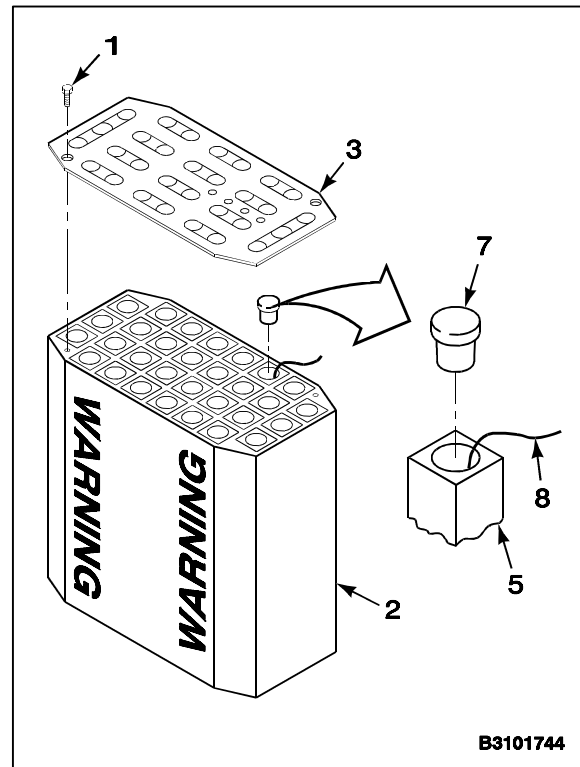

- Insert one impulse cartridge (7) into each flare cartridge (5) in the payload module assembly (2).

**NOTE**

Refer to table below to determine position of encoder pins in retaining plate.

"X" = Coding Pin Installed

"O" = Coding Pin Not Installed

- Insert encoder pin screws (10) into appropriate holes (S2, S3, S4, S5) from payload module side of retaining plate.

DISP. NO.	AIRCRAFT LOCATION	MAG ID	ENCODER PIN LOCATION			
			S2	S3	S4	S5
1	LH LOWER	1	X	O	O	O
2	RH LOWER	8	O	O	O	X
3	LH UPPER	1	X	O	O	O
4	RH UPPER	8	O	O	O	X

- Install encoder pins (9) onto encoder pin screws (10); tighten screws.
- Align retaining plate (3) over payload module (2).



Over-tightening retaining plate screws may cause retaining plate to warp resulting in erroneous flare counts or misfires.

- While maintaining even hand pressure on retaining plate (3) to prevent warping or buckling, secure retaining plate with two screws (1).

**FOLLOW-ON MAINTENANCE:**

Install AN/ALE-47 payload modules per Task 16-59.13.

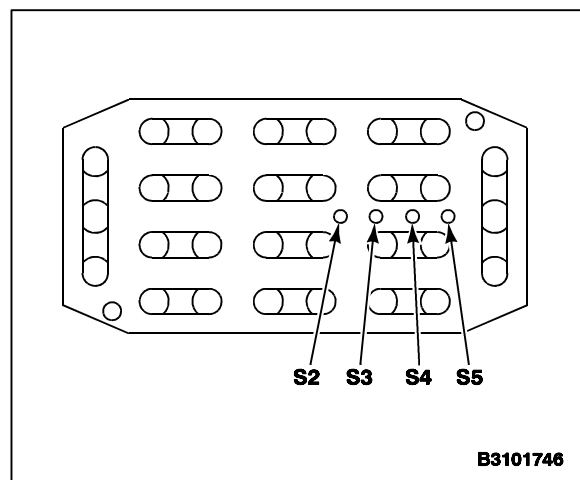
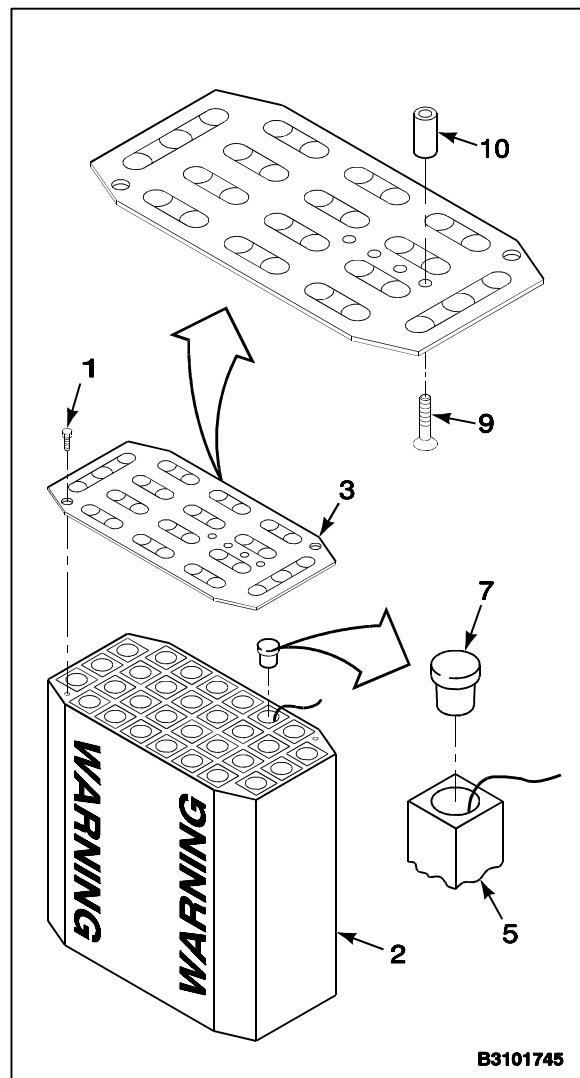

END OF TASK

## INITIAL SETUP

**Applicable Configurations:**

All

**Tools:**Electronic Equipment Tool Kit,  
NSN 5180-00-064-5178**Materials:**Flare, Aircraft: Countermeasure, XM211  
Flare, Aircraft: Countermeasure, XM212  
Flare, Aircraft: Countermeasure, M206**Personnel Required:**

Avionics Mechanic

**Equipment Condition:**

Payload Module Removed (Task 16-59.12)

**General Safety Instructions:****WARNING**

Unexpended or misfired chaff, flare, or impulse cartridges that exhibit any sign of visible damage, or have been subjected to rough handling, will not be reused. Unserviceable chaff, flare, or impulse cartridges will be disposed of by EOD personnel. Failure to comply could result in death or injury to personnel or damage to equipment.

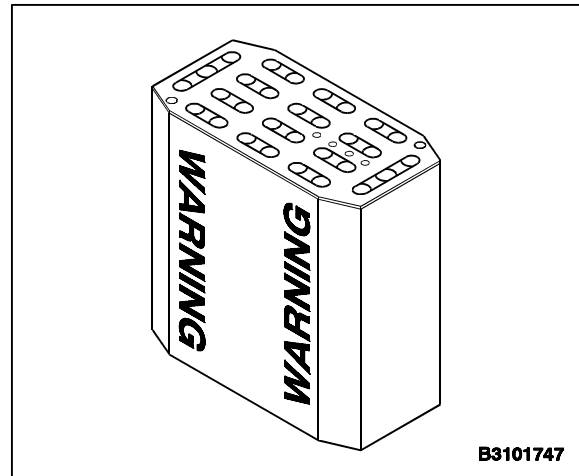



**WARNING**

If there is an indication that a misfire occurred, notify EOD personnel for disposal after removal. Failure to comply could result in death or injury to personnel or damage to equipment.

1. Place payload module assembly (5) so that retaining plate (2) is facing up.
2. Remove two screws (1) securing retaining plate (2) to payload module assembly (5). Remove retaining plate (2).



Use care when removing impulse cartridges and flares to prevent damage to payload module or flare decals.

3. Remove impulse cartridges (3) from unexpended flares (4).
4. Remove flares (4) from payload module (5).
5. Inspect unexpended flares and impulse cartridges for serviceability prior to storage. If flares or cartridges are found to be unserviceable, notify EOD personnel for disposal.

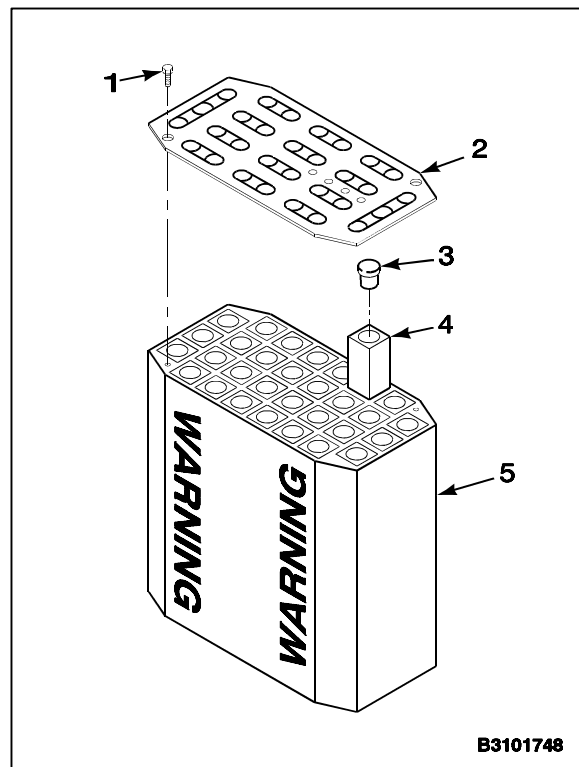
**FOLLOW-ON MAINTENANCE:**

Install payload module (Task 16-59.13).

END OF TASK

INITIAL SETUP

**Applicable Configurations:**

All

**Tools:**

Electronic Equipment Tool Kit,  
NSN 5180-00-064-5178

**Materials:**

Paper Tag (E264)

**Personnel Required:**

Avionics Mechanic

**Equipment Condition:**

- Battery Disconnected (Task 1-39)
- Electrical Power Off
- Hydraulic Power Off
- AN/ALE-47 Safety Switch Pin Installed  
(TM 1-1520-240-10)
- LDG GR SW Bypass Switch in Normal  
(TM 1-1520-240-10)

**General Safety Instructions:**

**WARNING**

Ensure battery is disconnected and electrical power is off. Ensure LDG GR SW BYPASS switch on landing gear bypass panel is in NORMAL and AN/ALE-47 safety switch pin is installed. Failure to comply could result in death or injury to personnel or damage to equipment.

**NOTE**

Procedures to remove all dispenser assemblies are the same.

1. Remove both payload modules per Task 16-59.12.
2. Tag, cap and disconnect electrical plug (3) from fuselage connector (4).
3. Disconnect protective cap (2) from stowage receptacle (1); install cap on fuselage connector (4).

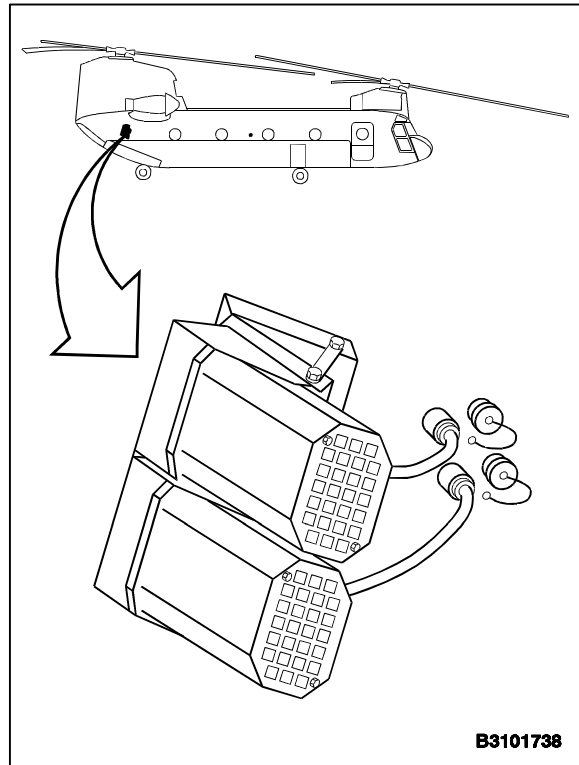

B3101738

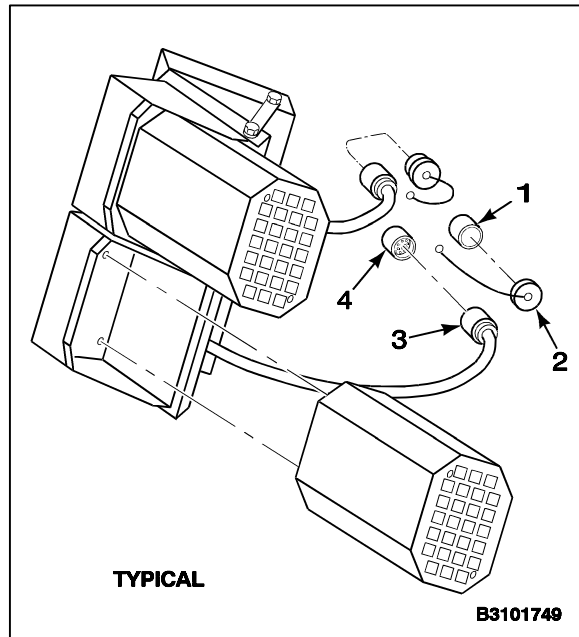

TYPICAL

B3101749

4. Remove two bolts (8), washers (9), and nuts (10) from outboard ends of dispenser assembly mount arms (7).
5. Disconnect electrical plug (11) from dispenser assembly connector (5).
6. Remove four bolts (14) and washers (13) from dispenser assembly (12); remove dispenser assembly (12) from dispenser assembly mount (6).

**NOTE**

If dispenser is not going to be installed, perform step 7.

7. Reinstall two bolts (8), washers (9), and nuts (10) into outboard ends of dispenser assembly mount arms (7).

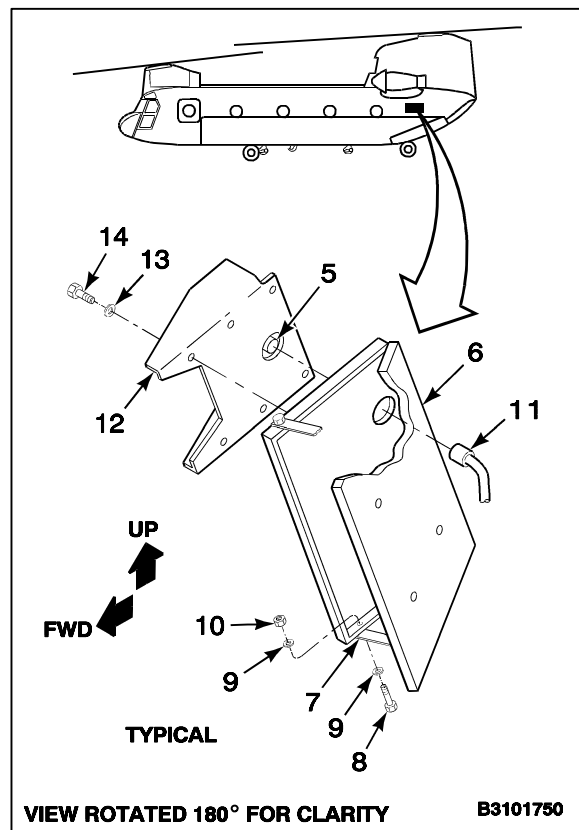
**FOLLOW-ON MAINTENANCE:**

None

END OF TASK

## INITIAL SETUP

**Applicable Configurations:**

All

**Tools:**

Electronic Equipment Tool Kit,  
NSN 5180-00-064-5178  
Torque Wrench, 5-150 Inch-Pounds

**Materials:**

None

**Personnel Required:**

Avionics Mechanic  
Inspector

**Equipment Condition:**

Battery Disconnected (Task 1-39)  
Electrical Power Off  
Hydraulic Power Off  
AN/ALE-47 Safety Switch Pin Installed  
(TM 1-1520-240-10)  
LDG GR SW Bypass Switch in Normal  
(TM 1-1520-240-10)

**General Safety Instructions:****WARNING**

Ensure battery is disconnected and electrical power is off. Ensure LDG GR SW BYPASS switch on landing gear bypass panel is in NORMAL and AN/ALE-47 safety switch pin is installed. Failure to comply could result in death or injury to personnel or damage to equipment.

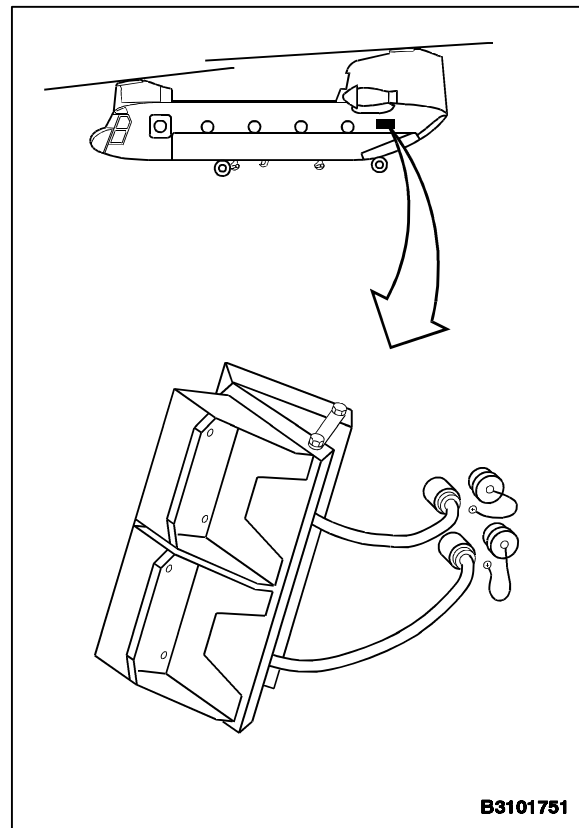

B3101751

**NOTE**

Procedures to install all dispenser assemblies are the same.

Install connectors/plugs per the following:

CONNECTOR OR PLUG	LOCATION
J41	LH Fuselage Upper
J44	LH Fuselage Lower
J47	RH Fuselage Upper
J50	RH Fuselage Lower
P42	LH Upper Dispenser # 3
P45	LH Lower Dispenser # 1
P48	RH Upper Dispenser # 4
P51	RH Lower Dispenser # 2

1. Position dispenser assembly (8) on mount (2); install four bolts (10) and washers (9).



An over-torque of bolts can cause a failure in retaining the dispenser assembly during flight and flare dispensing.

2. Torque bolts (10) to **60 inch-pounds**.
3. Perform bonding check of electrical components per Task 16-59.28.
4. Connect electrical plug (7) to dispenser assembly connector (1).
5. Install bolts (4), washers (5), and nuts (6) onto dispenser assembly arms (3).
6. Remove protective cap (12) from connector (14); install cap on receptacle (11).
7. Install electrical plug (13) onto fuselage connector (14).
8. Install payload modules per Task 16-59.13.

**INSPECT**

**FOLLOW-ON MAINTENANCE:**

Perform operational check of countermeasures dispenser system (TM 55-1520-240-T).

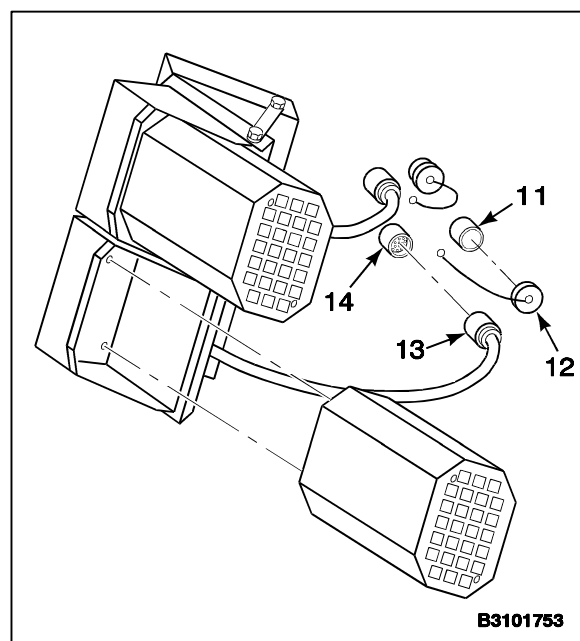
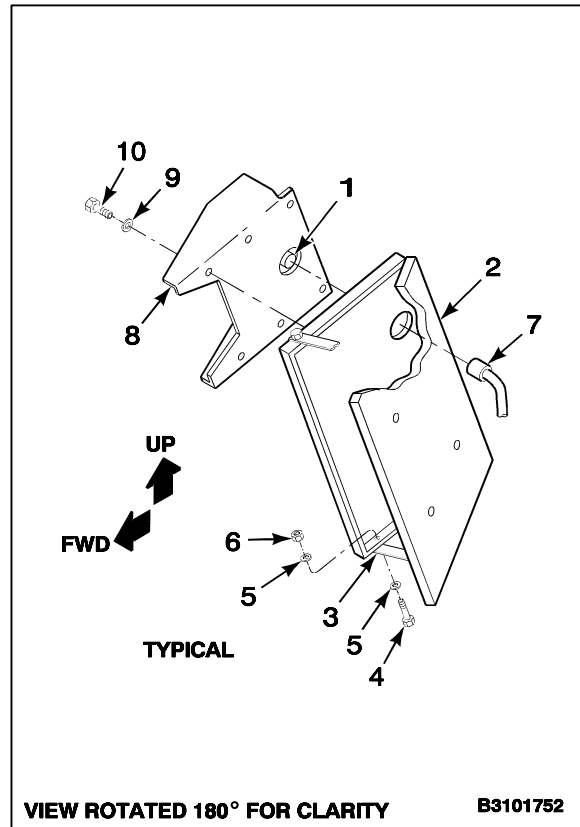

END OF TASK

## INITIAL SETUP

**Applicable Configurations:**

All

**Tools:**Electronic Equipment Tool Kit,  
NSN 5180-00-064-5178**Materials:**

None

**Personnel Required:**

Avionics Mechanic

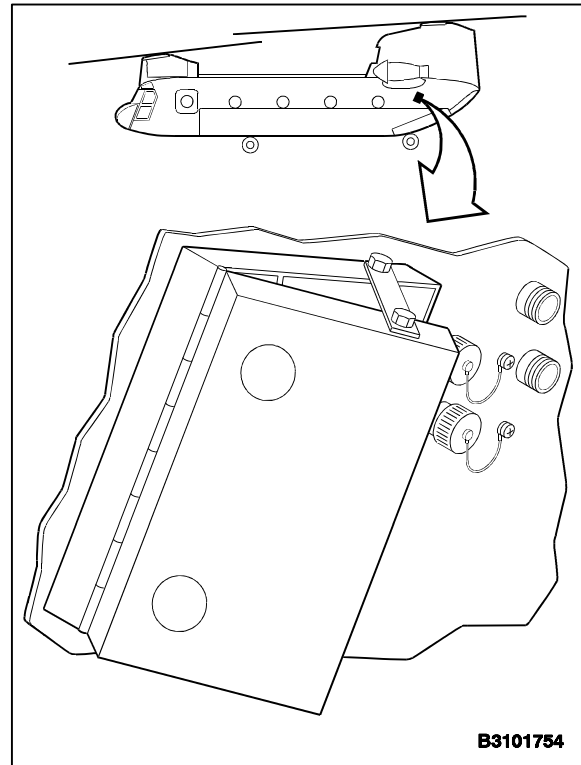
**Equipment Condition:**Battery Disconnected (Task 1-39)  
Electrical Power Off  
Hydraulic Power Off  
AN/ALE-47 Safety Switch Pin Installed  
(TM 1-1520-240-10)  
LDG GR SW Bypass Switch in Normal  
(TM 1-1520-240-10)  
Payload Modules Removed (Task 16-59.12)  
Dispenser Assembly Removed (Task 16-59.16)

B3101754

**NOTE**

Procedures to remove left and right dispenser assembly mounts are the same.

1. Remove four bolts (2) and washers (1) securing dispenser assembly mount (3) to fuselage.
2. Remove dispenser assembly mount (3) from aircraft.

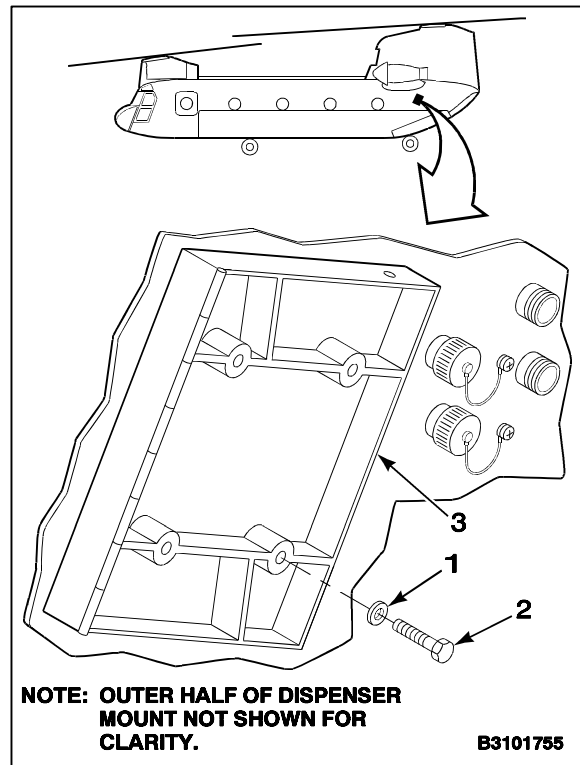
**FOLLOW-ON MAINTENANCE:**

None

END OF TASK

## INITIAL SETUP

**Applicable Configurations:**

All

**Tools:**

Electronic Equipment Tool Kit,  
NSN 5180-00-064-5178  
Torque Wrench, 5-150 Inch-Pounds

**Materials:**

None

**Personnel Required:**

Avionics Mechanic  
Inspector

**Equipment Condition:**

Battery Disconnected (Task 1-39)  
Electrical Power Off  
Hydraulic Power Off  
AN/ALE-47 Safety Switch Pin Installed  
(TM 1-1520-240-10)

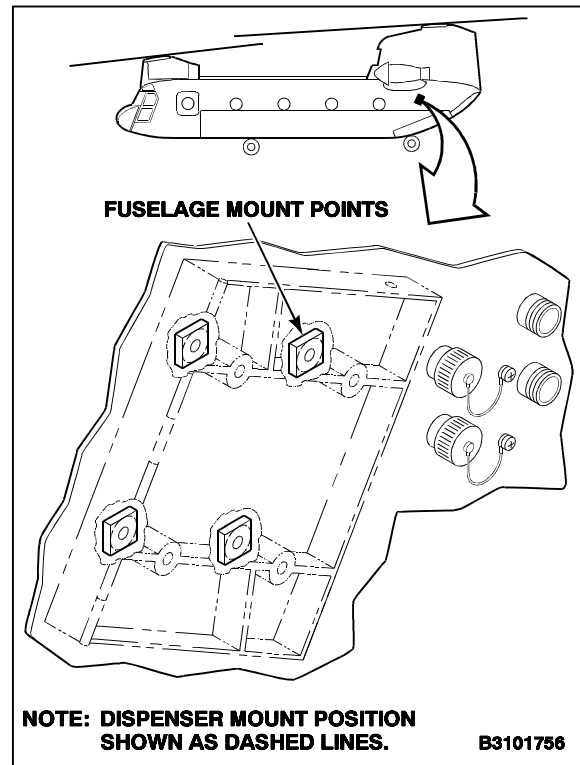



**NOTE**

Procedures to install left and right dispenser assembly mounts are the same.

1. Perform bonding check of electrical components per Task 16-59.28.
2. Install four bolts (2) and washers (1) to secure dispenser assembly mount (3) to fuselage.



An over-torque of bolts can cause a failure in retaining the dispenser assembly during flight and flare dispensing.

3. Torque bolts (2) from **50-70 inch-pounds**.

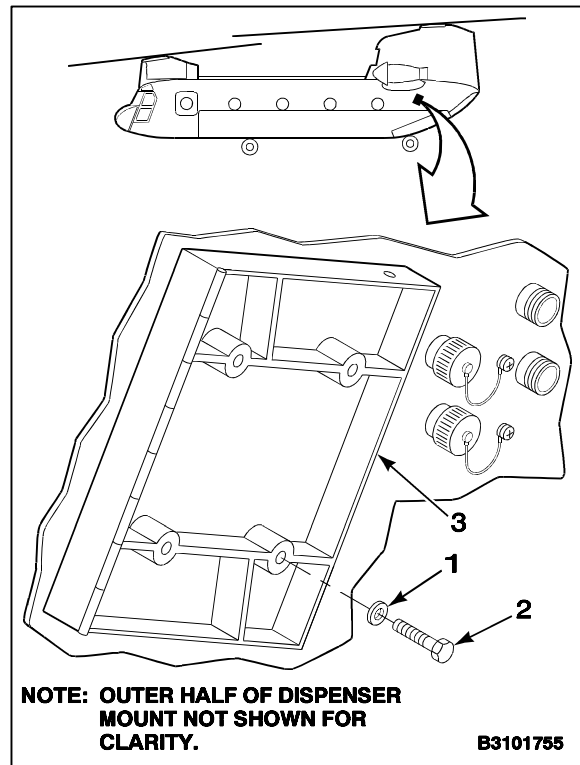
**INSPECT**

**NOTE: OUTER HALF OF DISPENSER MOUNT NOT SHOWN FOR CLARITY.**

B3101755

**FOLLOW-ON MAINTENANCE:**

None

END OF TASK

INITIAL SETUP

**Applicable Configurations:**

All

**Tools:**

Electronic Equipment Tool Kit,  
NSN 5180-00-064-5178

**Materials:**

Paper Tag (E264)

**Personnel Required:**

Avionics Mechanic

**Equipment Condition:**

- Battery Disconnected (Task 1-39)
- Electrical Power Off
- Hydraulic Power Off
- AN/ALE-47 Safety Switch Pin Installed  
(TM 1-1520-240-10)
- Cabin Acoustic Blanket Removed (Task 2-208)

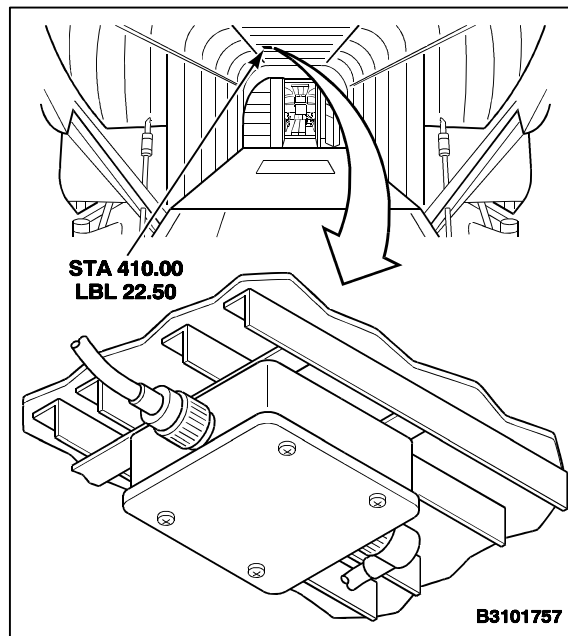

1. Disconnect, tag and cap two electrical connectors (4 and 12) from junction box receptacles (3 and 11).
2. Remove four screws (7) and eight washers (6) securing cover (5) to junction box (2).



Support junction box while removing screws. Failure to comply may result in damage to junction box.

3. Remove four screws (9) and washers (10) securing junction box (2) to mount bracket (1).
4. Remove junction box (2).

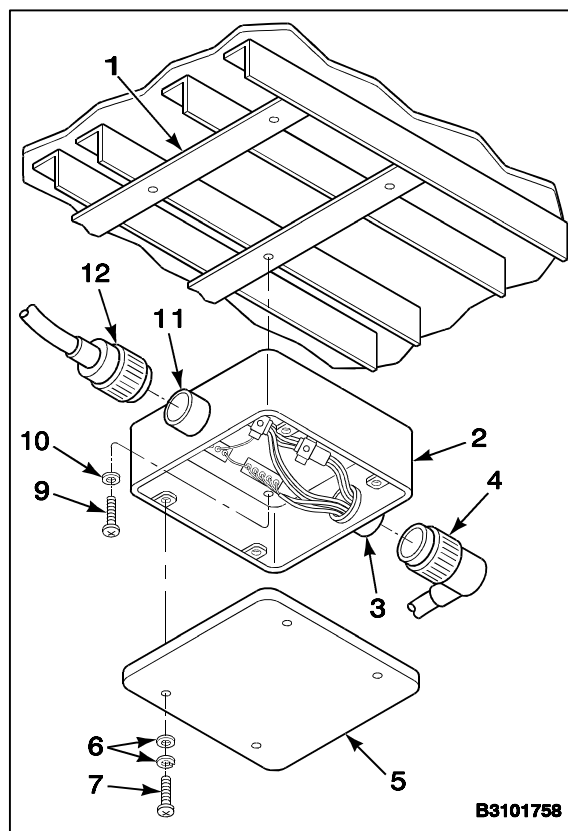

**FOLLOW-ON MAINTENANCE:**

None

END OF TASK

INITIAL SETUP

**Applicable Configurations:**

All

**Tools:**

Electronic Equipment Tool Kit,  
NSN 5180-00-064-5178

**Materials:**

None

**Personnel Required:**

Avionics Mechanic  
Inspector

**Equipment Condition:**

Battery Disconnected (Task 1-39)  
Electrical Power Off  
Hydraulic Power Off  
AN/ALE-47 Safety Switch Pin Installed  
(TM 1-1520-240-10)

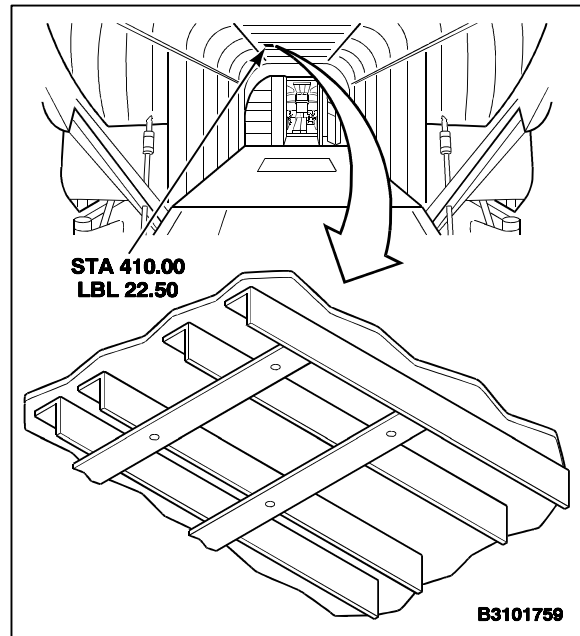

1. Position junction box (2) onto mount bracket (1) and secure with four screws (9) and washers (10).
2. Position cover (5) onto junction box (2) and secure with four screws (7) and eight washers (6).
3. Perform bonding check of electrical components per Task 16-59.28.
4. Remove caps and connect two electrical connectors (4 and 12) to junction box receptacles (3 and 11). Remove tags.

**INSPECT**

**FOLLOW-ON MAINTENANCE:**

Perform operational check of countermeasures dispenser system (TM 1-1520-240-10).  
Install cabin acoustic blanket (Task 2-210).

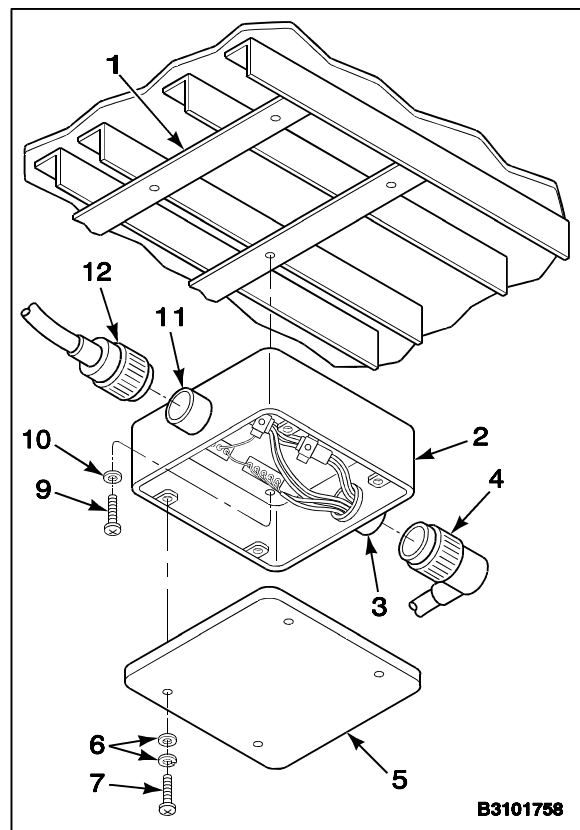

END OF TASK

INITIAL SETUP

**Applicable Configurations:**

All

**Tools:**

Electronic Equipment Tool Kit,  
NSN 5180-00-064-5178

**Materials:**

None

**Personnel Required:**

Avionics Mechanic

**Equipment Condition:**

Battery Disconnected (Task 1-39)  
Electrical Power Off  
Hydraulic Power Off  
AN/ALE-47 Safety Switch Pin Installed  
(TM 1-1520-240-10)

Refer to REMOVE FLARE DISPENSER STATUS PANEL  
(Task 16-51).

**FOLLOW-ON MAINTENANCE:**

None

END OF TASK

16-250.42 Change 1

## INITIAL SETUP

**Applicable Configurations:**

All

**Tools:**Electronic Equipment Tool Kit,  
NSN 5180-00-064-5178**Materials:**

None

**Personnel Required:**

Avionics Mechanic

**Equipment Condition:**Battery Disconnected (Task 1-39)  
Electrical Power Off  
Hydraulic Power Off  
AN/ALE-47 Safety Switch Pin Installed  
(TM 1-1520-240-10)Refer to DISASSEMBLE FLARE DISPENSER STATUS  
PANEL (Task 16-52).**FOLLOW-ON MAINTENANCE:**

None

END OF TASK

INITIAL SETUP

**Applicable Configurations:**

All

**Tools:**

Electronic Equipment Tool Kit,  
NSN 5180-00-064-5178

**Materials:**

None

**Personnel Required:**

Avionics Mechanic

**Equipment Condition:**

Battery Disconnected (Task 1-39)  
Electrical Power Off  
Hydraulic Power Off  
AN/ALE-47 Safety Switch Pin Installed  
(TM 1-1520-240-10)

Refer to ASSEMBLE FLARE DISPENSER STATUS  
PANEL (Task 16-53).

**FOLLOW-ON MAINTENANCE:**

None

END OF TASK

16-250.44 Change 1

**16-59.25 INSTALL LANDING GEAR BYPASS STATUS PANEL****16-59.25**

## INITIAL SETUP

**Applicable Configurations:**

All

**Tools:**Electronic Equipment Tool Kit,  
NSN 5180-00-064-5178**Materials:**

None

**Personnel Required:**

Avionics Mechanic

**Equipment Condition:**Battery Disconnected (Task 1-39)  
Electrical Power Off  
Hydraulic Power Off  
AN/ALE-47 Safety Switch Pin Installed  
(TM 1-1520-240-10)

1. Perform bonding check of electrical components per Task 16-59.28.
2. Refer to INSTALL FLARE DISPENSER STATUS PANEL (Task 16-54).

**FOLLOW-ON MAINTENANCE:**

Perform operational check of countermeasures dispenser system (TM 55-1520-240-T).

END OF TASK

## INITIAL SETUP

**Applicable Configurations:**

All

**Tools:**Electronic Equipment Tool Kit,  
NSN 5180-00-064-5178**Materials:**

Paper Tag (E264)

**Personnel Required:**

Avionics Mechanic

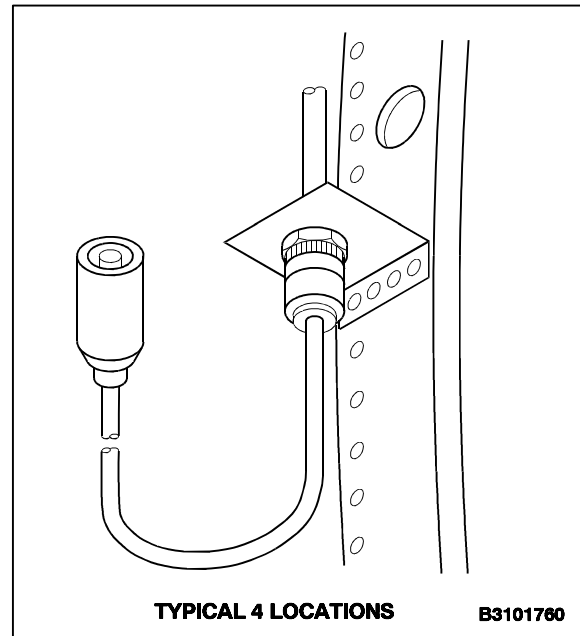
**Equipment Condition:**Battery Disconnected (Task 1-39)  
Electrical Power Off  
Hydraulic Power Off  
AN/ALE-47 Safety Switch Pin Installed  
(TM 1-1520-240-10)**NOTE**Procedures to remove all four crew  
dispense switches are the same.

1. Disconnect, tag and cap electrical connector (3) from receptacle (2).
2. Remove crew dispense switch (1).

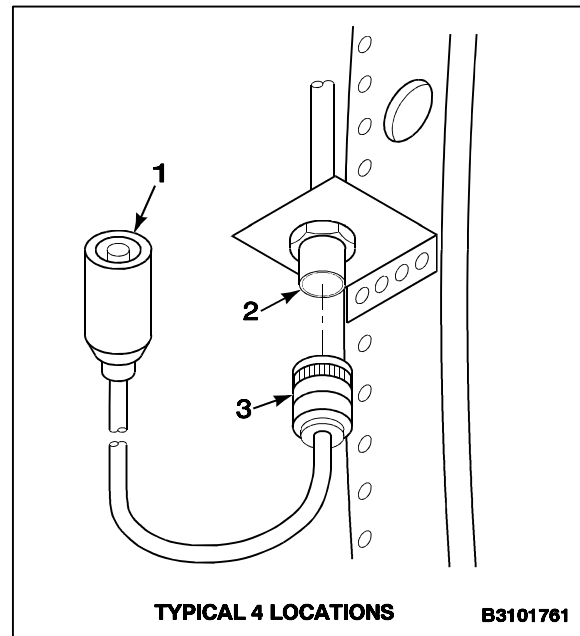
**FOLLOW-ON MAINTENANCE:**

None

END OF TASK

16-250.46 Change 1



## INITIAL SETUP

**Applicable Configurations:**

All

**Tools:**Electronic Equipment Tool Kit,  
NSN 5180-00-064-5178**Materials:**

None

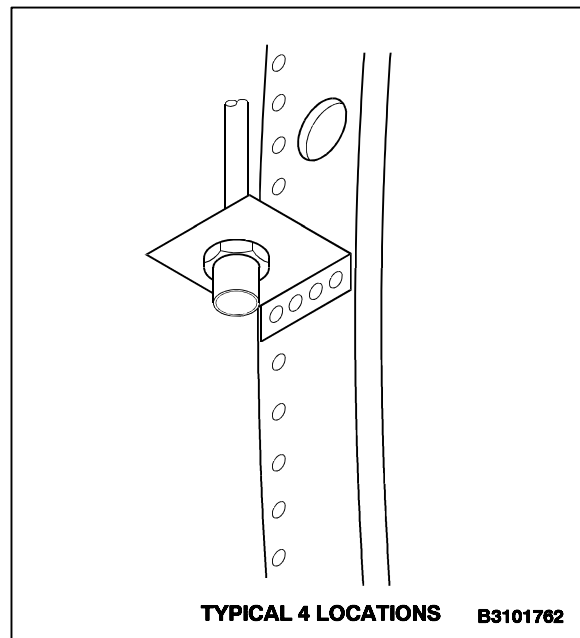
**Personnel Required:**Avionics Mechanic  
Inspector**Equipment Condition:**Battery Disconnected (Task 1-39)  
Electrical Power Off  
Hydraulic Power Off  
AN/ALE-47 Safety Switch Pin Installed  
(TM 1-1520-240-10)**NOTE**Procedures to install all four crew  
dispense switches are the same.

1. Remove cap and connect crew dispense switch (1) electrical connector (3) to receptacle (2). Remove tag.
2. Perform bonding check of electrical components per Task 16-59.28.

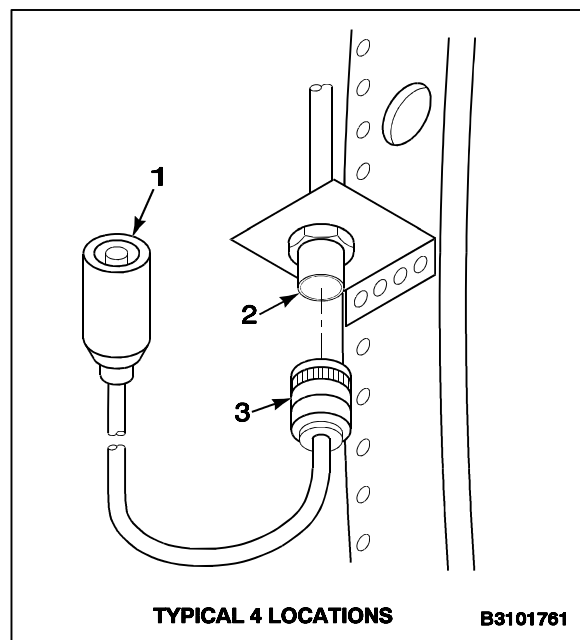
**INSPECT****FOLLOW-ON MAINTENANCE:**Perform operational check of countermeasures  
dispenser system (TM 55-1520-240-T).

END OF TASK

## INITIAL SETUP

**Applicable Configurations:**

All

**Tools:**

Electronic Equipment Tool Kit,  
NSN 5180-00-064-5178  
Biddle Ohmmeter (T7) or Equivalent

**Materials:**

Cloths (E135)  
Gloves (E184.1)  
Naphtha (E293)  
Goggles (E473)

**Personnel Required:**

Avionics Mechanic  
Aircraft Electrician Inspector  
Inspector

**Equipment Condition:**

As Required

**WARNING**

Aliphatic naphtha (E293) is combustible and toxic. It can irritate skin and cause burns. Use only with adequate ventilation, away from open flame. In case of contact, immediately flush skin or eyes with water for at least **15 minutes**. Get medical attention for eyes.

1. Clean bonding and grounding surface thoroughly before installing components. Use naphtha (E293) and cloths (E135). Wear gloves (E184.1) and goggles (E473).
2. Install components and bonding straps, (if applicable) per installation procedures of components. Do not install connectors. Perform bonding check. Use biddle ohmmeter (T7) or equivalent to test the resistance between the cleaned surfaces and aircraft ground. Resistance shall be **0.0025 ohms** or less.
3. Refinish exposed surfaces in accordance with applicable corrosion control directives.

**INSPECT****FOLLOW-ON MAINTENANCE:**

None

END OF TASK

16-250.48 Change 1

INITIAL SETUP

**Applicable Configurations:**

All

**Tools:**

Electronic Equipment Tool Kit,  
NSN 5180-00-064-5178  
Universal Memory Loader Verifier (UMLV),  
NSN 1680-01-504-6082

**Materials:**

None

**Personnel Required:**

Avionics Mechanic (2)

**References:**

D000 2970 Rev D  
OM 3647-40-1

**Equipment Condition:**

Aircraft Power On (As Required)  
Battery Connected  
Hydraulic Power Off  
LDG GR SW Bypass Switch in Normal  
(TM 1-1520-240-10)  
ALQ-156 MWS is Off

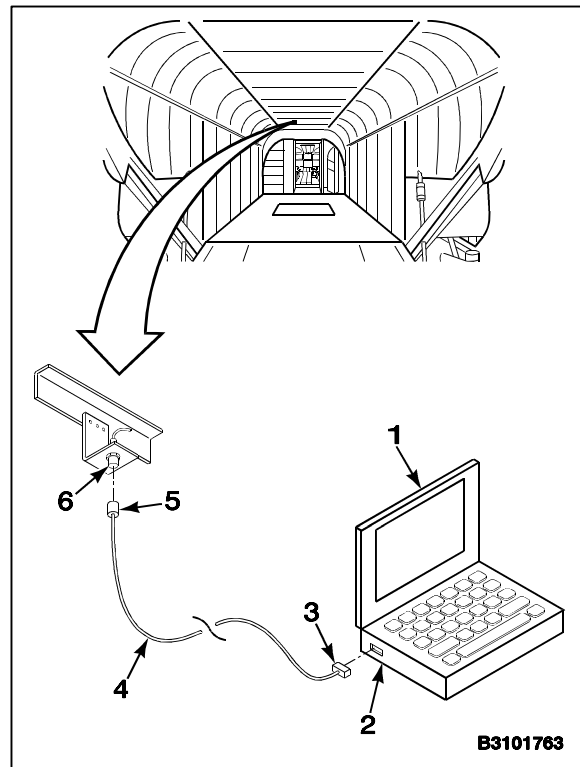

Load Operational Flight Program (OFF) or Mission Data File (MDF).

**NOTE**

Before starting MLV and loading OFF or MDF, check that the proper OFF and MDF software version numbers has been verified with the unit's MDF Documentation or unit Aircraft Survivability Equipment (ASE) officer.

1. Unpack and set up MLV (1) on flat work surface near MLV interface port in cabin.
2. Connect MLV interface cable (4) connector (3) to the MLV 1553 BUS A port (2) and connector (5) to the MLV interface port (6).
3. Apply power to aircraft.
4. Verify ALE-47 DCDU circuit breaker (CB) (8) on No. 1 EAPS PDP (7) is in.
5. Pull out ALE-47 SQUIB PWR NO. 1 (9) and NO. 2 (10) CBs on No. 1 EAPS PDP (7).

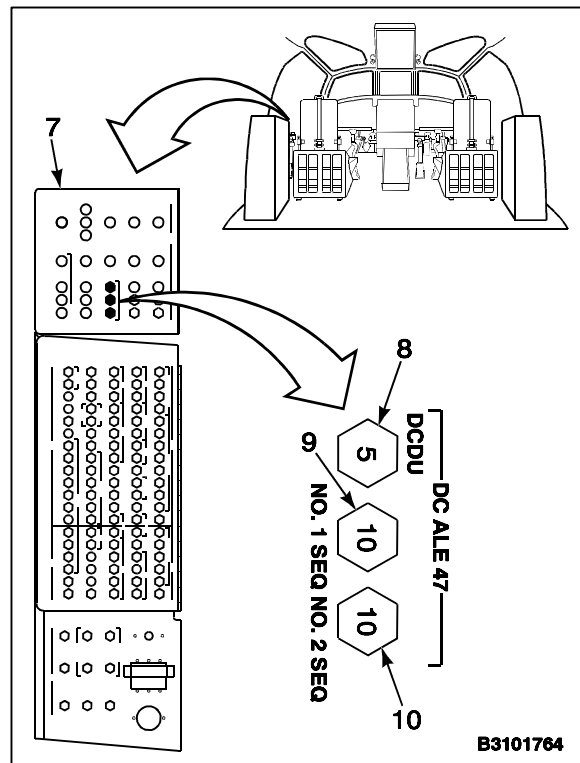

6. Verify MODE (13) and JETTISON (14) switches on DCDU (11) are off.
7. Set DCDU MODE switch (13) to STBY.
8. If required, press the following DCDU INHIBIT (12) pushbutton switches so that their respective LEDs are not illuminated: MWS, JMR, RWR, O1, O2, CH, and FL.

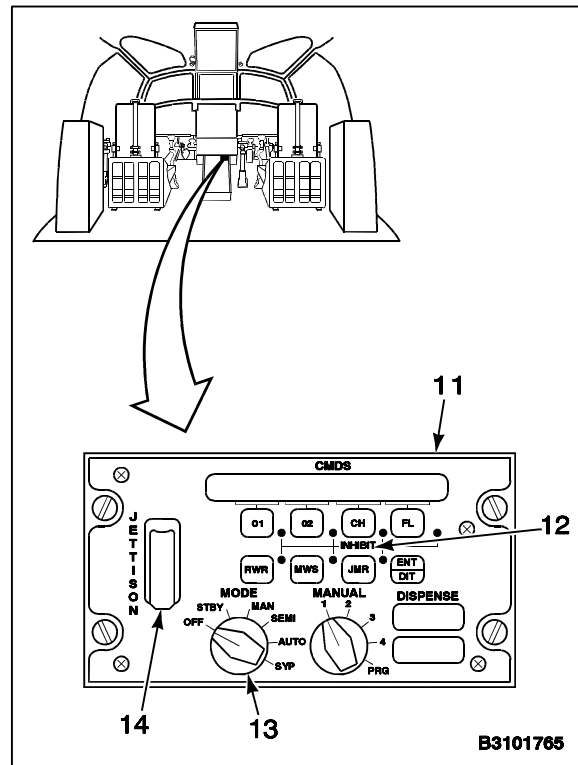

9. Power up MLV by pressing and holding POWER switch on keyboard briefly. The MLV LED indicator illuminates light green or yellow green and changes to yellow when in power save mode. If LED does not light, press POWER switch again. Observe MLV screen to verify that system boots through MS-DOS and initiates the Windows software. After boot-up, the MLV opening screen (Windows Desktop) is displayed.

**NOTE**

OPF loading will overwrite MDF memory. If there is no OPF or incorrect OPF is loaded on the Programmer, the OPF must be loaded first before loading the MDF.

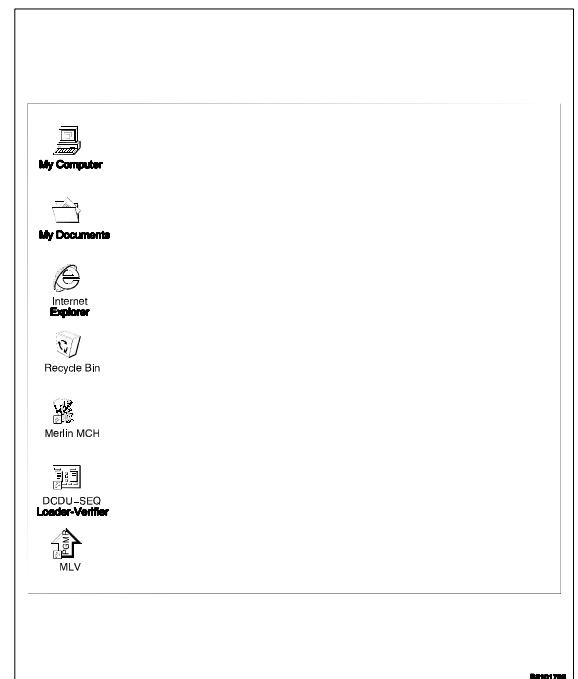

10. Double click on the **PROG MLV** icon. A self-test screen (showing ALE-47 system LRUs) will be displayed momentarily. The MLV screen will appear next.

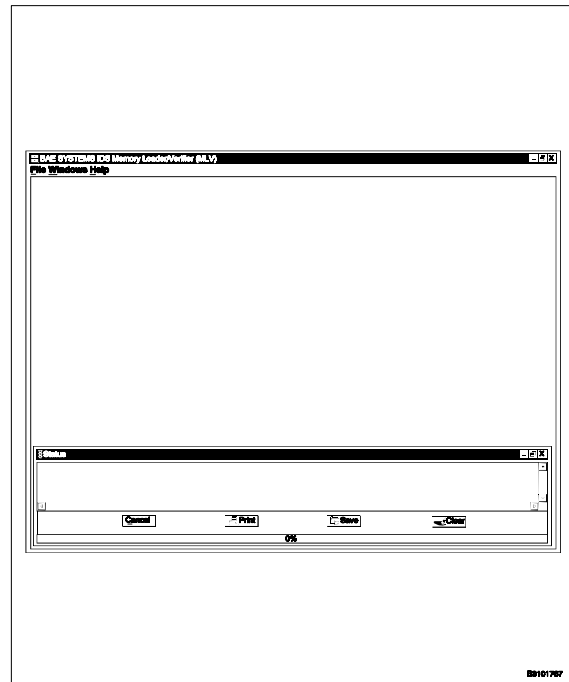

11. On the menu bar at the top screen, select **File**, then **Open**. A window will appear listing various MDF files.

**NOTE**

In the Windows **Open** Dialog Box, it may be necessary to select file location from the **Look in:** pull-down menu and select file type from **Files of type:** pull-down menu.

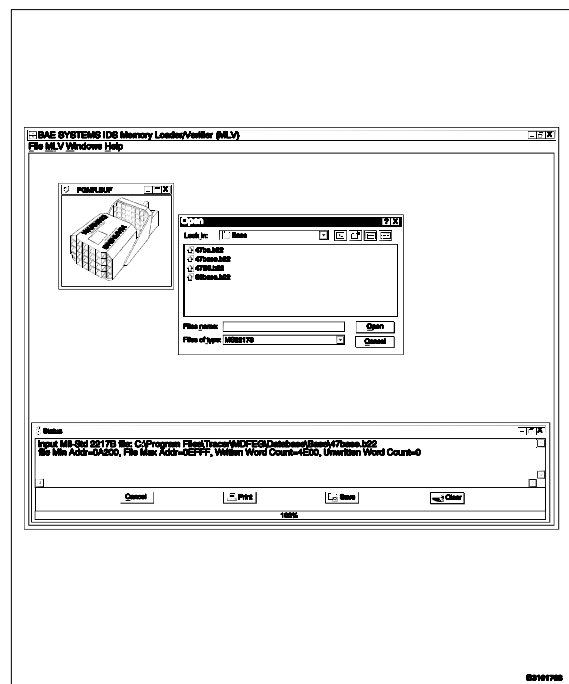

- Select the OFP or MDF file to be uploaded, then select **Open**. The file will begin loading to the MLV Buffer.

**NOTE**

The load bar at the bottom of the screen will show the progress of the upload.

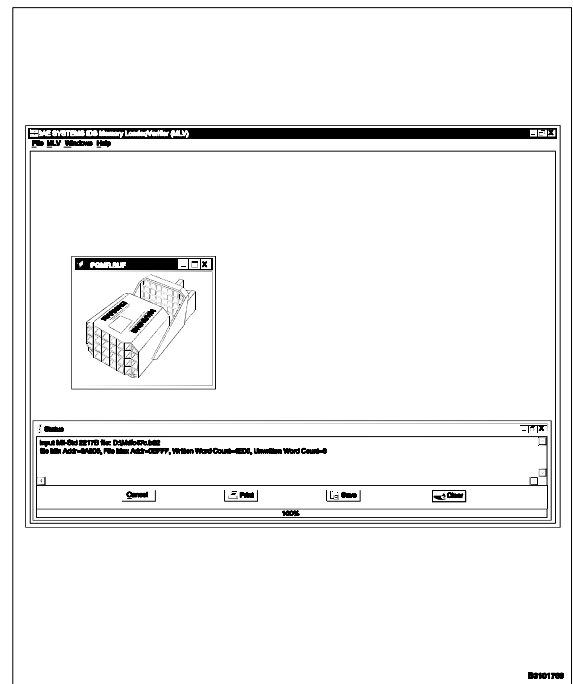

- After upload is complete, select **MLV** from menu bar, then **Select Protocol**.

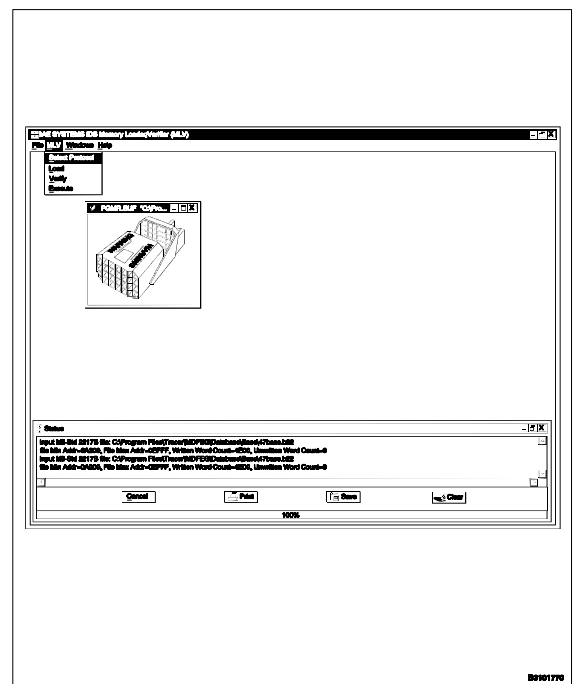

- The **Select Download Type** dialog box will appear. Select the required protocol file to be loaded. Select the **Select** button.

**NOTE**

The menu bar will change to **MLV (MS2217B MLV)**.

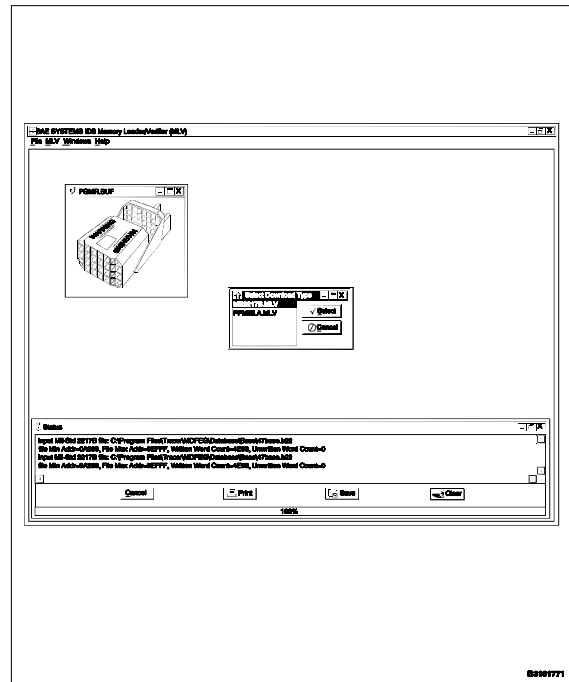

- On menu bar, click **MLV (MS2217B MLV)**, then select **Load**. System will load OFP or MDF to the programmer. Bottom of screen bar will show the status of progress.

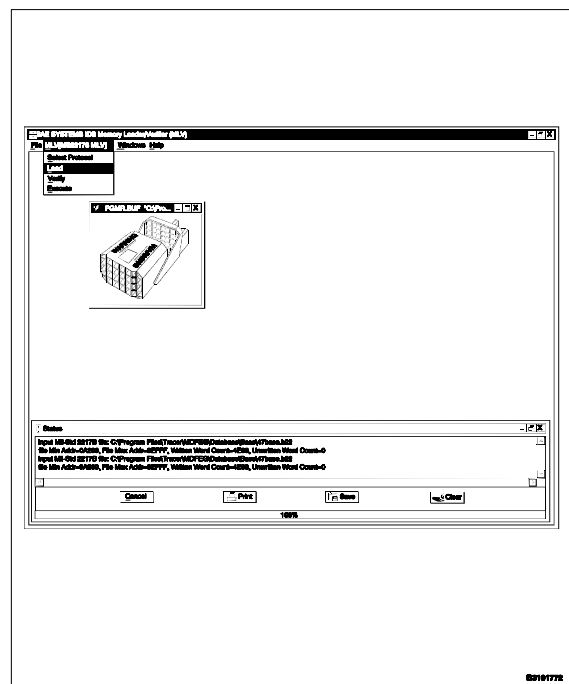

16. After upload is complete, a dialog box will appear: **Load successful. Verify?** Select **Yes**.

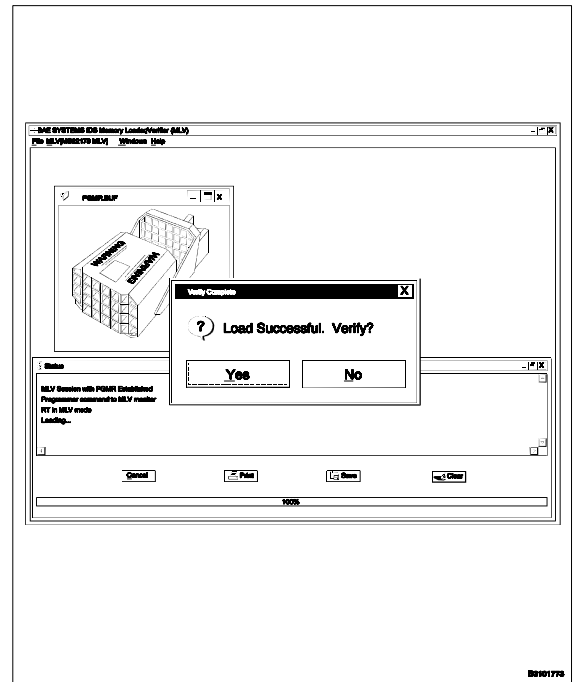

17. The verification complete screen will appear. Select **OK**.
18. On menu bar, select **File**, then select **Exit**.
19. If OFP loading has been completed, repeat steps 10 thru 18. If MDF loading has been completed, continue to next step.

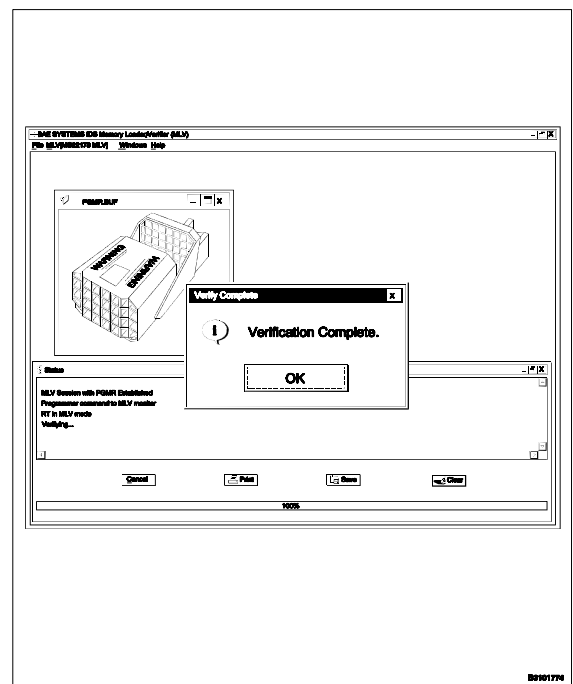



- 20. Reset system by turning DCDU mode switch to OFF and to STBY. Verify DCDU displays **OPF1120** and **MDFC47C** during Power-Up BIT (P-BIT).

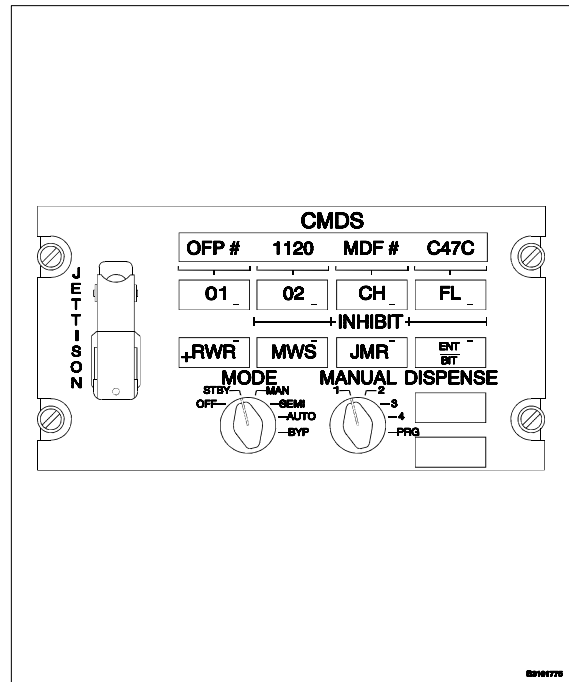

- 21. Verify DCDU displays payload inventory.

**NOTE**

Inventory displayed on the DCDU will vary based on the number of CDT's installed in the dispensers:

	O1	O2	CH	FL
1 CDT installed:	10	10		10
2 CDTs installed:	20	20		20
3 CDTs installed:	30	30		30
4 CDTs installed:	40	40		40

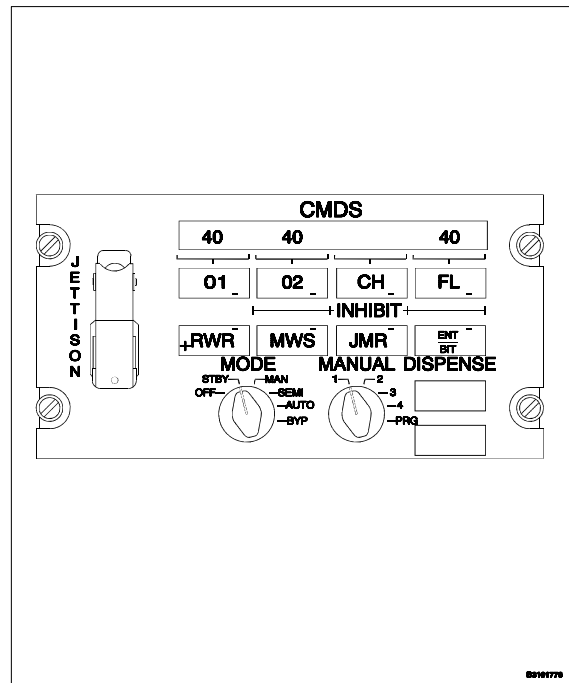

22. Disconnect interface cable; power down and remove MLV.
23. Set DCDU MODE switch to OFF.
24. Remove power from aircraft.

***FOLLOW-ON MAINTENANCE:***

Perform operational check of AN/ALE-47 CMDS per TM 55-1520-240-T.

END OF TASK

16-250.56 Change 1

INITIAL SETUP

**Applicable Configurations:**

All

**Tools:**

- Electronic Equipment Tool Kit,  
NSN 5180-00-064-5178
- Countermeasures Dispenser Test Set Assembly  
(CDTS)
- Torque Wrench, 5-50 Inch-Pounds

**Materials:**

None

**Personnel Required:**

Avionics Mechanic (2)

**Equipment Condition:**

- Aircraft Power On (As Required)
- Battery Connected
- Hydraulic Power Off

5. Set CDT MODE switch to FIRE TEST position. CDT will perform BIT and display either PASS or FAIL.
6. Set CDT MODE switch to OFF, then install CDT into dispenser being tested. Torque bolts to **40 inch-pounds**.
7. Set CDT MODE switch to S. V. Wait for CDT display to read PASS.
8. If FAIL message followed by failed pin numbers is displayed, stray voltage exists on the CMDS dispense fire lines indicated and must be corrected before payload modules can be installed. Shut down aircraft power. Starting at the dispenser pins, use multimeter to locate the source of the stray voltage. If CMDS is not the source of the stray voltage, the aircraft wiring must be checked to locate and repair the stray voltage condition. After repairs, repeat this procedure and retest until all lines pass.
9. Set CDT MODE switch to OFF.
10. Set CDT encoder pins as follows:



If CMDS is loaded with expendables, they must be downloaded prior to test. Ensure safety pin is installed in safety switch and safety pin flag is prominently displayed. Failure to comply could result in death or injury to personnel or damage to equipment.

**NOTE**

The settings of the sequencer switches are critical for proper CMDS operation.

1. Ensure sequencer switches are set as follows:  
LH (No. 1) Sequencer — 1A  
RH (No. 2) Sequencer — 2A
2. Apply **+28 vdc** to CMDS.
3. Set DCDU MODE and JETTISON switches to OFF.
4. Remove all payload modules from CMDS dispensers per Task 16-59.12.

DISP. NO.	AIRCRAFT LOCATION	MAG ID	ENCODER PIN LOCATION			
			S2	S3	S4	S5
1	LH LOWER	1	X	O	O	O
2	RH LOWER	8	O	O	O	X
3	LH UPPER	1	X	O	O	O
4	RH UPPER	8	O	O	O	O

X = Coding Pin Installed  
O = Coding Pin Not Installed

11. Set DCDU MODE switch to STBY.
12. Once expendable inventory is displayed on DCDU, press and release DCDU ENT/BIT switch to initiate BIT. Verify that no failure conditions are reported via DCDU display. When BIT is completed, check that expendable inventory is displayed on DCDU.
13. Set CDT MODE switch to S.V. Wait for CDT display to read PASS.

14. If FAIL message followed by failed pin numbers is displayed, stray voltage exists on the CMDS dispense fire lines indicated and must be corrected before payload modules can be installed. Shut down aircraft power. Starting at the dispenser pins, use multimeter to locate the source of the stray voltage. If CMDS is not the source of the stray voltage, aircraft wiring must be checked to locate and repair the stray voltage condition. After repairs, repeat this procedure and retest until all lines pass.
15. Set CDTS MODE switch to OFF.
16. Set DCDU MODE switch to OFF.
17. Repeat test for untested dispensers.
18. Proceed with loading payload modules per Task 16-59.13.

***FOLLOW-ON MAINTENANCE:***

None

END OF TASK

**16-250.58**      **Change 1**

**SECTION VII**  
**LITTER PROVISIONS DESCRIPTION AND OPERATION**

There are provisions in the cabin for the installation of 24 litters. The provisions consist of 12 removable litter stanchions and 12 litter straps. Each stanchion and each strap has four litter support brackets attached to it. This permits the installation of up to four tiers of litters. Provisions are made for stowage of the litter poles at sta 120 on the left side of the cabin. Provisions are made for the stowage of litter straps in 12 containers above the cabin ceiling.

Each stanchion rests on the floor between two stud spacers. The upper end of the stanchion is attached to fittings mounted on the support tube of the troop seat backrest. The center of the pole is connected to the troop seat support rail. Each litter strap is attached to an adapter on the floor. A hook at the top of the strap is attached to a horizontal bolt installed in the cabin ceiling.

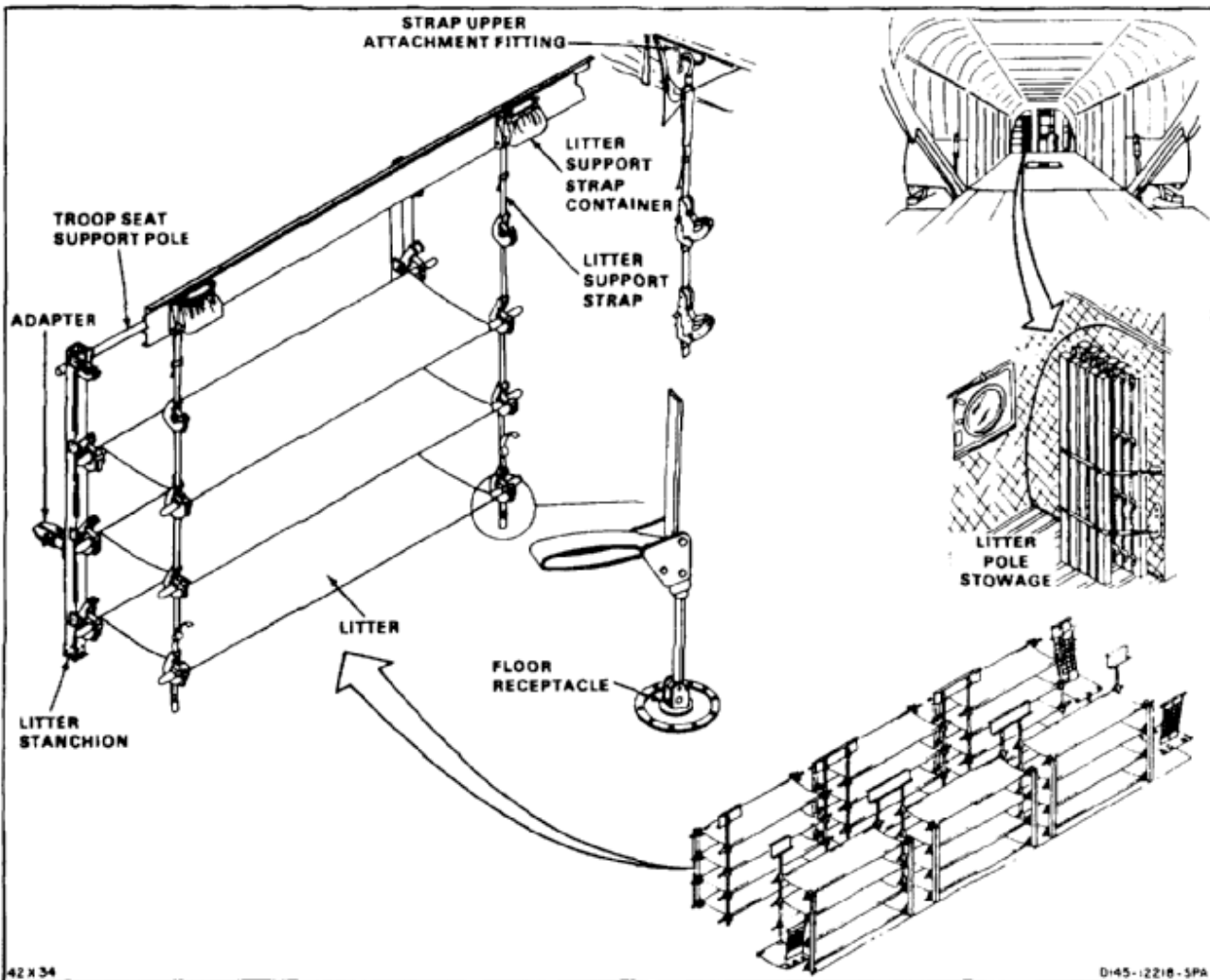

END OF TASK

**SECTION VIII**  
**LITTER PROVISIONS**

INITIAL SETUP

**Applicable Configurations:**

All

**Tools:**

None

**Materials:**

None

**Personnel Required:**

Medium Helicopter Repairer

**Equipment Condition:**

Battery Disconnected (Task 1-39)  
Electrical Power Off

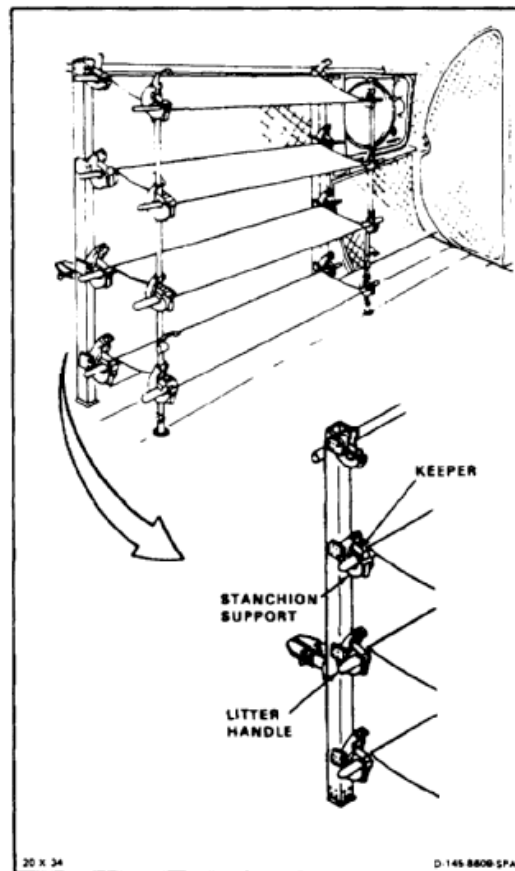

1. Lift four keepers (1) and remove litter handles (2) from stanchion supports (3)
2. Remove quick-disconnect pin (4).

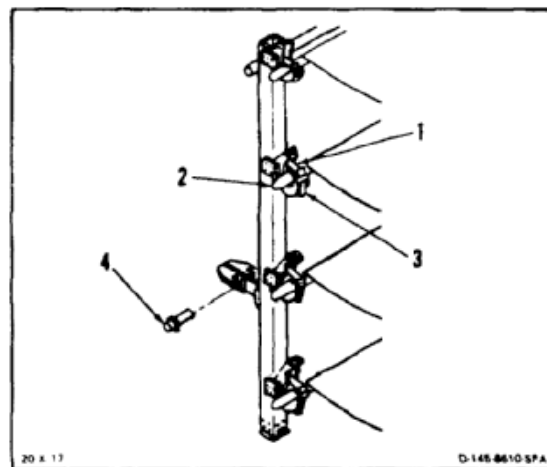



**16-61 REMOVE LITTER STANCHION (Continued)**

16-61

3. Pull knob (5) to release stop (6).
4. Lift litter stanchion (7) until two fittings (8) on tube (9) align with two slotted holes in stanchion.
5. Remove stanchion (7).

***FOLLOW-ON MAINTENANCE:***

None

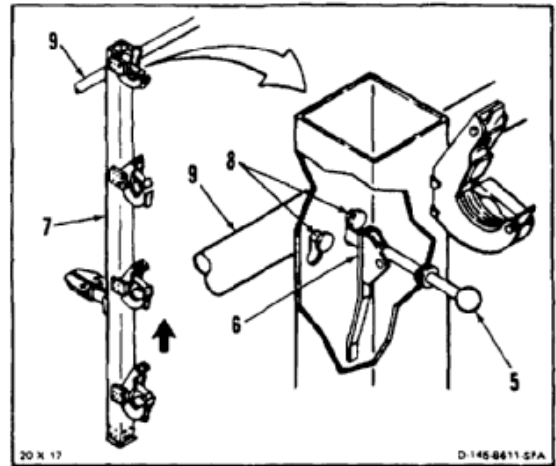

END OF TASK

INITIAL SETUP

**Applicable Configurations:**

All

**Tools:**

None

**Materials:**

None

**Personnel Required:**

Medium Helicopter Repairer

**References:**

TM 55-1520-240-23P

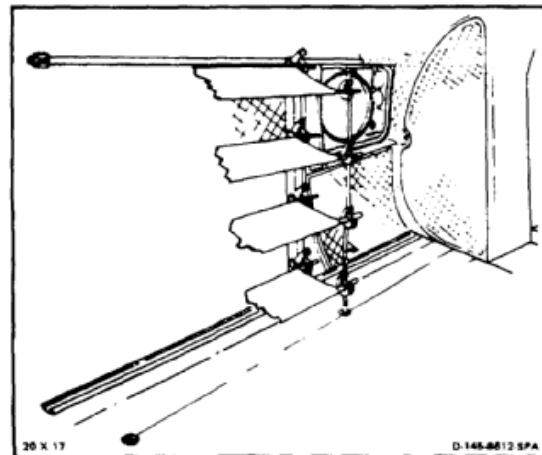

1. Position stanchion (1), with bottom attachment (2) seated between two studs (3) in floor channel (4).

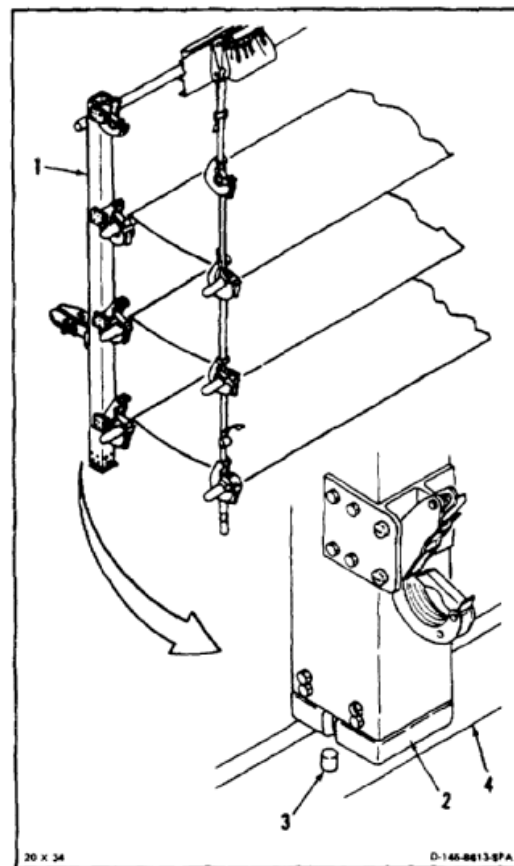

**16-62 INSTALL LITTER STANCHION (Continued)**

16-62

2. Align two slotted holes in stanchion (1) with two fittings (5) on tube (6).
3. Push stanchion (1) against tube (6) until two slotted holes fit over two fittings (5).
4. Push down on stanchion (1) until stop (7) engages one fitting (5).

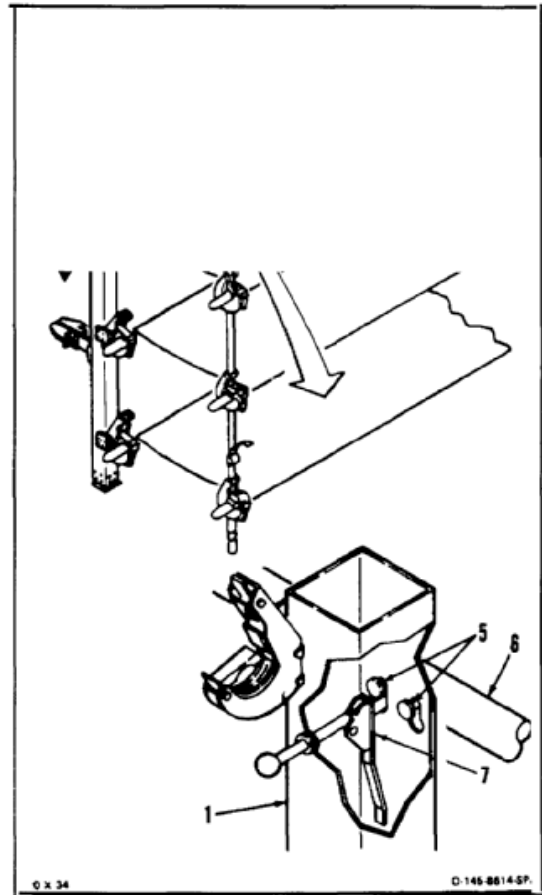

5. Install quick-disconnect pin (8).
6. Lift four keepers (9) and install four litter handles (10) in stanchion supports (11).

**FOLLOW-ON MAINTENANCE:**

None

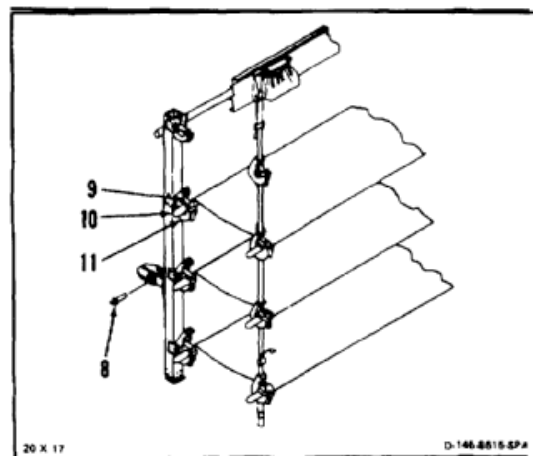

END OF TASK

16-257

## INITIAL SETUP

**Applicable Configurations:**

All

**Tools:**

Aircraft Mechanic's Tool Kit, NSN 5180-00-323-4692

**Materials:**

None

**Personnel Required:**

Medium Helicopter Repairer

**Equipment Condition:**

Battery Disconnected (Task 1-39)  
Electrical Power Off

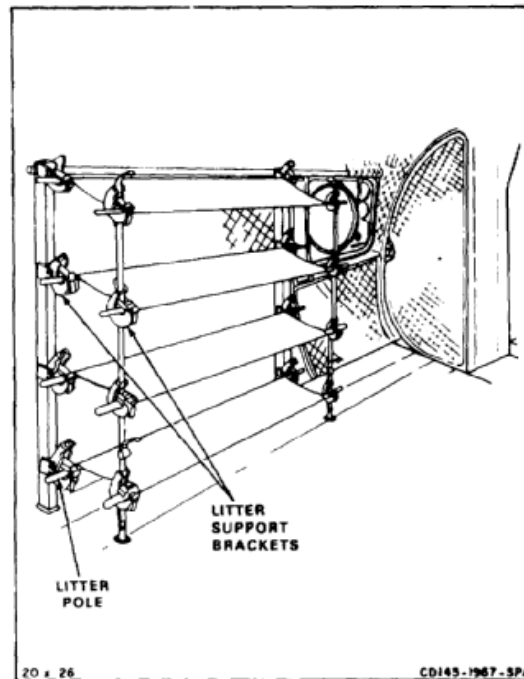
**NOTE**

Procedure can be used for all brackets.

1. Raise keeper (1) and remove litter pole (2).
2. Remove two nuts (3) and washers (4).
3. Remove two bolts (5) and washers (6).
4. Remove litter support bracket (7) from mounting bracket (8).
5. Remove two spacers (9) from litter support bracket (7).

**FOLLOW-ON MAINTENANCE:**

None

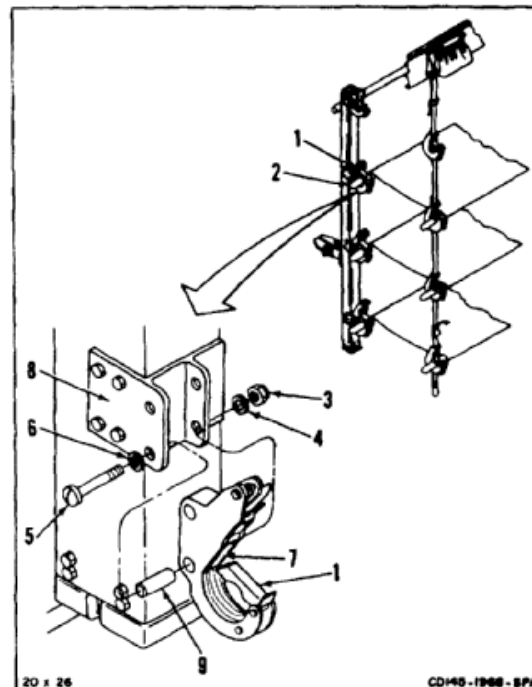

END OF TASK

16-258

**16-64 INSTALL LITTER SUPPORT BRACKET****16-64****INITIAL SETUP****Applicable Configurations:**

All

**Tools:**

Aircraft Mechanic's Tool Kit, NSN 51 80-00-323-4692

**Materials:**

None

**Personnel Required:**

Medium Helicopter Repairer

**References:**

TM 55-1520-240-23P

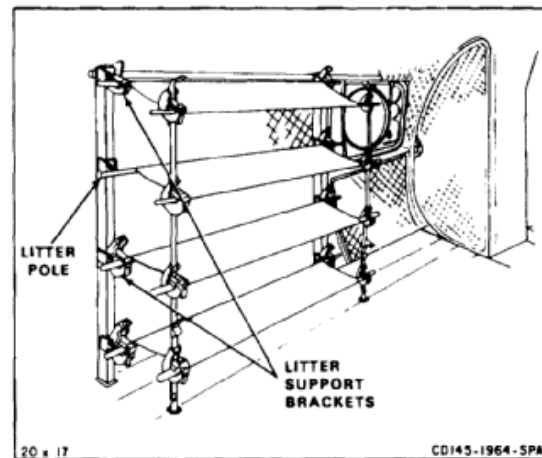
**NOTE**

Procedure can be used for all brackets.

1. Install two spacers (1) in litter support bracket (2).
2. Position support bracket (2) in mounting bracket (3) with keeper (4) facing up.
3. Install two bolts (5) and washers (6).
4. Install two washers (7) and nuts (8).
5. Raise keeper (4) up and install litter pole (9).

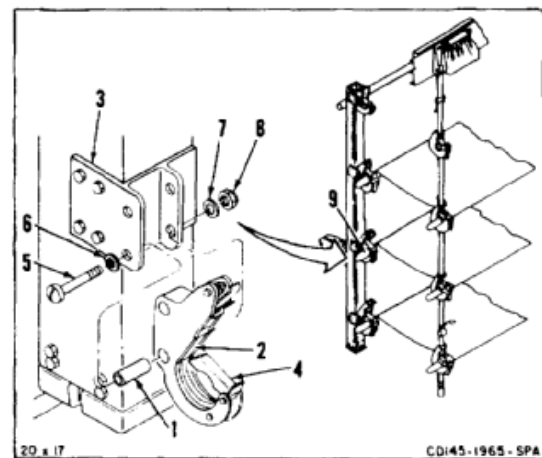
**FOLLOW-ON MAINTENANCE:**

None

END OF TASK

INITIAL SETUP

**Applicable Configurations:**

All

**Tools:**

None

**Materials:**

None

**Personnel Required:**

Medium Helicopter Repairer

**Equipment Condition:**

Battery Disconnected (Task 1-39)  
Electrical Power Off

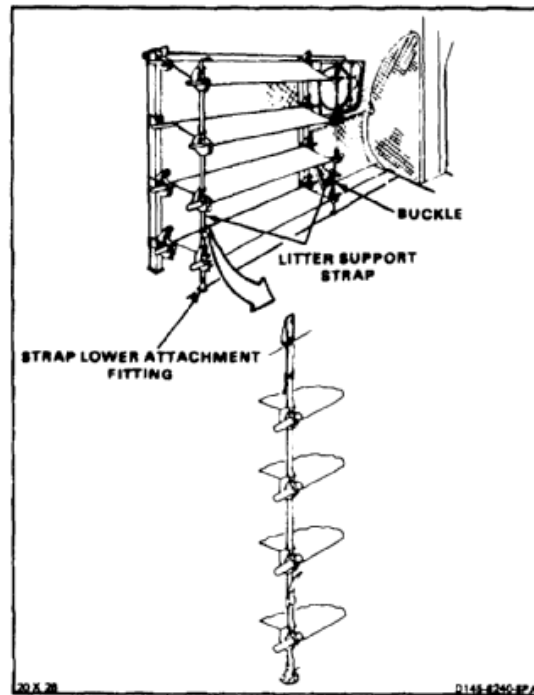

1. Release buckle (1) on litter support strap (2). Loosen strap.
2. Press inward on spring lever (3) and remove strap lower attachment fitting (4) from adapter (5).
3. Disconnect top end of strap (2) from support bracket (6).
4. Lift keeper from strap support and remove four strap supports (7) from litter poles (8). Remove strap (2).

**FOLLOW-ON MAINTENANCE:**

None

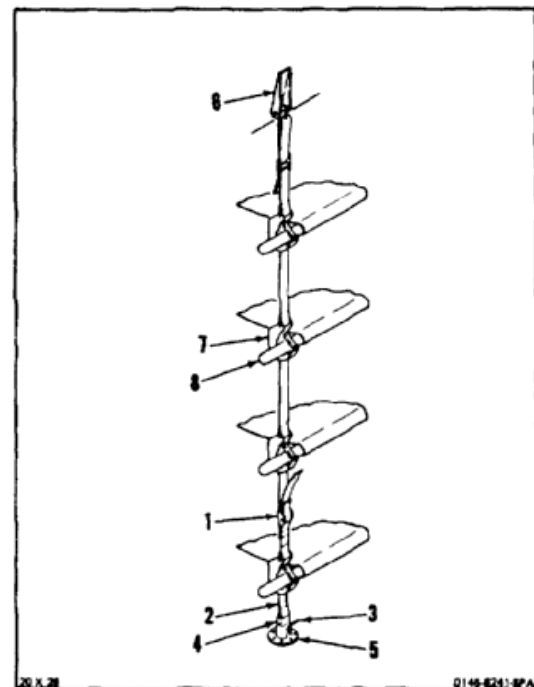

END OF TASK

## INITIAL SETUP

**Applicable Configurations:**

All

**Tools:**

None

**Materials:**

None

**Personnel Required:**

Medium Helicopter Repairer

**References:**

TM 55-1520-240-23P

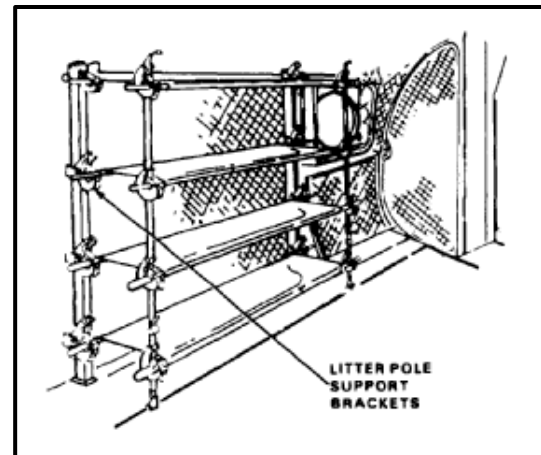

1. Connect strap (1) supports (2) inboard, to support bracket (3).
2. Adjust strap (1) so that strap supports (2) are same height as corresponding supports (4) on litter pole (5).

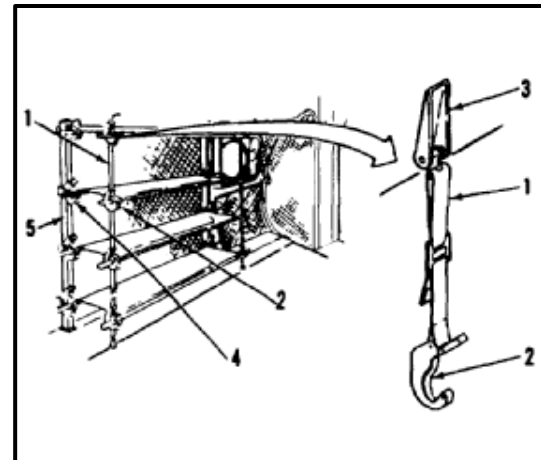

3. Release locking handle (6) and lift locking bar (7). Install litter handles (8) in strap supports (2).
4. Insert locking bar (7) into slot in locking handle (6). Lift handle to lock position.
5. Position lower attachment fitting (9) on adapter (10). Press inward on spring lever (11) and install fitting.
6. Adjust buckle (12), above lowest support (2) to remove slack in strap (1).

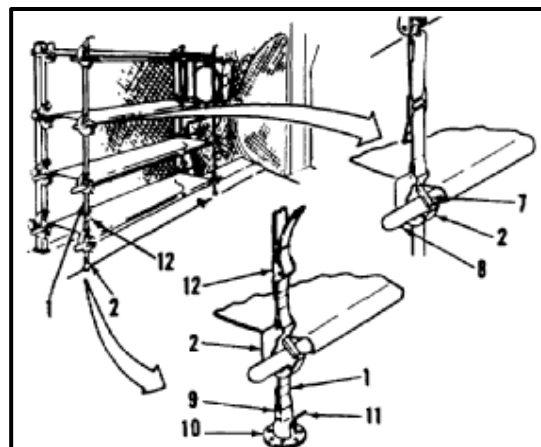
**FOLLOW-ON MAINTENANCE:**

None

END OF TASK





**SECTION IX**  
**SEAT ARMOR PROVISIONS DESCRIPTION**

Helicopters with **7** are furnished with armor for the pilot and copilot seats. The armor for each seat consists of five protective panels, six mounting brackets, a harness reel guide bracket (top bracket), and installation hardware.

bottom, under the cushion. One panel is mounted under the seat back cushion and another is installed at the outboard side of the seat bottom. A shoulder protection panel for the outboard side of the seat back is hinged to allow quick exit through the jettisonable door.

The panels are made of composite material faced with a fiber cover. Two of the panels are installed on the seat

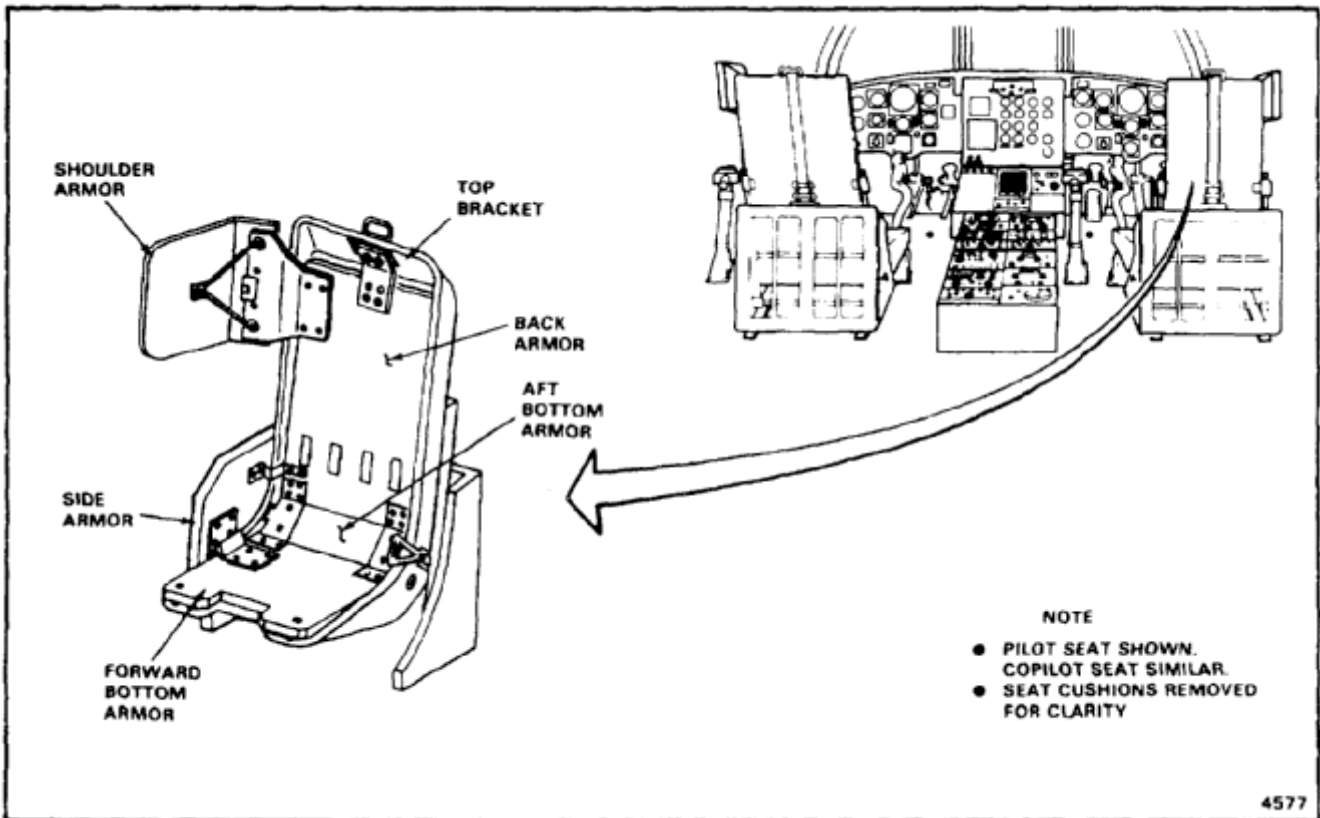

END OF TASK

**SECTION X**  
**SEAT ARMOR PROVISIONS**

INITIAL SETUP

**Applicable Configurations:**

With **7**

**Tools:**

Aircraft Mechanic's Tool Kit, NSN 5180-00-323-4692

**Materials:**

None

**Personnel Required:**

Medium Helicopter Repairer

**References:**

TM 55-1520-240-23P

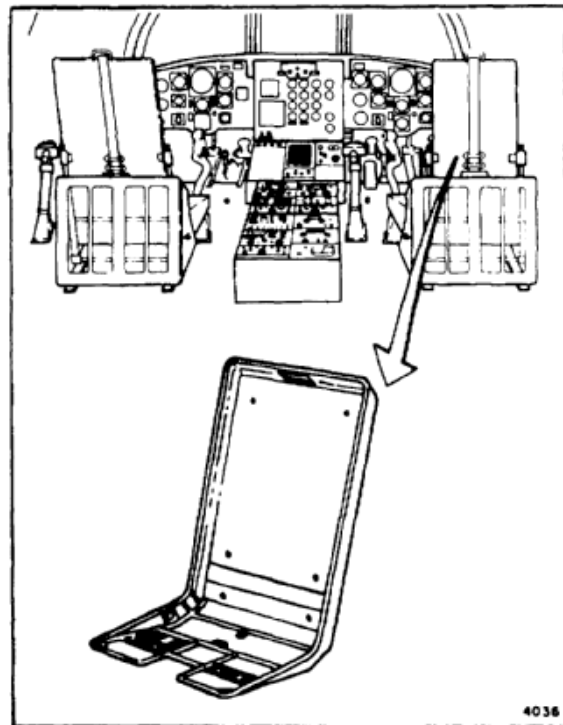

**NOTE**

Procedures are same for installing pilot's or copilot's seat armor. Pilot's seat shown here.

1. Check that spacers (1) are installed in forward corners of seat bucket (2).
2. Install armor panel (3) in seat bucket (2).
3. Install screw (4), washers (5), and nut (6) in each forward corner of panel (3).

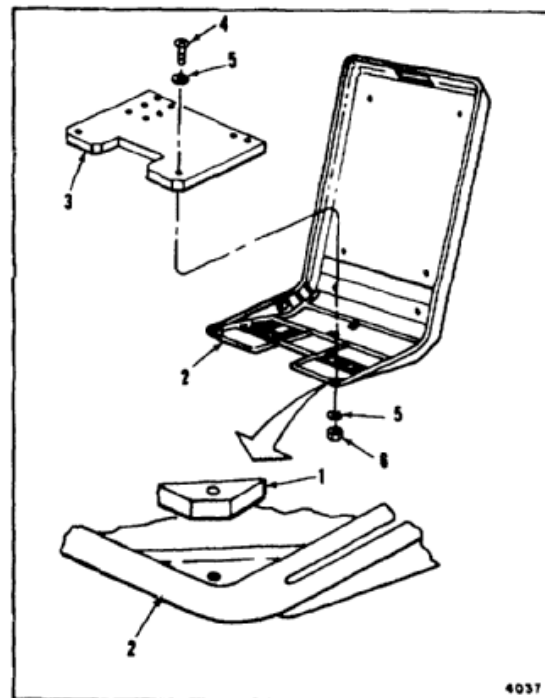

4. Install bracket (7) on seat armor panel (3). Use four screws (8) and washers (9).
5. Install aft bottom armor panel (10).

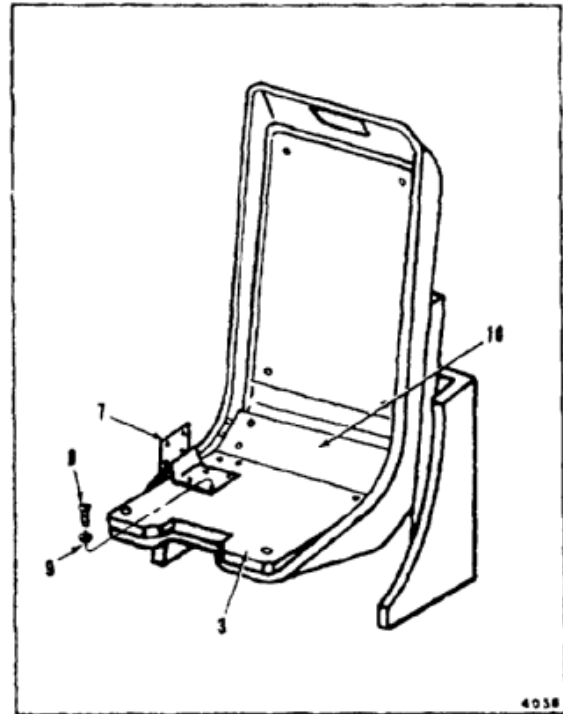

6. Install back armor panel (11), top bracket (12), mounting plate (13), shoulder armor panel (14), and side armor panel (15). (Refer to Task 16-73.)

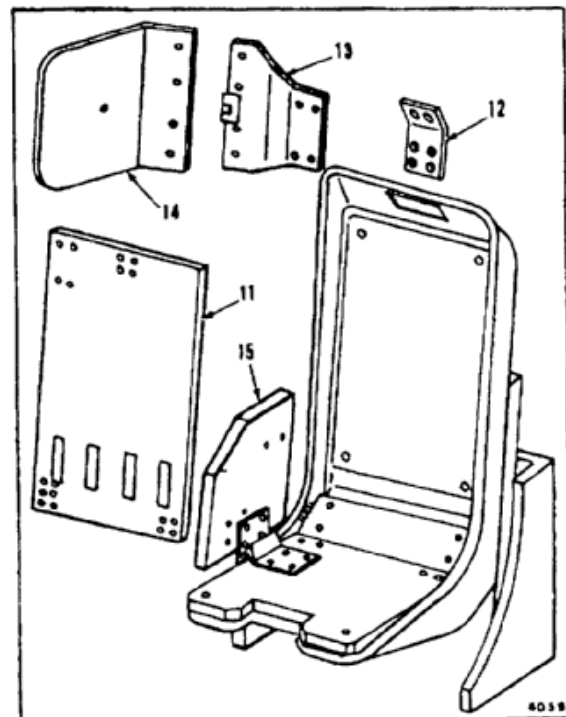

**FOLLOW-ON MAINTENANCE:**

Check seat armor clearance (Task 16-83).

END OF TASK

## INITIAL SETUP

**Applicable Configurations:**With **7****Tools:**

Aircraft Mechanic's Tool Kit, NSN 5180-00-323-4692

**Materials:**

None

**Personnel Required:**

Medium Helicopter Repairer

**Equipment Condition:**

Battery Disconnected (Task 1-39)

Electrical Power Off

Hydraulic Power Off

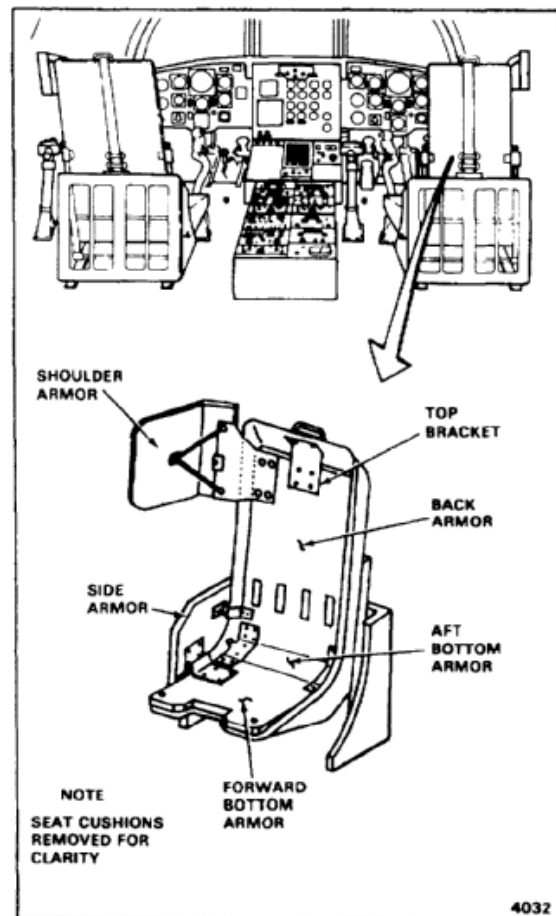
**NOTE**

Procedures are same for removing pilot's or copilot's seat armor. Pilot's seat shown here.

Seat cushions removed for clarity.

1. Remove side armor panel (1), shoulder armor panel and mounting plate (2), top bracket (3), and back armor panel (4). (Refer to Task 16-72.)
2. Remove aft bottom armor panel (5).

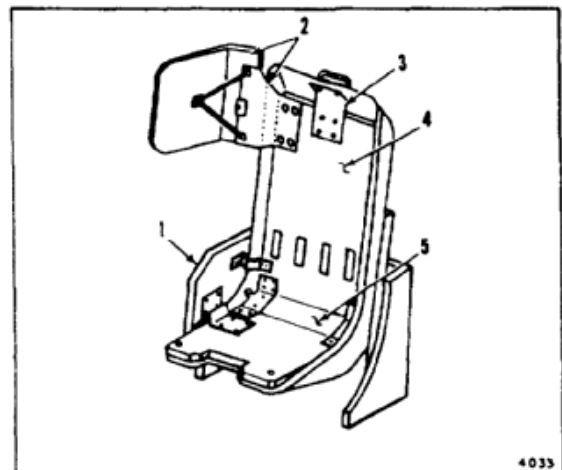

**16-69 REMOVE SEAT ARMOR PANELS (Continued)**

16-69

3. Remove four screws (6) and washers (7).  
Remove bracket (8).

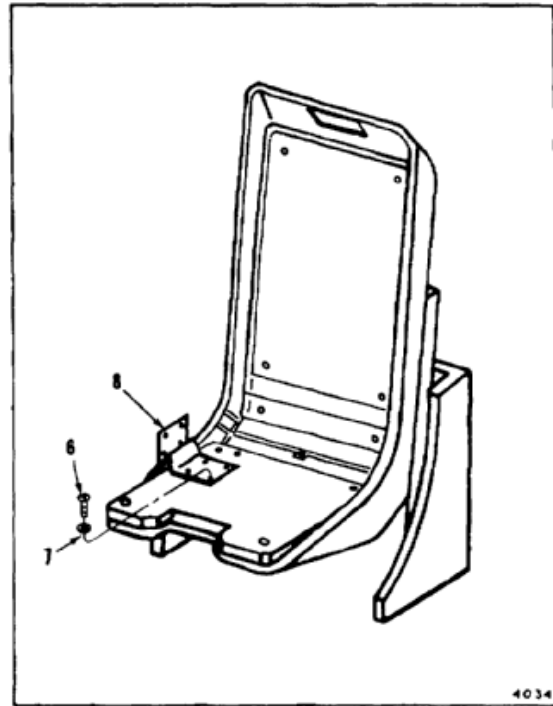

4. Remove nut (9), washers (10), and screw (11) from each forward corner of seat. Remove forward bottom armor panel (14).

**FOLLOW-ON MAINTENANCE:**

None

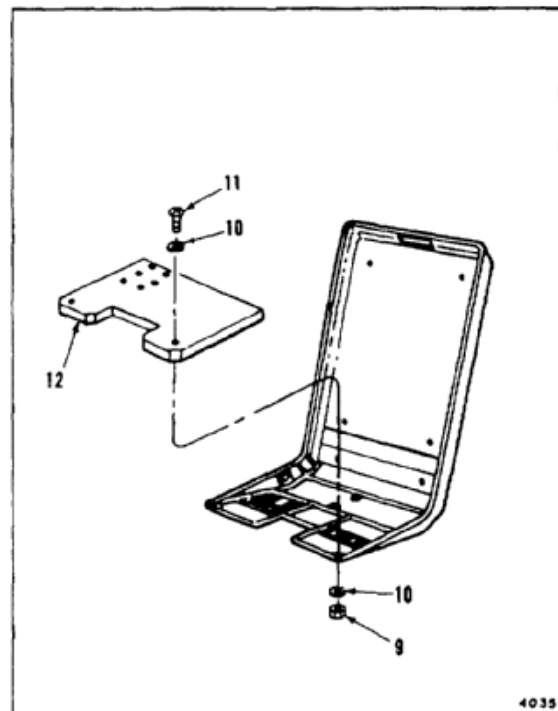

END OF TASK

16-269

## INITIAL SETUP

**Applicable Configurations:**

With 7

**Tools:**

Aircraft Mechanic's Tool Kit, NSN 5180-00-323-4692

**Materials:**

None

**Personnel Required:**

Medium Helicopter Repairer

**Equipment Condition:**

Battery Disconnected (Task 1-39)  
 Electrical Power Off  
 Hydraulic Power Off

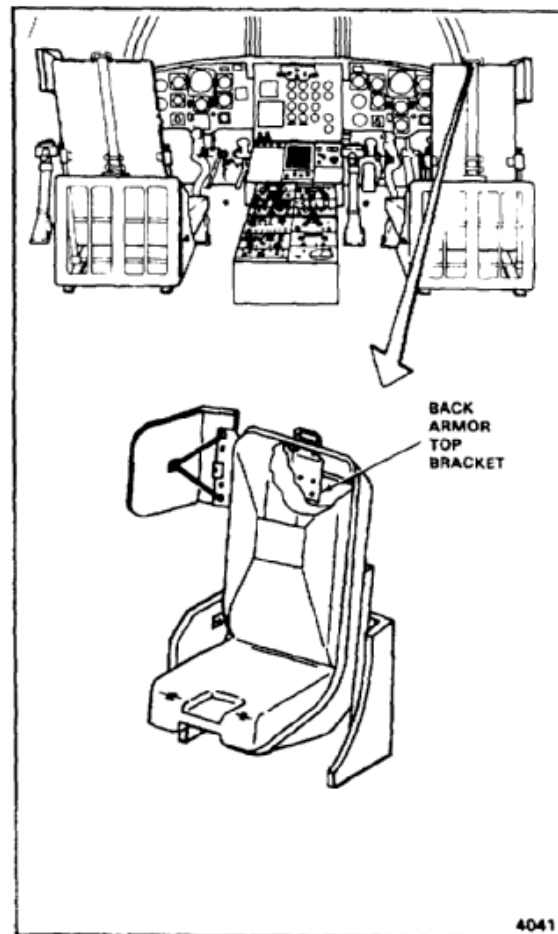
**NOTE**

Procedures are same for removing pilot's or copilot's seat bracket. Pilot's seat shown here.

1. Unsnap four fasteners (1) from seat bucket (2).
2. Separate hook taps (3) from pile tape (4). Remove cushion (5).

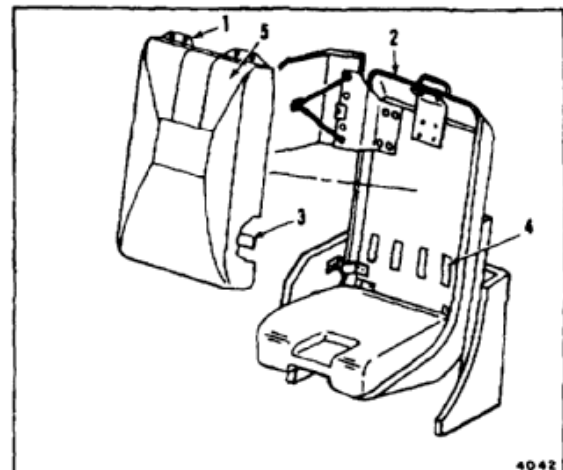



**16-70 REMOVE BACK ARMOR TOP BRACKET (Continued)****16-70**

3. Remove two nuts (6) and washers (7). Remove harness guide (8) from bracket (9).
4. Remove four screws (10) and washers (11). Remove bracket (9).

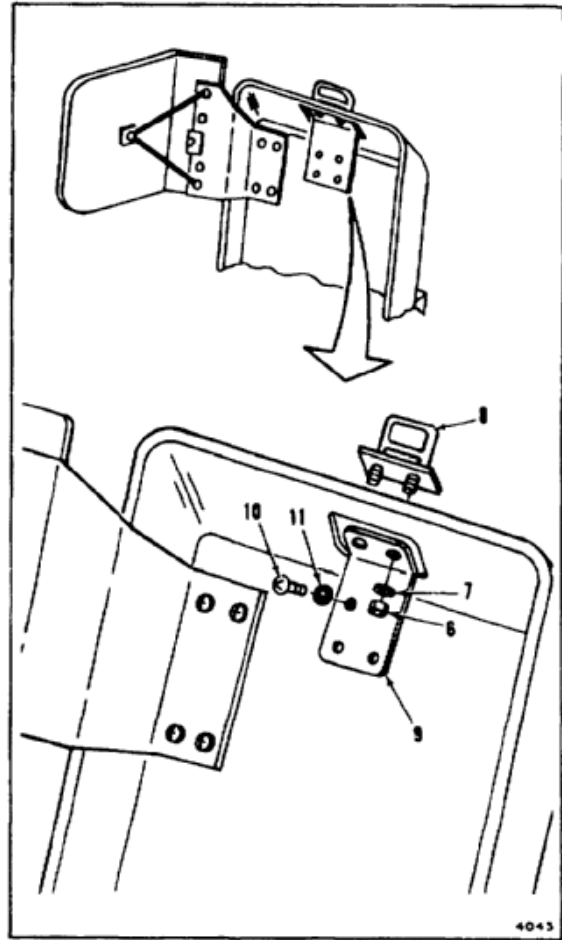
***FOLLOW-ON MAINTENANCE:***

None

END OF TASK

INITIAL SETUP

**Applicable Configurations:**

With **7**

**Tools:**

Aircraft Mechanic's Tool Kit, NSN 5180-00-323-4692

**Materials:**

None

**Personnel Required:**

Medium Helicopter Repairer

**References:**

TM 55-1520-240-23P

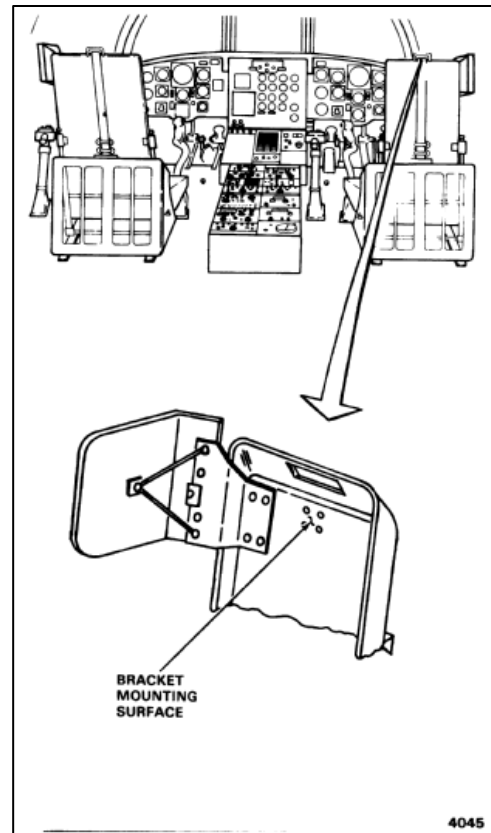

**NOTE**

Procedures are same for installing pilot's or copilot's seat bracket. Pilot's seat shown here.

1. Position bracket (1) on back armor panel (2). Install four screws (3) and washers (4).
2. Position harness guide (5) on bracket (1). Install two nuts (6) and washers (7).

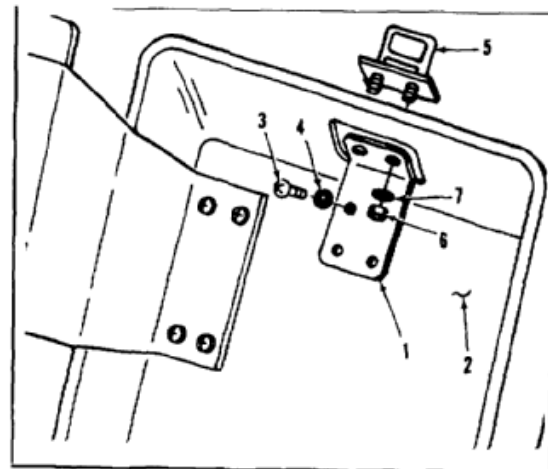

**16-71 INSTALL BACK ARMOR TOP BRACKET (Continued)****16-71**

3. Position back seat cushion (8) on armor panel (2).
4. Snap four fasteners (9) to back of seat bucket (10). Press against cushion (8) so that hook tape (11) sticks to pile tape (12).

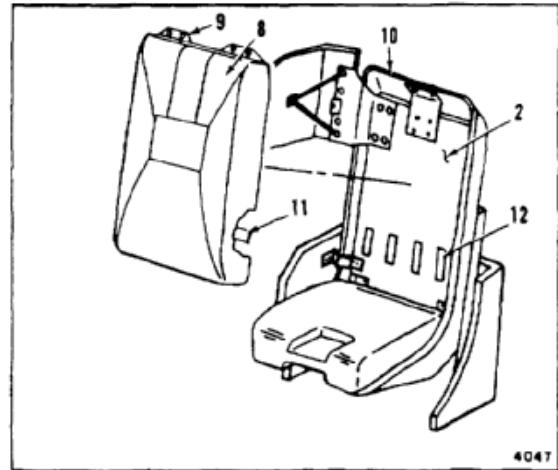
***FOLLOW-ON MAINTENANCE:***

None

END OF TASK

## INITIAL SETUP

**Applicable Configurations:**With **7****Tools:**

Aircraft Mechanic's Tool Kit, NSN 5180-00-323-4692

**Materials:**

None

**Personnel Required:**

Medium Helicopter Repairer

**Equipment Condition:**

Battery Disconnected (Task 1-39)  
 Electrical Power Off  
 Hydraulic Power Off

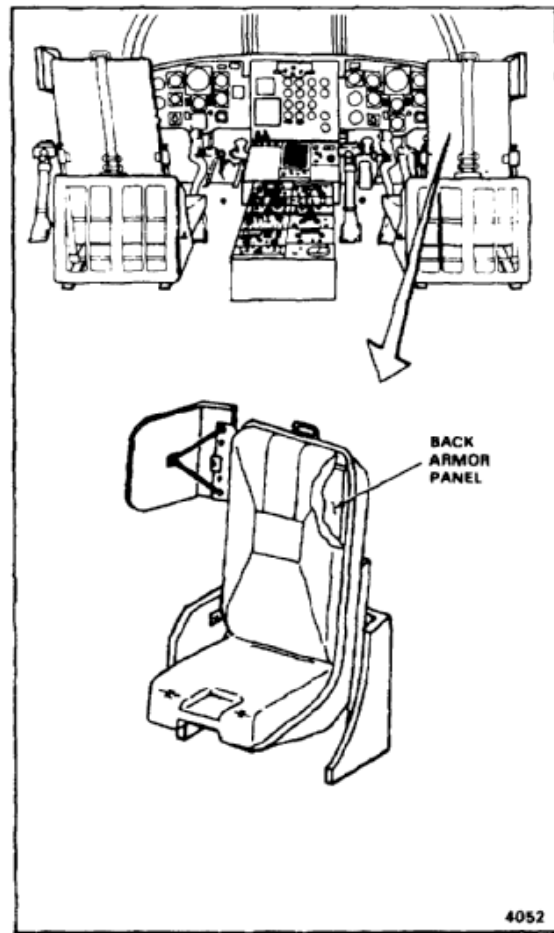
**NOTE**

Procedures are same for removing pilot's or copilot's seat armor. Pilot's seat shown here.

1. Unsnap four fasteners (1) from seat bucket (2).
2. Separate hook tape (3) from pile tape (4). Remove cushion (5).
3. Unsnap four fasteners (6) from seat bucket (2). Lift off cushion (7).

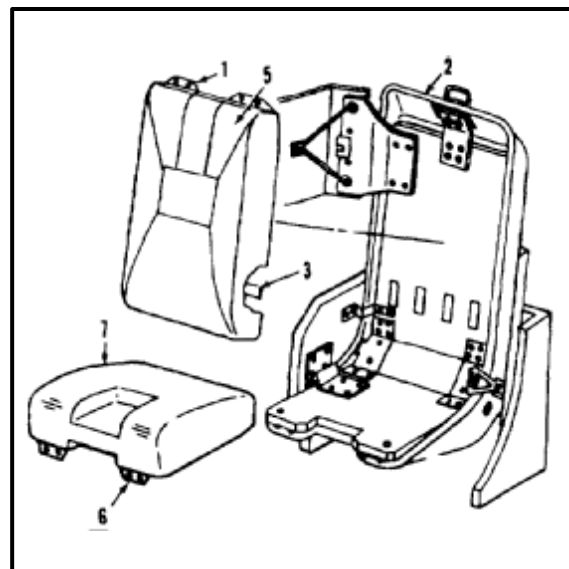

**16-72 REMOVE BACK ARMOR PANEL (Continued)****16-72**

4. Remove two screws (8) and washers (9) from side armor aft bracket (10).
5. Remove four screws (11) and washers (12) from side armor forward bracket (13). Remove panel (14).

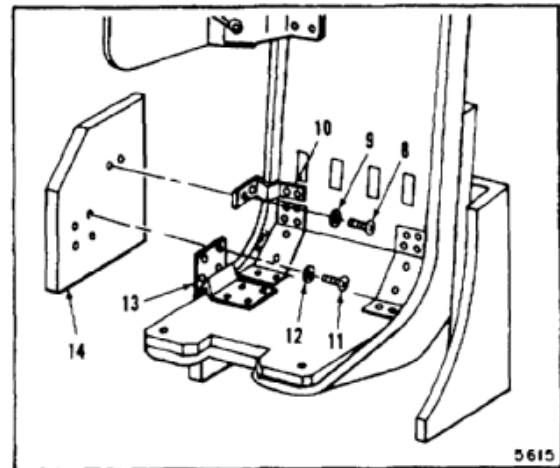

6. Remove nut (15), washers (16 and 17), and bolt (18) from each side of seat bucket (2). Remove seat belt fittings (19).

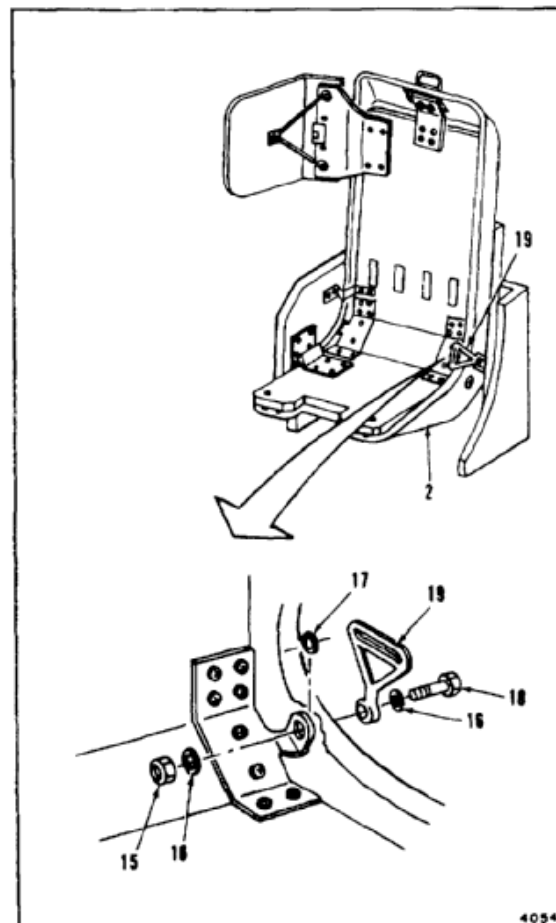

7. Remove eight screws (20) and washers (21) from two aft bottom armor brackets (22). Remove brackets.
8. Remove four screws (23) and washers (24) from side armor aft bracket (25). Remove bracket.

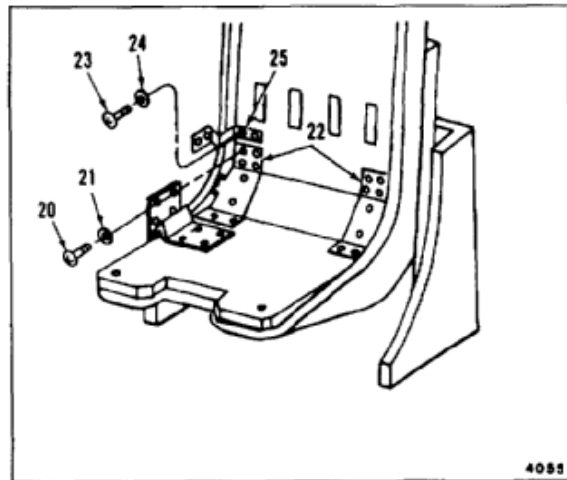

9. Remove shoulder armor panel (26) and mounting plate assembly (27) as follows:
  - a. Disconnect exerciser cord (28) from mounting plate assembly (27).

**NOTE**

Pilot's seat hinge has four screws.  
 Copilot's seat hinge has three screws.

- b. Swing shoulder armor panel (26) aft. Support panel and remove screws from hinge half (30).
- c. Remove panel (26), hinge half (30), and spacer (31) from mounting plate assembly (27).
- d. Remove four screws (32) and washers (33). Remove mounting plate assembly (27).

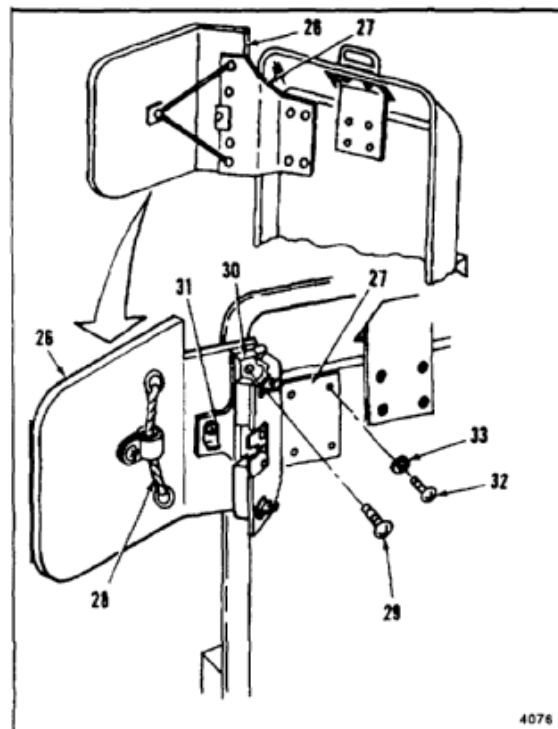

**16-72 REMOVE BACK ARMOR PANEL (Continued)**

16-72

10. Remove top bracket (34) as follows:
  - a. Remove two nuts (35) and washers (36). Remove harness guide (37) from bracket (34).
  - b. Remove four screws (38) and washers (39). Remove bracket (34).

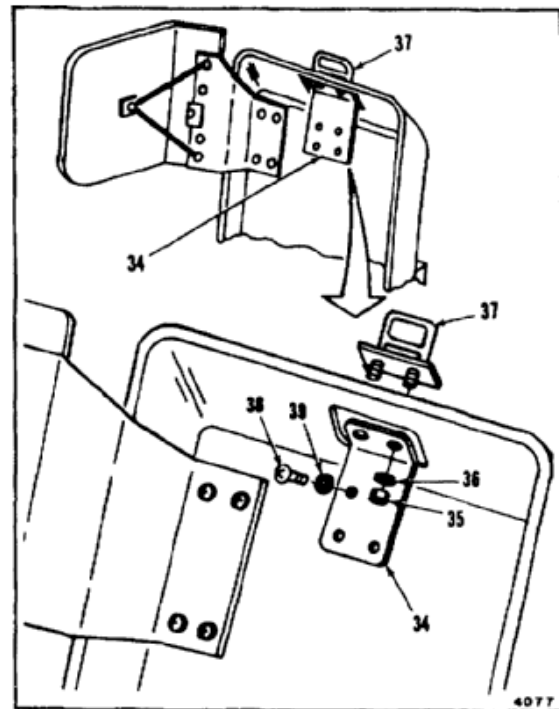

11. Remove back armor panel (40).

**FOLLOW-ON MAINTENANCE:**

None

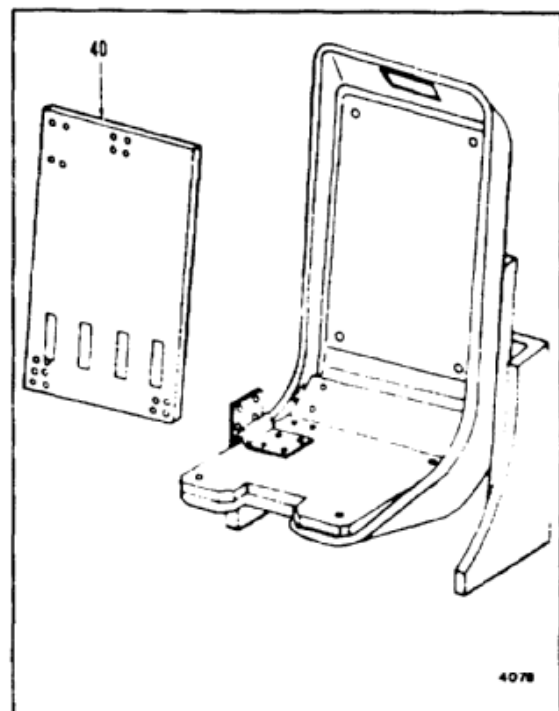

END OF TASK

INITIAL SETUP

**Applicable Configurations:**

With **7**

**Tools:**

Aircraft Mechanic's Tool Kit, NSN 5180-00-323-4692

**Materials:**

None

**Parts:**

Medium Helicopter Mechanic

**References:**

TM 55-1520-240-23P

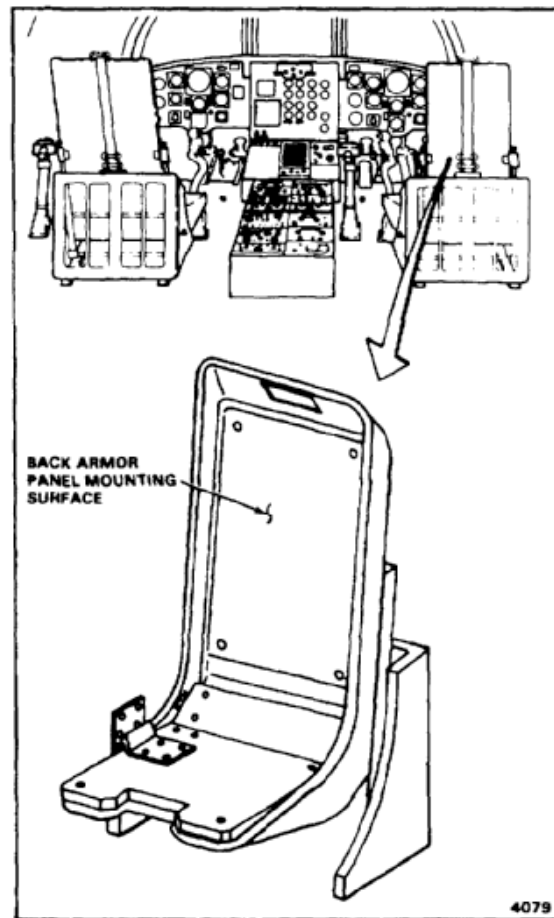

**NOTE**

Procedures are same for installing pilot's or copilot's seat back armor panel. Pilot's seat shown here.

1. Position back armor panel (1) against back of seat (2).

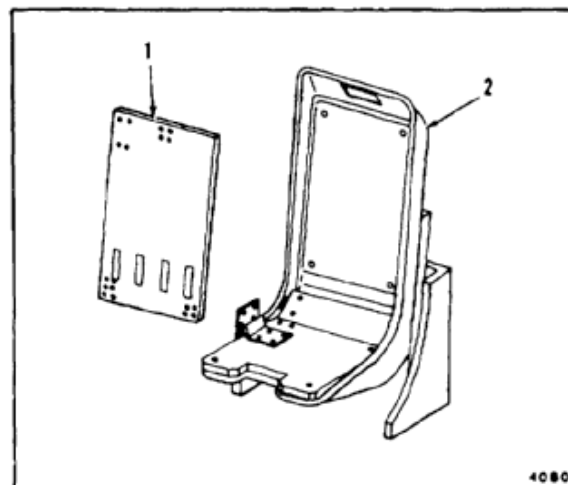



2. Install top bracket (3) as follows:
  - a. Install bracket (3) on seat bucket (4). Use four screws (5) and washers (6).
  - b. Install harness guide (7) on bracket (3). Install two nuts (8) and washers (9).

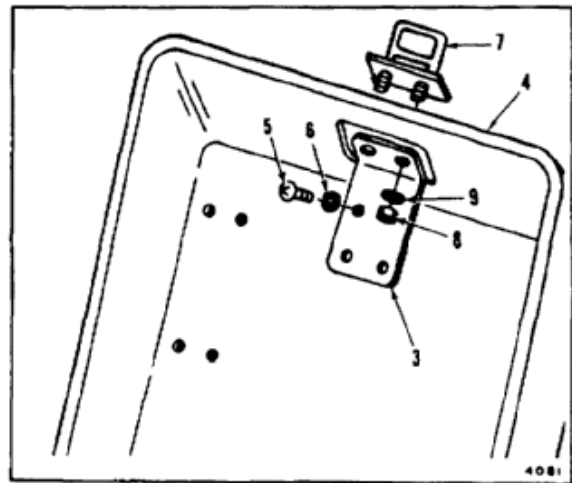

3. Install mounting plate assembly (10) and shoulder armor panel (11) as follows:
  - a. Install mounting plate assembly (10) on back armor panel (1). Use four screws (12) and washers (13).
  - b. Remove hinge pin (14) from hinge halves (15 and 16) on mounting plate assembly (10).
  - c. Position spacer (17) on shoulder armor panel (11). Leave top insert (18) unused.

**NOTE**

Pilot's seat hinge has four screws.  
 Copilot's seat hinge has three screws.

- d. Position hinge half (15) over spacer (17). Install screws (19).
- e. Align hinge halves (15 and 16). Install hinge pin (14).

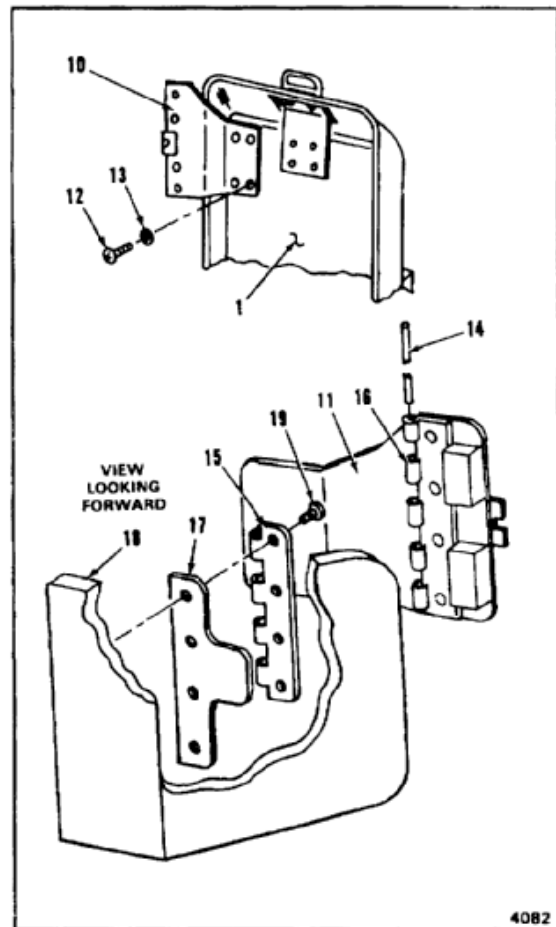

- f. Rotate shoulder armor panel (11) forward until spring latch (20) engages striker plate (21). If needed, bend spring latch slightly.
- g. Hook rings of each end of exerciser cord (22) to eyebolts (23) on mounting plate assembly (24).

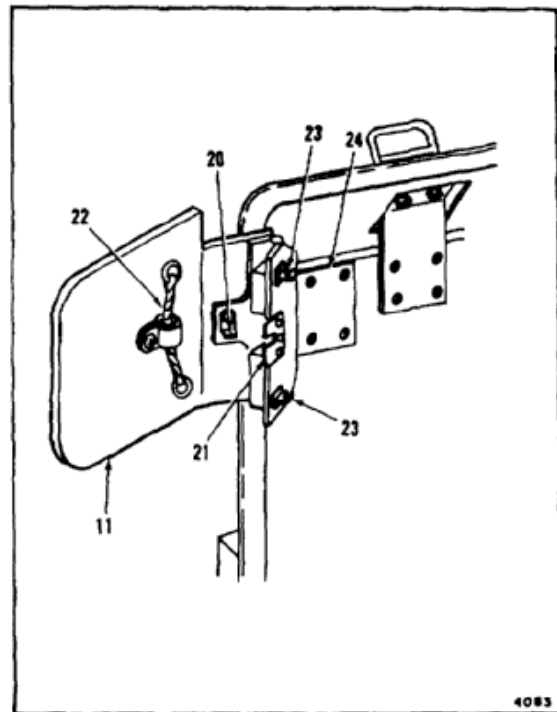

- 4. Install two aft bottom armor brackets (25) on seat. Use eight screws (26) and washers (27) on each bracket.
- 5. Install side armor aft bracket (28) on back armor panel (29). Use two screws (30) and washers (31).

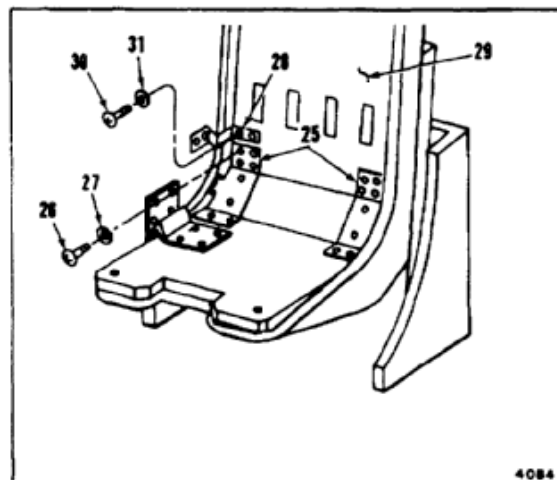

**16-73 INSTALL BACK ARMOR PANEL (Continued)**

16-73

6. Position side armor panel (52) against forward bracket (33) and aft bracket (28). Install four screws (34) and washers (35).
7. Install two screws (36) and washers (37).

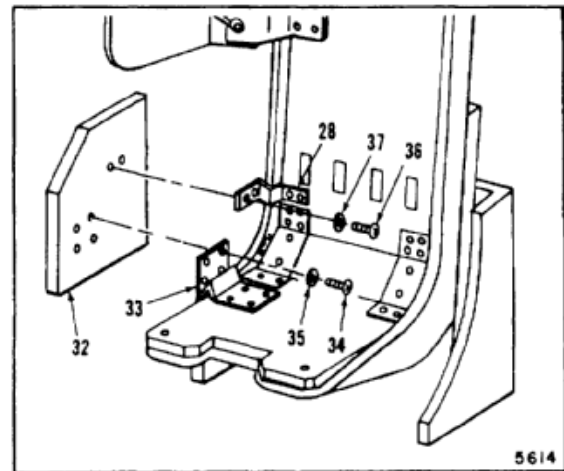

8. Install seat belt fitting (38) on each side of seat bucket (2). Install bolt (39), washers (40 and 41), and nut (42).

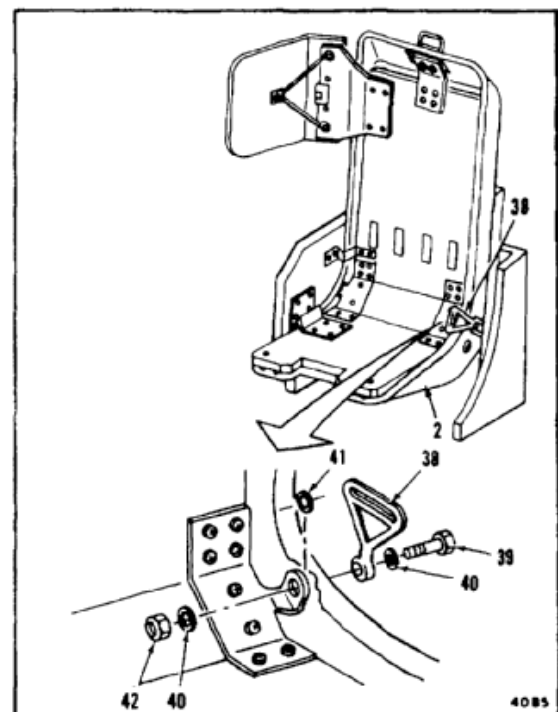

9. Set bottom cushion (43) on bottom armor (44). Snap four fasteners (45).
10. Set back cushion (46) against back armor panel (1). Snap four fasteners (47).
11. Press against cushion (46) to secure hook tape (48) on cushion to pile tape (49) on armor (1).

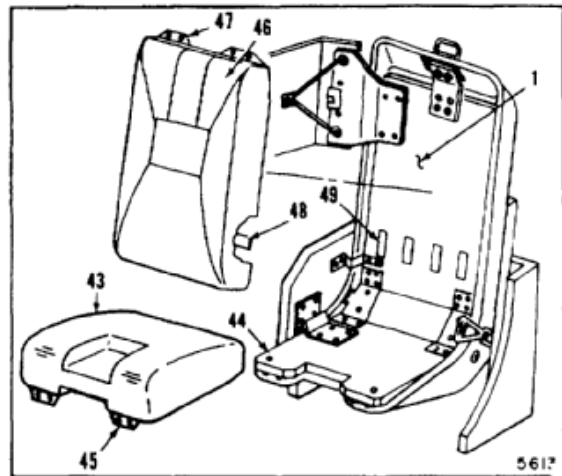
**FOLLOW-ON MAINTENANCE:**

None

END OF TASK

16-282

## INITIAL SETUP

**Applicable Configurations:**With **7****Tools:**

Aircraft Mechanic's Tool Kit, NSN 51 80-00-323-4692

**Materials:**

None

**Personnel Required:**

Medium Helicopter Repairer

**Equipment Condition:**

Battery Disconnected (Task 1-39)  
 Electrical Power Off  
 Hydraulic Power Off

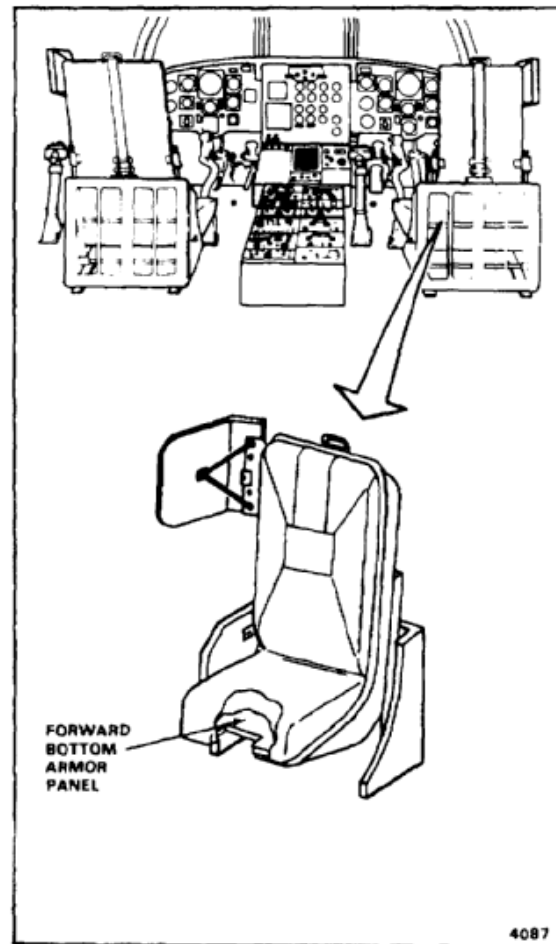
**NOTE**

Procedures are same for removing pilot's or copilot's seat armor. Pilot's seat shown here.

1. Unsnap four fasteners (1) from seat bucket (2).
2. Separate hook tape (3) from pile tape (4). Remove cushion (5).

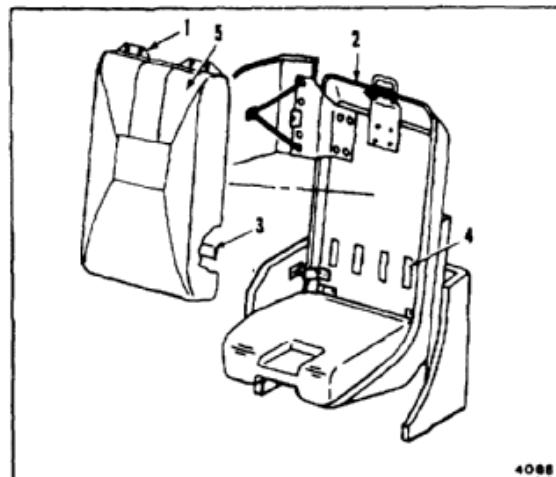

3. Unsnap four fasteners (6) from seat bucket (2). Lift off cushion (7).
4. Remove nut (8), washers (9 and 10), and bolt (11) from each side of seat bucket (2). Remove seat belt fittings (12).

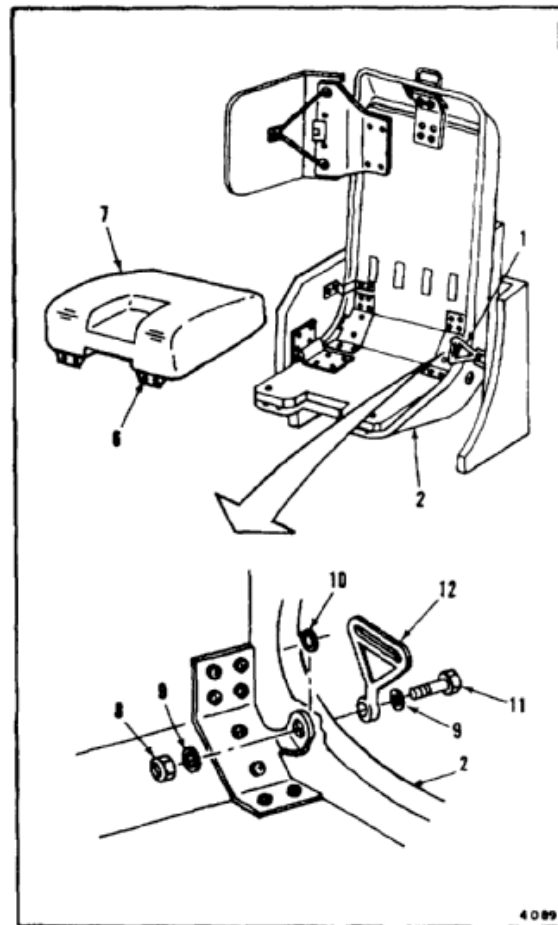

5. Remove six screws (13) and washers (14) from two aft bottom armor brackets (15). Remove brackets.
6. Remove two screws (16) and washers (17) from side armor aft bracket (18).
7. Remove four screws (19) and washers (20) from side armor forward bracket (21). Remove side armor panel (22).
8. Remove nut (23), washers (24), and screw (25) from each forward corner of panel (26).

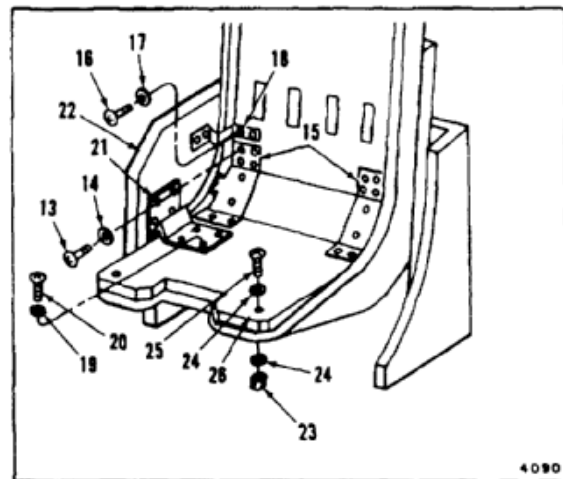

9. Remove panel (26) from seat bucket (2).

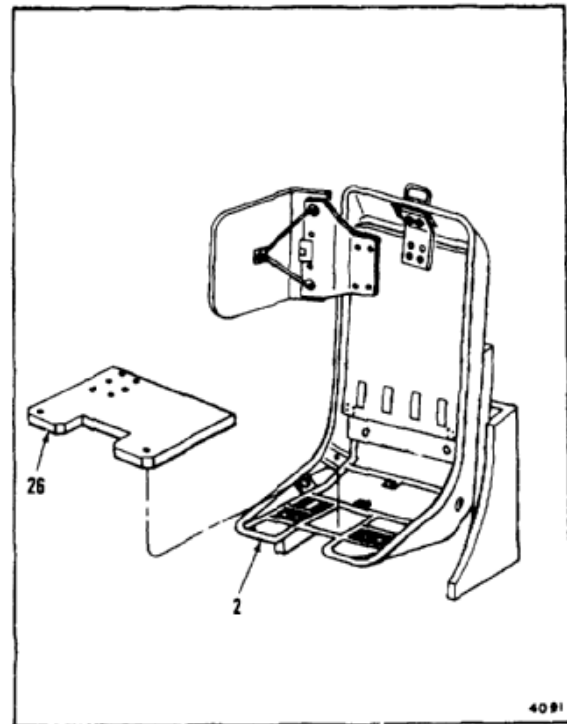

***FOLLOW-ON MAINTENANCE:***

None

END OF TASK

INITIAL SETUP

**Applicable Configurations:**

With **7**

**Tools:**

Aircraft Mechanic's Tool Kit, NSN 5180-00-323-4692

**Materials:**

None

**Personnel Required:**

Medium Helicopter Repairer

**References:**

TM 55-1520-240-23P

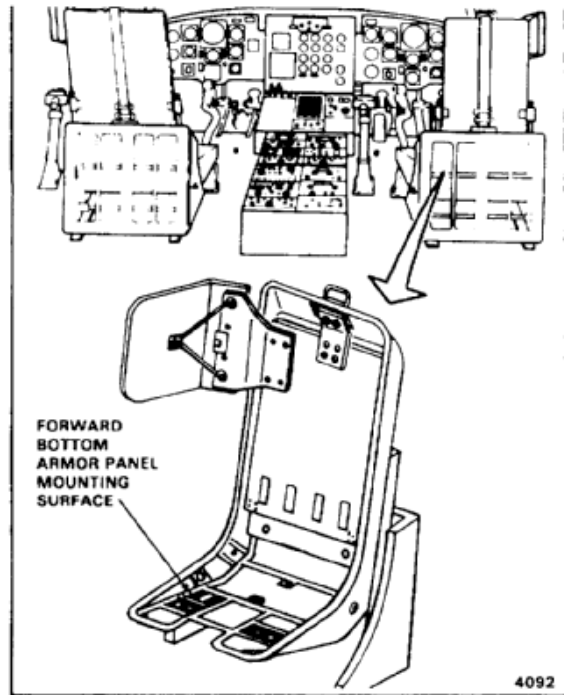

**NOTE**

Procedures are same for installing pilot's or copilot's seat armor.

1. Check that spacers (1) are installed in forward corners of seat bucket (2).
2. Install armor panel (3) in seat bucket (2).
3. Install screw (4), washers (5), and nut (6) in each forward corner of panel (3).

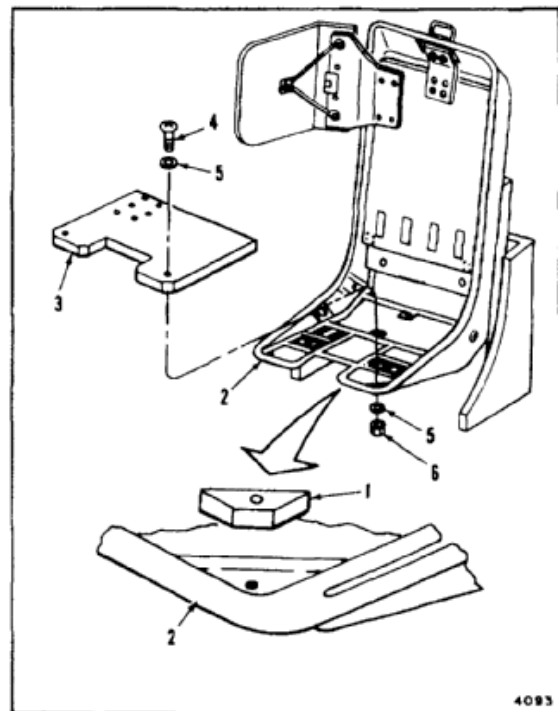



**16-75 INSTALL FORWARD BOTTOM ARMOR PANEL (Continued)**

16-75

4. Install side armor panel (7) on seat bucket (2). Use four screws (8) and washers (9) in forward bracket (10).
5. Install two screws (11) and washers (12) through aft bracket (13).
6. Install two aft bottom armor brackets (14) on seat. Install six screws (15) and washers (16) in each bracket.

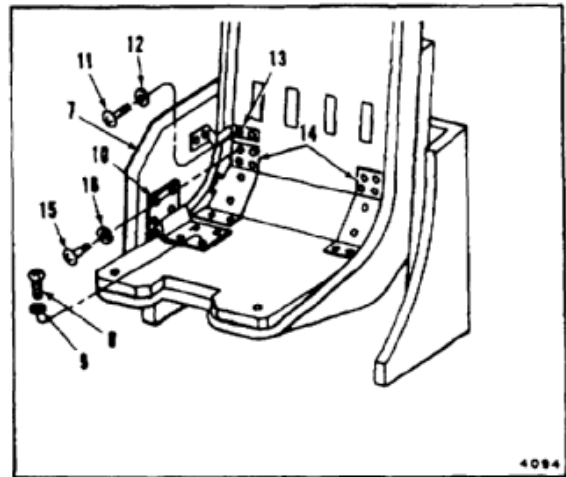

7. Position seat belt fitting (17) on each side of seat bucket (2). Install bolt (18), washers (19 and 20), and nut (21).
8. Set bottom cushion (22) on bottom armor panel (23). Snap four fasteners (24).

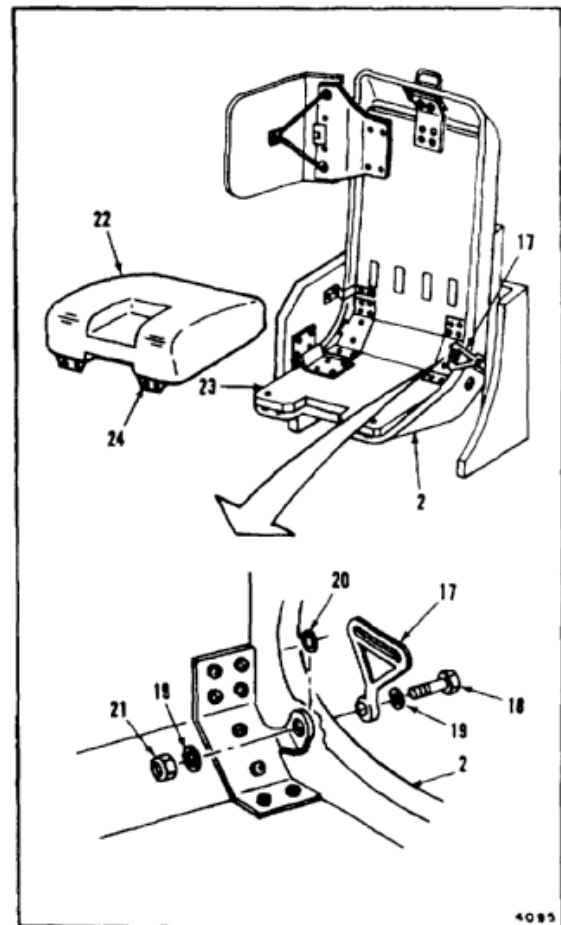

9. Set back cushion (25) against back armor panel (26). Snap four fasteners (27).
10. Press against cushion (25) to secure hook tape (28) on cushion to pile tape (29) on armor (26).

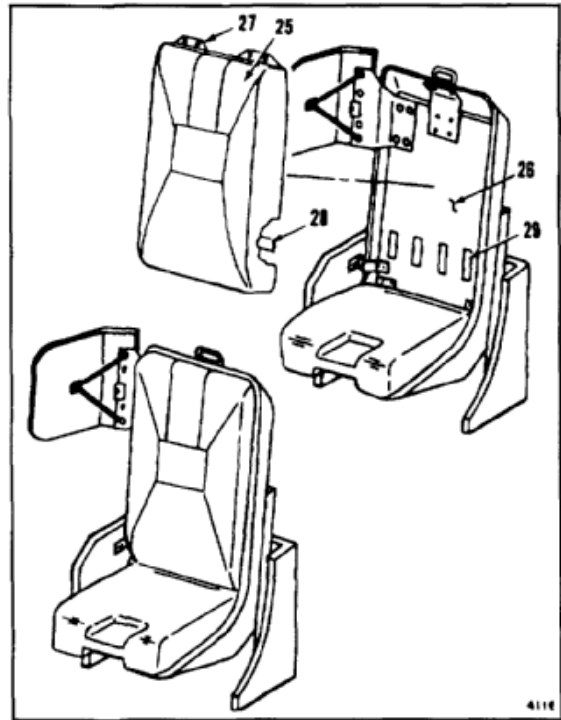
**FOLLOW-ON MAINTENANCE:**

None

END OF TASK

16-288

**16-76 REMOVE AFT BOTTOM ARMOR PANEL**

16-76

**INITIAL SETUP****Applicable Configurations:**With **7****Tools:**

Aircraft Mechanic's Tool Kit, NSN 51 80-00-323-4692

**Materials:**

None

**Personnel Required:**

Medium Helicopter Repairer

**Equipment Condition:**

Battery Disconnected (Task 1-39)  
 Electrical Power Off  
 Hydraulic Power Off

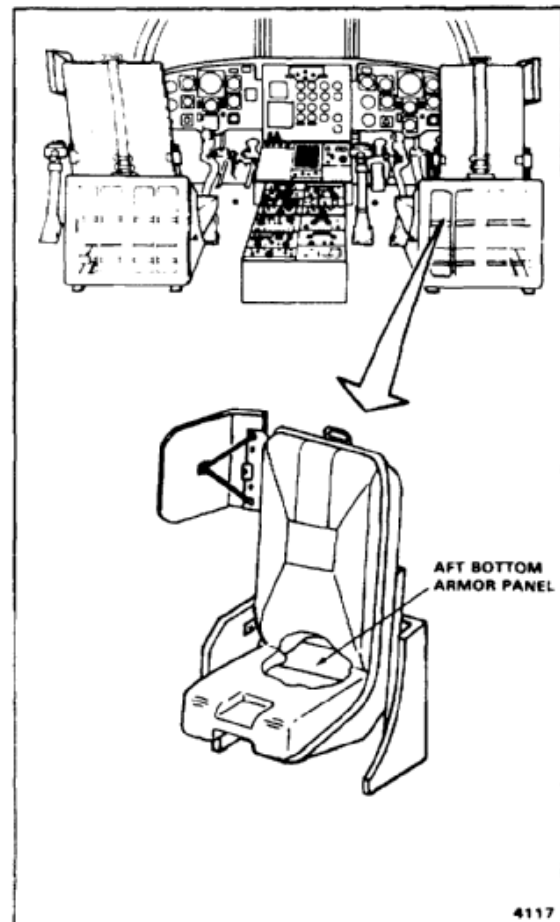
**NOTE**

Procedures are same for removing pilot's or copilot's seat armor. Pilot's seat shown here.

1. Unsnap four fasteners (1) from seat bucket (2).
2. Separate hook tape (3) from pile tape (4).  
Remove cushion (5).

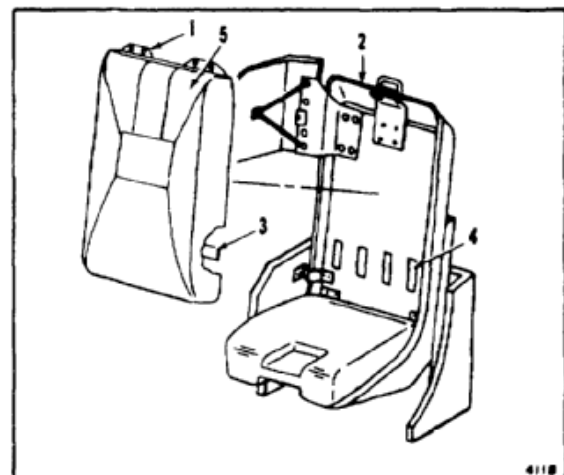

3. Unsnap four fasteners (6) from seat bucket (2). Lift off cushion (7).
4. Remove nut (8), washers (9 and 10), and bolt (11) from each side of seat bucket (2). Remove seat belt fittings (12).

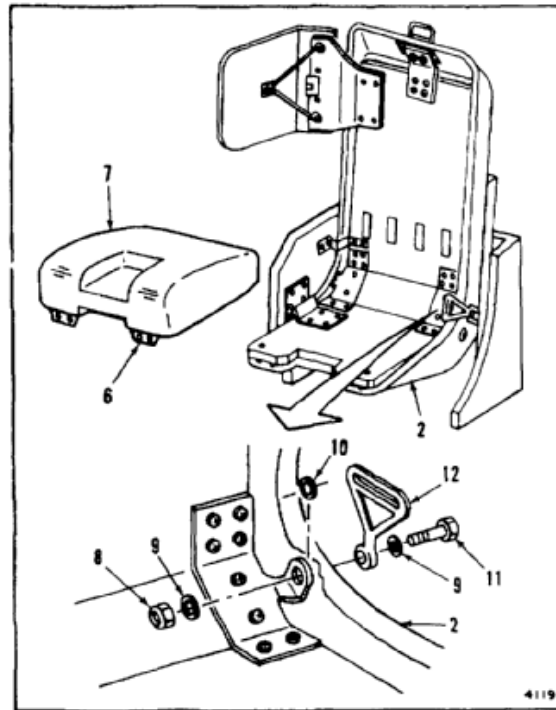

5. Remove eight screws (13) and washers (14) from two aft bottom armor brackets (15). Remove brackets.
6. Remove aft bottom armor panel (16).

**FOLLOW-ON MAINTENANCE:**

None

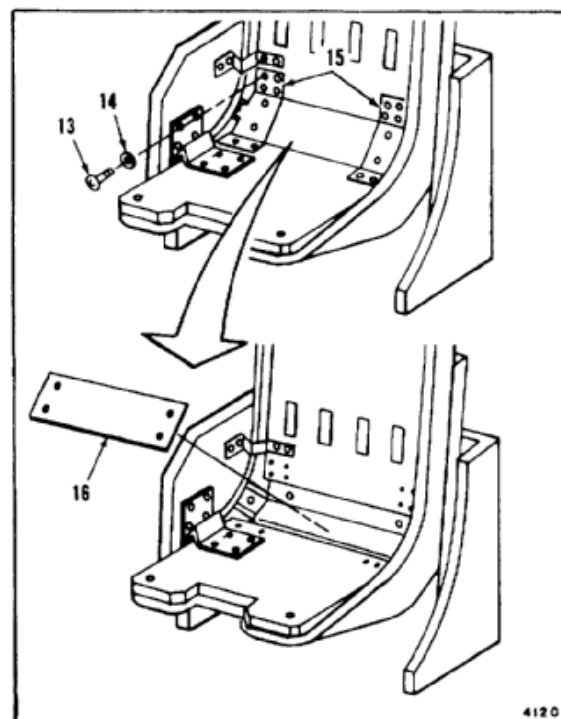

END OF TASK

## INITIAL SETUP

**Applicable Configurations:**With **7****Tools:**

Aircraft Mechanic's Tool Kit, NSN 51 80-00-323-4692

**Materials:**

None

**Personnel Required:**

Medium Helicopter Repairer

**References:**

TM 55-1520-240-23P

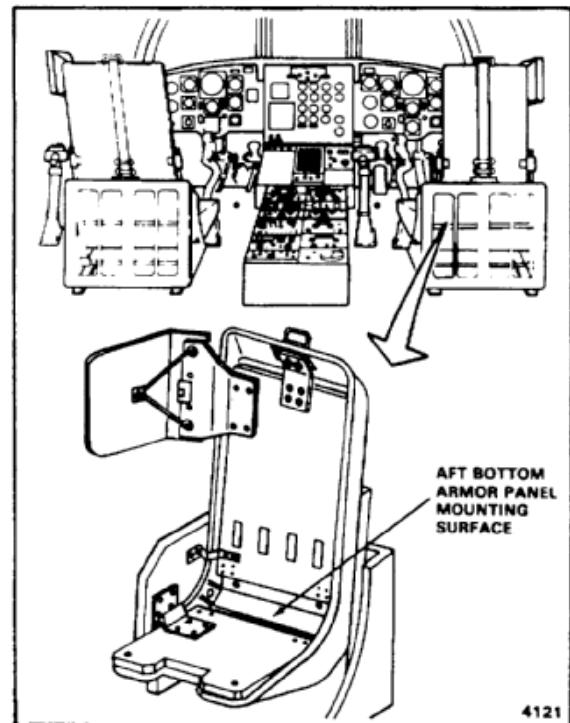
**NOTE**

Procedures are same for installing pilot's or copilot's seat armor. Pilot's seat shown here.

1. Install aft bottom armor panel (1) between forward bottom armor panel (2) and back armor panel (3).
2. Install two brackets (4) on seat. Use eight screws (5) and washers (6) on each bracket.

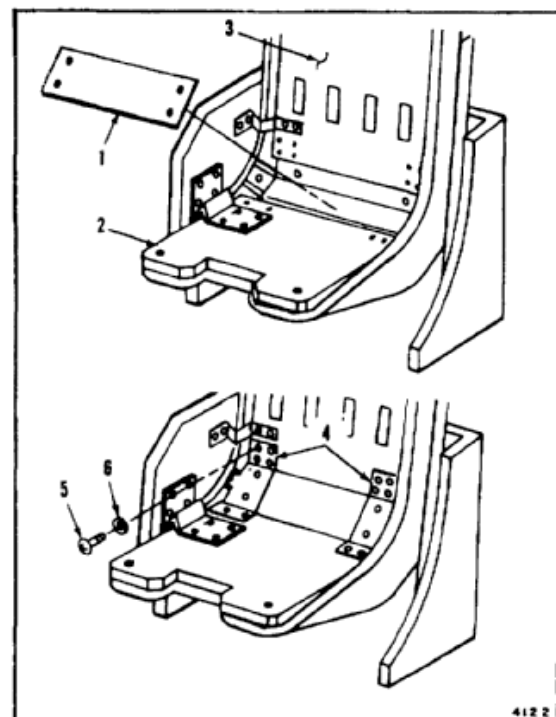

3. Install seat belt fitting (7) on each side of seat. Use bolt (8), washers (9 and 10), and nut (11).
4. Set bottom cushion (12) on bottom armor panel (2). Snap four fasteners (13).

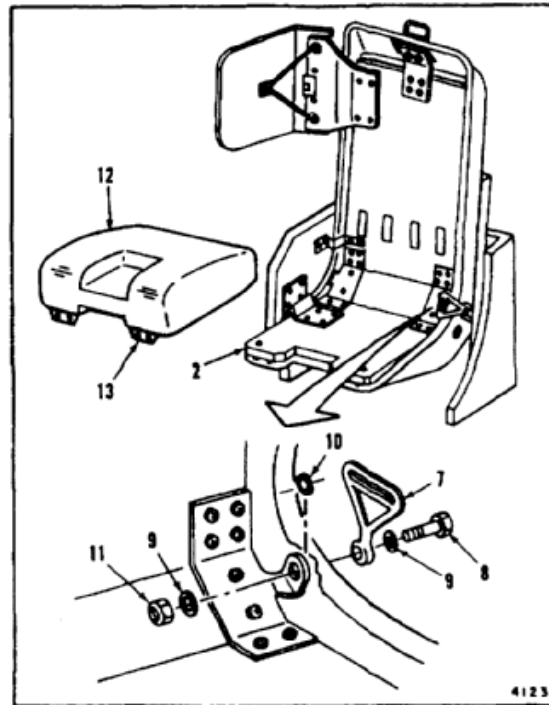

5. Set back cushion (14) against back armor panel (3). Snap four fasteners (15).
6. Press against cushion (14) to secure hook tape (16) on cushion to pile tape (17) on armor (3).

**FOLLOW-ON MAINTENANCE:**

None

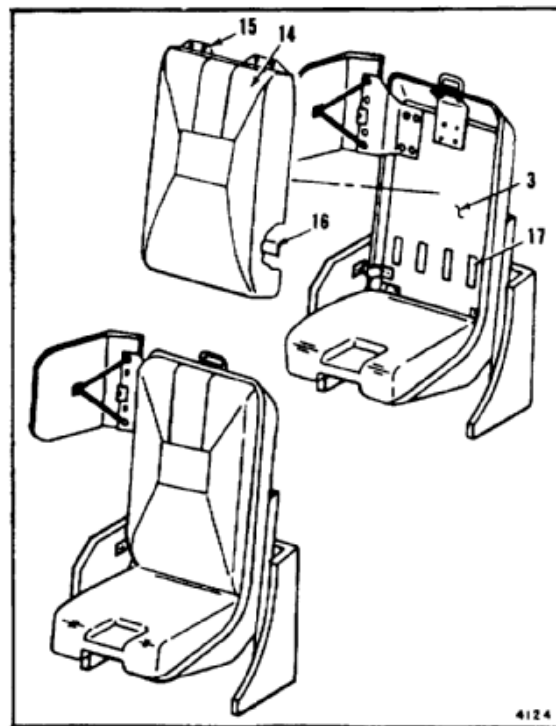

END OF TASK

## INITIAL SETUP

**Applicable Configurations:**With **7****Tools:**

Aircraft Mechanic's Tool Kit, NSN 51 80-00-323-4692

**Materials:**

None

**Personnel Required:**

Medium Helicopter Repairer

**Equipment Condition:**

Battery Disconnected (Task 1-39)  
 Electrical Power Off  
 Hydraulic Power Off

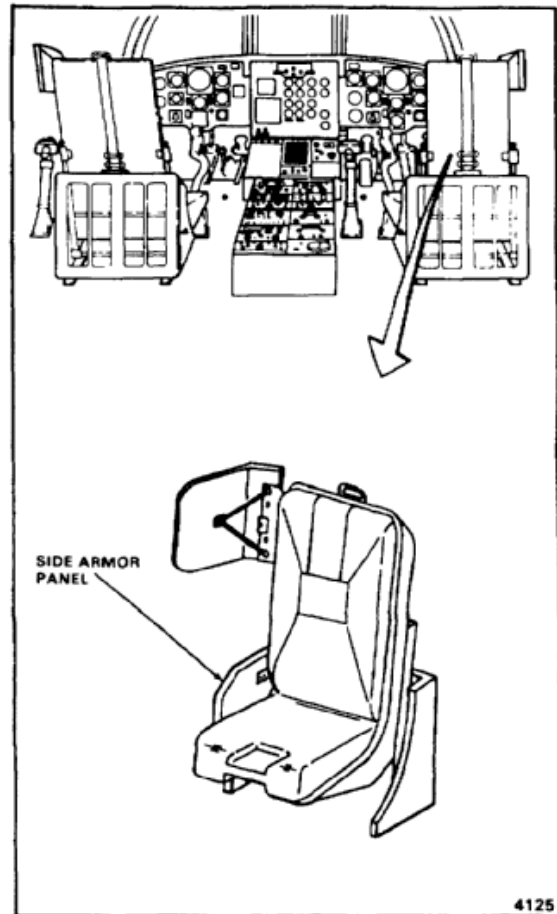
**NOTE**

Procedures are same for removing pilot's or copilot's seat armor. Pilot's seat shown here.

1. Unsnap four fasteners (1) from seat bucket (2).
2. Separate hook tape (3) from pile tape (4).  
Remove cushion (5).

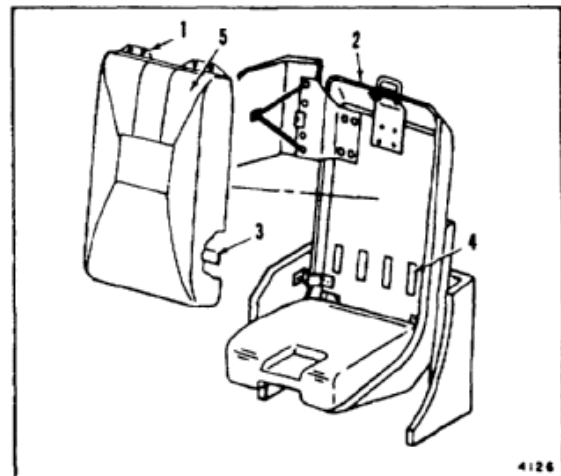

3. Unsnap four fasteners (6) from seat bucket (2).  
Lift off cushion (7).

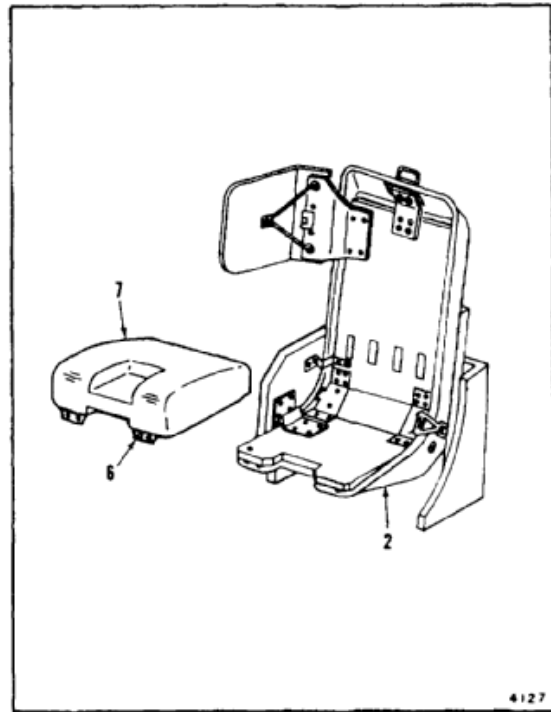

4. Remove two screws (8) and washers (9) from side armor aft bracket (10).
5. Remove four screws (11) and washers (12) from side armor forward bracket (13). Remove bracket (14).

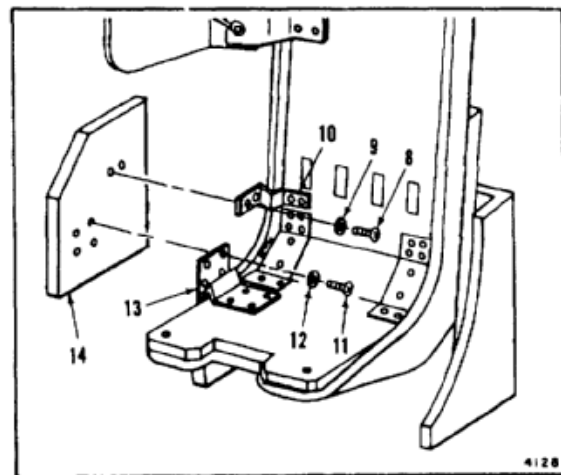
**FOLLOW-ON MAINTENANCE:**

None

END OF TASK

16-294



INITIAL SETUP

**Applicable Configurations:**

With **7**

**Tools:**

Aircraft Mechanic's Tool Kit, NSN 51 80-00-323-4692

**Materials:**

None

**Personnel Required:**

Medium Helicopter Repairer

**References:**

TM 55-1520-240-23P

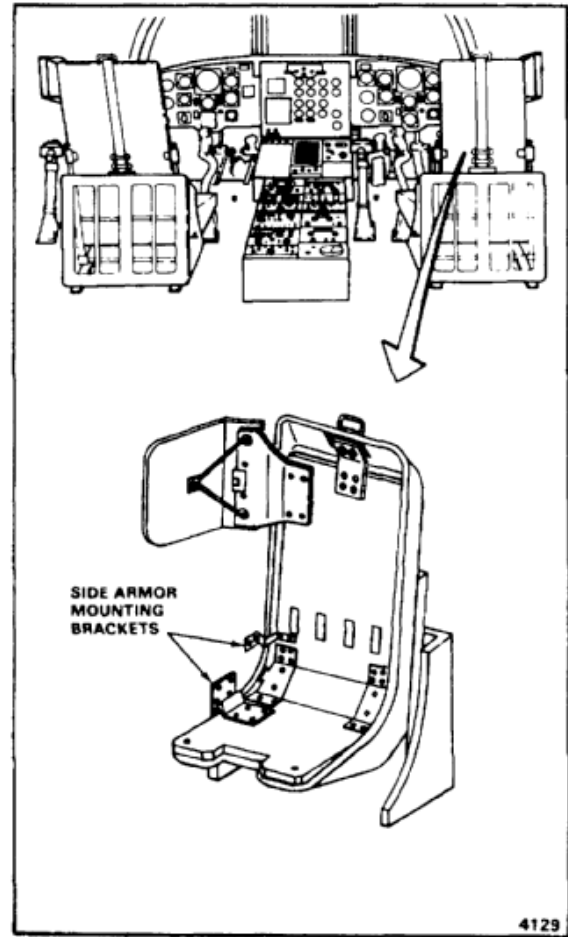

**NOTE**

Procedures are same for installing pilot's or copilot's seat armor. Pilot's seat shown here.

1. Install side armor panel (1) against forward bracket (2) and aft bracket (3). Use four screws (4) and washers (5).
2. Install two screws (6) and washers (7).

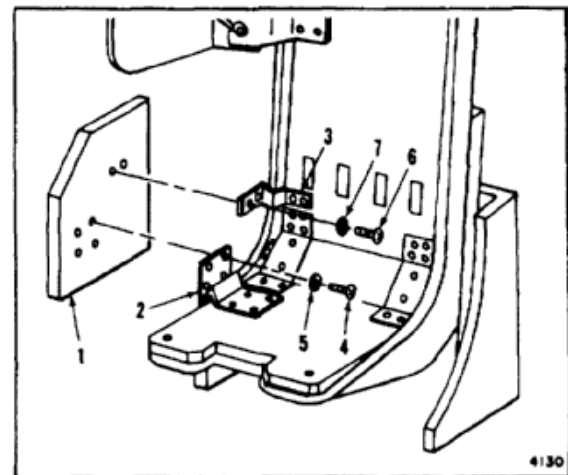

3. Set bottom cushion (8) on bottom armor panel (9). Snap four fasteners (10).

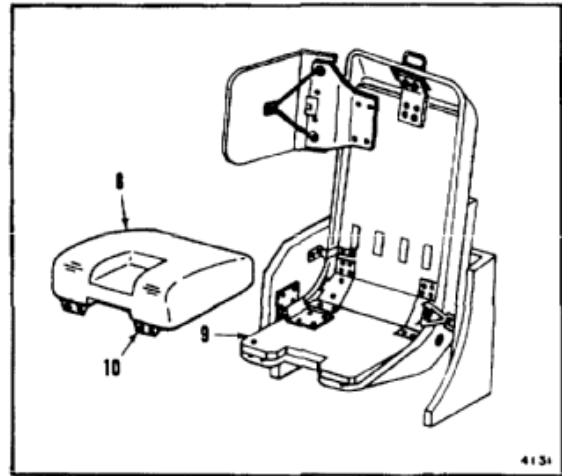

4. Set back cushion (11) against back armor panel (12). Snap four fasteners (13).
5. Press against cushion (11) to secure hook tape (14) on cushion to pile tape (15) on armor (12).

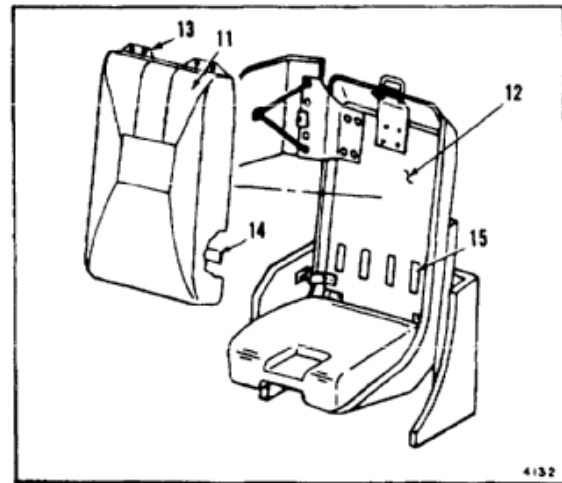
**FOLLOW-ON MAINTENANCE:**

None

END OF TASK

16-296

## INITIAL SETUP

**Applicable Configurations:**With **7****Tools:**

Aircraft Mechanic's Tool Kit, NSN 51 80-00-323-4692

**Materials:**

None

**Personnel Required:**

Medium Helicopter Repairer

**Equipment Condition:**

Battery Disconnected (Task 1-39)  
 Electrical Power Off  
 Hydraulic Power Off

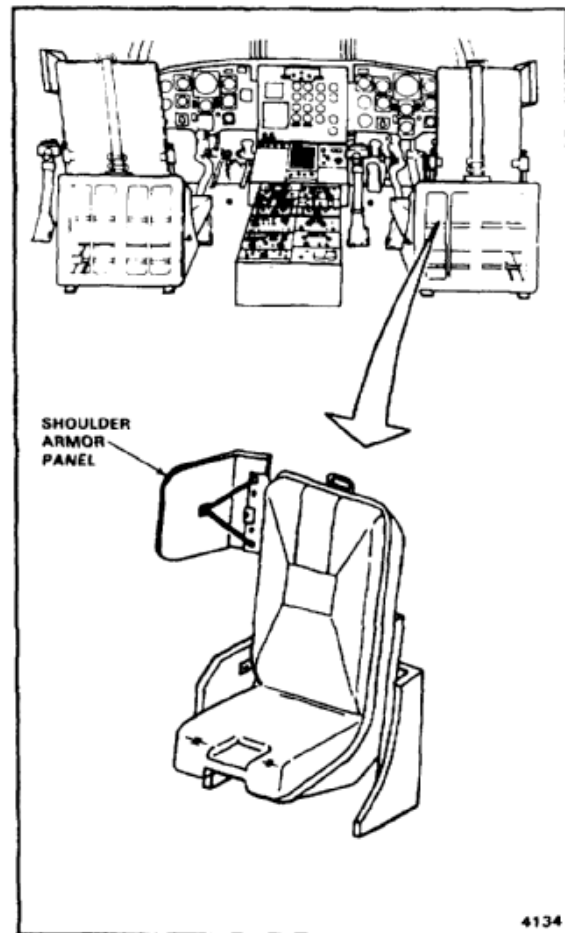
**NOTE**

Procedures are same for removing pilot's or copilot's seat bracket. Pilot's seat shown here.

1. Unsnap four fasteners (1) from seat bucket (2).
2. Separate hook tape (3) from pile tape (4).  
Remove cushion (5).

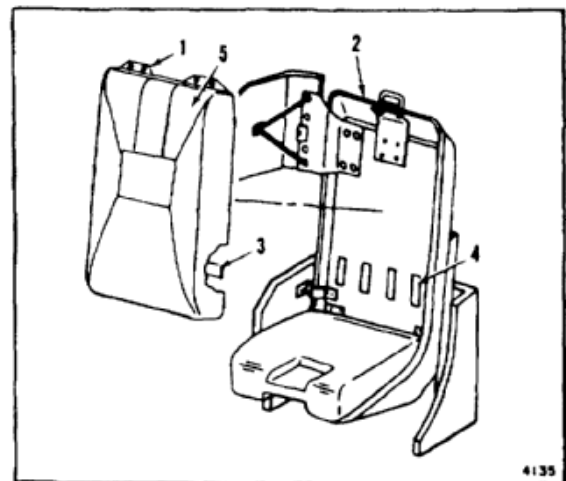

3. Disconnect exerciser cord (6) from mounting plate assembly (7).

**NOTE**

Pilot's seat hinge has four screws.  
Copilot's seat hinge has three.

4. Swing shoulder armor panel (8) aft. Support panel and remove screws (9) from hinge half (10).
5. Remove panel (8), hinge half (10), and spacer (11) from mounting plate assembly (7).
6. Remove four screws (12) and washers (13). Remove mounting plate assembly (7).

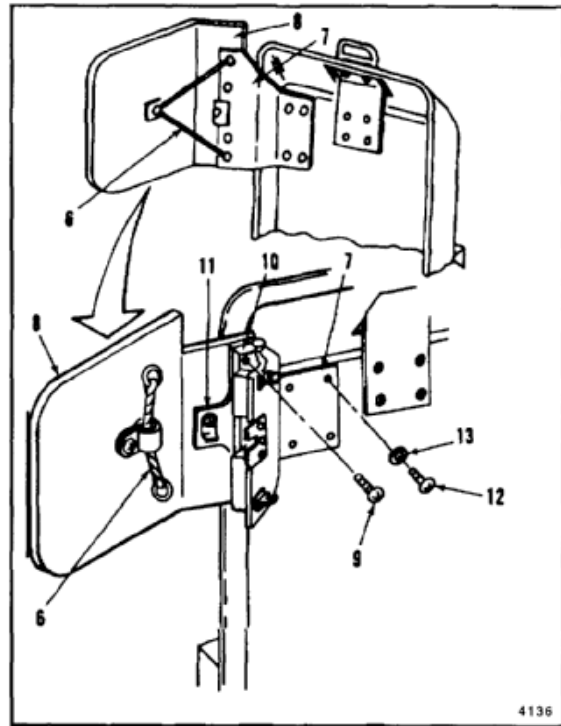

**FOLLOW-ON MAINTENANCE:**

None

END OF TASK

## INITIAL SETUP

**Applicable Configurations:**With **7****Tools:**

Aircraft Mechanic's Tool Kit, NSN 51 80-00-323-4692

**Materials:**

None

**Personnel Required:**

Medium Helicopter Repairer

**References:**

TM 55-1520-240-23P

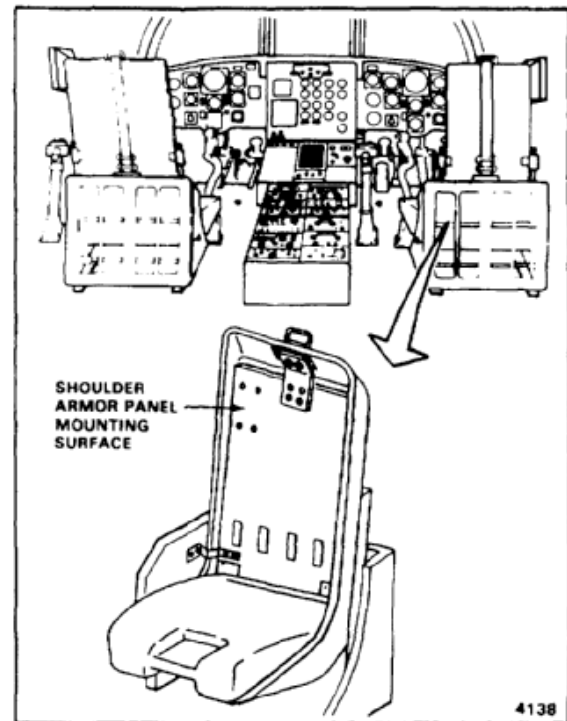
**NOTE**

Procedures are same for installing pilot's or copilot's seat armor. Pilot's seat shown here.

1. Install mounting plate assembly (1) on back armor panel (2). Install four screws (3) and washers (4).
2. Remove hinge (5) from hinge halves (6 and 7) on mounting plate assembly (1).
3. Place spacer (8) on shoulder armor panel (9). Leave top insert (10) unused.

**NOTE**

Pilot's seat hinge has four screws.  
Copilot's seat hinge has three screws.

4. Install hinge half (6) over spacer (8). Use screws (11).
5. Align hinge halves (6 and 7). Install hinge pin (5).

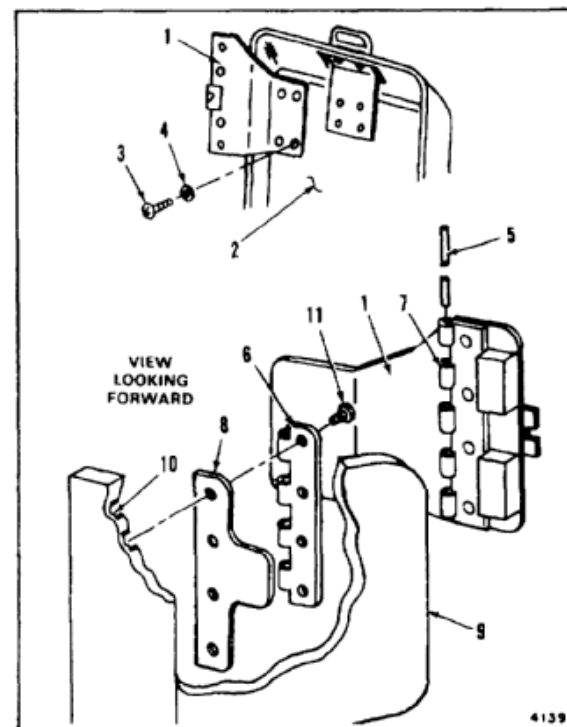

6. Rotate shoulder armor panel (9) forward until spring latch (12) engages striker plate (13). If needed, bend spring latch slightly.
7. Hook rings of each end of exerciser cord (14) to eyebolts (15) on mounting plate assembly (16).

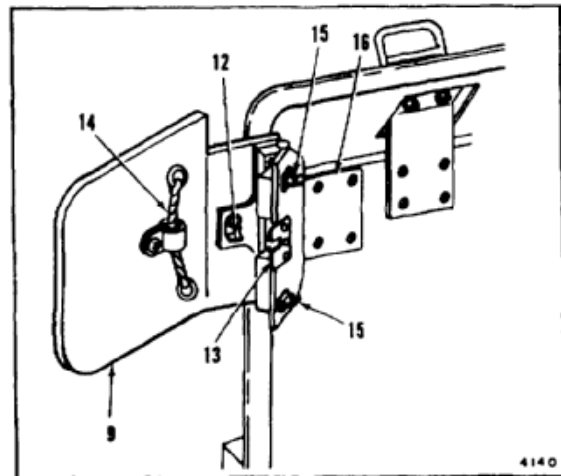

8. Position back seat cushion (17) on armor panel (2).
9. Snap four fasteners (18) to back of seat bucket (19). Press against cushion (17) so that hook tape (20) sticks to pile tape (21).

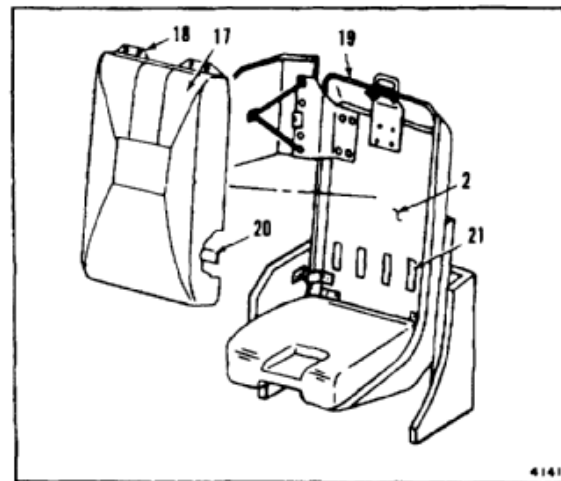
**FOLLOW-ON MAINTENANCE:**

None

END OF TASK

16-300

## INITIAL SETUP

**Applicable Configurations:**With **7****Tools:**

None

**Materials:**

None

**Personnel Required:**

Medium Helicopter Repairer

**Equipment Condition:**

Off Helicopter Task

**NOTE**

Procedure is same to inspect pilot's or copilot's armor. Pilot's armor shown here.

Armor must be removed from seat for complete inspection.

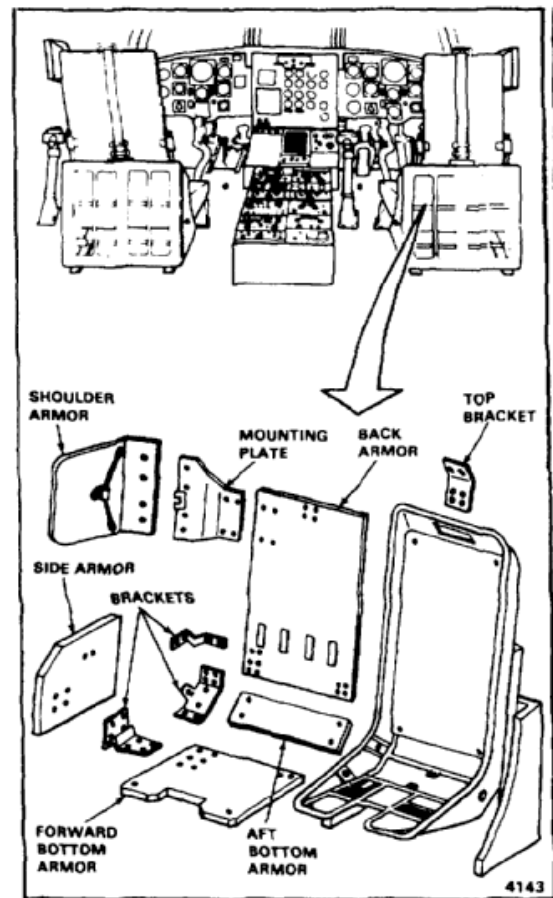

1. Inspect armor for cracks and chips. There shall be no cracks or chips.
2. Inspect inserts (1) for looseness and damaged thread. There shall be no loose or damaged inserts.
3. Inspect brackets (2) for distortion. There shall be no distortion.
4. Inspect panels (3) for loose nylon cloth covering. There shall be no loose cloth.
5. Inspect back panel for loose tape (4). There shall be no loose tape.

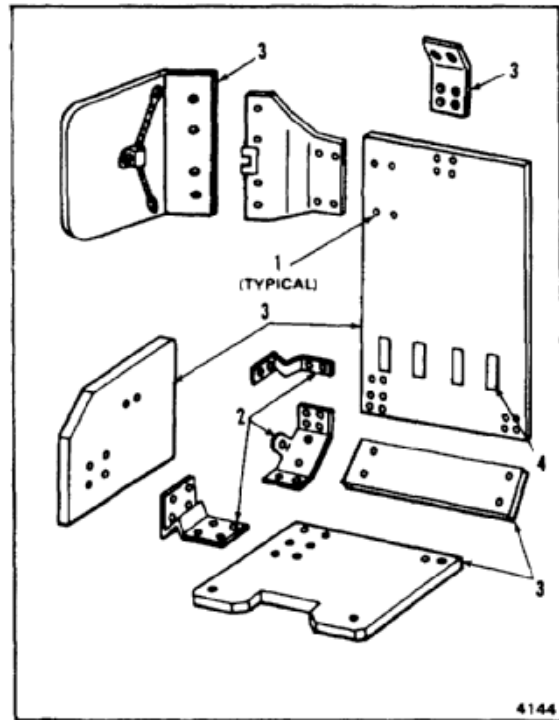
**FOLLOW-ON MAINTENANCE:**

None

END OF TASK

16-302



## INITIAL SETUP

**Applicable Configurations:**With **7****Tools:**

None

**Materials:**

None

**Personnel Required:**

Medium Helicopter Repairer

**References:**

Task 1-36

Task 1-37

Task 1-38

**Equipment Condition:**

Battery Disconnected (Task 1-39)

Electrical Power Off

Hydraulic Power Off

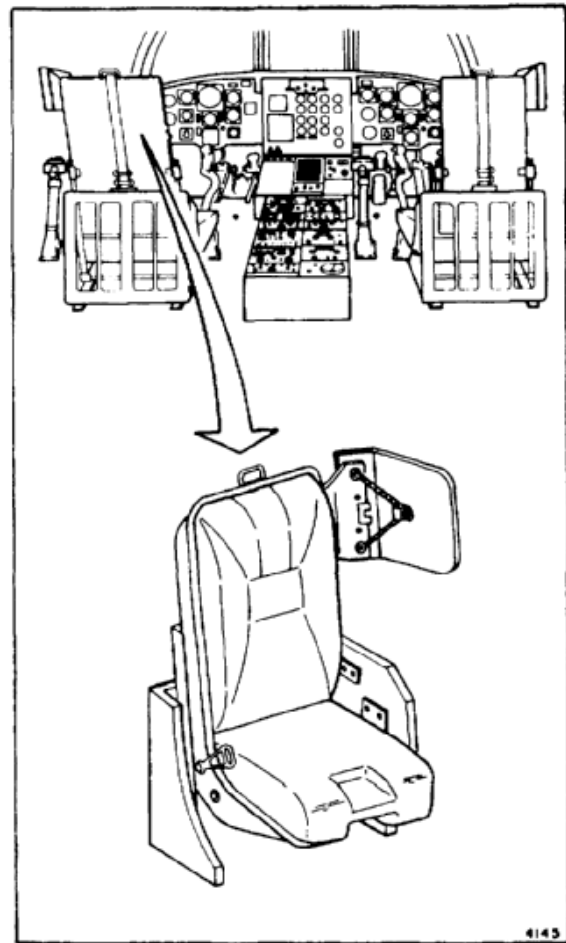
**NOTE**

Procedure is same for checking pilot's or copilot's seat armor, except as noted. Copilot's seat shown here.

1. Operate seat fully up and aft.
2. Slowly move seat fully forward. As seat moves, check that side armor panel (1) and shoulder armor panel (2) clear helicopter structure by at least **0.25 inch**.
3. If there is not enough clearance at side armor panel (1), adjust panel at slotted holes in brackets (3 and 4). As an alternate, bend brackets.
4. If there is not enough clearance at shoulder armor panel (2), bend mounting plate (5).

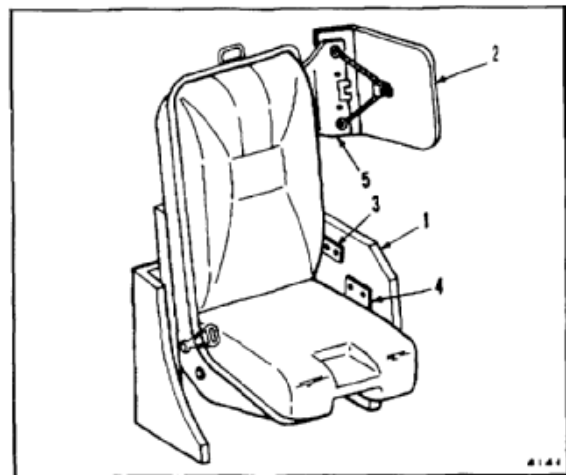

**NOTE**

Steps 5 thru 8 apply to copilot's seat only.

5. Apply electrical and hydraulic power to the helicopter (Task 1-36 or 1-37 and 1-39).
6. Check that seat is fully up and forward.

**CAUTION**

Before moving thrust control, check for obstructions near blades. As controls are moved, blades can swing through lead-lag range. Blade damage can result if blades strike an obstruction.

7. Slowly pull thrust control (6) fully up. Check that side armor panel (1) clears thrust control by at least **0.25 inch**. If not, adjust panel as in step 3.
8. Remove electrical and hydraulic power from helicopter (Task 1-36 or 1-37 and 1-38).
9. Operate seat fully down.
10. Slowly move seat fully aft. As seat moves, check that panels (1 and 2) clear helicopter structure by at least **0.25 inch**. If not, adjust panels as in steps 3 and 4.

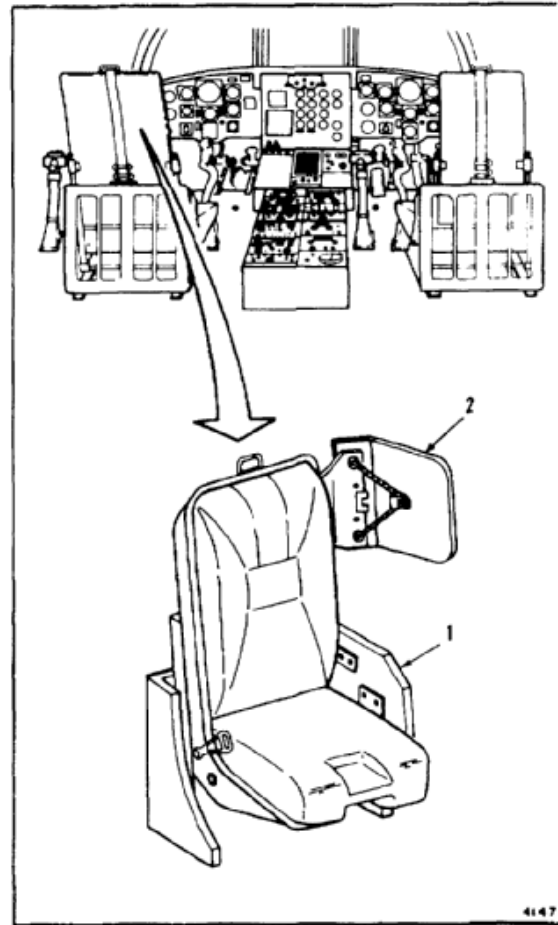
**FOLLOW-ON MAINTENANCE:**

None

END OF TASK

**SECTION XI**  
**SKI PROVISIONS DESCRIPTION**

Skis are installed on forward and aft landing gears to prevent the helicopter from bogging down in snow after landing. They are made of fiberglass and the bottoms are finish coated with epoxy coating 462, graphite filled, cured and treated with silicone and paraffin wax to prevent freezing or sticking to snow.

Skis are designed for temporary installation. Installation and removal of skis requires removal of very few permanent parts.

The forward skis are 46 inches wide and 136.75 inches long. The aft skis are 33 inches wide and 114.5 inches long.

Installation and operation of all four skis is similar. The helicopter can be towed in place over the skis, or it can be jacked and the skis placed under the landing gear. In both procedures, the tires are placed into cutouts in the skis. Each ski is supported on the landing gear by a spring-mounted swivel tail wheel, a spring cylinder, and axles. Ski axles on both sides screw into the landing gear axle stubs. Horizontal balance of the ski is maintained by a safety cable and shock ring assembly, a check cable, and the spring cylinder.

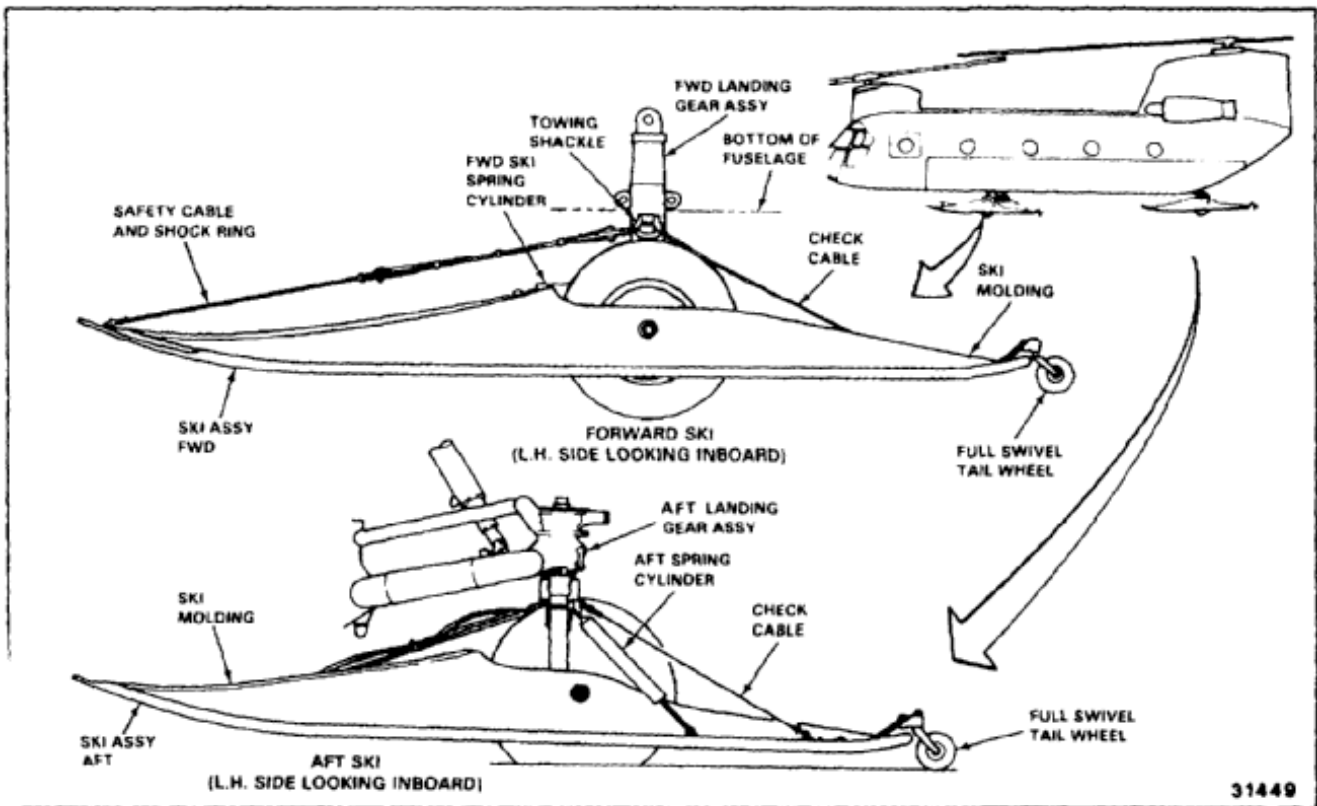

END OF TASK

**SECTION XII**  
**SKI PROVISIONS**

INITIAL SETUP

**Applicable Configurations:**

All

**Tools:**

Aircraft Mechanic's Tool Kit, NSN 5180-00-323-4692  
 Adapter Set Arctic Tow Bar, NSN 1730-00-168-5439

**Materials:**

None

**Personnel Required:**

Medium Helicopter Repairer (3)

**References:**

Task 1-20  
 Task 1-21  
 Task 1-71

**Equipment Condition:**

Battery Disconnected (Task 1-39)  
 Helicopter on Hard Level Surface  
 Helicopter Roped Off  
 Signs Posted to Restrict Access

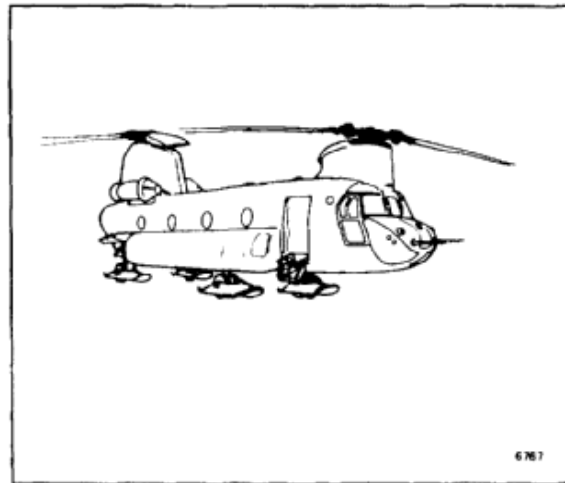

**NOTE**

Remove skis by jacking or towing.  
 Both methods are shown here.

**TOWING METHOD**

**NOTE**

Procedure for removing right and left aft skis is same. Removal of left ski is shown here.

1. Remove cotter pin (1), clevis pin (2), and check cable (3) from bracket (4).
2. Remove cotter pin (5) from bolt (6). Remove nut (7), washer (8), cylinder (9), and bolt (6) from bracket (4).
3. Remove nut (10), washer (11), shock-ring (12), and bolt (13) from eyebolt (14).

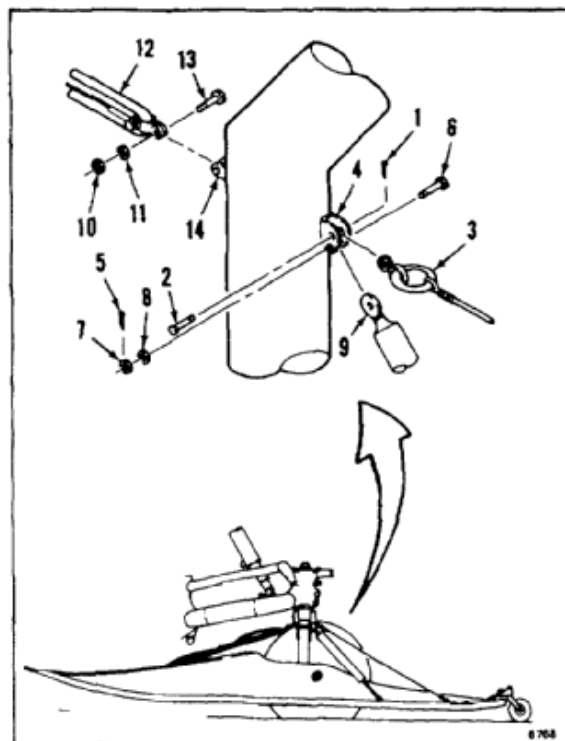

4. Remove nut (15), washer (16), and eyebolt (14) from aft landing gear (17).
5. Remove bracket (4) from landing gear (17).
6. Install bolt (18) in landing gear (17).

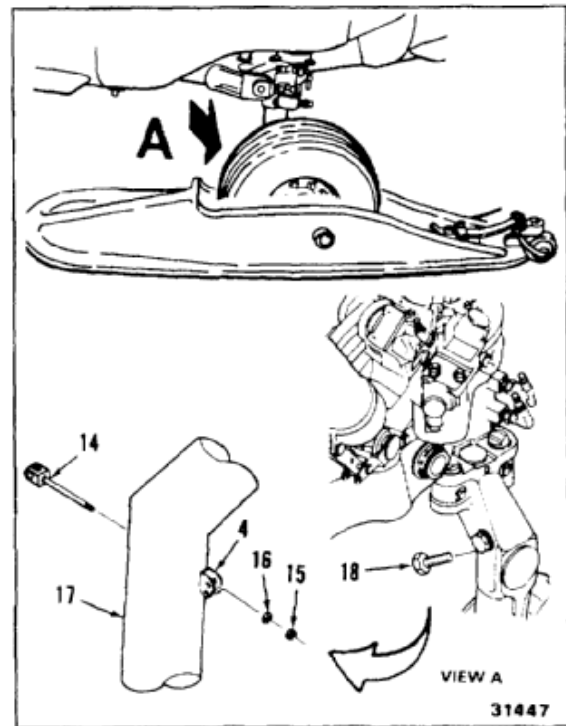

7. Remove cotter pins (19) from bolt (20).
8. Remove nut (21), washer (22), cylinder (9), and bolt (20) from bracket (23).
9. Remove cotter pin (26) from bushings (27) and axles (28).
10. With the aid of helper, unscrew axles (28) from axle stubs (29).
11. With the aid of helper, remove thrust washers (30) and bearings (31).

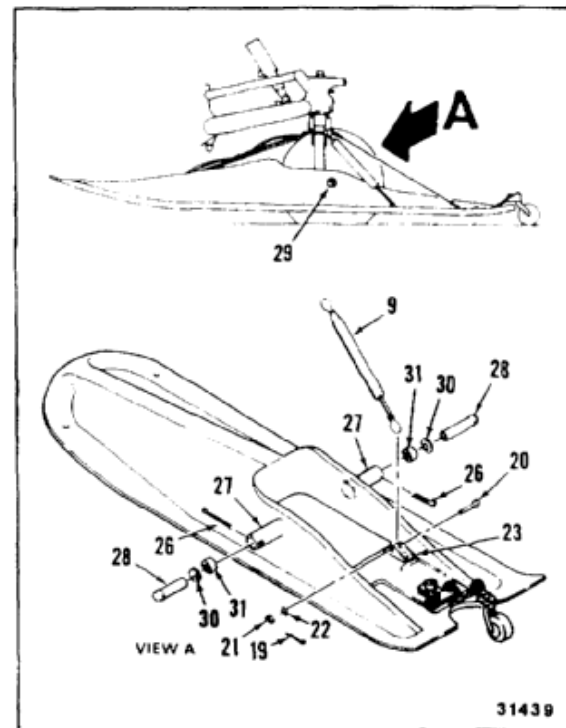

12. With aid of helper, lower aft ski (30) to ground.
13. Remove bolts (41), tabs (42), and nuts (43) from ski (30).
14. Remove nut (44), tab (34), check cable (3), tail wheel assembly (36), and bolt (45) from ski (30).
15. Remove nuts (46), bracket (23), and bolts (47) from ski (30).

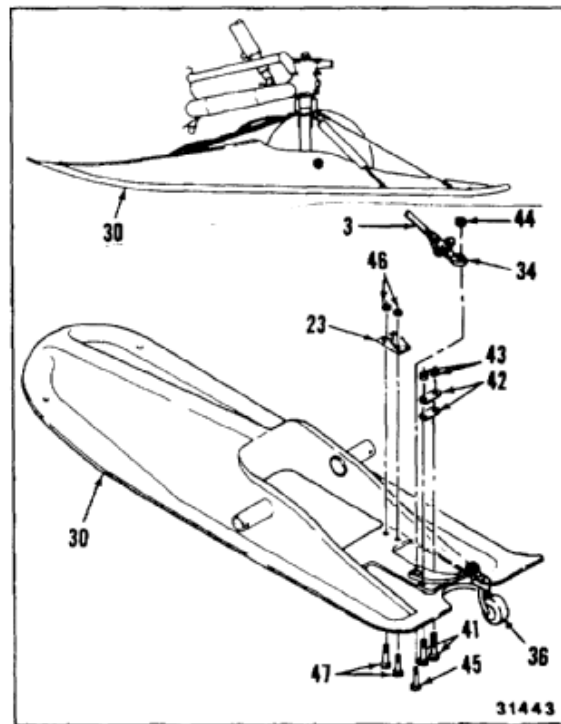

16. Remove nut (48), washer (49), safety cable, and shock ring (12), and bolt (50) from ski (30).

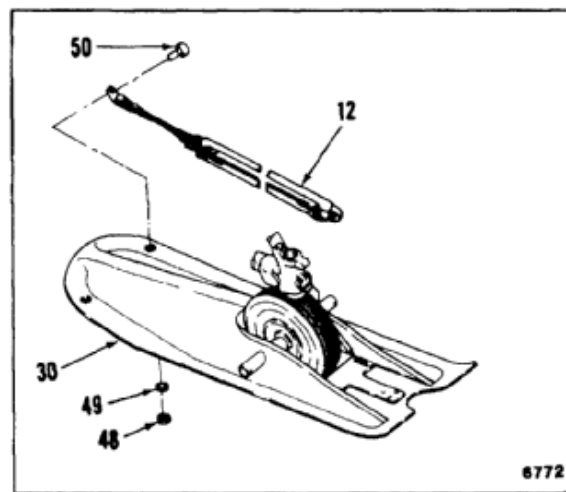



**NOTE**

Procedure for removing right and left forward skis is same. Removal of left forward ski is shown here.

17. Remove nut (51), two washers (52), spring cylinder (53), and bolt (54) from swivel fitting (55).
18. Inflate forward landing gear (56) high enough for upper scissor point (57) to clear top of tires (58) (Task 1-71).
19. Remove nut (59), two washers (60), fitting (55), and bolt (61) from upper scissor point (57).
20. Remove two end fittings (62) from upper scissor point (57).

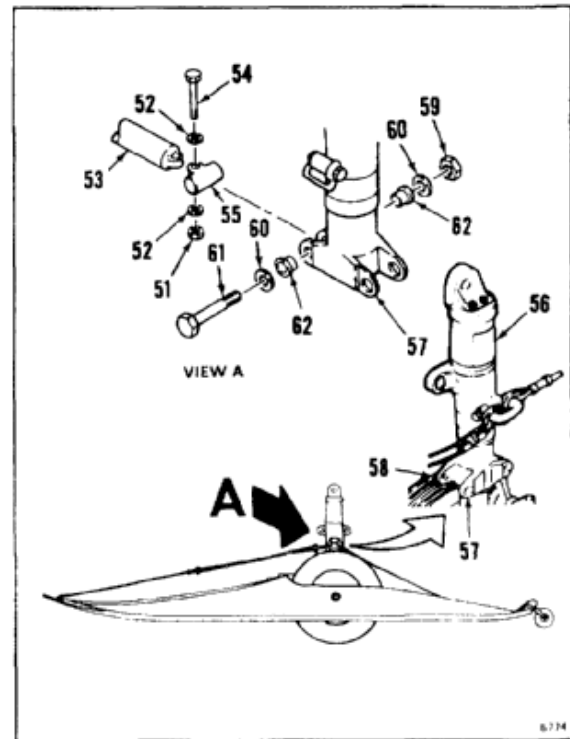

21. Remove cotter pin (63) from bolt (64). Remove nut (65), washer (66), towing shackle (67), and bolt (64) from landing gear (56).
22. Remove slip-ring (68) of safety cable (69), and ring (70) of check cable (71) from towing shackle (67).
23. Remove anti-chafing rubber pad (72) and straps (73) from landing gear (56).
24. Position towing-shackle (67) on landing gear (56).
25. Install bolt (64), washer (66), nut (65), and cotter pin (63).

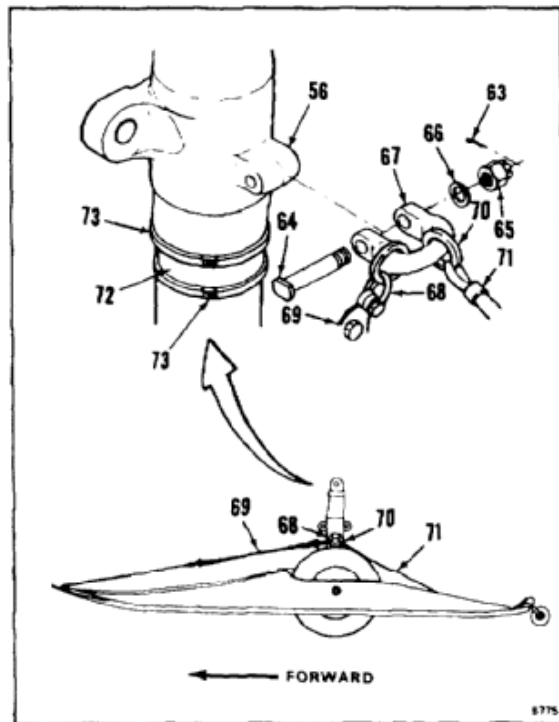

26. Remove cotter pin (76) from bushings (77) and ski axles (78).
27. With the aid of helper, unscrew axles (78) from bushings (77) and landing gear axle stubs (79).
28. With the aid of helper, remove thrust washers (81) and bearings (82).
29. With the aid of helper, lower forward ski (80) to ground.

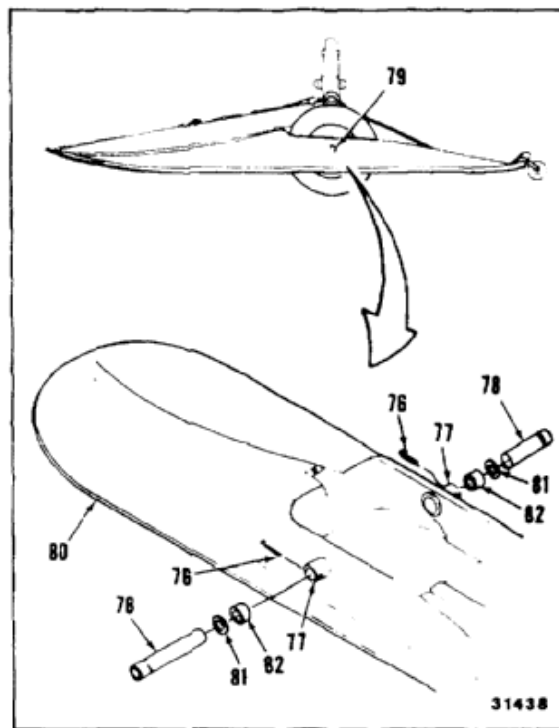

**16-85 SKI REMOVAL (Continued)**

- 30. Remove nut (81), washer (82), check cable (71), and bolt (83) from tab (84).
- 31. Remove nut (85), tail wheel (86), spacer (87), washer (88), and bolt (89) from two leaf springs (90).
- 32. Remove nuts (91), two tabs (92), and two bolts (93) from ski (80).
- 33. Remove nut (94), tab (84), leaf springs (90), and bolt (95) from ski (80).

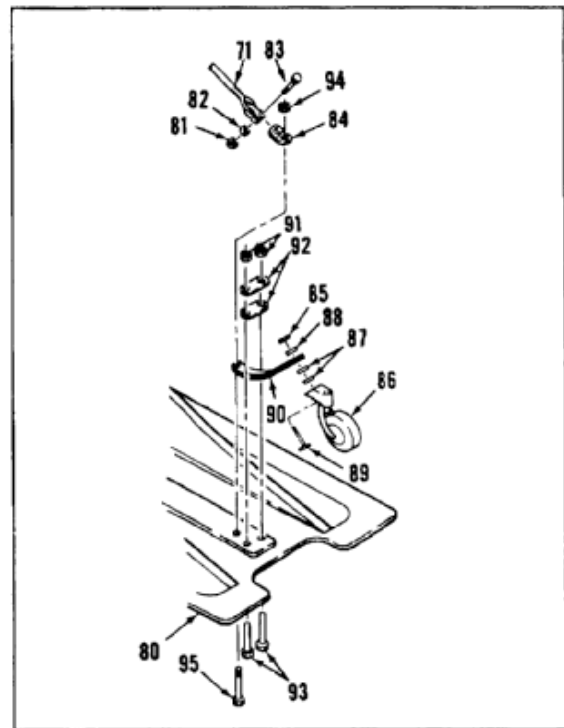

- 34. Remove nut (96), bushing (97), spring cylinder (56), and bolt (98) from eyebolt (99).
- 35. Remove eyebolt (99) from ski (80).
- 36. Remove nut (100), washer (101), safety cable (69), and bolt (102) from ski (80).

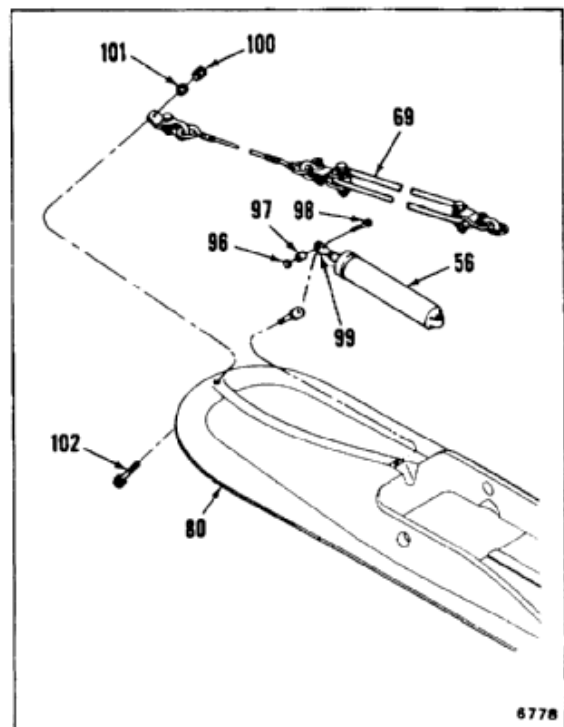

6778

- 37. Tow helicopter (103) backwards off skis (80 and 30). Refer to alternate towing (Task 1-20).

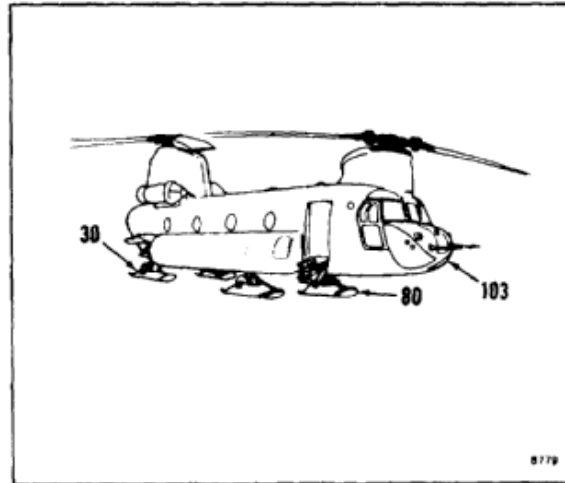

- 38. Remove two bushings (104) from forward ski (80).
- 39. Remove ski (80).

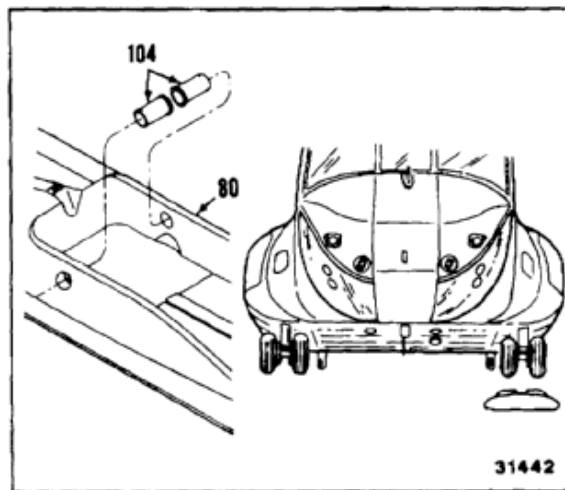

- 40. Remove two bushings (105) from aft ski (30).
- 41. Remove ski (30).

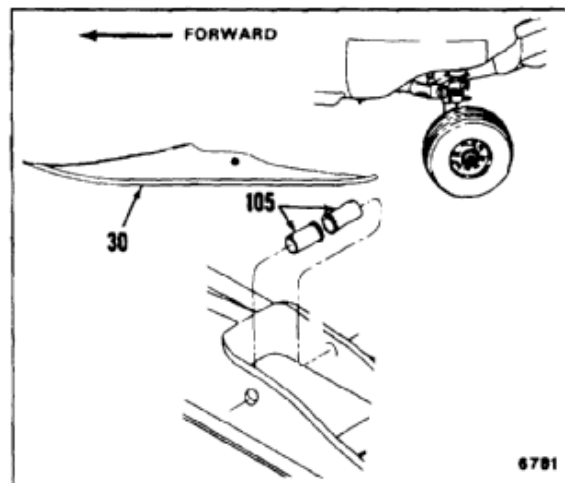

**JACKING METHOD****NOTE**

Procedure for removing skis by jacking method is same for towing method in steps 1 thru 36.

42. Perform steps 1 thru 36.
43. Turn aft landing gear (17) **90°** outward.

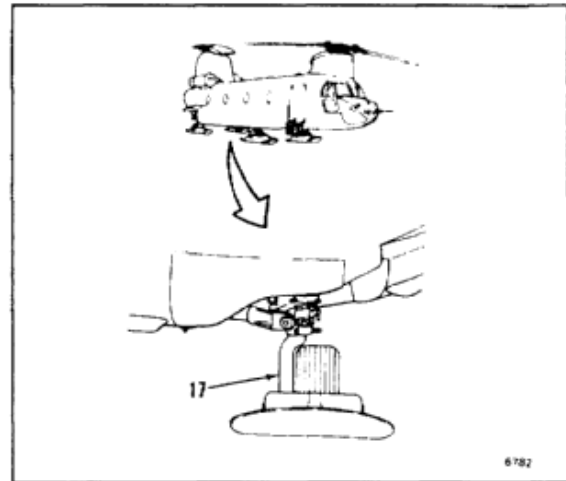

44. Jack helicopter (103) (Task 1-21).
45. Perform step 38.
46. Lower helicopter (103).

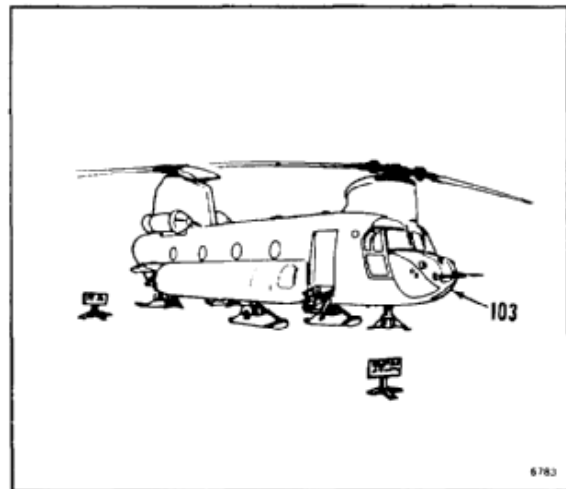
**FOLLOW-ON MAINTENANCE:**

Install retaining ring and sleeves (Task 3-12).  
Remove signs and ropes restricting access.

END OF TASK

## INITIAL SETUP

**Applicable Configurations:**

All

**Tools:**

Aircraft Mechanic's Tool Kit, NSN 5180-00-323-4692

**Materials:**

Lubriplate (E240)

**Personnel Required:**

Medium Helicopter Repairer (3)

**References:**

Task 1-20

Task 1-21

Task 1-71

**Equipment Condition:**

Battery Disconnected (Task 1-39)

Helicopter on Hard Level Surface

Helicopter Roped Off

Signs Posted to Restrict Access

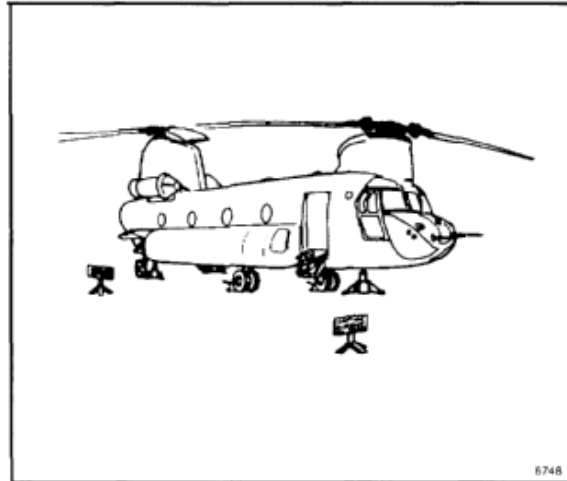
Lockrings and Sleeves on Landing Gear Axles  
Removed (Task 3-7)**NOTE**

Install skis by jacking or by towing helicopter. Both methods are shown here.

If towing method is used, go to step 36.

**JACKING METHOD****NOTE**

Procedure for preparing right and left forward and aft skis for installation is same. Preparation of left forward and left aft ski is shown here.

1. Prepare forward ski (1) for installation by doing the following:
  - a. Install bolt (2), safety cable (3), washer (4), and nut (5) on ski (1).
  - b. Install eyebolt (6) on ski (1).
  - c. Install bolt (7), spring cylinder (8), bushing (9), and nut (10) in eyebolt (6).
  - d. Check that two bushings (11) in ski (1) are clean and free of obstructions.
  - e. Install bolt (12), two leaf springs (13), tab (14), and nut (15) on ski (1).
  - f. Install two bolts (16), tabs (17), and nuts (18) on ski (1).
  - g. Install bolt (19), tail wheel (20), spacer (21), washer (22), and nut (23) on springs (13).
  - h. Install bolt (24), check cable (25), washer (26), and nut (27) on tab (14).

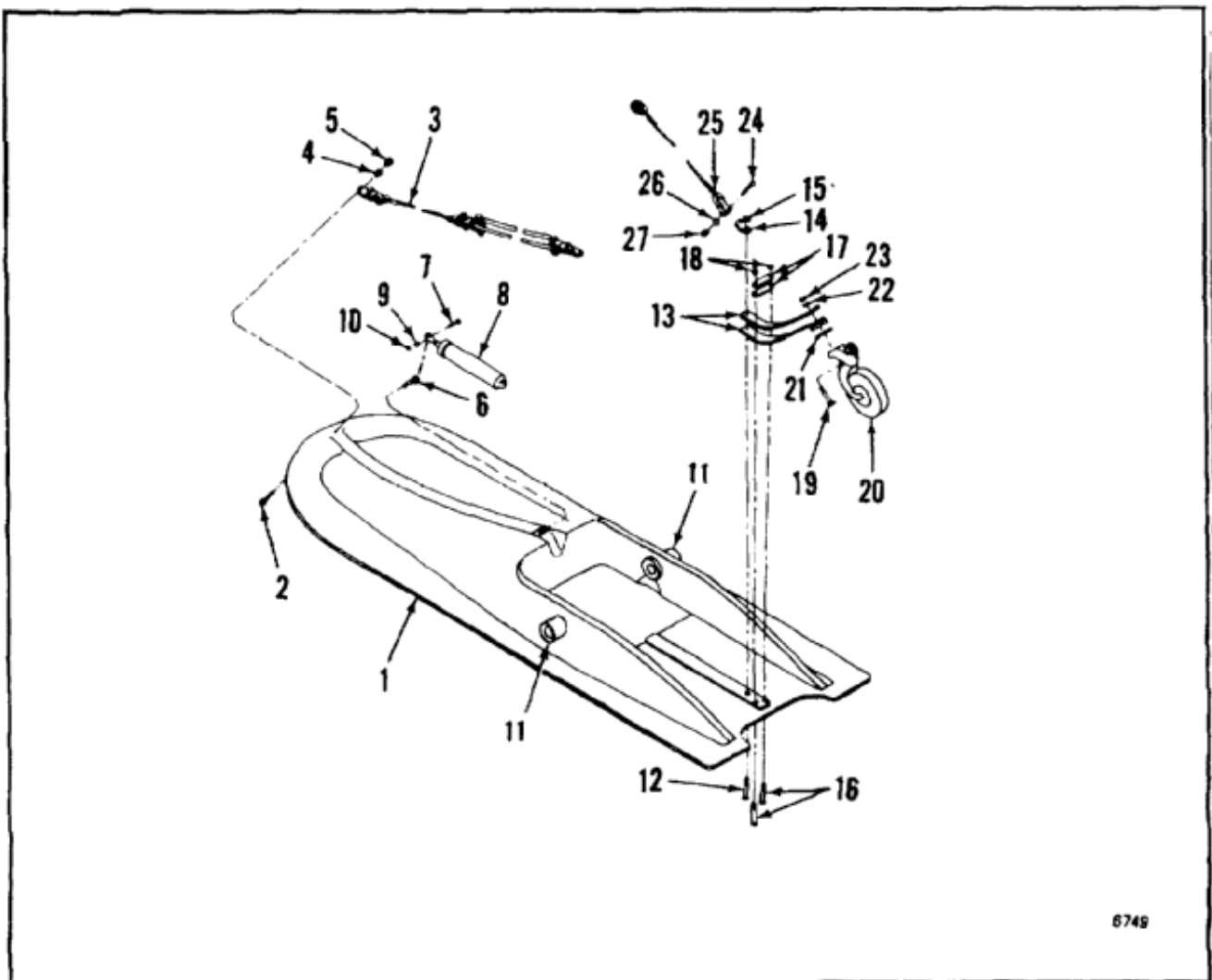

6749

2. Prepare aft ski (28) for installation by doing the following:
  - a. Install bolt (29), safety cable and shock ring (30), washer (31), and nut (32) on ski (28).
  - b. Check that bushings (33) are clean and free of obstructions.

**NOTE**

For installation of right ski, cylinder bracket is installed on inboard side of ski.

- c. Install bolts (34), cylinder bracket (35), and nuts (36) on ski (28).
- d. Install bolts (37), tabs (38), and nuts (39) on ski (28).
- e. Install bolt (40), leaf springs (41), tab (42), and nut (43) on ski (28).
- f. Install bolt (44), tail wheel (45), spacers (46), washer (47), and nut (48) on leaf springs (41).
- g. Install bolt (49), check cable (50), washer (51), and nut (52) on tab (43).

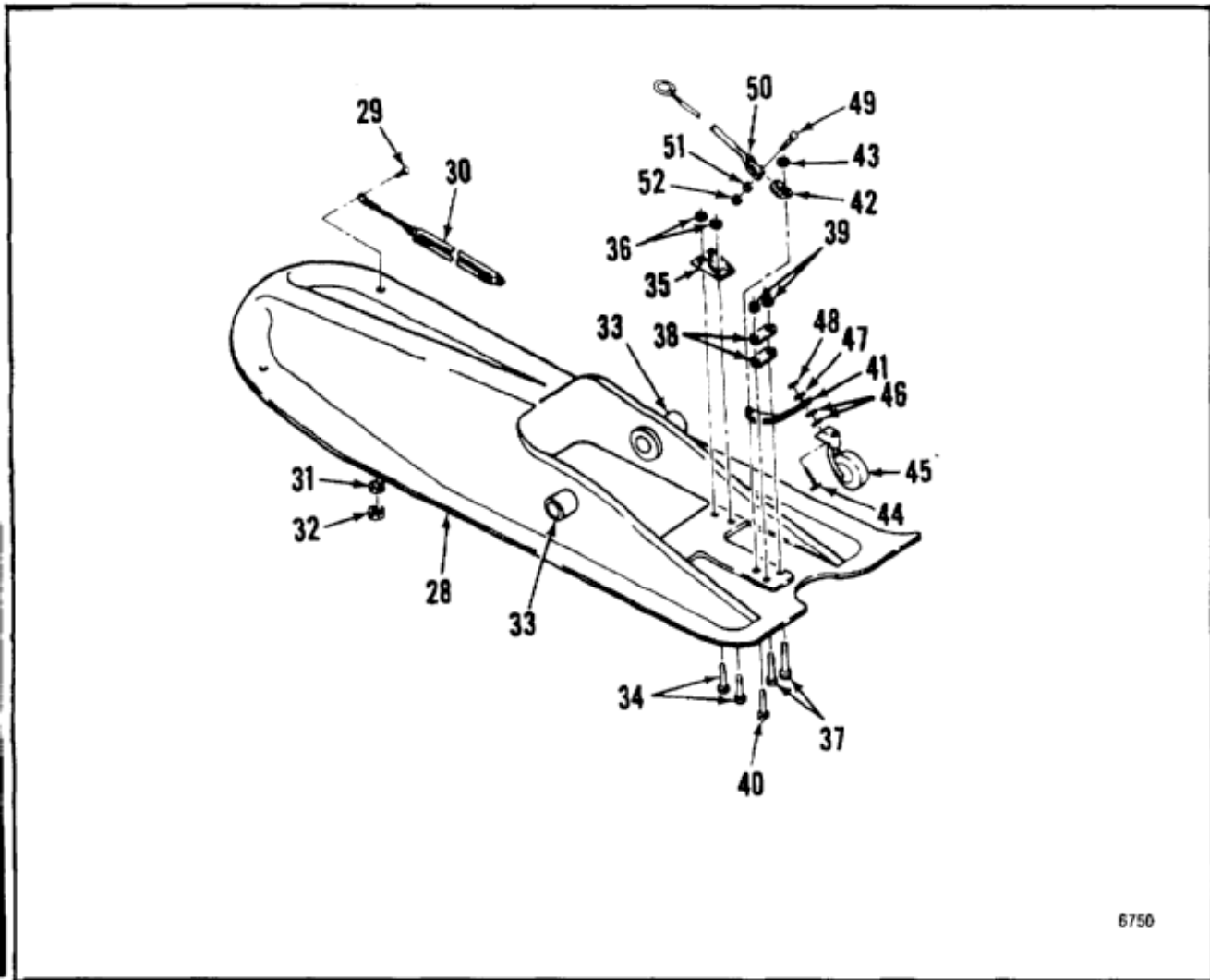

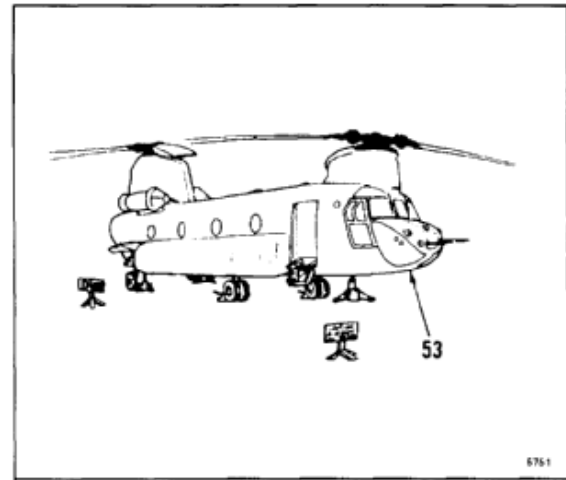

3. Jack entire helicopter (53) (Task 1-21).

**NOTE**

Procedure for installing skis on right and left forward landing gears is same. Left forward landing gear installation is shown here.

4. Slide ski (1) into position under tires (54) on left forward landing gear (55).

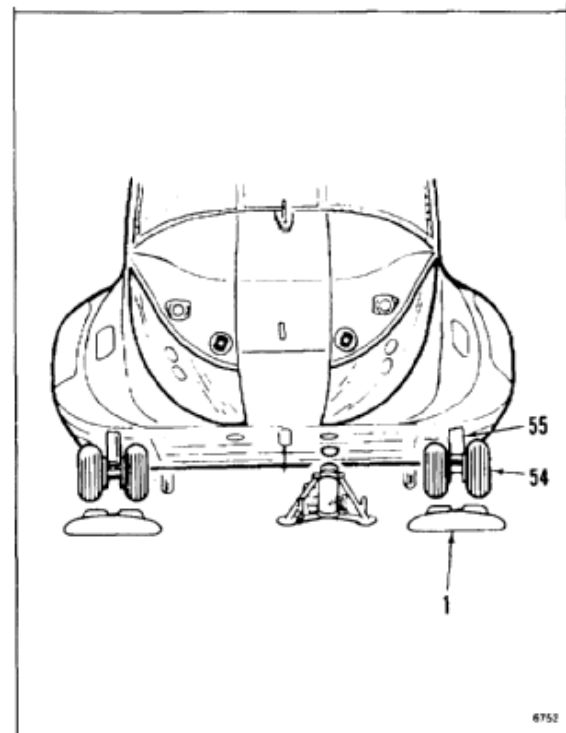

**NOTE**

Procedure for installing skis on right and left aft landing gear is same. Left aft landing gear installation is shown here.

5. Turn left aft landing gear (56) **90°** outboard.
6. Slide ski (28) into position under tires (57).

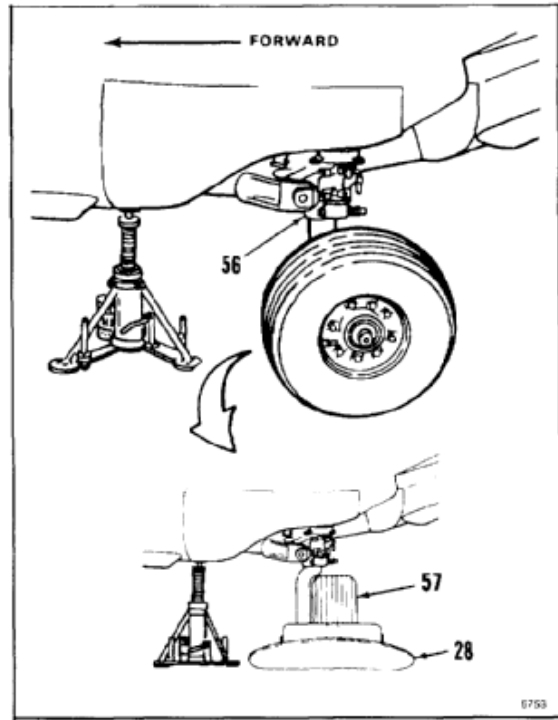

7. Lower helicopter (53) (Task 1-21).



8. Inflate forward landing gear (55) high enough for upper scissor point (58) to clear top of tires (54).

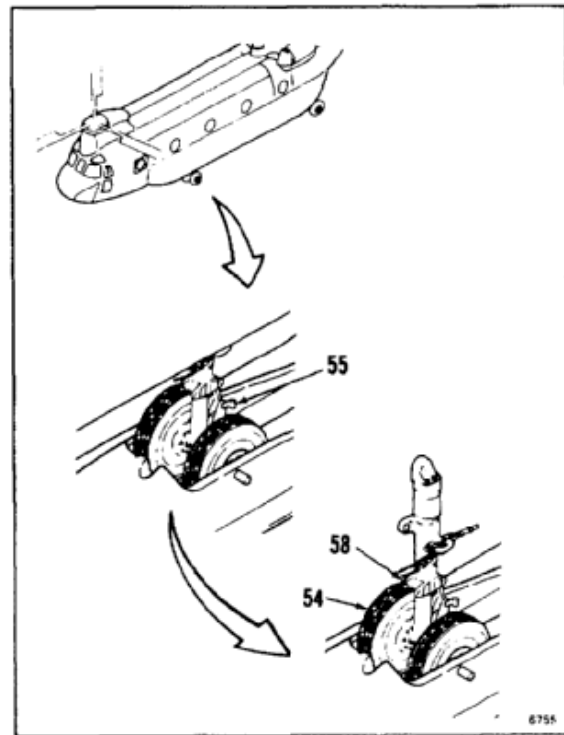

9. Apply a thin film of lubriplate (E240) to axles (59) of forward ski (1).
10. With the aid of helper, lift ski (1) into position on forward landing gear (55).
11. Install bearings (63), thrust washers (64), and axles (59) in bushings (11).
12. Screw axles (59) into bushings (11) and axle stubs (60) of forward landing gear (55) as far as possible.
13. Unscrew axles (59) enough to align cotter pin holes in axle with cotter pin holes in bushings (11).
14. Install cotter pin (61) in bushings (11) and axles (59).

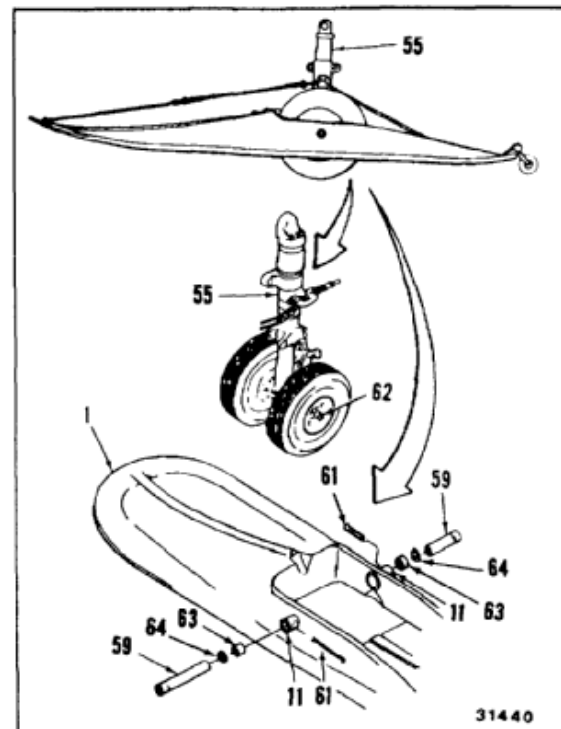

15. Position spring cylinder (8) on swivel fitting (64). Install bolt (65), two washers (66), and nut (67) on swivel fitting.
16. Install two end fittings (68) on landing gear (55) at upper scissor point (58).
17. Spring tension on cylinder (8) may be too strong to install cylinder and fitting (68) on landing gear (55). If so, remove lower end of cylinder (8), bolt (7), bushing (9), and nut (10) from eyebolt (6).
18. Position swivel fitting (64) on forward landing gear (55) at upper scissor point (58). Install bolt (69), two washers (70), and nut (71).

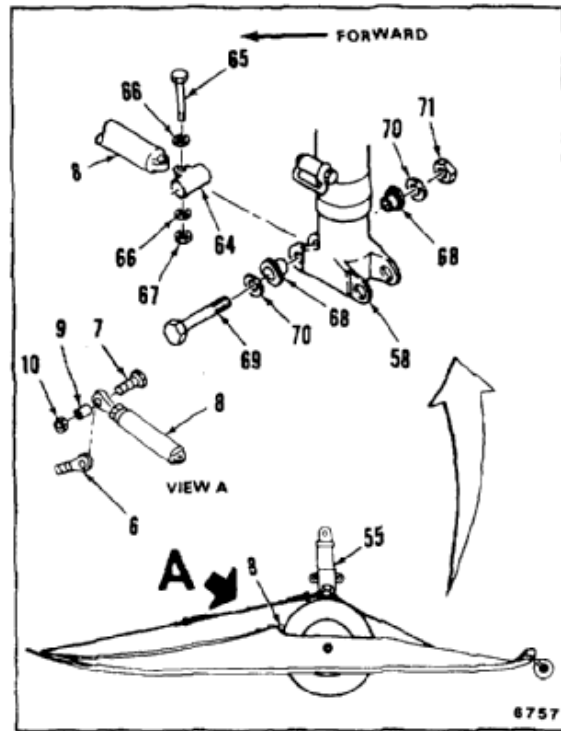

19. Remove cotter pin (72), nut (73), washer (74), towing shackle (75), and bolt (76) from forward landing gear (55).
20. Slip ring (77) of safety cable (3), and ring (78) of check cable (25) on shackle (75).
21. Install shackle (75), bolt (76), washer (74), and nut (73) on landing gear (55). Install cotter pin (72) in nut (73).

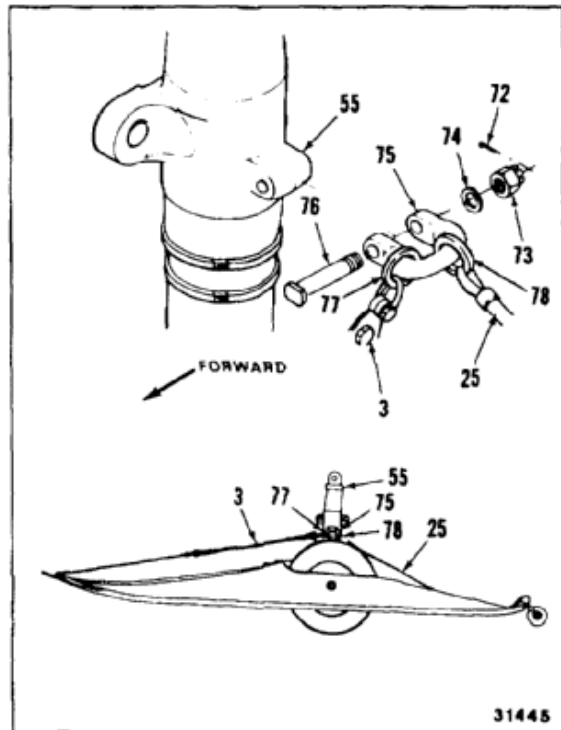

22. Install anti-chafing rubber pad (79) and straps (80) on landing gear (55).
23. If lower end of spring cylinder was removed in step 17, Task 16-85, reinstall cylinder (step 1c).

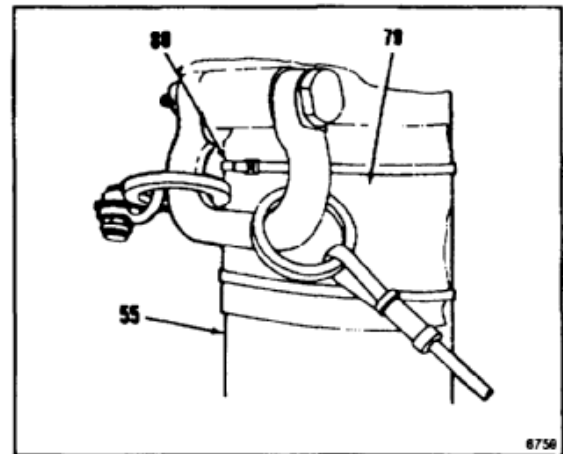

24. Remove bolt (81) from aft landing gear (56).
25. Install eyebolt (82), spring cylinder mounting bracket (83), washer (84), nut (85), and cotter pin (104) on landing gear (56).

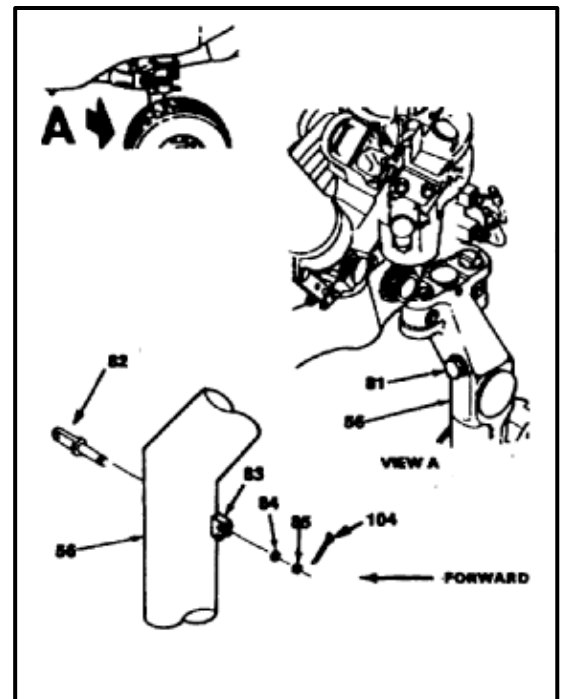

26. Apply thin film of lubriplate (E240) to axles (86) of aft ski (28).
27. With aid of helper, lift ski (28) into position on aft landing gear (50).
28. Install bearings (89), thrust washers (90), and axles (88) in bushings (33).
29. Screw axles (88) into bushings (33) and axle stubs (87) of aft landing gear (58) as far as possible.
30. Unscrew axles (88) enough to align cotter pin holes in axle with cotter pin holes in bushings (33).
31. Install cotter pin (88) in bushings (33) and axles (88).

**NOTE**

Lower spring mounting bracket must be installed on inboard side of ski.

32. Install lower end of cylinder (91), bolt (92), washer (93), and nut (94) on bracket (35). Install cotter pin (95) in bolt (92).

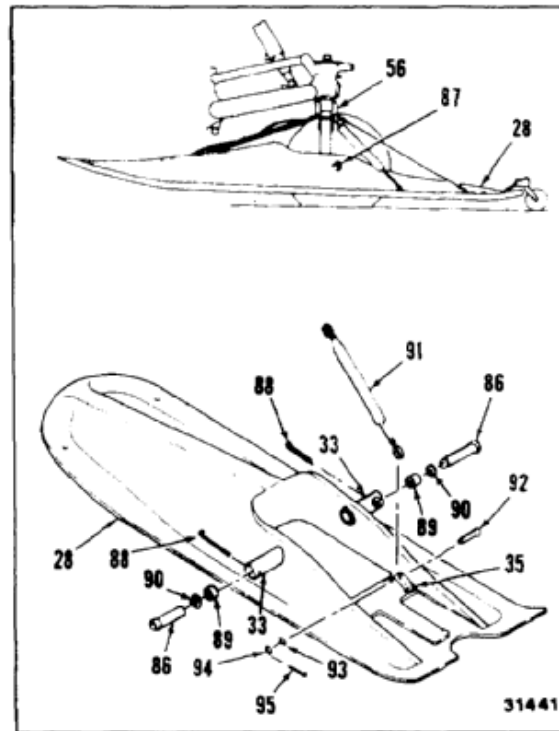

33. Install safety cable and shock ring (30), bolt (90), washer (97), and nut (98) on eyebolt (82). Stretch the shock ring if necessary.
34. Install top of cylinder (91), bolt (99), washer (100), and nut (101) on bracket (83). Install cotter pin (102) in bolt (99).
35. Install check cable (50), clevis bolt (103), and cotter pin (104) on inboard lug of bracket (83).

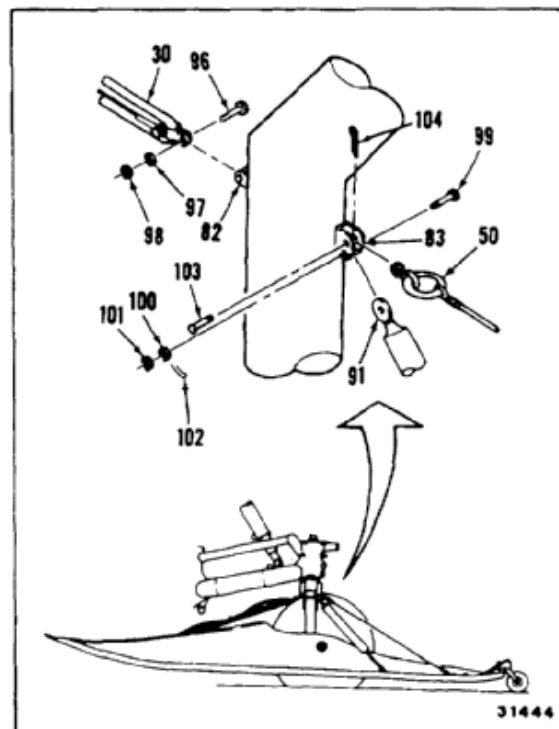

**TOWING METHOD**

**NOTE**

Procedure for installing right and left forward skis is same. Installation of left front ski is shown here.

- 36. Position forward ski (1) under helicopter (53), in front of forward landing gear (55).

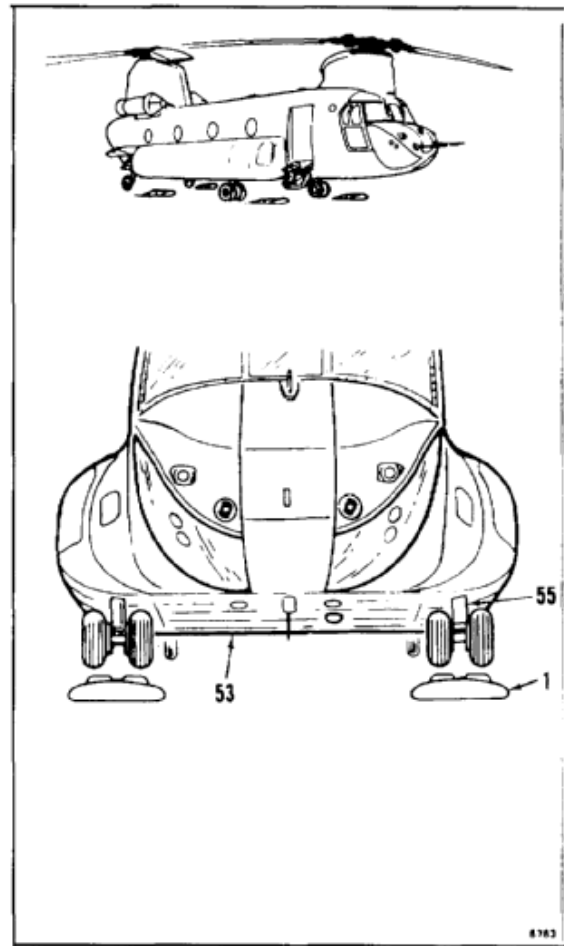

**NOTE**

Procedure for installing right and left aft skis is same. Installation of left aft ski is shown here.

- 37. Position aft ski (28) under helicopter (53) in front of aft landing gear (56).

**NOTE**

Ensure aft swivel wheels on forward and aft skis have been removed.

- 38. Tow helicopter (53) in position on skis (1 and 28). Refer to alternate towing (Task 1-20).

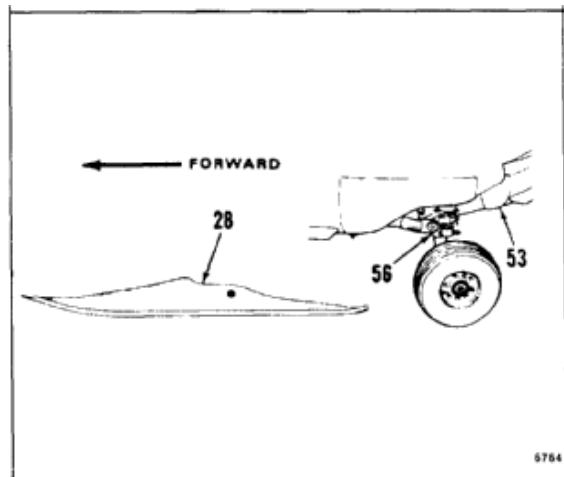

39. Prepare forward ski (1) for installation by doing the following:
- Install bolt (2), safety cable (3), washer (4), and nut (5) on ski (1).
  - Install eyebolt (6) on ski (1).
  - Install bolt (7), spring cylinder (8), bushing (9), and nut (10) on eyebolt (6).
  - Install bolt (12), two leaf springs (13), tab (14), and nut (15) on ski (1).
  - Install two bolts (16), two tabs (17), and nuts (18) on ski (1).
  - Install bolt (19), tail wheel (20), spacer (21), washer (22), and nut (23) on springs (13).
  - Install bolt (24), check cable (25), washer (26), and nut (27) on tab (14).

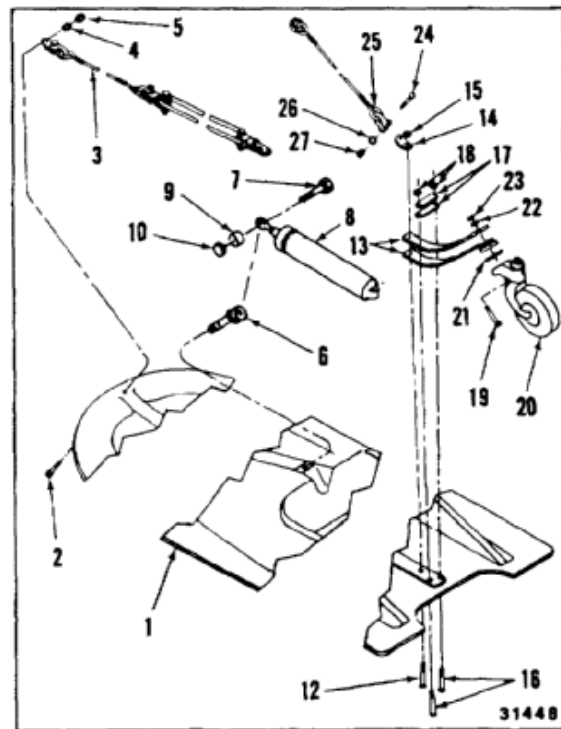

40. Prepare aft ski (28) for installation by doing the following:
- Install bolt (29), safety cable and shock ring (30), washer (31), and nut (32) on ski (28).
  - Install two bolts (34), cylinder bracket (35), and nuts (36) on ski (28).
  - Install two bolts (37), two tabs (38), and two nuts (39) on ski (28).
  - Install bolt (40), two leaf springs (41), tab (42), and nut (43) on ski (28).
  - Install bolt (44), tail wheel (45), two spacers (46), washer (47), and nut (48), on leaf springs (41).
  - Install bolt (49), check cable (50), washer (51), and nut (52) on tab (43).

**NOTE**

Complete installation by performing steps 8 thru 35.

**FOLLOW-ON MAINTENANCE:**

None

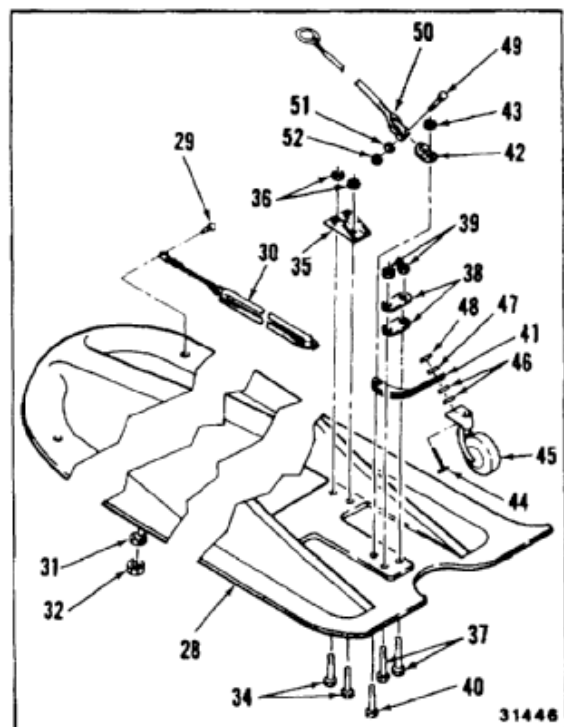

END OF TASK



**SECTION XIII**  
**HEAD UP DISPLAY DESCRIPTION AND OPERATION**

The head up display (HUD) consists of signal data converter (SDC), the converter control (CCU), air data transducer, inclinometer and the display unit (DU), consisting of the optical unit (OU) and power supply calibration unit (PSCU). The HUD display allows the pilots using the aviator night vision imaging system (ANVIS) during night flight operations to receive flight data about the aircraft through symbology without viewing the instrument panel. The OU is attached to the ANVIS. The HUD has two programming modes and one operational mode which allow the pilot and copilot to independently select the symbology for their respective display modes from a master set of symbols in the signal data converter. Power to operate the HUD system is taken from the **26vac** essential bus and the **28vdc**

bus through circuit breakers located on the copilots's circuit breaker panel, labeled HUD REF and HUD SYS. Pilot and copilot can independently select from four normal symbology modes and four declutter modes that can be pre-programmed. Declutter mode has four vital symbols that will always be displayed: Air speed, Altitude (MSL), Attitude (pitch and roll), and Engine Torque(s). An adjust mode, during operation, is used to calibrate the barometric altitude, pitch and roll. A switch on the collective stick allows for brightness control and selection of one of four displays. The system self test is divided into power-up or operator initialized built-in-test (BIT) and in-flight BIT. A failure of the SOC pilot's DU, or copilot's DU will illuminate the CCU FAIL light and display a FAIL message on display unit.

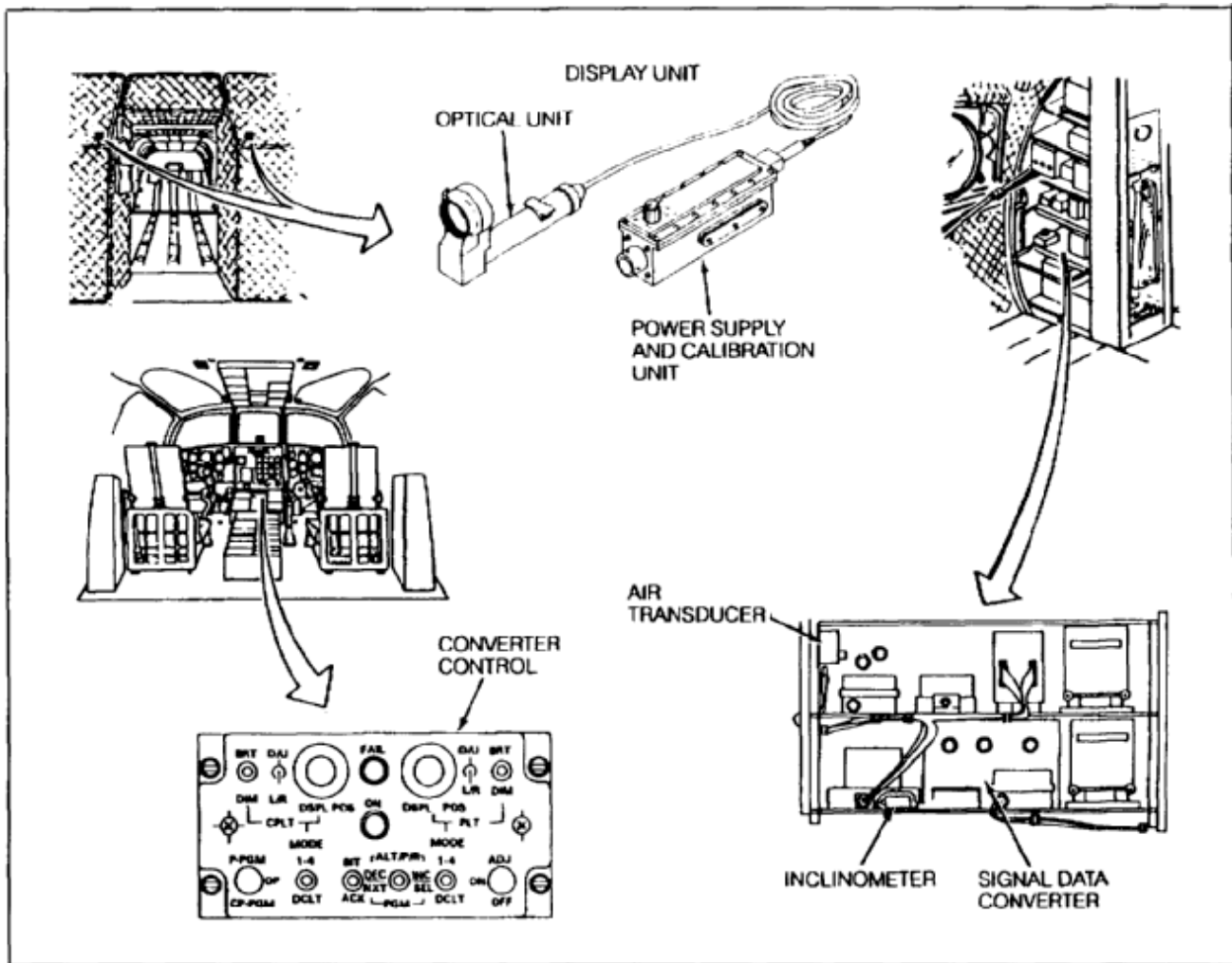



**DISPLAY UNIT (DU)**

The DU is the output interface between system and operator. The DU superimposes aircraft information and flight data onto the ANVIS image. The DU consisting of the optical unit (OU) and power supply and calibration unit (PSCU), is replaced as a complete unit. A L/R eye selector switch on the PSCU changes the scan direction for left or right eye viewing. All symbol data for the DU is generated in the SDC. Display intensity is preset to low each time the system is powered up. Connector P1 is part of the aircraft wiring and mates to J1, on the end of the PSCU. J1 is a quick-release connector for quick egress from the aircraft by the operator. The DU is calibrated during production and requires no further calibration. A focus ring on the OU is used to focus the display.

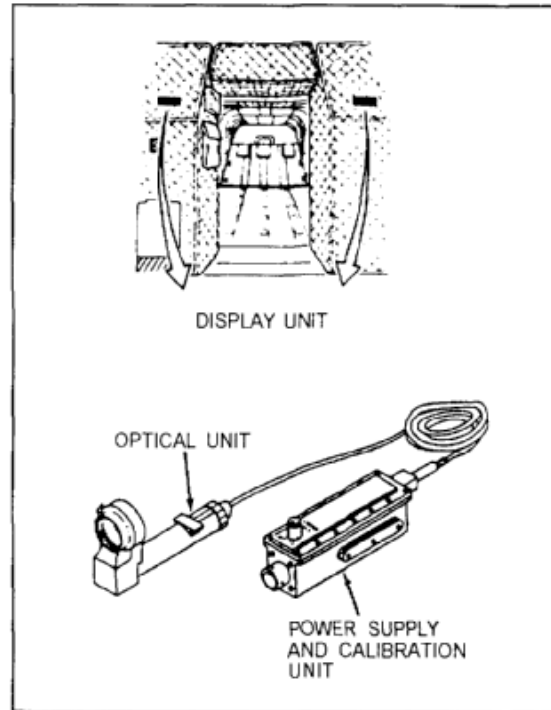

**AIR DATA TRANSDUCER**

The difference between dynamic pressure and static pressure as measured by the air data transducer provides both airspeed and barometric altitude output signals to the HUD signal data converter (SDC). These signals are processed by the SDC and applied to the HUD display unit (pilot's/copilot's). Power to operate the air data transducer is supplied by the HUD SDC.

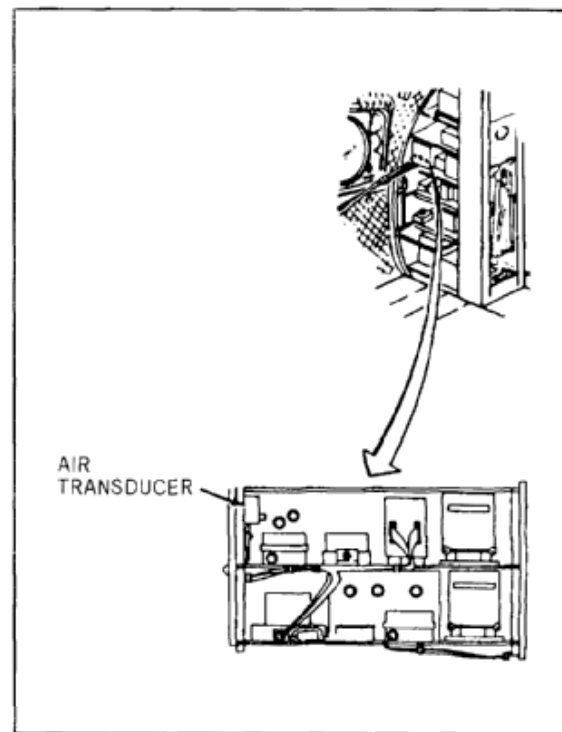

**INCLINOMETER SENSOR**

The inclinometer sensor provides an electrical input to the head up display (HUD) simulating the pilot's/copilot's slip indication (centered ball) on their respective turn and slip indicators. The electrical signal is processed by the HUD signal data converter (SDC) and applied to the pilot's/ copilot's HUD display unit (DU) as the trim symbology (centered ball  $\pm$  2 balls). Power to operate the inclinometer is supplied by the HUD SOC.

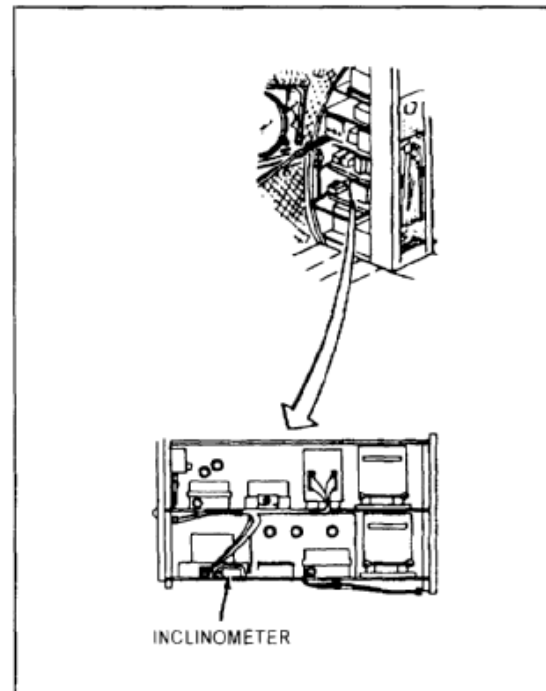

END OF TASK



**SECTION XIV**  
**HEAD UP DISPLAY**

**Applicable Configurations:**

All

**Tools:**

Aircraft Mechanic's Tool Kit, NSN 5180-00-323-4692

**Materials:**

Paper Tags (E264)

**Personnel Required:**

Medium Helicopter Repairer

**Equipment Condition:**

Battery Disconnected (Task 1-39)

Electrical Power Off

Electronic Compartment Acoustic Blanket Removed  
(Task 2-107)

Vertical Gyro Removed (TM 11-1520-240-20)

Battery Unit Removed (TM 11-1520-240-20)

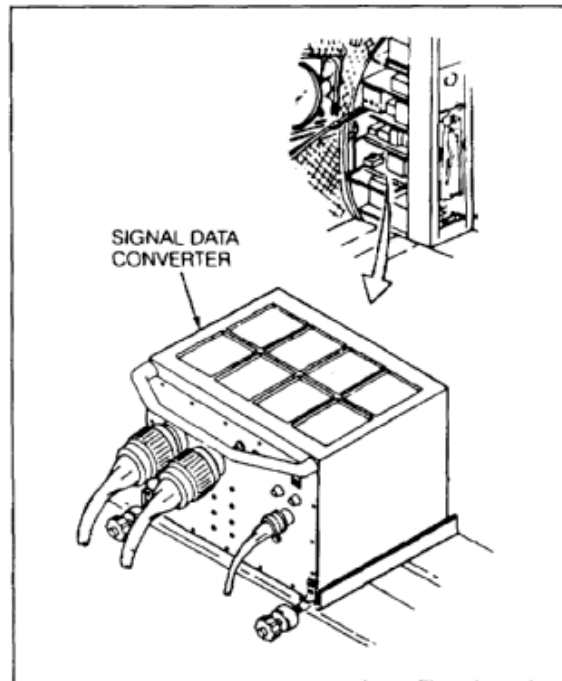

1. Tag (E264) and disconnect three connectors (1, 2, and 3) from signal data converter (4).

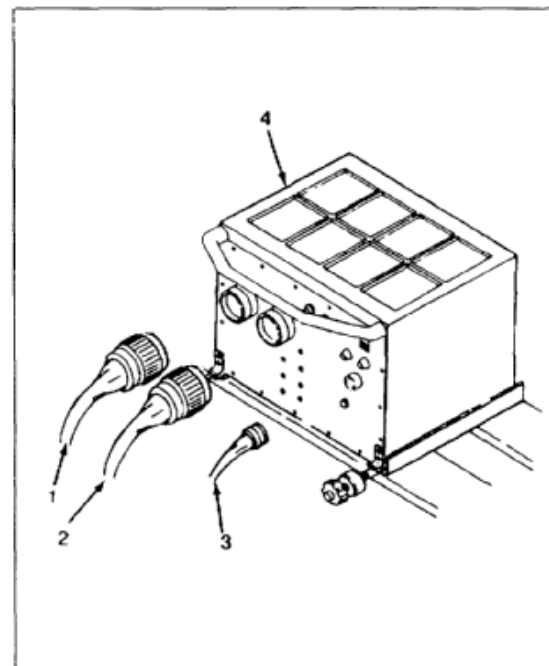



**16-88 REMOVE SIGNAL DATA CONVERTER (Continued)****16-88**

2. Turn two knobs (3) counterclockwise until collars (4) are loose. Slide collars (4) aft from holddown hooks (5).
3. Pull signal data converter (2) aft from mount holddown (6). Lift and remove signal data converter (2) from mounting base (7).

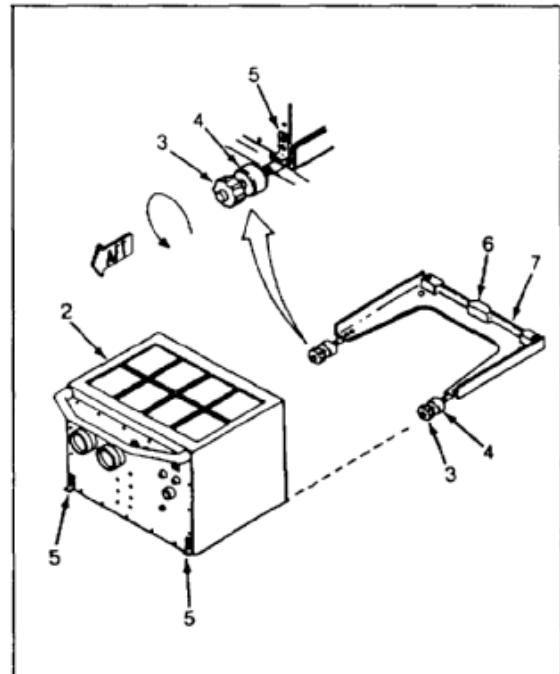
**FOLLOW-ON MAINTENANCE:**

None

END OF TASK

**Applicable Configurations:**

All

**Tools:**

Aircraft Mechanic's Tool Kit, NSN 5180-00-323-4692

**Materials:**

None

**Personnel Required:**

Medium Helicopter Repairer  
Inspector

**References:**

TM 55-1520-240-23P  
TM 11-5855-300-23&P

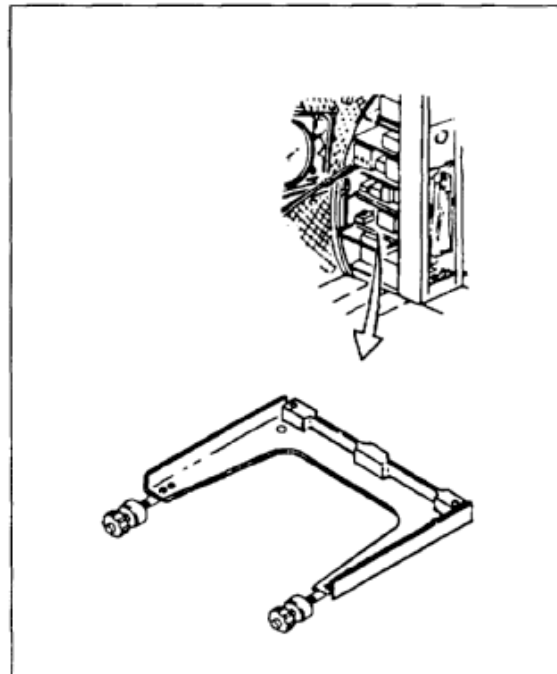

1. Position signal data converter (1) on mounting base (2). Push signal data converter forward until mounting base tab (3) fits into indentation at bottom of signal data converter.
2. Position two collars (4) on holddowns (5). Turn two knobs (6) clockwise until tight.

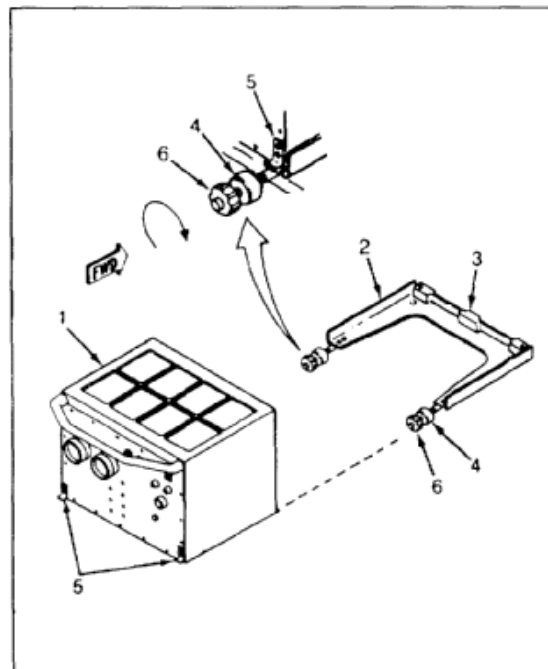

**16-89 INSTALL SIGNAL DATA CONVERTER (Continued)****16-89**

3. Connect connector (7) to receptacle (8).
4. Connect connector (9) to receptacle (10).
5. Connect connector (11) to receptacle (12).

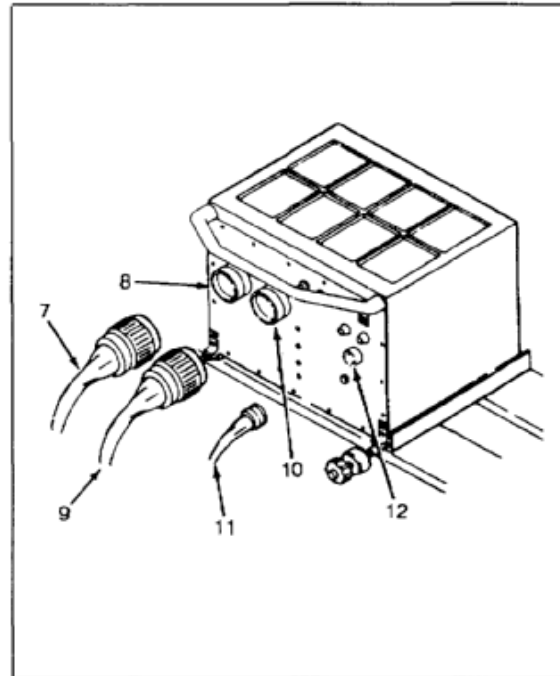
**INSPECT****FOLLOW-ON MAINTENANCE:**

- Perform operational check of signal data converter (SDC) (TM 55-1520-240-T).
- Install Vertical Gyro (TM 11-1520-240-20).
- Install Battery Unit (TM 11-1520-240-20).
- Install Electronic Compartment Acoustic Blanket (Task 2-107).

END OF TASK



## INITIAL SETUP

**Applicable Configurations:**

All

**Tools:**

Electrical Repairer's Tool Kit, NSN 5180-00-323-4915

**Materials:**

None

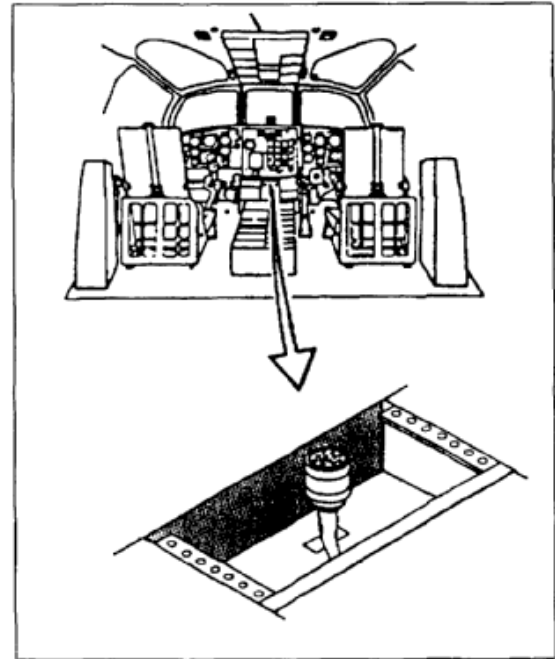
**Personnel Required:**Aircraft Electrician  
Inspector**References:**TM 55-1520-240-23P  
TM 11-5855-300-23&P

1. Connect plug (1) to converter control unit (2).
2. Position converter control unit (2) in console (3).
3. Tighten four fasteners (4).

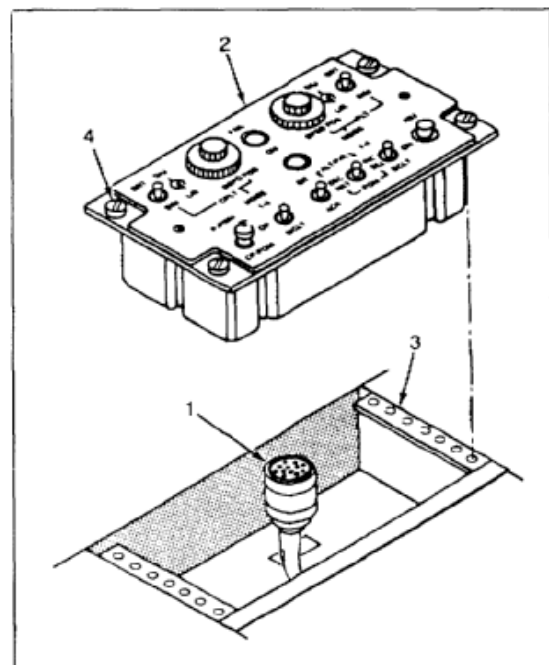
**INSPECT****FOLLOW-ON MAINTENANCE:**Perform operational check of converter control unit  
(TM 55-1520-240-T).

END OF TASK

**Applicable Configurations:**

All

**Tools:**

Aircraft Mechanic's Tool Kit, NSN 5180-00-323-4692

**Materials:**

Paper Tags (E264)

**Personnel Required:**

Medium Helicopter Repairer

**Equipment Condition:**

Battery Disconnected (Task 1-39)

Electrical Power Off

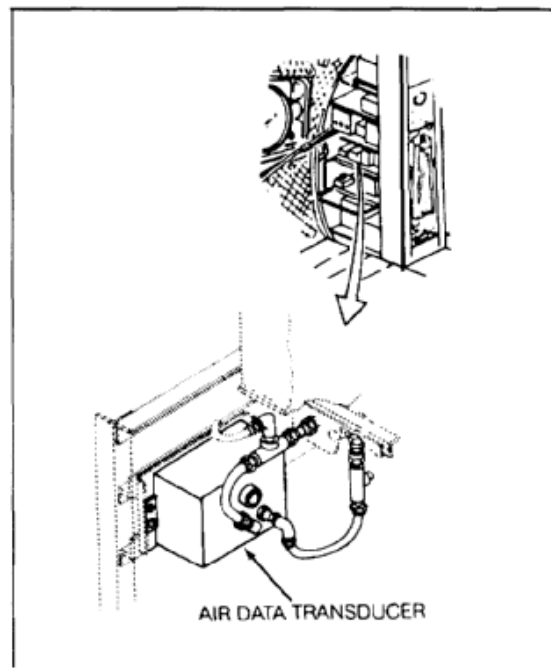
Electronic Compartment Acoustic Blanket Removed  
(Task 2-107)

1. Tag (E264) and disconnect electrical connector (1) from transducer (2).
2. Tag (E264) and disconnect PITOT PRESS air hose (3) from transducer (2).
3. Tag (E264) and disconnect STATIC PRESS air hose (4) from transducer (2).
4. Remove four screws (5) and washers (6).
5. Remove transducer (2) from mounting plate (7).

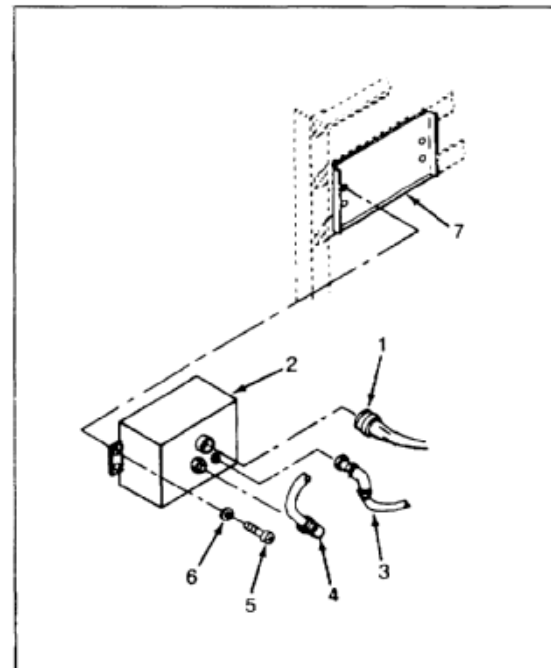
**FOLLOW-ON MAINTENANCE:**

None

END OF TASK

16-340

**Applicable Configurations:**

All

**Tools:**

Aircraft Mechanic's Tool Kit, NSN 5180-00-323-4692

**Materials:**

None

**Personnel Required:**Medium Helicopter Repairer  
Inspector**Equipment Condition:**

TM 55-1520-240-23P

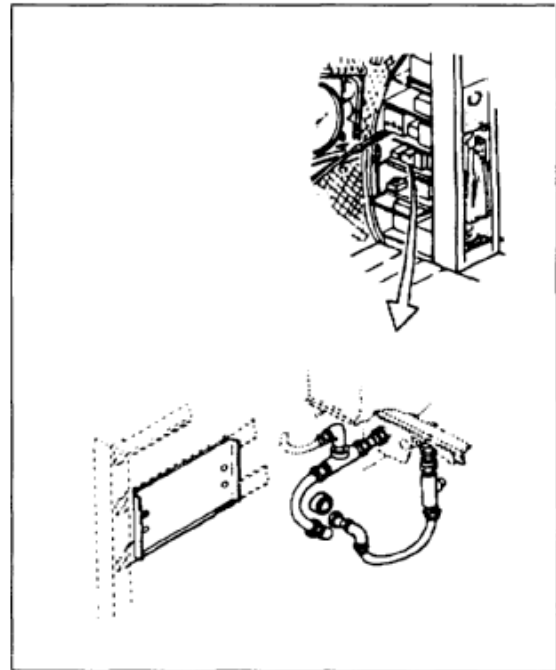

1. Position transducer (1) on mounting plate (2). Install four screws (3) and washers (4).
2. Connect PITOT PRESS air hose (5). Remove tag.
3. Connect STATIC PRESS air hose (6). Remove tag.
4. Connect electrical connector (7). Remove tag.

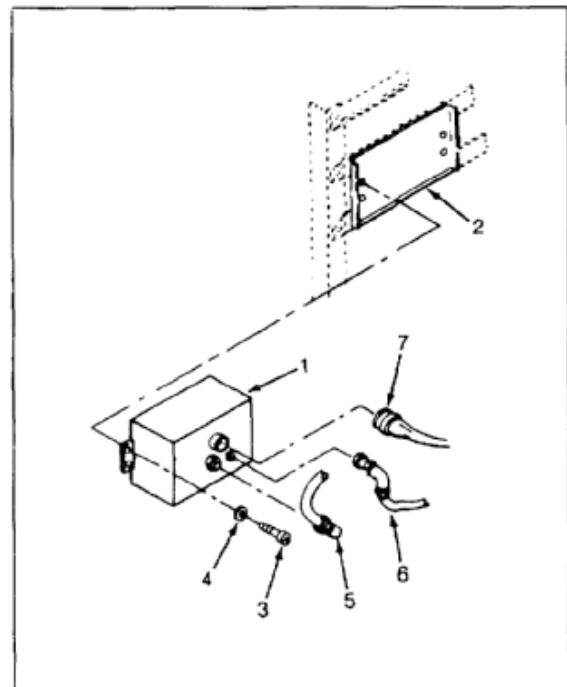
**INSPECT****FOLLOW-ON MAINTENANCE:**

Perform leak check of pitot-static system (TM 55-1520-240-T).

END OF TASK

**Applicable Configurations:**

All

**Tools:**

Aircraft Mechanic's Tool Kit, NSN 5180-00-323-4692

**Materials:**

Paper Tags (E264)

**Personnel Required:**

Medium Helicopter Repairer

**Equipment Condition:**

Battery Disconnected (Task 1-39)

Electrical Power Off

Electronic Compartment Acoustic Blanket Removed  
(Task 2-107)

Amplifier-Coupler Removed (TM 11-1520-240-20)

Receiver-Transmitter Removed (TM 11-1520-240-20)

KY-75 Processor Removed (TM 11-1520-240-20)

IFM Amplifier Removed (TM 11-1520-240-20)

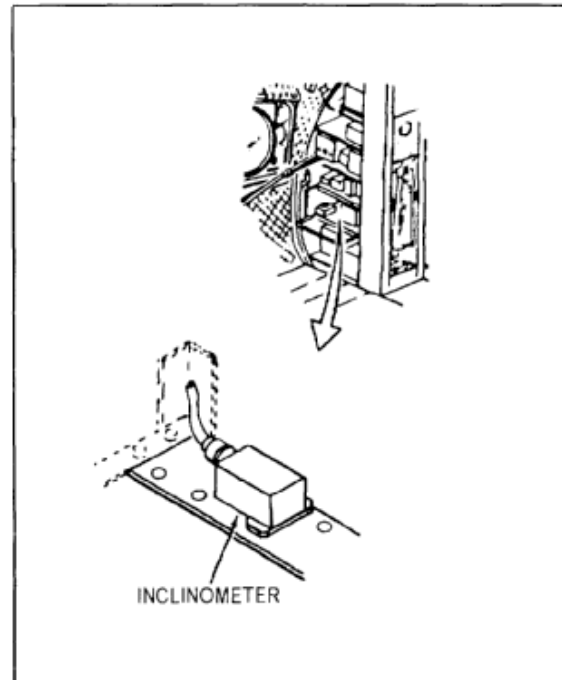

1. Tag (E264) and disconnect connector (1) from inclinometer (2).
2. Loosen four captive screws (3).

**NOTE**

If shim(s) (4) are installed, note location and retain for reinstallation.

3. Remove inclinometer (2) and shim(s) (4) from shelf (5).

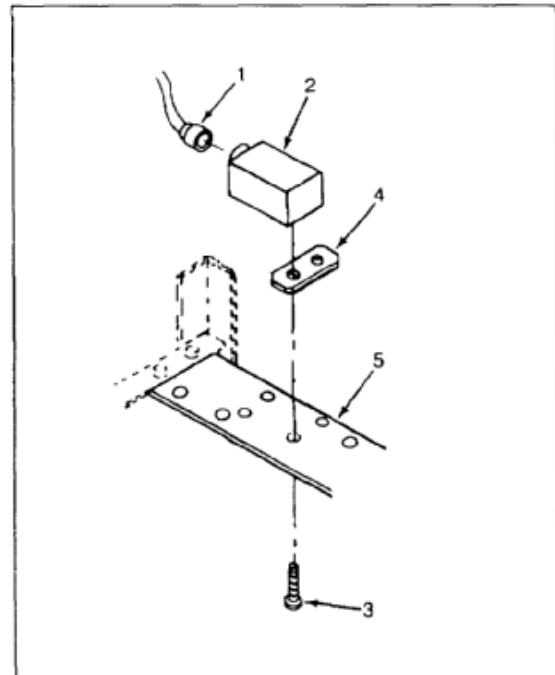
**FOLLOW-ON MAINTENANCE:**

None

END OF TASK

16-342



**16-95 INSTALL INCLINOMETER SENSOR****16-95****Applicable Configurations:**

All

**Tools:**

Aircraft Mechanic's Tool Kit, NSN 5180-00-323-4692

**Materials:**

Heads Up Display (HUD) Display Unit With Power Supply AN/AV-7 ANVIS

**Personnel Required:**

Medium Helicopter Repairer  
 Inspector  
 Aircraft Electrician  
 N1 Qualified Pilot

**References:**

TM 55-1520-240-23P  
 TM 11-1520-240-23  
 TM 55-1520-240-T  
 Task 1-21  
 Task 1-39  
 Task 2-107  
 Task 16-94

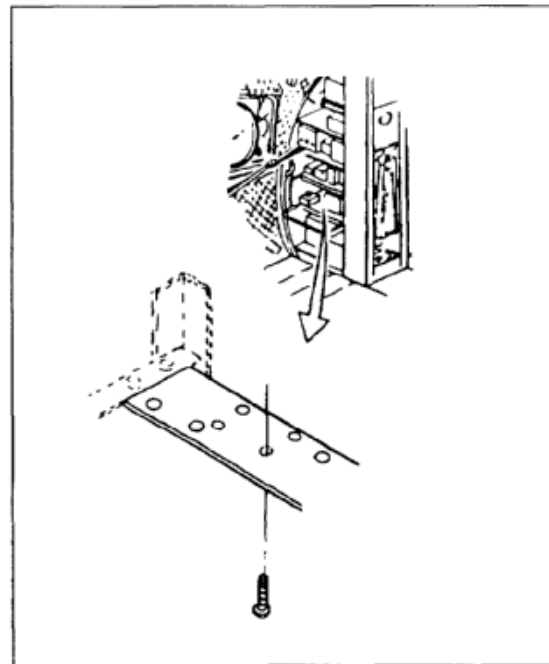

1. If installed, position shim(s) (5) and inclinometer (1) on shelf (2).
2. Tighten four captive screws (3).
3. Connect connector (4) to inclinometer (1).

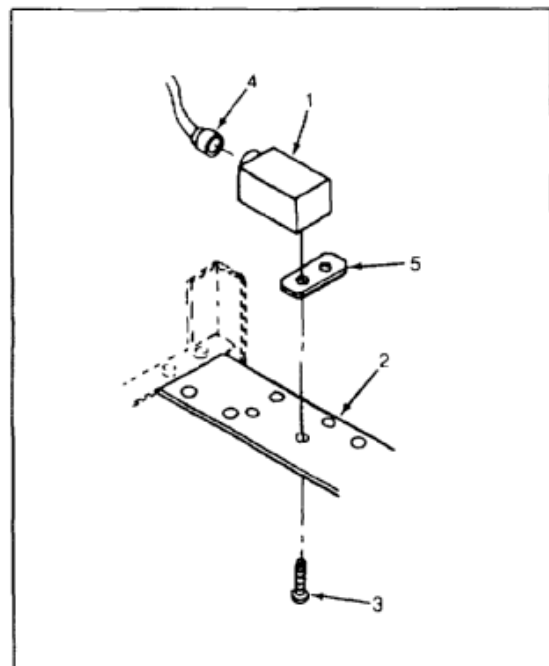
**INSPECT**

**ADJUST INCLINOMETER**

4. Level aircraft (Task 1-21).
5. Connect battery (Task 1-39) and apply aircraft electrical power.
6. Apply power to head up display system and check for proper operation (TM 55-1520-240-T).
7. While utilizing the ANVIS HUD goggles with appropriate filters for lighting conditions, view turn and bank indicator ball. If turn and bank indicator ball is centered, go to step 14. If position of turn and bank indicator ball is not centered, go to step 8.
8. Turn off head up display system.
9. Turn off aircraft power and disconnect battery (Task 1-39).
10. Remove inclinometer (Task 16-94).
11. Insert shim(s) as required under inboard or outboard end of inclinometer, in the direction of error.
12. Install inclinometer steps 1 thru 3.
13. Repeat steps 5 thru 12 until turn and bank indicator ball is centered in head up display.
14. Turn off head up display.
15. Turn off aircraft power and disconnect battery (Task 1-39).
16. Lower aircraft (Task 1-21).

**INSPECT****FOLLOW-ON MAINTENANCE:**

Install Amplifier-Coupler (TM 11-1520-240-23).  
 Install Receiver-Transmitter (TM 11-1520-240-23).  
 Install KY-75 Processor (TM 11-1520-240-23).  
 Install IFM Amplifier (TM 11-1520-240-23).  
 Install Electronic Compartment Acoustic Blanket (Task 2-107).

**NOTE**

The inclinometer is level when the turn and bank indicator ball is centered in the ANVIS HUD goggles. One shim will shift the turn and bank indicator ball approximately **one-tenth** of its diameter.

**Tasks 16-96 Deleted.**

END OF TASK

**SECTION XV**  
**EXTENDED RANGE FUEL SYSTEM (ERFS II) DESCRIPTION AND OPERATION**

**DESCRIPTION**

The extended range fuel system (ERFS II) consists of one, two, or three **800 gallon** fuel tanks, a restraint system for each tank, interconnecting hoses for using multiple tanks, hoses for interfacing with the aircraft and an electrical wire harness to provide power from the aircraft to the control panel. There is also a forward area refueling equipment (FARE) kit provided.

The ERFS II can be pressure refueled through the aircraft pressure refueling system (Chapter 10) or gravity filled through the openings on the top of each tank.

Four cavity drains are installed through the cabin floor at BL 48, sta 290, 336, 370, and 443 to provide drainage

to the outside of the aircraft in case fuel should ever migrate to the cavity between the outer tank and the bladder of the ERFS II tank.

Three ERFS II vents are located at WL 18, sta 254, 331, and 410 along the left side of the aircraft. These vents provide air to the tanks during normal operation and vents fuel vapors overboard.

Detailed description and operation information can be found in the Extended Range Fuel System manuals TM 1-1560-312-10 or TM 1-1560-312-23 & P.

END OF TASK

**SECTION XVI**  
**EXTENDED RANGE FUEL SYSTEM (ERFS II)**

## INITIAL SETUP

**Applicable Configuration:**With **82****Tools:**

Aircraft Mechanic's Tool Kit, NSN 5180-00-323-4692

**Materials:**

None

**Personnel Required:**

Medium Helicopter Repairer

**Equipment Condition:**Battery Disconnected (Task 1-39)  
Electrical Power Off**NOTE**

Removal procedures are similar for the four cavity drain elbow fittings. They are located in the cabin at BL 48, WL -30, sta 290, sta 336, sta 370 and sta 443.

1. Remove the cabin floor panels to gain access to the drain (8) and elbow fitting (2).
2. Loosen the clamps (6) attaching the hose of the elbow (2) and the drain (8).
3. Remove the hose (7) from the drain and the elbow fitting.
4. Remove the nut (3) and washer (4) from the elbow fitting (2).
5. Remove the elbow fitting (2).
6. Remove drain fitting by removing the nut (5) and washer (4).

**FOLLOW-ON MAINTENANCE:**

None

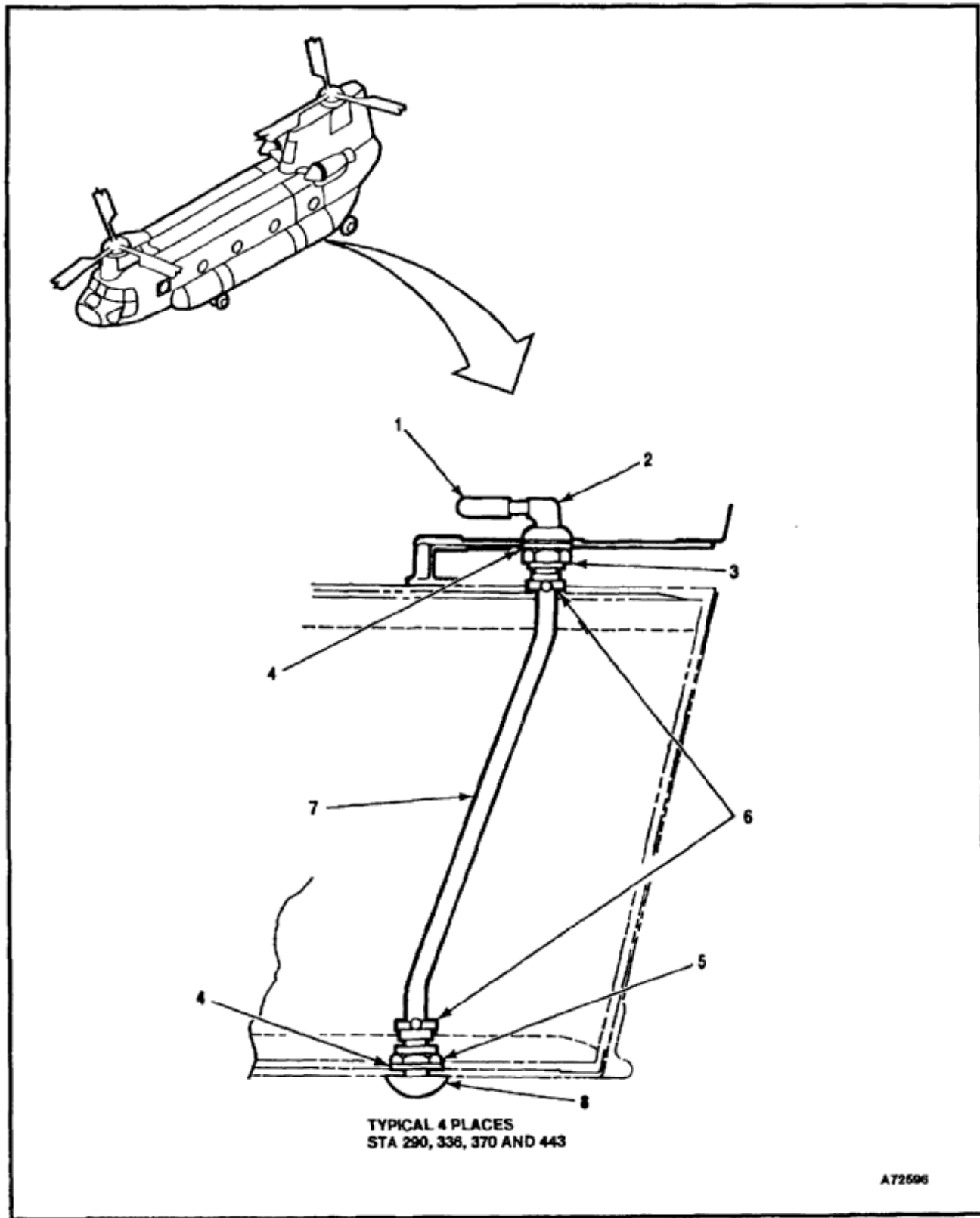

## INITIAL SETUP

**Applicable Configuration:**

With **82**

**Tools:**

Aircraft Mechanic's Tool Kit, NSN 5180-00-323-4692

**Materials:**

None

**Personnel Required:**

Medium Helicopter Repairer (2)

1. Install elbow fitting (2) with cap (1) through hole in floor and install washer (4) and nut (3).
2. Orient the fitting facing **45°** inboard. Tighten nut (3).
3. Install hose (7) on elbow fitting (2) with clamp (6). Tighten clamp (6).
4. Have helper hold drain fitting (8) in place.
5. Install washer (4) and nut (5) on drain fitting (8). Tighten nut.
6. Install clamp (6) onto hose (7) and install hose onto drain fitting (8).
7. Install clamp (6) on hose (7) at drain fitting (8) and tighten.

**FOLLOW-ON MAINTENANCE:**

None



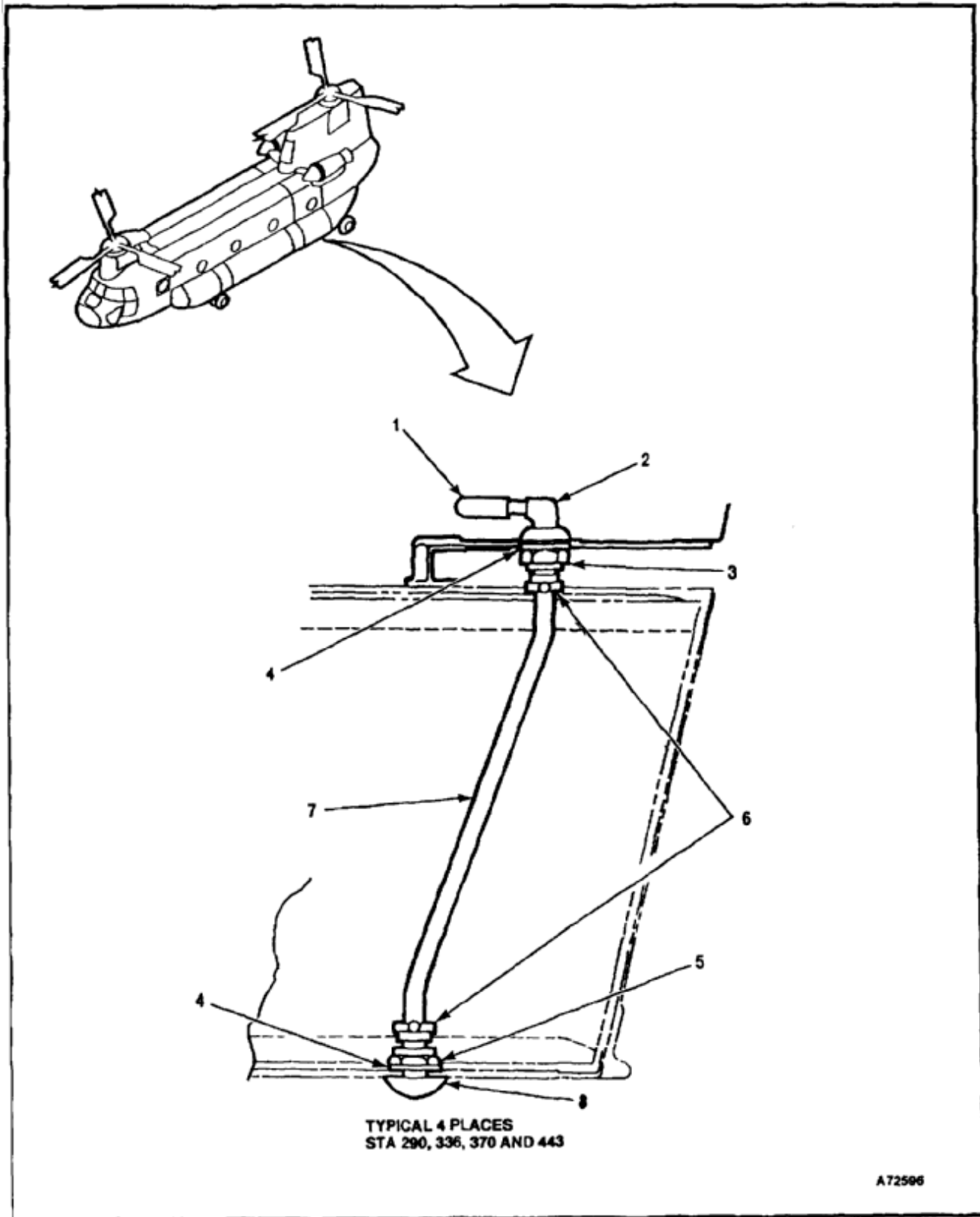



**SECTION XVII**  
**ENGINE AIR PARTICLE SEPARATOR SYSTEM (EAPS)**  
**PROVISIONS DESCRIPTION AND OPERATIONS**

**Description:**

The Engine Air Particle Separator System (EAPS) provides sand and dust protection for CH-47D engines in sandy regions to assure normal engine life for sustained operations. Primary components are the engine air particle separator mounted on rails, the EAPS control panel in the overhead switch panel, two control boxes, one at each side of the helicopter at approximate sta. 400.0, six circuit breakers, three on each power distribution panel (PDP) extension box, and EAPS 1 FAIL and EAPS 2 FAIL capsules on the master caution panel.

**Power Distribution Panel (PDP) Extension Boxes.**

Both No. 1 and NO. 2 PDP's have an extension box attached to the top. Each extension box is connected to the power distribution panel and structure by screws. Entry to the box is permitted through an access door. A **5 amp FAN CONT**, **5 amp BYPASS DOORS**, and **25 amp FAN** circuit breaker is installed on each extension box access door. Wire is routed through a hole in the PDP's to the circuit breakers. A lamp stowage box is mounted on top of the No. 1 extension box.

**Master control panel.** Two caution lights marked EAPS 1 FAIL and EAPS 2 FAIL are on the master caution panel. These lights will come on when the difference in pressure between the inside and outside of the EAPS exceeds **10 psi** indicating a clogged EAPS. This is detected by a differential pressure switch in the EAPS unit.

**EAPS control panel.** The EAPS control panel is installed on the left side of the overhead switch panel. There are four toggle switches mounted on the EAPS control panel which control fan and door operation. The ENG 1 and ENG 2 FAN switches electrically operate the two fans. When the switches are ON, the fans are operating. The switches receive power from No. 1 and No. 2 **28-vdc** buses through circuit breakers EAPS 1 and EAPS 2 FAN CONT on the power distribution panel (PDP) extension box. The switches control the relays in the EAPS control box and the relays power

the fans with **3-phase ac 400 Hz**. The fans discharge scavenged debris downwards and rearwards away from the separator. The ENG 1 and ENG 2 DOORS switches electrically position the bypass doors open or closed. Both switches receive **28 vdc** power from No. 1 and No. 2 buses through circuit breakers marked EAPS 1 and EAPS 2 BYPASS DOORS on the power distribution panel (PDP) extension boxes. The bypass mechanism provides an emergency system to enable the engines to continue running in the event of airborne debris being sucked into the separator.

**EAPS control boxes.** Two control boxes are installed in the aft cabin section of the helicopter. No. 1 control box is for the left EAPS system and is located at sta. 390. No. 2 control box is for the right EAPS system and is located at sta. 410. Each box contains a relay, terminal boards, and an EAPS BYPASS DOORS OPEN press-to-test light. The relays provide ac power to the EAPS fans in the separators, when the fan switches in the cockpit are ON. The EAPS BYPASS DOORS OPEN press-to-test light indicates when the separator bypass doors are open, when the cockpit switches are at OPEN.

**Engine Air Particle Separator**

The EAPS is divided into four sections; separator section which includes the body, tubes and seals, scavenge section which includes ducts and scavenge blower, the FOD screen section which includes two screens, the bypass section with differential pressure switch, two bypass doors and two actuators. Contaminated air enters the EAPS through more than 3,000 inlet swirl tubes, or vortex generators, installed in its exterior surface. Each inlet swirl tube forces incoming air to form a swirling pattern. Centrifugal force throws the heavier-than-air contaminants to the outside of the swirling air streams, thereby dividing them into two parts; dirty air at the swirls rim, and clean air at the core. The dirty air is vented overboard through the scavenge system, while the clean air continues into the engine. In the event an obstruction covers enough inlet tubes to cause engine oxygen starvation, the EAPS normal operation can be bypassed, restoring engine power by using uncleaned air.



**16-101 REMOVE POWER DISTRIBUTION PANEL (PDP), EXTENSION BOX, AND CIRCUIT BREAKERS**

16-101

**INITIAL SETUP****Applicable Configurations:**

All

**Tools:**

Electrical Repairer's Tool Kit, NSN 5180-00-323-4915

**Materials:**

None

**Personnel Required:**

Aircraft Electrician

**Equipment Condition:**

Battery Disconnected (Task 1-39)

Electrical Power Off

Hydraulic Pressure Off

**NOTE**

No. 2 PDP extension box shown.  
Procedure is similar to remove  
extension box and circuit breakers  
from No. 1 PDP.

1. Loosen eight fasteners (1) and remove the door (2).
2. Tag and disconnect wires (3) by removing screws (4) and washers (5).
3. Remove the nuts (6) and circuit breakers (7).
4. Loosen six fasteners (8) and open door (9).
5. Remove screw (10), washer (11), and clamp (12). Remove screw (13), washer (14), nut (15), clamp (16).
6. Remove five screws (19), washers (20), and nuts (21). Remove five screws (22), washers (23). Lift box (18) off PDP (24).
7. If No. 1 extension box is being replaced, remove bulb stowage box.

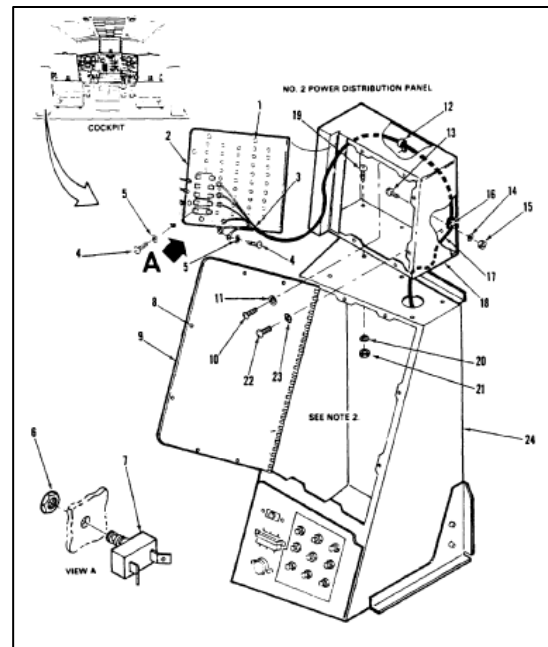
**FOLLOW-ON MAINTENANCE:**

As Required

END OF TASK

16-356

---

**16-102 INSTALL POWER DISTRIBUTION PANEL (PDP) EXTENSION BOX AND CIRCUIT BREAKERS**

---

16-102

**INITIAL SETUP****Applicable Configurations:**

All

**Tools:**

Electrical Repairer's Tool Kit, NSN 5180-00-323-4915

**Materials:**

None

**Personnel Required:**

Aircraft Electrician

**References:**

TM 55-1520-240-23  
 TM 55-1520-240-23P  
 TM 55-1520-240-T

**NOTE**

No. 2 PDP extension box shown.  
 Procedure is similar to remove extension box and circuit breakers from No. 1 PDP.

1. Feed the harness (17) into the extension box (18). Position the extension box on top of the PDP (24) and align the mounting holes for the attaching hardware.
2. Install the five screws (19), washers (20), and nuts (21) to attach the extension box (18) to the PDP (24).
3. Install the five screws (22) and washers (23) that fasten the extension box (18) to the back structure.
4. Install circuit breakers (7) and secure with nuts (6).
5. Connect wires (3) to the circuit breakers (7) with screws (4) and washers (5) (Refer to TM 55-1520-240-T). Remove tags.
6. Clamp harness (17) to back of extension box (18) using screws (10), washers (11), and clamp (12). Clamp harness to side of box using screw (13), clamp (16), washer (14), and nut (15).
7. Secure door (2) to the extension box (18) with eight fasteners (1).
8. Secure door (9) to PDP (24) with six fasteners (8).
9. If No. 1 extension box is being replaced, install bulb stowage box.
10. Perform operational check of system. Refer to TM 55-1520-240-T.

**FOLLOW-ON MAINTENANCE:**

As Required

END OF TASK

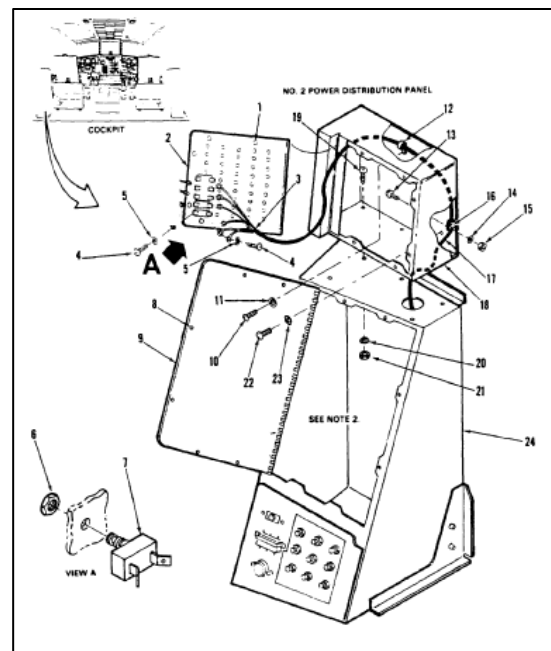

## INITIAL SETUP

**Applicable Configurations:**

All

**Tools:**

Electrical Repairer's Tool Kit, NSN 5180-00-323-4915

**Materials:**

None

**Personnel Required:**

Aircraft Electrician

**Equipment Condition:**

Battery Disconnected (Task 1-39)

Electrical Power Off

Hydraulic Pressure Off

**REMOVE LIGHTPLATE AS FOLLOWS:**

- Loosen captive screws (1) from lightplate (2).



There may be an unlighted lightplate installed at this time. However if a lighted panel is installed caution should be used when replacing it to avoid damage to the light connector (3). A white cross (5) on face of lightplate indicates location of electrical connector.

- Carefully pull lightplate (2) away from panel (4) to separate lightplate from connector (3) behind white cross (5).

**REMOVE SWITCH, LIGHT, OR PANEL AS FOLLOWS:**

- Turn fasteners (6) 1/4 turn counterclockwise.
- Pull panel (4) away from overhead panel (7) far enough to gain access to switch (8).
- Tag electrical wires (9). Remove screws (10), washers (11), and electrical wires from switch (8).
- Remove nut (12), lockwasher (13), and locking ring (14) from front of panel (4). Remove switch (8) from back of panel.
- Remove screw (16), washer (17), and wire (18). Tag wire.
- Remove nut (19), lockwasher (20), and ground lug (21).
- Remove light receptacle (22) from panel (4).

**FOLLOW-ON MAINTENANCE:**

None

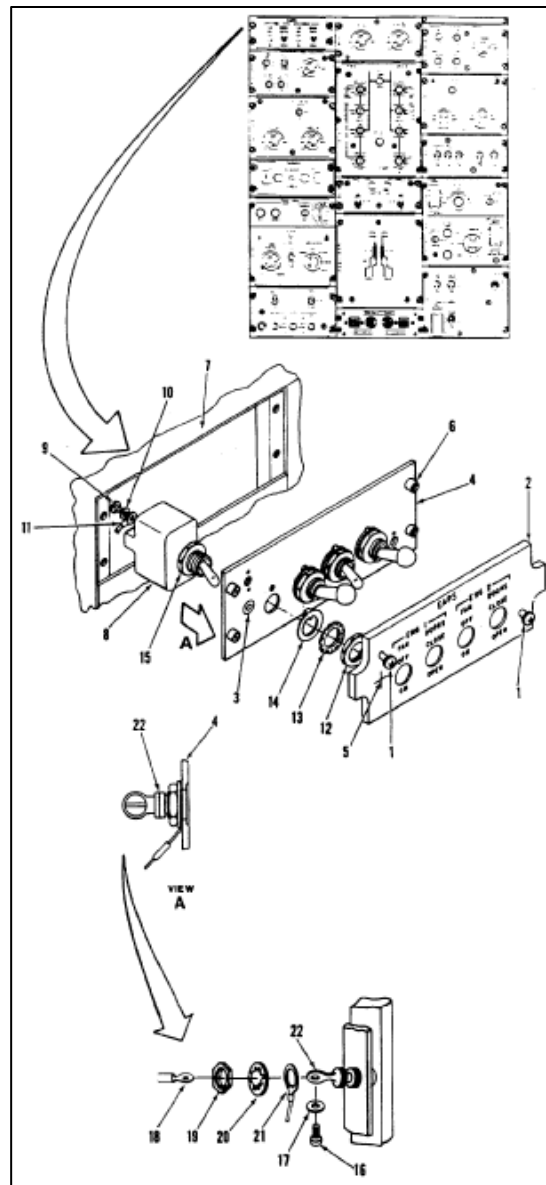

END OF TASK

16-358



## INITIAL SETUP

**Applicable Configurations:**

All

**Tools:**

Electrical Repairer's Tool Kit, NSN 5180-00-323-4915

**Materials:**

None

**Personnel Required:**

Aircraft Electrician

**References:**

TM 55-1520-240-23P

TM 55-1520-240-T

**INSTALL SWITCHES AS FOLLOWS:**

1. Remove top nut (12), lockwasher (13), and locking ring (14) from the serviceable switch (8).
2. Adjust locknut (15) to same position as on removed switch (8).
3. Insert switch (8) through back of panel (4). Install locking (14), lockwasher (13), and nut (12) from front of panel.
4. Install wires (11), washers (10), and screws (9) on switch (8). (Refer to TM 55-1520-240-T.) Remove tags.

**INSTALL LIGHT RECEPTACLE AS FOLLOWS:**

5. Insert receptacle (22) in panel (4).
6. Install ground lug (21), lockwasher (20), and nut (19) on receptacle (22).
7. Install wire (18), washer (17), and screw (16). Remove tag.



There may be an unlighted lightplate installed at this time. However, if a lighted panel is installed, caution should be used when replacing it to avoid damage to the light connector (3). A white cross (5) on face of lightplate indicates location of electrical connector.

8. Position panel (4) on overhead panel (7). Turn fasteners (6) 1/4 turn clockwise to secure panel.

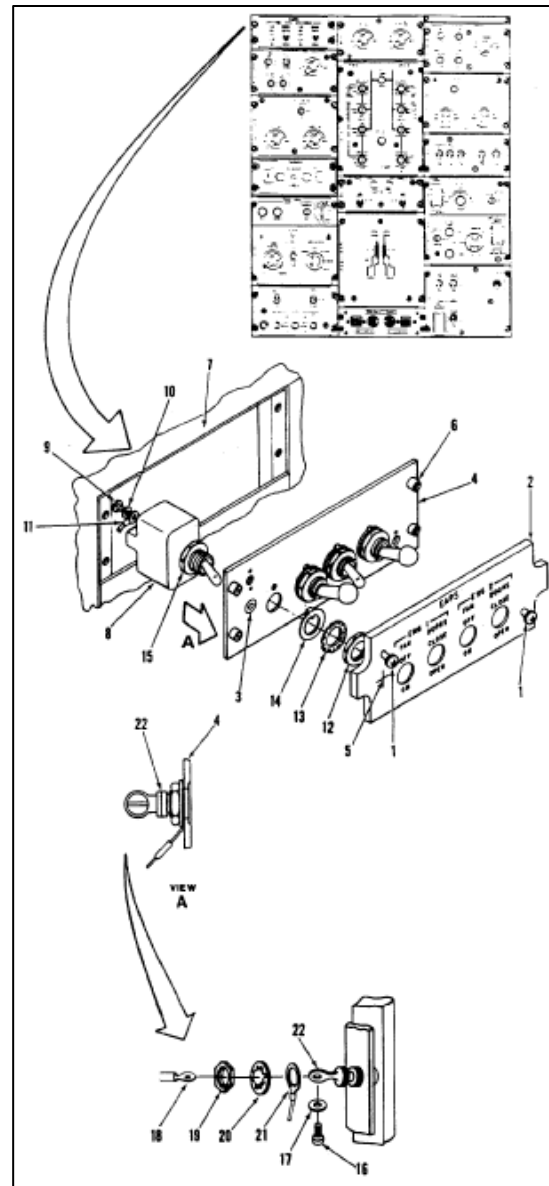

**INSTALL LIGHTPLATE AS FOLLOWS:**

9. Align cross (5) on lightplate (2) with connector (3) on panel (4).
10. Push plug behind cross (5) into connector (3). Press on cross to ensure plug is seated.
11. Tighten captive screws (1).
12. Perform operational check of system. (Refer to TM 55-1520-240-T.)

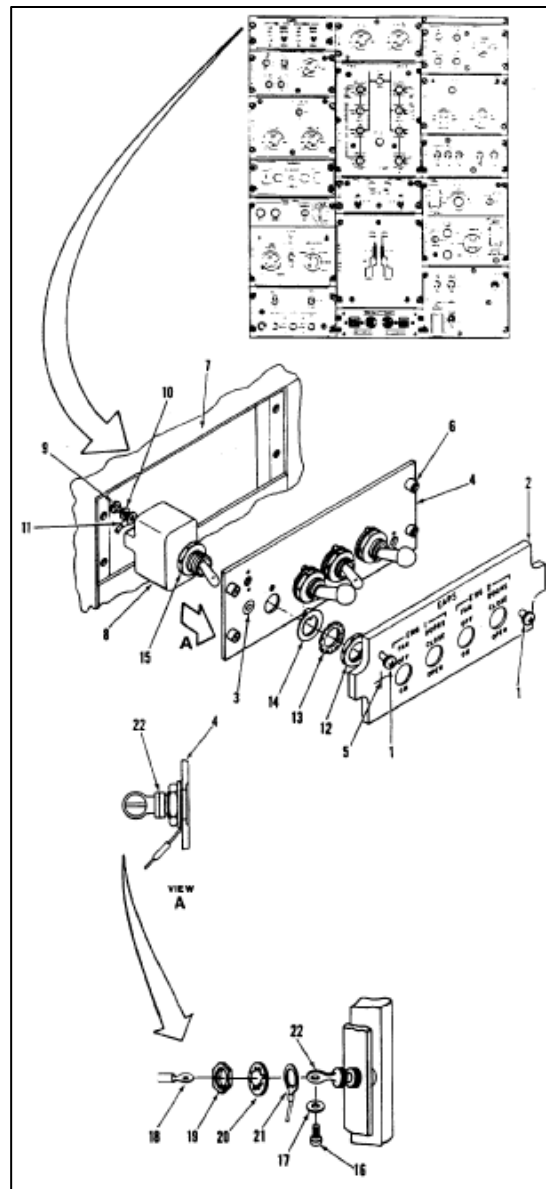
**FOLLOW-ON MAINTENANCE:**

As Required

END OF TASK

16-360

**16-105 REMOVE EAPS CONTROL BOX****16-105****INITIAL SETUP****Applicable Configurations:**

All

**Tools:**

Electrical Repairer's Tool Kit, NSN 5180-00-323-4915

**Materials:**

None

**Personnel Required:**

Aircraft Electrician

**References:**

Battery Disconnected (Task 1-39)  
 Electrical Power Off  
 Hydraulic Pressure Off

**NOTE**

No. 1 control box shown. Procedure to remove No. 2 control box is similar.

1. Disconnect two electrical connectors (1) from control box (2).
2. Loosen six fasteners (3) and remove cover (4).
3. Remove four screws (5), washers (6), and control box (2) from structure (7).

**FOLLOW-ON MAINTENANCE:**

None

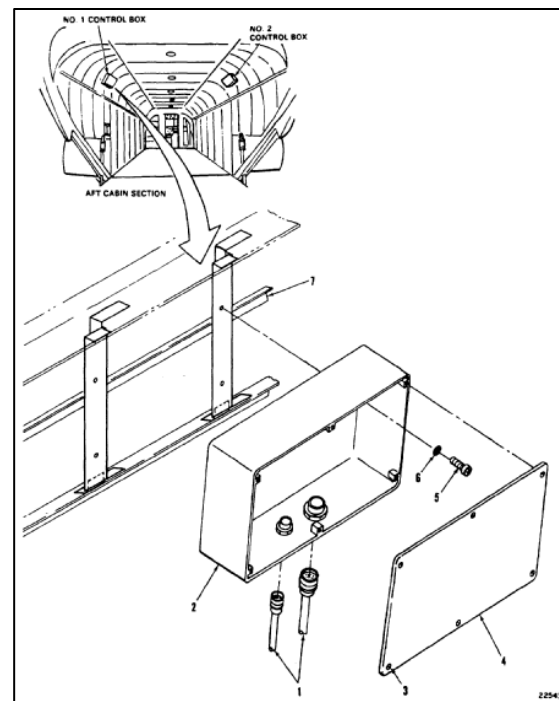
*EAPS Control Box Removal*

END OF TASK

## INITIAL SETUP

**Applicable Configurations:**

All

**Tools:**

Electrical Repairer's Tool Kit, NSN 5180-00-323-4915

**Materials:**

None

**Personnel Required:**

Aircraft Electrician

**References:**

TM 55-1520-240-23P

TM 55-1520-240-T

**NOTE**

No. 1 control box shown. Procedure to install No. 2 control box is similar.

1. Remove cover (4) if installed. Position control box (2) on structure (7) and secure with four screws (5) and washers (6).
2. Connect two electrical connectors (1) to the control box (2).
3. Install cover (4) and secure six fasteners (3).
4. Perform operational check of system. (Refer to TM 55-1520-240-T.)

**FOLLOW-ON MAINTENANCE:**

As Required

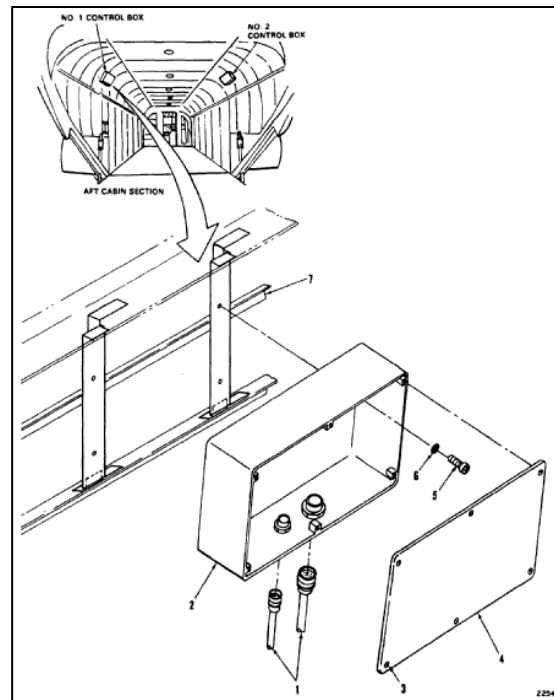

EAPS Control Box Removal

END OF TASK

16-362

## INITIAL SETUP

**Applicable Configuration:**

All

**Tools:**

3K Fork Lift or equivalent

Overhead Hoist  
 General Mechanic's Tool Kit NSN 5180-00-323-4692  
 Guide Ropes (2)

**Personnel Required:**

Fork Lift Operator  
 Medium Helicopter Repairer (2)

**NOTE**

The shipping container is the ONLY approved method for shipping and storing the EAPS when not installed

Surface and Inlet Swirl Tubes — EAPS is made of lightweight metal and has thousands of plastic inlet swirl tubes. Surface contact with hard objects can damage plastic tubes and/or sheet metal surfaces.

Diffuser Duct — Diffuser duct is made of fiberglass and can be easily damaged. Do not place weight of EAPS on diffuser.

Cables and Lanyards — Do not allow cables to snag or drag. An electrical dummy receptacle is provided.

1. Lift container using a fork lift in slots (1) provided, or use a hoist or crane connected to tie-down rings installed on each side of container. Tie-down rings (2) can also be used for tie down during transport.



Do not attempt to lift container using only upper handles.

2. Use handles (3) on upper half of container to remove it from lower half. Use handles on lower half to lift or move container.
3. Secure upper and lower halves together using locking fasteners (4).
4. During periods of nonoperation, install dust covers (5) on EAPS. Two covers connected by a lanyard are used to protect each EAPS. The large cover protects EAPS body and inlet swirl tubes, and the small cap-type cover protects the diffuser duct outlet.

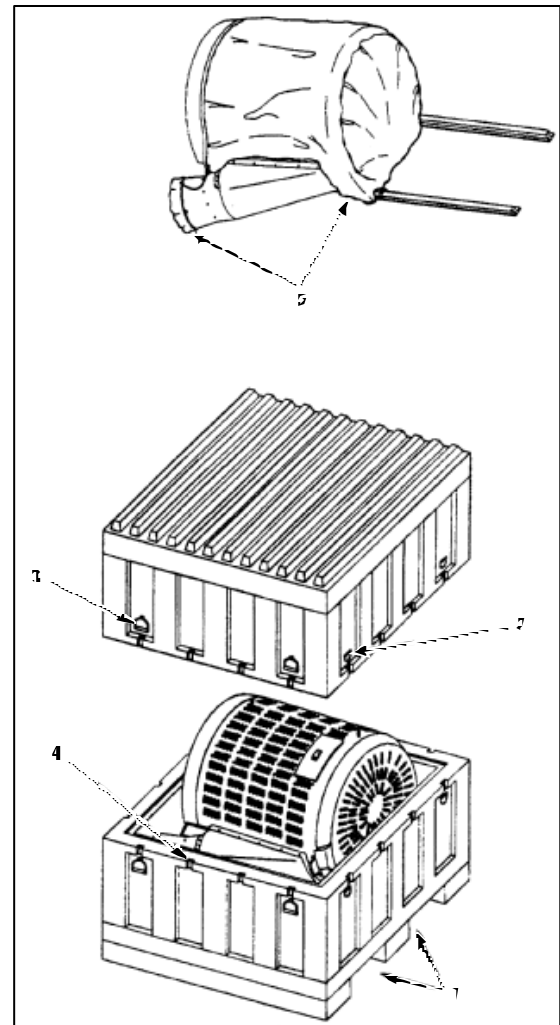

**Shipping & Storage Container with Dust Cover**

END OF TASK

INITIAL SETUP

**Applicable Configurations:**

All

**Tools:**

General Mechanic's Tool Kit, NSN 5180-00-323-4692

**Materials:**

Parts Kit, Aircraft Group, PN# AC 8101-1008KT  
Hand Protection Or Gloves

**Personnel Required:**

Airframe Sheetmetal Repairer  
Inspector

**Equipment Conditions:**

Off Helicopter Task  
EAPS Removed (Task 16-109)

Tubes replaced should be widely scattered and not concentrated in any area of the air cleaner.

1. Using needle nose pliers, remove inlet tube (1) by carefully gripping center of tube and twisting to break tube into pieces.



Do not damage rim of hole in inlet panel or pull with excessive force causing damage to thin gage metal tabs on rim of hole.

2. Carefully insert new tube into hole and press into place using a clean cloth for thumb protection.
3. When groove of tube fully engages panel hole, tube is properly installed. Tube must not rotate or be loose.

**NOTE**

The maximum number of replaced tubes should not exceed **10 percent** of the total tybes in the air cleaner.

**INSPECT**

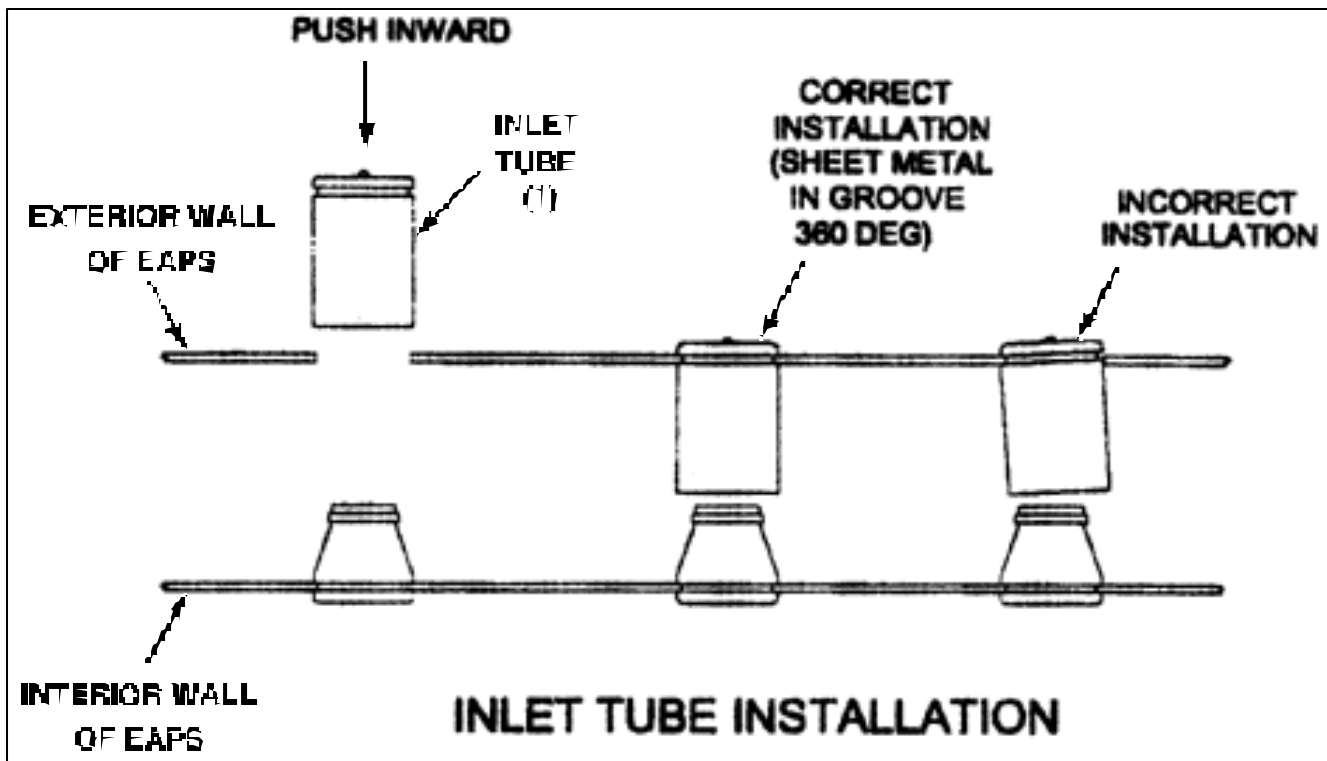

**FOLLOW-ON-MAINTENANCE:**

Install EAPS (Task 16-110).

END OF TASK

**16-109 REMOVE ENGINE AIR PARTICLE SEPERATOR (EAPS)****16-109****INITIAL SETUP****Applicable Configurations:**

All

**Tools:**

General Mechanic's Tool Kit, NSN 5180-00-323-4692  
 EAPS Lifting Device (T188)  
 Hoist  
 Vacuum Cleaner

**Materials:**

Cloth (E120)  
 Detergant (E159.1)

**Personnel Required:**

Medium Helicopter Repairer (3)

**Equipment Condition:**

Battery Disconnected  
 Electric Power OFF  
 Hydraulic Power OFF

1. Remove two nuts (1), washers (2), bolts (3), and bump stop (4) from forward end of each rail (5).

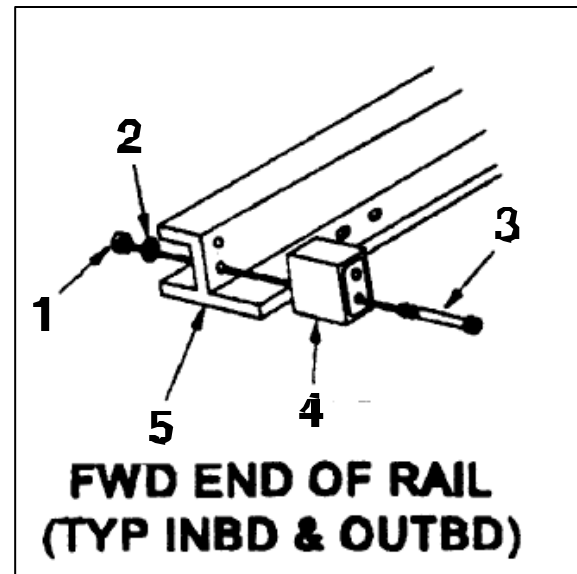

2. Disconnect 1/4 turn fastener (6) holding the electrical cable clamp from aircraft fuselage.
3. Disconnect plug (7) of electrical cable from aircraft and attach to dummy receptacle (8) located on EAPS.
4. Make sure rails are clean and free from dirt or grit.

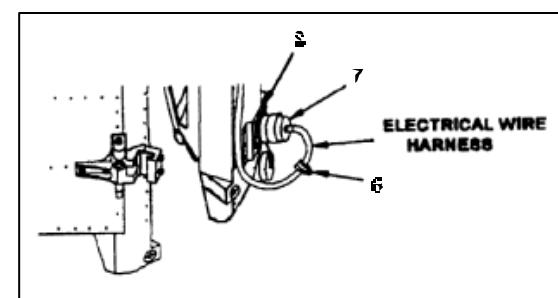

5. Release 1/4 turn fasteners (6) and remove cross shaft link (9).
6. Remove safety clips (10) and open latches on upper cross shaft seal (11).
7. Loosen two shoulder bolts (16) and slide upper cross shaft seal (11) and lower cross shaft seal (15) seal inboard as far as possible.

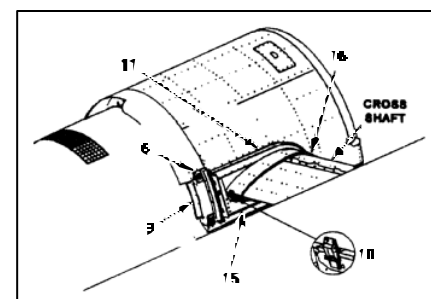

8. Remove quick release pins (12) and secure to prevent snagging lanyards.
9. Bring handles of hook latch (13) and pin latch (14) to a fully open position and secure handles in that position.

**WARNING**

Keep hands clear of rails.

10. Using handle, slowly slide EAPS forward. Stop before forward mounting feet come off rails.
11. Attach EAPS Lifting Device to hoist (T188) and position above EAPS. Connect cables to eye bolts and secure with safety clips.
12. Raise hoist enough to remove slack in cables, but still allow EAPS to slide on rails.
13. Slide EAPS forward slowly until mounting feet are clear of rails. Person on fuselage should help support the weight of the EAPS so it does not contact fuselage.

**CAUTION**

Diffuser duct is made of fiberglass and can be easily damaged. Do not place weight of EAPS on diffuser duct. EAPS is made of lightweight metal and has thousands of plastic inlet swirl tubes. Surface contact with hard objects can damage plastic tubes and/or sheet metal surfaces.

14. Lower EAPS onto a skid or equivalent supporting structure, in a vertical position with inlet facing up. Make sure diffuser duct is not contacting skid or floor.
15. Disconnect EAPS Lifting Device (T188) from EAPS.

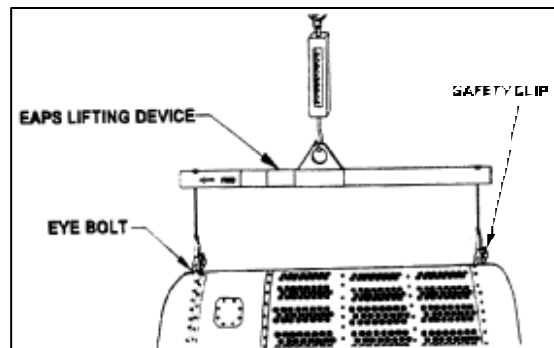
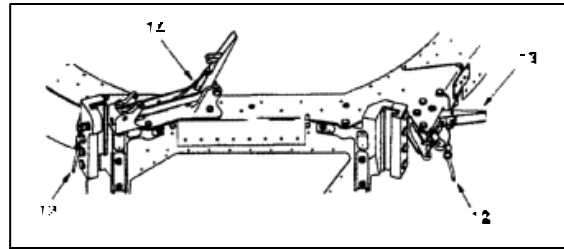



**WARNING**

Use protective equipment to protect eyes and face when you use compressed air. Maximum permitted air pressure is **30 psi** (207 KPA). Do not point compressed air toward yourself or other persons.

**CAUTION**

Do not use solvents to clean the EAPS or its components. Solvents can cause serious damage to inlet swirl tubes, seals, electrical parts, and fiberglass items.

16. Remove grease, oil, or other contaminants from exterior surfaces using a clean wiping cloth (E120) (damp) with a detergent soap (E159.1) and water.
17. Dry cleaned area using compressed air.
18. Remove debris from inlet swirl tubes (from exterior side) using a vacuum cleaner.

***FOLLOW-ON-MAINTENANCE:***

As Required

END OF TASK

INITIAL SETUP

**Applicable Configurations:**

All

**Tools:**

Hoist  
EAPS Lifting Device (T188)

Guide Ropes (2)  
Mechanic's Tool Kit, NSN 5180-00-323-4692  
Torque Wrench, 30 to 150 Inch-Pounds

**Personnel Required:**

Medium Helicopter Repairer (3)  
Inspector

1. Remove quick release pins (12) from hook latch (13) and pin latch (14), bring handles to a fully open position and secure. Also, secure quick release pins (12) and lanyards away from mounting feet to prevent them from snagging during EAPS installation.

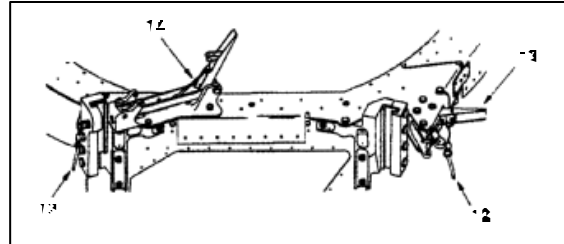

2. Install lower cross shaft seal (15) under cross shaft fairing with P-seal facing outboard. Position as far inboard as possible.

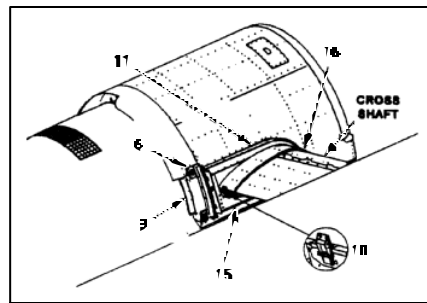

3. Check rails for cleanliness and smooth surface condition. Clean and/or repair surfaces as necessary.



Diffuser duct is made of fiberglass and can be easily damaged. Do not place weight on EAPS on diffuser duct. EAPS is made of lightweight metal and has thousands of plastic inlet swirl tubes. Surface contact with hard objects can damage plastic tubes and/or sheet metal surfaces.

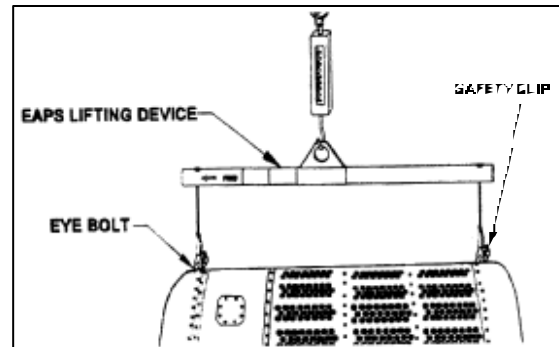

4. Place EAPS in horizontal position.
5. Attach EAPS Lifting Device (T188) to hoist and position above EAPS. Connect cables to eye bolts on EAPS secure with safety clips.



Lift EAPS carefully, avoid sudden starts and stops. It may require several persons to guide and steady EAPS during lifting, alignment and installation to prevent damage from occurring to equipment.

6. Lift EAPS until mounting feet are level and parallel with rails.



Keeps hands clear of rails.

7. Carefully move EAPS aft until both sets of mounting feet are on rails. If mounting feet do not align with rails, loosen inboard slide blocks, move the EAPS aft and tighten slide blocks. Once EAPS is on rails it must be able to be moved all the way forward and aft on rails.
8. Disconnect EAPS Lifting Device (T188) from EAPS.



Perform FOD check around engine inlet before moving EAPS to an aft position.

9. Slide EAPS aft until firmly seated against engine nacelle. P-seal on EAPS must contact engine D-ring at all points.

- 10. Push handle down to engage pin latch (14). Pin should move smoothly through rail bushing and into slide bushing. Use adjusting screw, located on fwd outboard slide block, to align pin with bushing if necessary.
- 11. Hold adjusting screw with hex head wrench and tighten lock nut.
- 12. Engage hook latch (13) with clevis block and close handle. A small amount of force should be required. Adjust hook if necessary.
- 13. Install quick release pins (12) in pin latch (14) and hook latch handles (13).

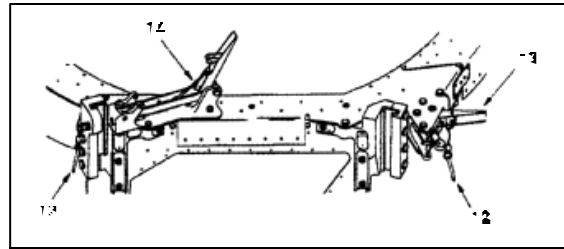

- 14. Place upper cross shaft seal over cross shaft fairing and attach to lower cross shaft seal with two shoulder bolts.
- 15. Position seal assemblies firmly against EAPS and connect latches (14). Install safety clips in latches. P-seals on upper and lower cross shaft seal must have contact with cross shaft fairing and EAPS at all points.
- 16. Install cross shaft link (9) in EAPS and engage Camloc. P-seals on cross link must make contact with mating surfaces at all points.

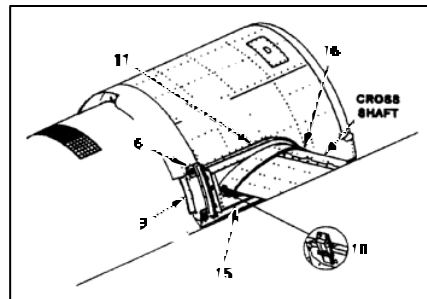

- 17. Install fwd bump stop (4) on inboard and outboard rail (5) and attach using two bolts (3), washers (2), and nuts (1). Torque nuts to **70 to 90 inch-pounds**.

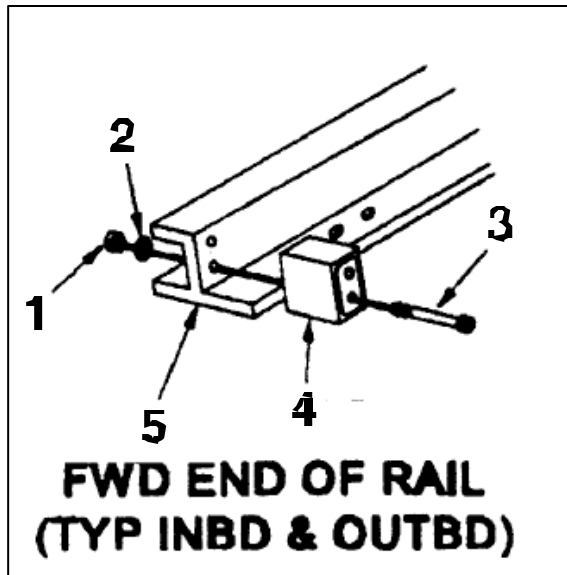

**16-110 INSTALL ENGINE AIR PARTICLE SEPERATOR (Continued)****16-110**

18. Disconnect dummy receptacle (8) from aircraft, connect electrical plug (7) from EAPS to aircraft. Connect dummy receptacle (8) to EAPS.
19. Connect 1/4 turn fastner (6) holding electrical cable clamp to aircraft.

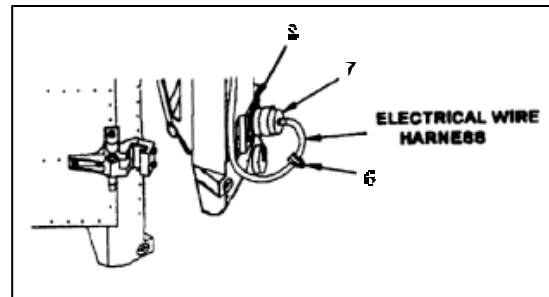
**INSPECT****FOLLOW-ON MAINTENANCE:**

As Required

END OF TASK

## INITIAL SETUP

**Applicable Configurations:**

All

**Tools:**

Electrical Repairer's Tool Kit, NSN 6625-00-556-4915

**Personnel Required:**Aircraft Electrician  
Inspector**Equipment Condition:**EAPS Removed (Task 16-109)  
Off Helicopter Task

1. Remove three bolts (1), five washers (2), and cable guard (3).
2. Remove washers (7), screws (8), and cable clamps (4).
3. Disconnect three connector plugs (6) and remove cable (5) from EAPS.
4. Install new cable (5) on EAPS and connect three connector plugs (4).
5. Install cable clamps (4) and cable guard (3).

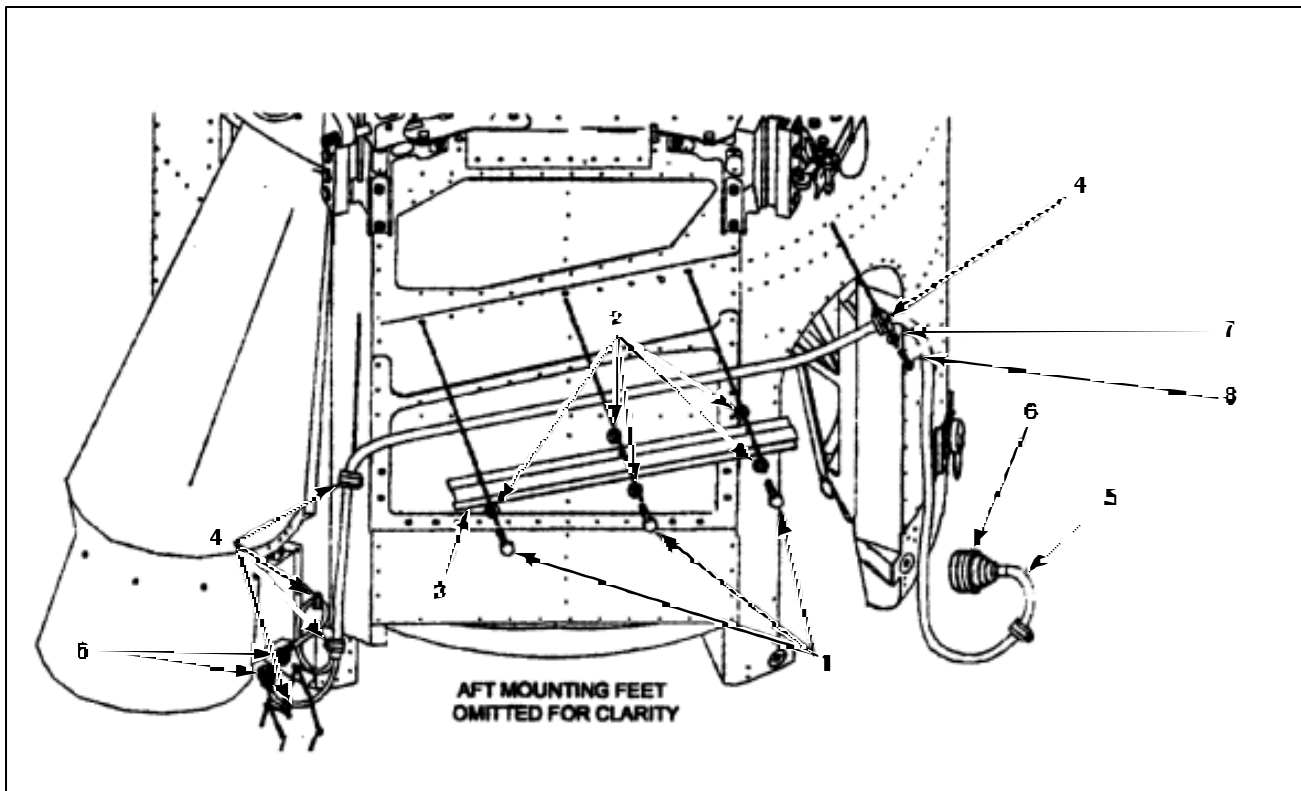
**INSPECT****FOLLOW-ON MAINTENANCE**

Install EAPS (Task 16-110).

END OF TASK

16-372

## INITIAL SETUP

**Applicable Configurations:**

All

**Tools:**

Mechanic's Tool Kit, NSN 5180-00-323-4692  
Torque Wrench, 30 to 200 Inch-Pounds

**Personnel Required:**

Medium Helicopter Repairer (2)  
Inspector

**Equipment Condition:**

Remove EAPS (Task 16-109)

1. Remove four screws (1) and washers (2) from each mounting foot (4).
2. Remove mounting foot (4) and shims (3), if installed. Keep shims (3) with corresponding mounting foot for reinstallation.
3. Install shims (3) (if applicable), mounting feet (4), screws (1), and washers (2). Torque fourteen **1/4 inch** screws to **90 to 100 inch-pounds**. Torque two **5/16 inch** screws (11) to **135-165 inch-pounds**.

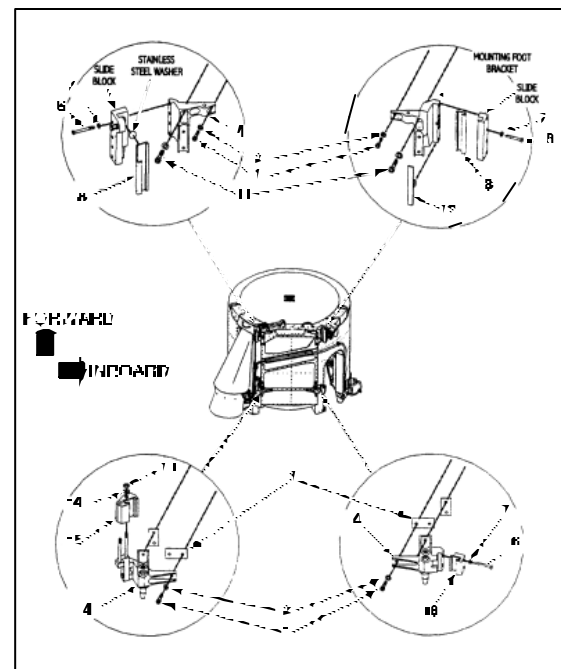
**INSPECT****FOLLOW-ON MAINTENANCE:**

Install EAPS (Task 16-110).

END OF TASK

## INITIAL SETUP

**Applicable Configurations:**

All

**Tools:**

Mechanic's Tool Kit, NSN 5180-00-323-4692

**Personnel Required:**

Medium Helicopter Repairer

**Equipment Condition:**

EAPS Removed (Task 16-109)

**FORWARD****OUTBOARD**

1. Remove four bolts (6) and washers (7) from forward outboard slide block (5).
2. Remove slide block (5), slide bearing (8) and stainless steel washer (9). Discard slide bearing (8).

**INBOARD**

3. Remove four bolts (6) and washers (7) from forward inboard slide block (10).
4. Remove slide block (10), shim (12) (if installed) and slide bearing (8). Discard slide bearing (8).

**AFT****OUTBOARD**

5. Remove two nuts (13) and washers (14) from aft outboard slide block (15).
6. Remove and discard slide block assembly (15).

**INBOARD**

7. Remove two bolts (6) and washers (7) from aft inboard slide block (16).
8. Remove and discard slide block assembly (16).

**FOLLOW-ON MAINTENANCE:**

None

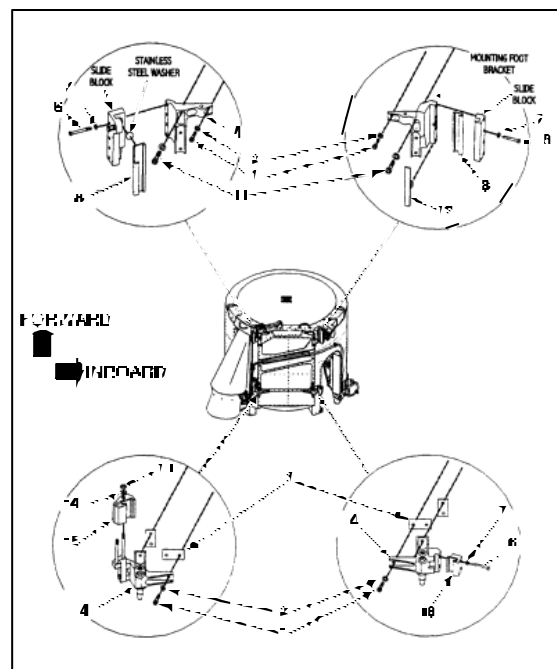

END OF TASK

16-374



**16-114 INSTALLATION OF EAPS SLIDE BEARING/BLOCKS****16-114****INITIAL SETUP****Applicable Configurations:**

All

**Tools:**

General Mechanic's Tool Kit, NSN 5180-00-323-4692

**Personnel Required:**Medium Helicopter Repairer (2)  
Inspector**Equipment Condition:**

EAPS Removed (Task 16-109)

**FORWARD****OUTBOARD**

1. Install stainless steel washer (9) and new slide bearing (8) in slide block (5).
2. Install slide block (8) and attach with four bolts (6) and washers (7).

**INBOARD**

3. Install new slide block (15) in slide block (10).
4. Install shim (12) (if applicable) and slide block (10) and attach with four bolts (6) and washers (7).

**AFT****OUTBOARD**

5. Install new slide block (15) and attach with two nuts (13) and washers (14).

**INBOARD**

6. Install new slide block (16) and attach with two bolts (6) and washers (7).

**INSPECT****FOLLOW-ON MAINTENANCE:**

Install EAPS (Task 16-110).

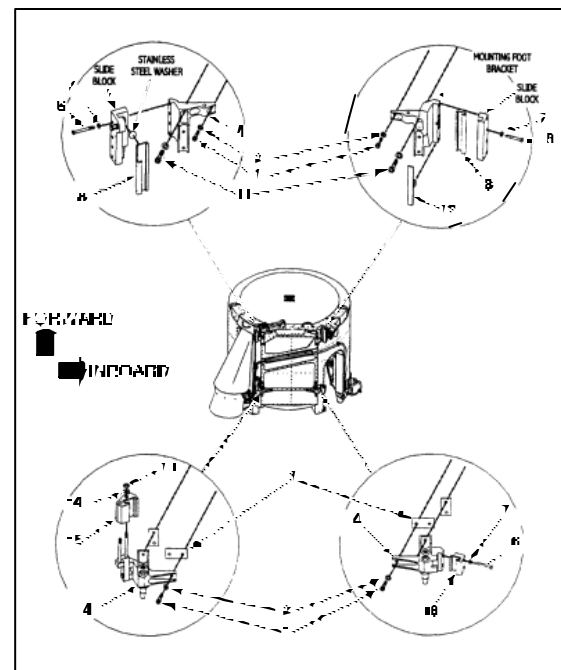

END OF TASK

## INITIAL SETUP

**Applicable Configurations:**

All

**Tools:**

Mechanic's Tool Kit, NSN 5180-00-323-4692

**Personnel Required:**Medium Helicopter Repairer (2)  
Inspector**Equipment Condition:**

Remove EAPS (Task 16-109)

**NOTE**

Mounting ring for RH EAPS requires thirty-two screws and washers for installation, whereas LH EAPS mounting ring requires only thirty screws and washers.

1. Remove thirty or thirty-two screws (1) and washers (2) from FOD screen (3).
2. Remove FOD screen (3) and mounting ring (4) as an assembly from EAPS.
3. Remove debris from FOD screens using a vacuum cleaner.
4. Install FOD screen/mounting ring assembly in EAPS, and secure with thirty or thirty-two screws (1) and washers (2).

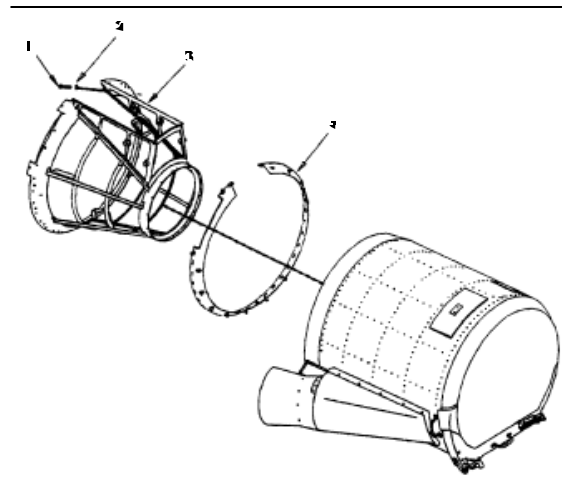
**INSPECT****FOLLOW-ON MAINTENANCE:**

Install EAPS (Task 16-110).

END OF TASK

16-376

**16-116 REPLACE EAPS PIN LATCH****16-116****INITIAL SETUP****Applicable Configurations:**

All

**Tools:**

Mechanic's Tool Kit, NSN 5180-00-323-4692

**Personnel Required:**Medium Helicopter Repairer  
Inspector

1. Remove two nuts (5), two bolts (6), three washers (7), and pin latch (8) from pin latch bracket (9).
2. Install new pin latch (8) (handle must be in open position), bolts (6), washers (7), and nuts (5).
3. Close pin latch handle (10).

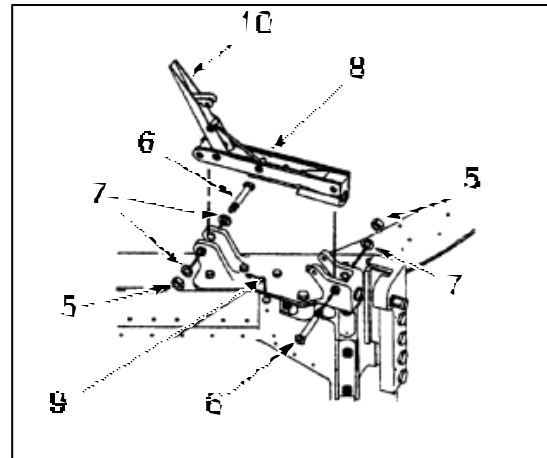
**INSPECT****FOLLOW-ON MAINTENANCE:**

None

END OF TASK

## INITIAL SETUP

**Applicable Configurations:**

All

**Tools:**

Mechanic's Tool Kit, NSN 5180-00-323-4692

**Personnel Required:**Medium Helicopter Repairer  
Inspector**Equipment Condition:**

Remove EAPS (Task 16-109)

**REMOVE**

1. Remove inboard forward slide block assembly.
2. Remove nut (11), bolt (12), and hook latch (14) from hook latch bracket (13).

**INSTALL**

3. Before installing new hook latch, adjust hook length to match old hook.
4. Install new hook latch (14), bolt (12), and nut (11).
5. Install inboard forward slide block assembly.

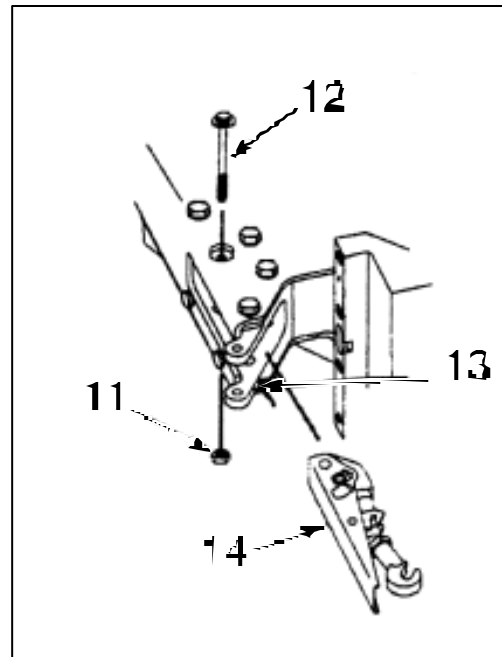
**INSPECT****FOLLOW-ON MAINTENANCE:**

Install EAPS (Task 16-110).

END OF TASK

16-378

**INITIAL SETUP****Applicable Configurations:**

All

**Tools:**

Mechanic's Tool Kit, NSN 5180-00-323-4692

**Materials:**

Threaded Adhesive Primer (E295.1)

**Personnel Required:**Medium Helicopter Repairer  
Inspector**Equipment Condition:**Battery Disconnected (Task 1-39)  
Electrical Power Off**REMOVE**

1. Remove eight screws (2), eight washers (3), and diffuser duct (1).

**INSTALL**

2. Apply threaded adhesive primer (E295.1) to eight screws (2). Allow primer to dry.
3. Install diffuser duct on scavenge blower (4).



Do not over-tighten screws attaching diffuser duct. Diffuser duct is made of fiberglass and can be easily damaged. Make sure screws do not extend through scavenge blower housing and cause interference with fan blades.

3. Install eight screws (2) with washers (3). Tighten until snug.

**INSPECT****FOLLOW-ON MAINTENANCE:**

As Required

END OF TASK

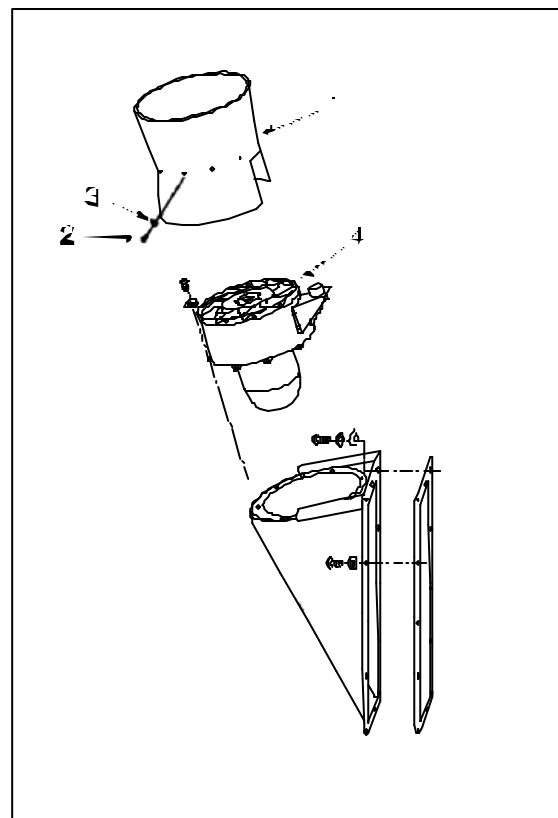

## INITIAL SETUP

**Applicable Configurations:**

All

**Tools:**

Mechanic's Tool Kit, NSN 5180-00-323-4692

**Personnel Required:**

Medium Helicopter Repairer

**Equipment Condition:**

Remove EAPS (Task 16-109)  
Diffuser Duct Removed (Task 16-118)  
Battery Disconnected (Task 1-39)  
Electrical Power Off

**REMOVE**

1. Disconnect electrical plug from scavenge blower receptacle (5).
2. Remove eight screws (6), eight washers (7), and scavenge blower (4) from scavenge duct (8).

**INSTALL**

3. Install scavenge blower (4), eight screws (6), and eight washers (7) in scavenge duct (8).
4. Connect electrical plug to receptacle (5) on scavenge blower (4).

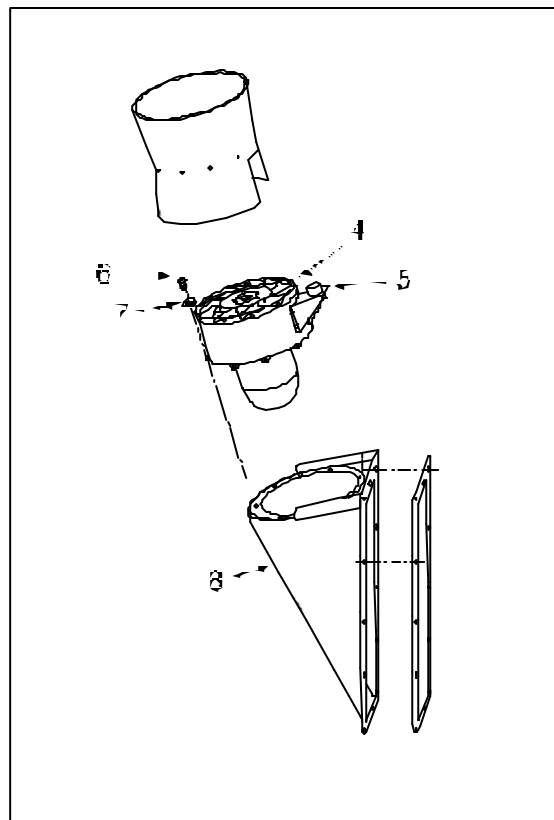
**INSPECT****FOLLOW-ON MAINTENANCE:**

Replace diffuser duct (Task 16-118).  
Install EAPS (Task 16-110).

END OF TASK

16-380

**16-120 REPLACE EAPS SCAVENGE BLOWER IMPELLAR****16-120****INITIAL SETUP****Applicable Configurations:**

All

**Tools:**

Impellar Extractor Tool (T189)  
 Mechanic's Tool Kit, NSN 5180-00-323-4692  
 Torque Wrench, 0 to 50 Inch-Pounds

**Personnel Required:**

Medium Helicopter Repairer  
 Inspector

**Equipment Condition:**

Remove EAPS (Task 16-109)  
 Diffuser Duct Removed (Task 16-118)  
 Remove Scavenge Blower Assembly (Task 16-119)  
 Battery Disconnected (Task 1-39)  
 Electrical Power Off

1. Remove nut (9) and tab washer (10) from blower shaft. Bend tab so it is flat and horizontal with washer.

**NOTE**

If metal where tab attaches to washer shows sign of cracking from previous maintenance, replace washer.

2. Place impeller extractor tool (T189) over shaft and line up mounting holes.
3. Screw extractor mounting screws (11) into two holes on impeller (12).
4. Turn center bolt (13) in until impeller comes loose from shaft (14).
5. Clean woodruff key (15) and shaft and place new impeller on shaft.
6. Install tab washer (10) and nut (9). Tighten nut to **20 to 25 inch-pounds** using torque wrench. Tab on washer must align with flat on nut.
7. Bend tab on washer (10) up against flat on nut.

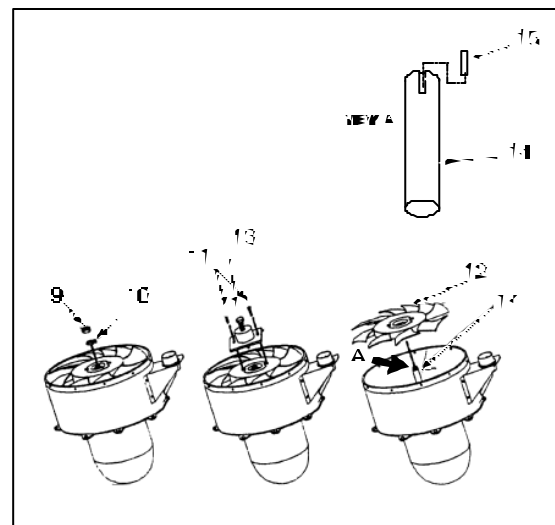
**INSPECT****FOLLOW-ON MAINTENANCE:**

Install scavenge blower assembly (Task 16-119).  
 Install diffuser duct (Task 16-118).  
 Install EAPS (Task 16-110).

END OF TASK

## INITIAL SETUP

**Applicable Configurations:**

All

**Tools:**

Mechanic's Tool Kit, NSN 5180-00-323-4692

**Personnel Required:**Medium Helicopter Repairer  
Inspector**Equipment Condition:**Remove EAPS (Task 16-109)  
Remove Diffuser Duct (Task 16-118)  
Remove Scavenge Blower Assembly (Task 16-120)**REMOVE**

1. Remove two cap screws (16), flat washers (15) and saddle washers (17) from open end of scavenge duct (8) where blower mounts.
2. Remove eleven cap screws (19), eleven flat washers (20), scavenge duct (8) and gasket from EAPS.

**INSTALL**

3. Install gasket (18) and scavenge duct (8) on EAPS and attach with eleven cap screws (19) and flat washers (20).
4. Install two saddle washers (17), flat washers (15), and cap screws (16) in open end of scavenge duct (8).

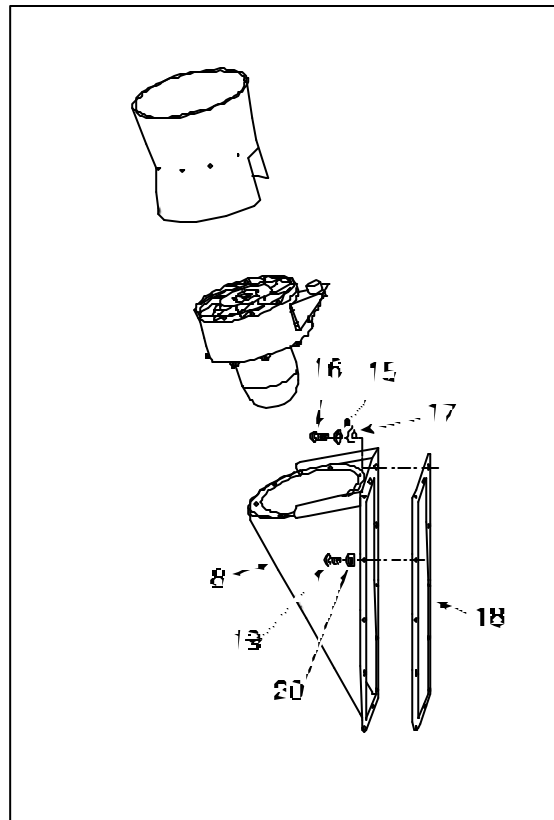
**INSPECT****FOLLOW-ON MAINTENANCE:**Install scavenge blower assembly (Task 16-120).  
Install diffuser duct (Task 16-119).  
Install EAPS (Task 16-110).

END OF TASK

16-382



**16-122 REPLACE EAPS DIFFERENTIAL PRESSURE SWITCH****16-122****INITIAL SETUP****Applicable Configurations:**

All

**Tools:**

Electrician's Tool Kit, NSN 6625-00-556-4915

**Personnel Required:**Aircraft Electrician  
Inspector**Equipment Condition:**

Remove Diffuser Duct (Task 16-118)

**REMOVE**

1. Disconnect electrical plug from pressure switch housing receptacle (1).
2. Mark tubing (3) (HI and LOW) and disconnect from pressure switch (2).
3. Remove six screws (4) and flat washers (5) attaching pressure switch housing (1) to EAPS.
4. Disconnect electrical plug from pressure switch receptacle (6).
5. Remove four screws (7), four washers (8), and pressure switch from housing (1).
6. Remove two right-angle fittings (9) from pressure switch (2). Remove and discard O-rings (10) from fittings.

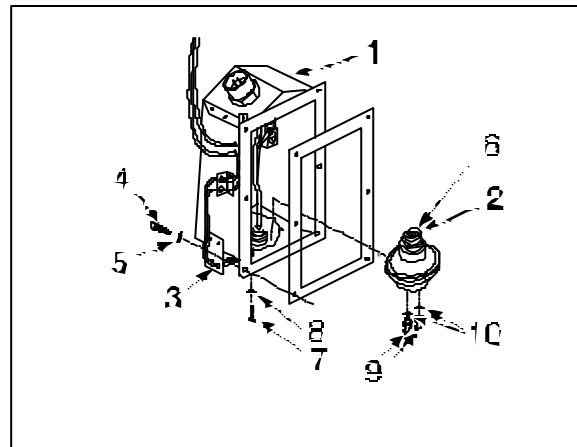
**INSTALL**

7. Install new O-rings (10) on right-angle fittings (9) and install in new pressure switch.
8. Install pressure switch (2) in housing and secure with four screws (7) and washers (8).
9. Connect electrical plug to pressure switch receptacle (6).
10. Attach pressure switch housing (1) to EAPS with six screws (4) and flat washers (5).
11. Connect tubing (3) to right-angle fittings (9) on pressure switch (2).
12. Connect electrical plug to receptacle on pressure switch housing (1).

**INSPECT****FOLLOW-ON MAINTENANCE:**

Install diffuser duct (Task 16-118).

END OF TASK

## INITIAL SETUP

**Applicable Configurations:**

All

**Tools:**

Mechanic's Tool Kit, NSN 5180-00-323-4692  
Torque Wrench, 1 to 100 Inch-Pounds

**Personnel Required:**

Medium Helicopter Repairer  
Inspector

**Equipment Condition:**

Battery Disconnected (Task 1-39)  
Electrical Power Off

**REMOVE**

1. Remove two screws (11), access cover (13), and gasket (12) from bypass door (14).
2. Remove nut (15), bolt (16), and two washers (17) from rod end of actuator (18).
3. Remove bypass door (14) from EAPS.
4. Remove FOD screen (Task 16-115).
5. Remove six screws (19), six washers (20), shims (22) (if installed), and front FOD screen (23). Keep shims (23) with corresponding gusset (21) for reinstallation.
6. From inside EAPS remove bolt (25) from actuator (26).
7. Separate sheet metal cover (24) from actuator (26).
8. Disconnect electrical plug (27) from receptacle on actuator (26).
9. Remove actuator from outside of EAPS.

**INSTALL****NOTE**

Before installing new actuator (26), adjust rod end length to match old actuator (26).

10. Install new actuator (26) in EAPS.
11. Connect electrical plug (27) to receptacle on actuator (26).
12. Slide sheet metal cover (26) and align holes for mounting bolt (25).
13. Install bolt (25) and torque to **60 to 70 inch-pounds**.
14. Make sure actuator rod (18) is fully retracted.
15. Install bypass door (14) and check alignment of mounting bolt holes. Adjust rod end length if holes are misaligned.
16. Install bolt (16), two washers (17), and nut (15) in rod end of actuator (18). Torque nut (15) to **60 to 70 inch-pounds**.
17. Install gasket (12), access cover (13), and two screws (11) in bypass door.

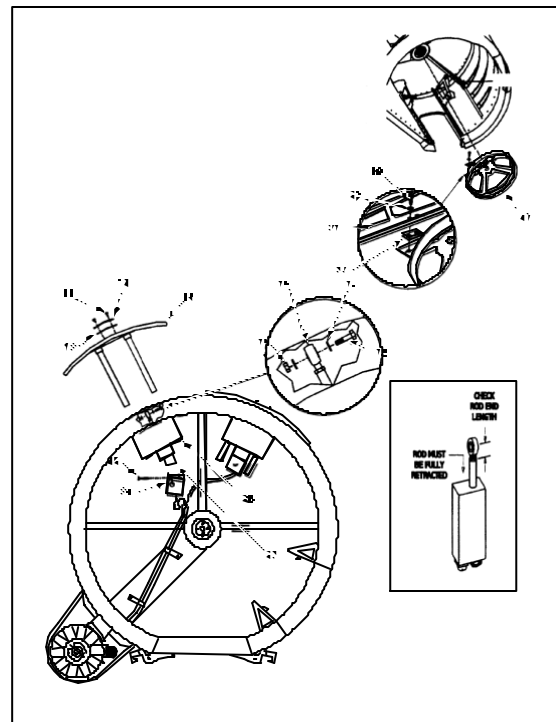

18. Install front FOD screen (23) and attach with six screws, six washers (19), six washers (20), and shims (22) (if applicable).
19. Install FOD screen (Task 16-115).

**INSPECT****FOLLOW-ON MAINTENANCE:**

None

END OF TASK

INITIAL SETUP

**Applicable Configurations:**

All

**Tools:**

Inspector's Tool Kit, NSN 5180-00-323-5114  
Blade Erosion Gage (T190)

**Personnel Required:**

Inspector

1. Check blades of scavenge blower impeller for wear using blade erosion gage (T190).
  - a. Check clearance at leading edge of each blade using larger end of gage. The gage shall not pass between blower housing and leading edge of blade.
  - b. Check clearance at center of each blade using smaller end of gage. The gage shall not pass between blower housing and center point of blade.
2. Check impeller blades and blower housing for any unusual wear patterns, crack, or other damage.

**NOTE**

Perform the inspection below after **50 hours** of operation under normal conditions and more frequently under high dust conditions.

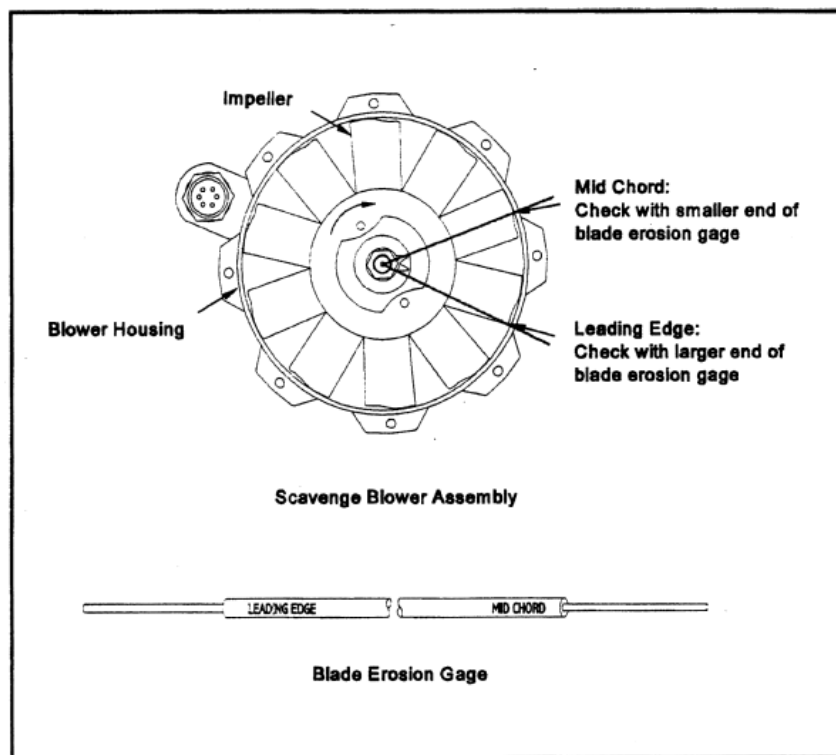

END OF TASK

## INITIAL SETUP

**Applicable Configurations:**

All

**Personnel Required:**

Aircraft Repairer

**NOTE**

The EAPS fault isolation chart identify the most probable malfunctions of EAPS.

TROUBLE	PROBABLE CAUSE	REMEDY
Excessive accumulation of contaminants (sand/dust) inside of EAPS or at intake	<ul style="list-style-type: none"> <li>a. Seals improperly seated</li> <li>b. Seals damaged, cracked, or torn</li> <li>c. Bypass doors were opened during operation</li> </ul>	<ul style="list-style-type: none"> <li>a. Check and adjust seating of seals</li> <li>b. Replace seals</li> <li>c. Check item 6 in this guide</li> </ul>
Scavenge blower does not operate	<ul style="list-style-type: none"> <li>a. No power to blower assembly</li> <li>b. Defective blower assembly</li> <li>c. Defective electrical wire harness</li> </ul>	<ul style="list-style-type: none"> <li>a. Check aircraft electrical system</li> <li>b. Replace blower assembly</li> <li>c. Replace electrical wire harness</li> </ul>
Scavenge blower has excessive vibration	<ul style="list-style-type: none"> <li>a. Impeller blade has excessive or uneven wear</li> <li>b. Blower assembly loose or not properly installed</li> <li>c. Defective blower assembly</li> </ul>	<ul style="list-style-type: none"> <li>a. Replace impeller</li> <li>b. Check blower assembly installation</li> <li>c. Replace blower assembly</li> </ul>
Both bypass doors will not open	<ul style="list-style-type: none"> <li>a. No power to door actuators</li> <li>b. Defective electrical wire harness</li> </ul>	<ul style="list-style-type: none"> <li>a. Check aircraft electrical system</li> <li>b. Replace electrical wire harness</li> </ul>
Either bypass door does not open (one door opens/ one does not)	<ul style="list-style-type: none"> <li>a. Bypass door actuator defective</li> </ul>	<ul style="list-style-type: none"> <li>a. Replace bypass door actuator</li> </ul>
EAPS warning light comes on	<ul style="list-style-type: none"> <li>a. Inlet tubes blocked or damaged</li> <li>b. Differential pressure switch is defective</li> </ul>	<ul style="list-style-type: none"> <li>a. Clean or replace damaged tubes</li> <li>b. Replace differential pressure switch</li> </ul>

**FOLLOW-ON MAINTENANCE:**

As Required

END OF TASK

By Order of the Secretary of the Army:

Official:

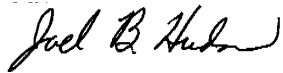

**JOEL B. HUDSON**  
Administrative Assistant to the  
Secretary of the Army  
0220714

**ERIC K. SHINSEKI**  
General, United States Army  
Chief of Staff

DISTRIBUTION:

To be distributed in accordance with Initial Distribution Number (IDN) 311199, requirements for TM 55-1520-240-23-10.

## ***These are the instructions for sending an electronic 2028***

The following format must be used if submitting an electronic 2028. The subject line must be exactly the same and all fields must be included; however only the following fields are mandatory: 1, 3, 4, 5, 6, 7, 8, 9, 10, 13, 15, 16, 17, and 27.

From: "Whomever" <whomever@wherever.army.mil>

To: 2028@redstone.army.mil

Subject: DA Form 2028

1. **From:** Joe Smith
2. **Unit:** home
3. **Address:** 4300 Park
4. **City:** Hometown
5. **St:** MO
6. **Zip:** 77777
7. **Date Sent:** 19-OCT-93
8. **Pub no:** 55-2840-229-23
9. **Pub Title:** TM
10. **Publication Date:** 04-JUL-85
11. **Change Number:** 7
12. **Submitter Rank:** MSG
13. **Submitter FName:** Joe
14. **Submitter MName:** T
15. **Submitter LName:** Smith
16. **Submitter Phone:** 123-123-1234
17. **Problem:** 1
18. **Page:** 2
19. **Paragraph:** 3
20. **Line:** 4
21. **NSN:** 5
22. **Reference:** 6
23. **Figure:** 7
24. **Table:** 8
25. **Item:** 9
26. **Total:** 123
27. **Text:**

This is the text for the problem below line 27.

<b>RECOMMENDED CHANGES TO PUBLICATIONS AND BLANK FORMS</b>  <small>For use of this form, see AR 25-30; the proponent agency is ODISC4.</small>	Use Part II ( <i>reverse</i> ) for Repair Parts and Special Tool Lists (RPSTL) and Supply Catalogs/Supply Manuals (SC/SM)	DATE  <h1 style="text-align: center;">8/30/02</h1>
--	---	--

TO: ( <i>Forward to proponent of publication or form</i> )( <i>Include ZIP Code</i> ) Commander, U.S. Army Aviation and Missile Command ATTN: AMSAM-MMC-MA-NP Redstone Arsenal, 35898	FROM: ( <i>Activity and location</i> )( <i>Include ZIP Code</i> ) MSG, Jane Q. Doe 1234 Any Street Nowhere Town, AL 34565
--	--

**PART 1 - ALL PUBLICATIONS (EXCEPT RPSTL AND SC/SM) AND BLANK FORMS**

PUBLICATION/FORM NUMBER <h2 style="text-align: center;">TM 9-1005-433-24</h2>	DATE <h2 style="text-align: center;">16 Sep 2002</h2>	TITLE Organizational, Direct Support, And General Support Maintenance Manual for Machine Gun, .50 Caliber M3P and M3P Machine Gun Electrical Test Set Used On Avenger Air Defense Weapon System
--	--	---

ITEM NO.	PAGE NO.	PARA-GRAPH	LINE NO. *	FIGURE NO.	TABLE NO.	RECOMMENDED CHANGES AND REASON
1	WP0005 PG 3		2			Test or Corrective Action column should identify a different WP number.  <div style="text-align: center; border: 2px solid black; padding: 50px;"> <h1 style="margin: 0;">SAMPLE</h1> </div>

\* Reference to line numbers within the paragraph or subparagraph.

TYPED NAME, GRADE OR TITLE  <h2 style="text-align: center;">MSG, Jane Q. Doe, SFC</h2>	TELEPHONE EXCHANGE/ AUTOVON, PLUS EXTENSION  <h2 style="text-align: center;">788-1234</h2>	SIGNATURE
--	---	-----------

<b>TO:</b> (Forward direct to addressee listed in publication) Commander, U.S. Army Aviation and Missile Command ATTN: AMSAM-MMC-MA-NP Redstone Arsenal, 35898	<b>FROM:</b> (Activity and location) (Include ZIP Code) MSG, Jane Q. Doe 1234 Any Street Nowhere Town, AL 34565	<b>DATE</b> 8/30/02
---	--	------------------------

**PART II - REPAIR PARTS AND SPECIAL TOOL LISTS AND SUPPLY CATALOGS/SUPPLY MANUALS**

PUBLICATION NUMBER			DATE	TITLE				
PAGE NO.	COLM NO.	LINE NO.	NATIONAL STOCK NUMBER	REFERENCE NO.	FIGURE NO.	ITEM NO.	TOTAL NO. OF MAJOR ITEMS SUPPORTED	RECOMMENDED ACTION
<b>SAMPLE</b>								

**PART III - REMARKS** (Any general remarks or recommendations, or suggestions for improvement of publications and blank forms. Additional blank sheets may be used if more space is needed.)

TYPED NAME, GRADE OR TITLE <b>MSG, Jane Q. Doe, SFC</b>	TELEPHONE EXCHANGE/AUTOVON, PLUS EXTENSION <b>788-1234</b>	SIGNATURE
--	---	-----------



<b>RECOMMENDED CHANGES TO PUBLICATIONS AND BLANK FORMS</b>  For use of this form, see AR 25-30; the proponent agency is ODISC4.	Use Part II (reverse) for Repair Parts and Special Tool Lists (RPSTL) and Supply Catalogs/Supply Manuals (SC/SM)	DATE
---	--	------

TO: (Forward to proponent of publication or form)(Include ZIP Code)	FROM: (Activity and location)(Include ZIP Code)
---	---

**PART 1 - ALL PUBLICATIONS (EXCEPT RPSTL AND SC/SM) AND BLANK FORMS**

PUBLICATION/FORM NUMBER <b>TM 9-1005-433-24</b>	DATE <b>16 Sep 2002</b>	TITLE Organizational, Direct Support, And General Support Maintenance Manual for Machine Gun, .50 Caliber M3P and M3P Machine Gun Electrical Test Set Used On Avenger Air Defense Weapon System
--	----------------------------	---

ITEM NO.	PAGE NO.	PARA-GRAPH	LINE NO. *	FIGURE NO.	TABLE NO.	RECOMMENDED CHANGES AND REASON

\* Reference to line numbers within the paragraph or subparagraph.

TYPED NAME, GRADE OR TITLE	TELEPHONE EXCHANGE/ AUTOVON, PLUS EXTENSION	SIGNATURE
----------------------------	--	-----------

<b>TO:</b> (Forward direct to addressee listed in publication)	<b>FROM:</b> (Activity and location) (Include ZIP Code)	<b>DATE</b>
--	---	-------------

**PART II - REPAIR PARTS AND SPECIAL TOOL LISTS AND SUPPLY CATALOGS/SUPPLY MANUALS**

<b>PUBLICATION NUMBER</b>	<b>DATE</b>	<b>TITLE</b>
---------------------------	-------------	--------------

PAGE NO.	COLM NO.	LINE NO.	NATIONAL STOCK NUMBER	REFERENCE NO.	FIGURE NO.	ITEM NO.	TOTAL NO. OF MAJOR ITEMS SUPPORTED	RECOMMENDED ACTION

**PART III - REMARKS** (Any general remarks or recommendations, or suggestions for improvement of publications and blank forms. Additional blank sheets may be used if more space is needed.)

TYPED NAME, GRADE OR TITLE	TELEPHONE EXCHANGE/AUTOVON, PLUS EXTENSION	SIGNATURE
----------------------------	--	-----------

## The Metric System and Equivalents

### Linear Measure

1 centimeter = 10 millimeters = .39 inch  
 1 decimeter = 10 centimeters = 3.94 inches  
 1 meter = 10 decimeters = 39.37 inches  
 1 dekameter = 10 meters = 32.8 feet  
 1 hectometer = 10 dekameters = 328.08 feet  
 1 kilometer = 10 hectometers = 3,280.8 feet

### Weights

1 centigram = 10 milligrams = .15 grain  
 1 decigram = 10 centigrams = 1.54 grains  
 1 gram = 10 decigrams = .035 ounce  
 1 decagram = 10 grams = .35 ounce  
 1 hectogram = 10 decagrams = 3.52 ounces  
 1 kilogram = 10 hectograms = 2.2 pounds  
 1 quintal = 100 kilograms = 220.46 pounds  
 1 metric ton = 10 quintals = 1.1 short tons

### Liquid Measure

1 centiliter = 10 milliliters = .34 fl. ounce  
 1 deciliter = 10 centiliters = 3.38 fl. ounces  
 1 liter = 10 deciliters = 33.81 fl. ounces  
 1 dekaliter = 10 liters = 2.64 gallons  
 1 hectoliter = 10 dekaliters = 26.42 gallons  
 1 kiloliter = 10 hectoliters = 264.18 gallons

### Square Measure

1 sq. centimeter = 100 sq. millimeters = .155 sq. inch  
 1 sq. decimeter = 100 sq. centimeters = 15.5 sq. inches  
 1 sq. meter (centare) = 100 sq. decimeters = 10.76 sq. feet  
 1 sq. dekameter (are) = 100 sq. meters = 1,076.4 sq. feet  
 1 sq. hectometer (hectare) = 100 sq. dekameters = 2.47 acres  
 1 sq. kilometer = 100 sq. hectometers = .386 sq. mile

### Cubic Measure

1 cu. centimeter = 1000 cu. millimeters = .06 cu. inch  
 1 cu. decimeter = 1000 cu. centimeters = 61.02 cu. inches  
 1 cu. meter = 1000 cu. decimeters = 35.31 cu. feet

## Approximate Conversion Factors

<i>To change</i>	<i>To</i>	<i>Multiply by</i>	<i>To change</i>	<i>To</i>	<i>Multiply by</i>
inches	centimeters	2.540	ounce-inches	Newton-meters	.007062
feet	meters	.305	centimeters	inches	.394
yards	meters	.914	meters	feet	3.280
miles	kilometers	1.609	meters	yards	1.094
square inches	square centimeters	6.451	kilometers	miles	.621
square feet	square meters	.093	square centimeters	square inches	.155
square yards	square meters	.836	square meters	square feet	10.764
square miles	square kilometers	2.590	square meters	square yards	1.196
acres	square hectometers	.405	square kilometers	square miles	.386
cubic feet	cubic meters	.028	square hectometers	acres	2.471
cubic yards	cubic meters	.765	cubic meters	cubic feet	35.315
fluid ounces	milliliters	29.573	cubic meters	cubic yards	1.308
pints	liters	.473	milliliters	fluid ounces	.034
quarts	liters	.946	liters	pints	2.113
gallons	liters	3.785	liters	quarts	1.057
ounces	grams	28.349	liters	gallons	.264
pounds	kilograms	.454	grams	ounces	.035
short tons	metric tons	.907	kilograms	pounds	2.205
pound-feet	Newton-meters	1.356	metric tons	short tons	1.102
pound-inches	Newton-meters	.11296			

### Temperature (Exact)

<b>F</b>	Fahrenheit temperature	5/9 (after subtracting 32)	Celsius temperature	<b>C</b>
----------	------------------------	----------------------------	---------------------	----------

